

ASSEMBLY INSTRUCTIONS

Twin Daybed w open shelves and 2 drawers

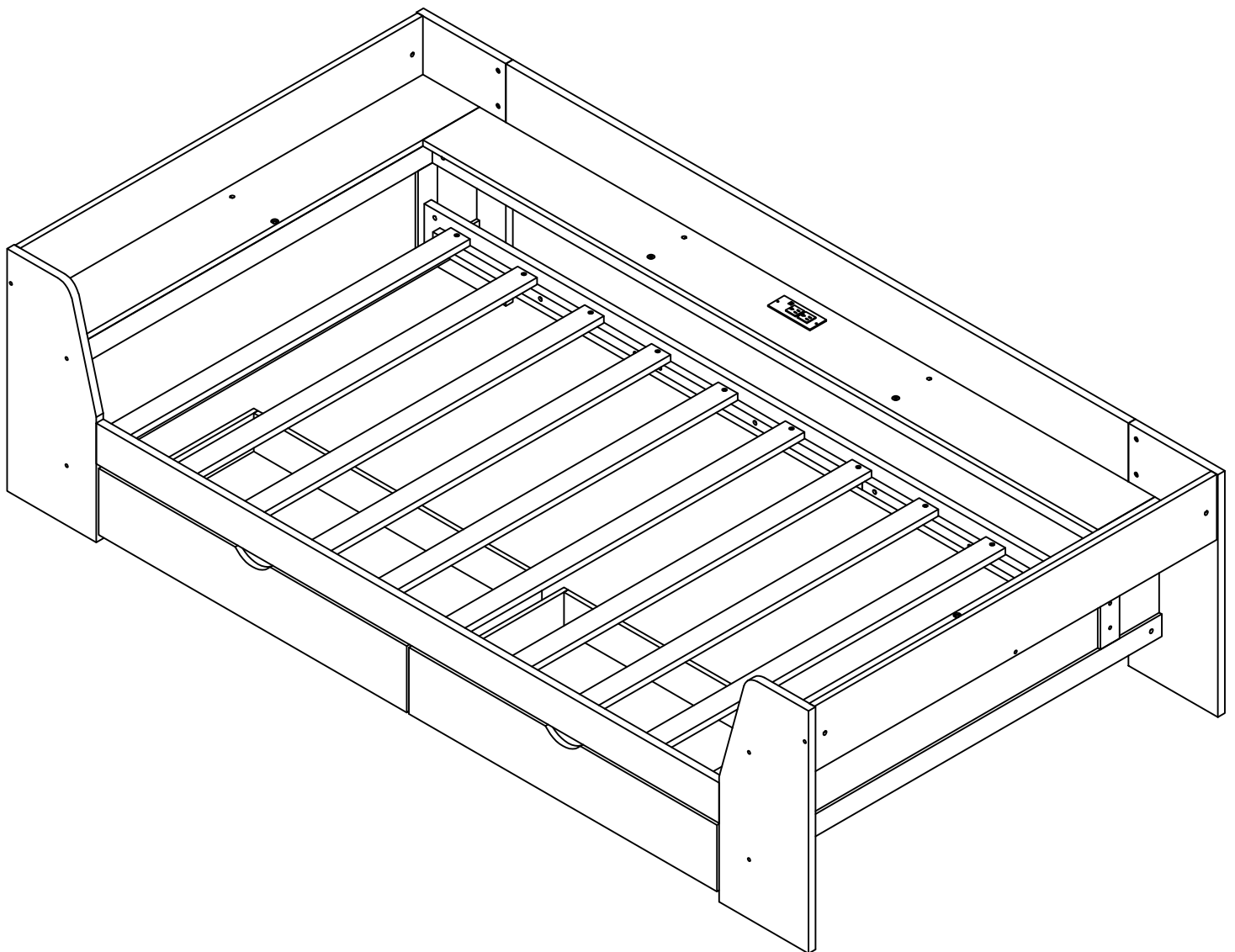





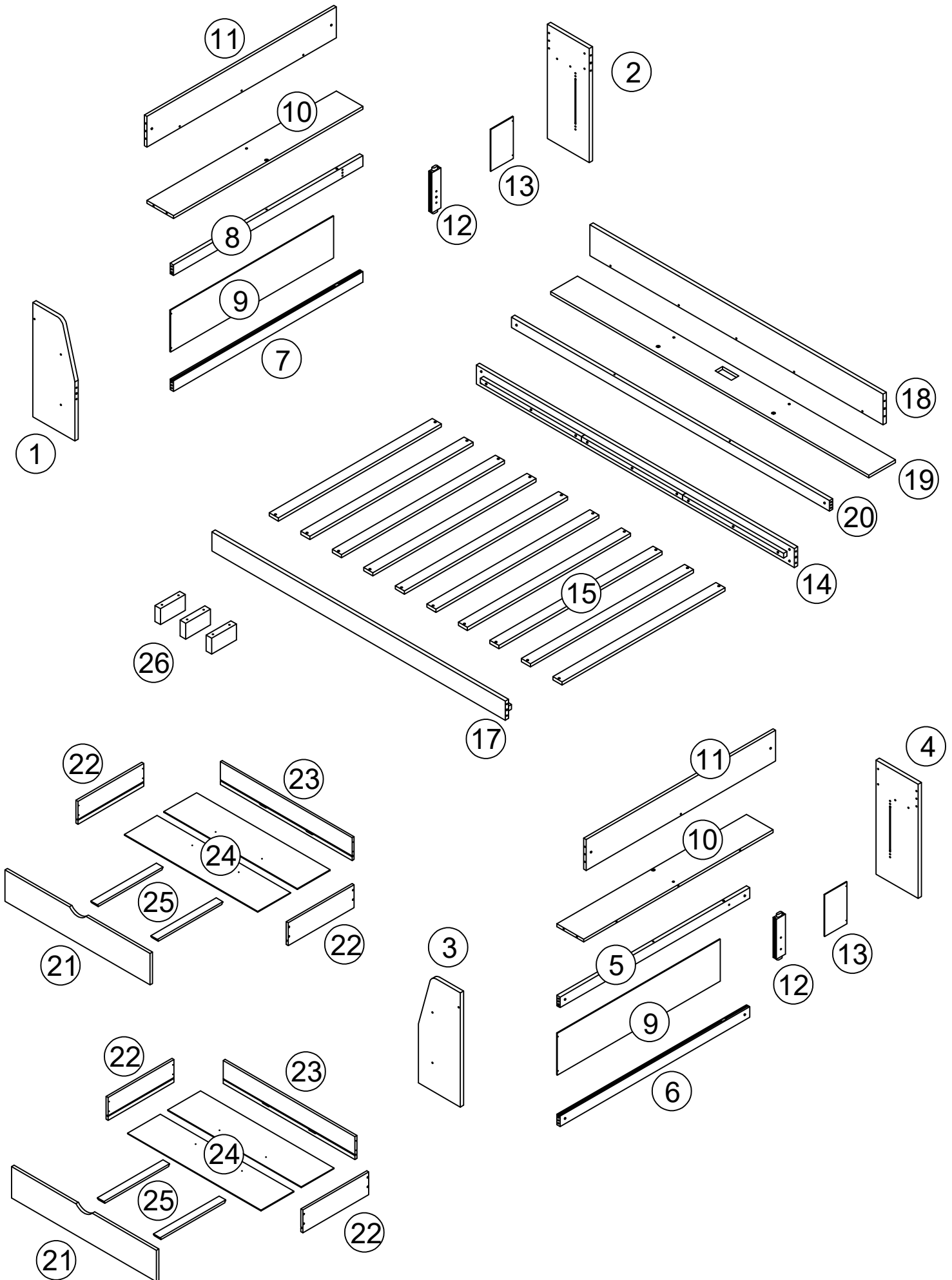



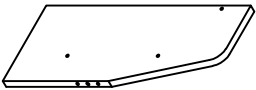
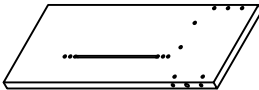

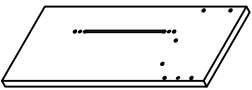
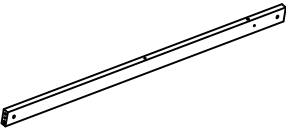
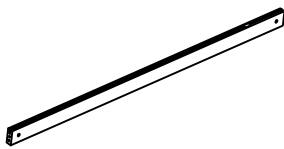

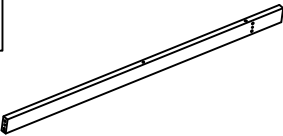
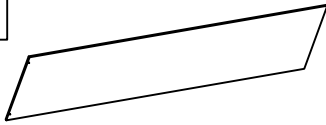
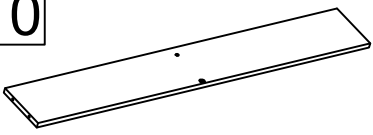
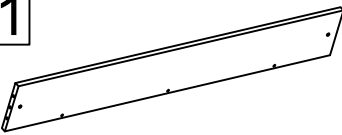
WF306024

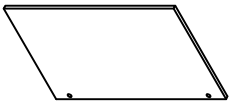

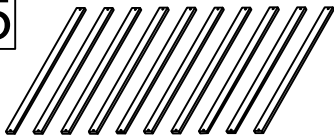
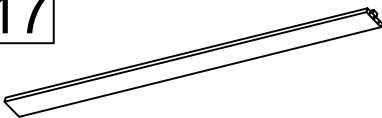

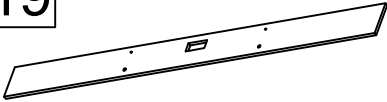
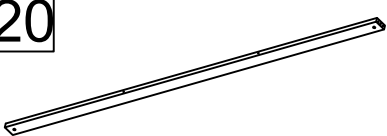
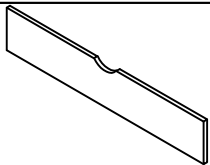
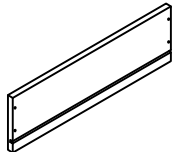
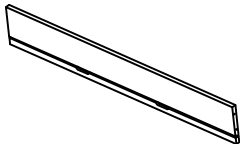
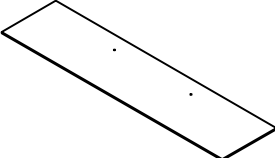
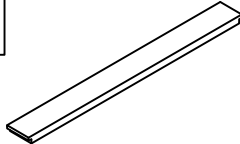

Detail View

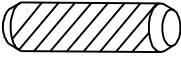
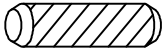

Part Lists : WF306024

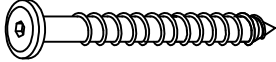
1		2		3	
	Front leg - 1pc		Back leg - 1pc		Front leg - 1pc
4		5		6	
	Back leg - 1pc		Upper beam (above) - 1pc		Lower beam (below) - 1pc
7		8		9	
	Lower beam (below) - 1pc		Upper beam (above) - 1pc		Large panel - 2pcs
10		11		12	
	Laying panels - 2pcs		Standing Panels - 2pcs		Base - 2pcs
13		14		15	
	Small panel - 2pcs		Back shoulder - 1pc		Slats - 10pcs
17		18		19	
	Front shoulder - 1pc		Long standing panels - 1pc		Laying panels - 2pcs
20		21		22	
	Long beams - 1pc		Drawer side - 2pcs		Drawstring hip - 4pcs
23		24		25	
	Back drawer - 2pcs		Drawer bottom plate - 4pcs		Bottom support - 4pcs
26					
	Drawer blocker - 3pcs				

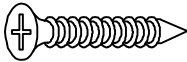
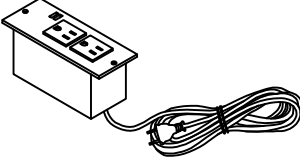
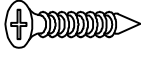
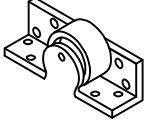
Hardware Lists : WF306024

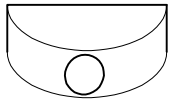
<p>A</p>  <p>Ø10*30mm</p> <p>Wood dowel (6pcs)</p>	<p>B</p>  <p>Ø8*30mm</p> <p>Wood dowel (43pcs)</p>	<p>C</p>  <p>Ø1/4"*65mm</p> <p>Hex-Head bolt (30pcs)</p>
<p>D</p>  <p>Ø6*50mm</p> <p>Hex-Head screw (4pcs)</p>	<p>E</p>  <p>Ø1/4"*9.5*12mm</p> <p>Horizontal-Hole bolt (30pcs)</p>	<p>F</p>  <p>K4mm</p> <p>Allen key (1pc)</p>
<p>G</p>  <p>#4*30mm</p> <p>Screw (42pcs)</p>	<p>H</p>  <p>Power socket (1pc)</p>	<p>J</p>  <p>#3.5*12mm</p> <p>Screw (26pcs)</p>
<p>K</p>  <p>Ø35mm</p> <p>Small Wheel (8pcs)</p>	<p>L</p>  <p>#4*50mm</p> <p>Screw (4pcs)</p>	<p>R</p>  <p>Ø8mm</p> <p>Half-moon temple feathers (8pcs)</p>

Step 1:

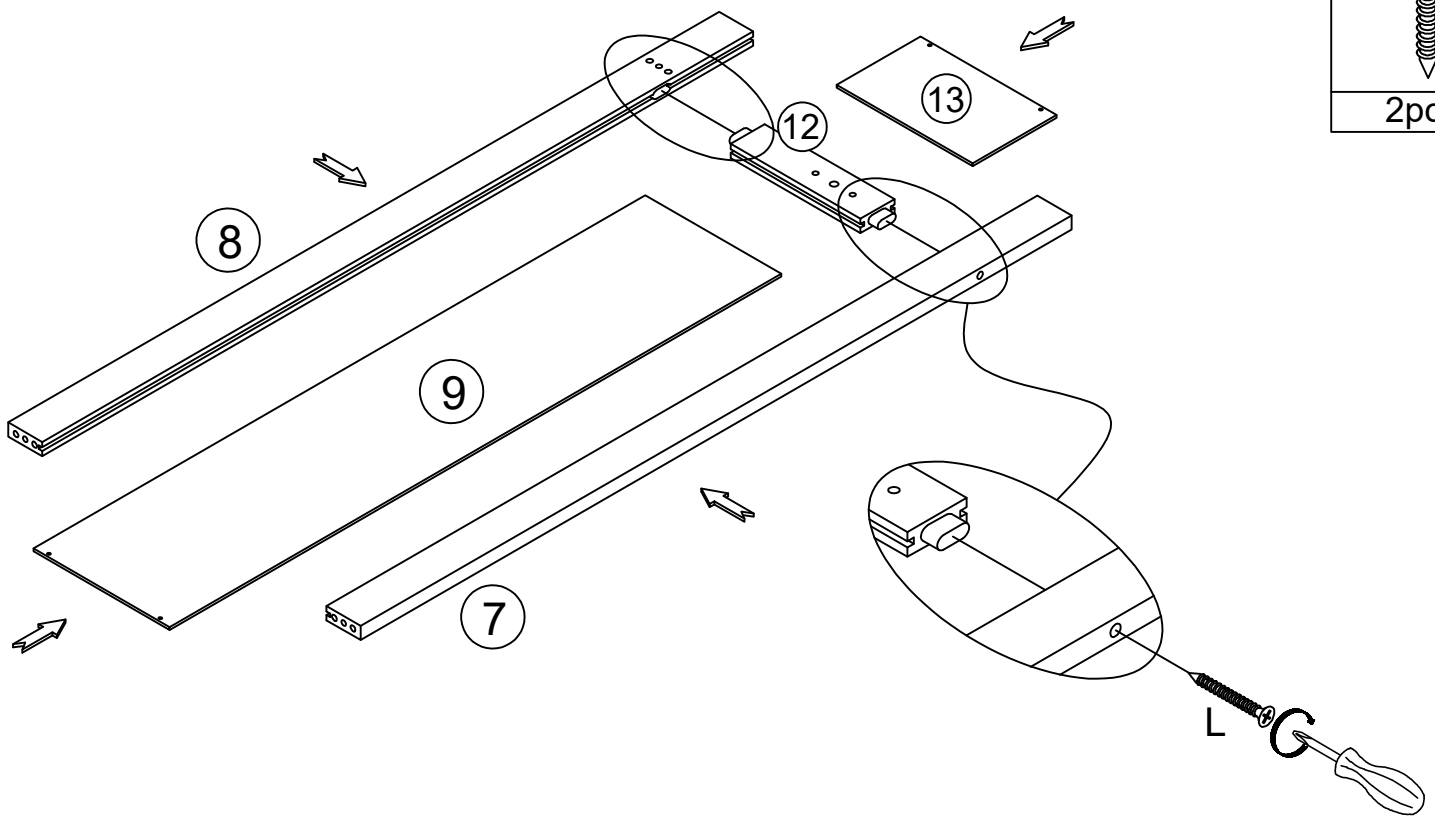

L	
2pcs	

Step 2:

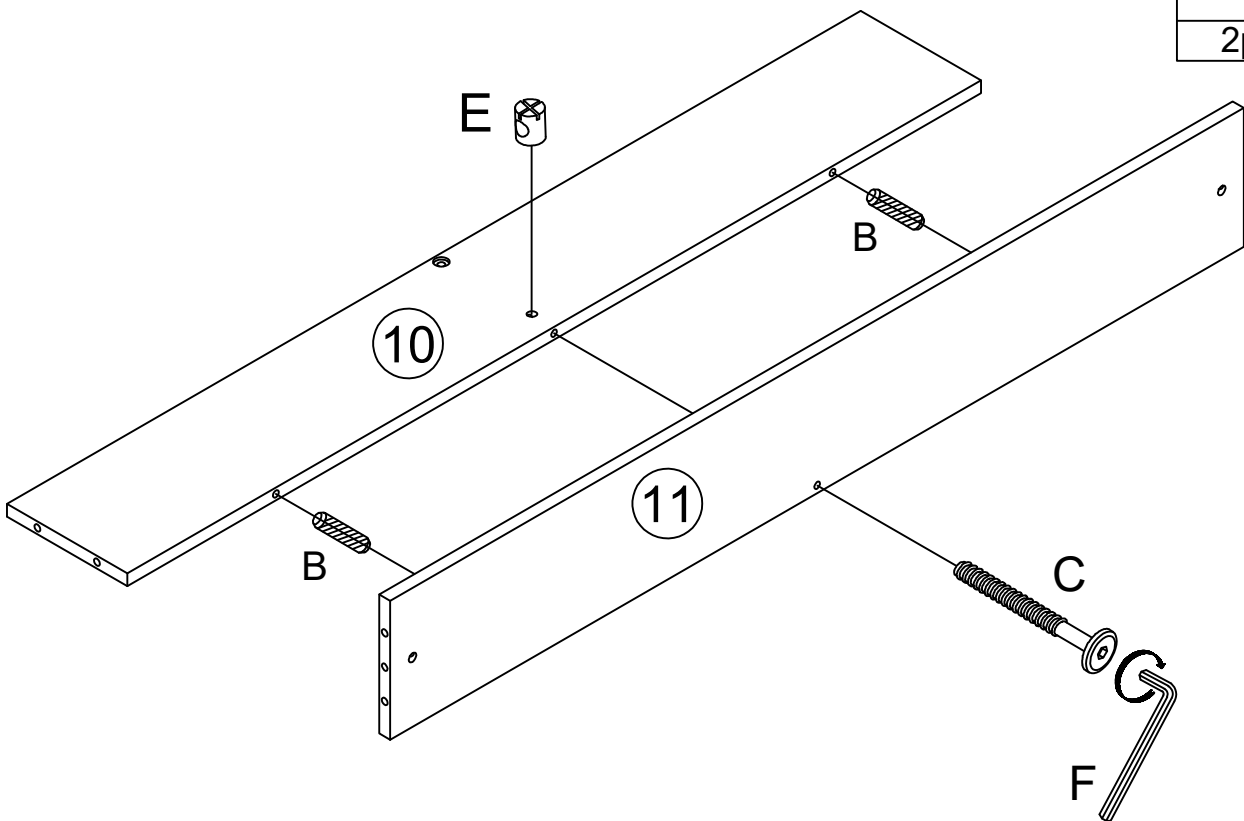

B		C	
2pcs		1pc	
E			
1pc			

Step 5:

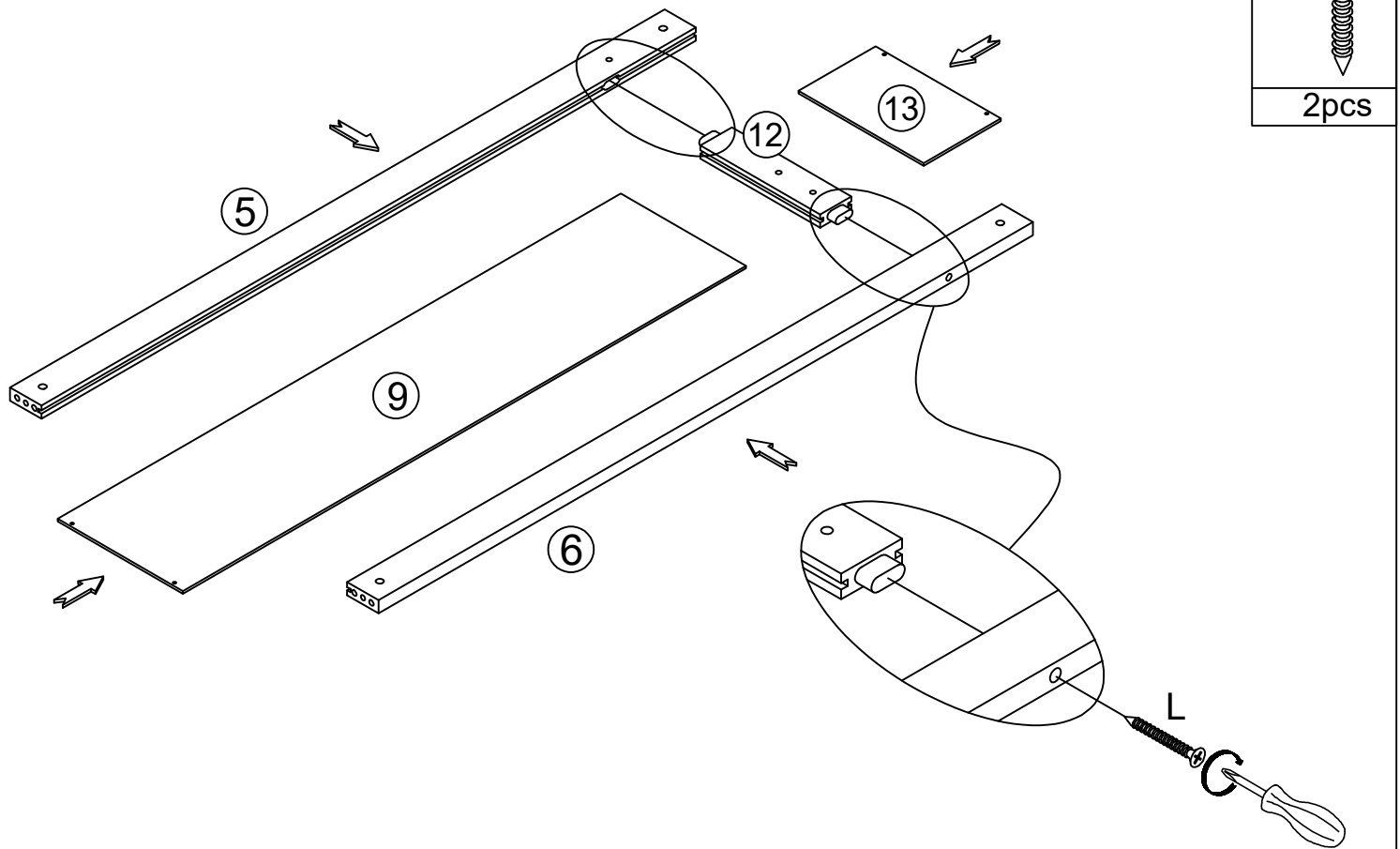

Step 6:

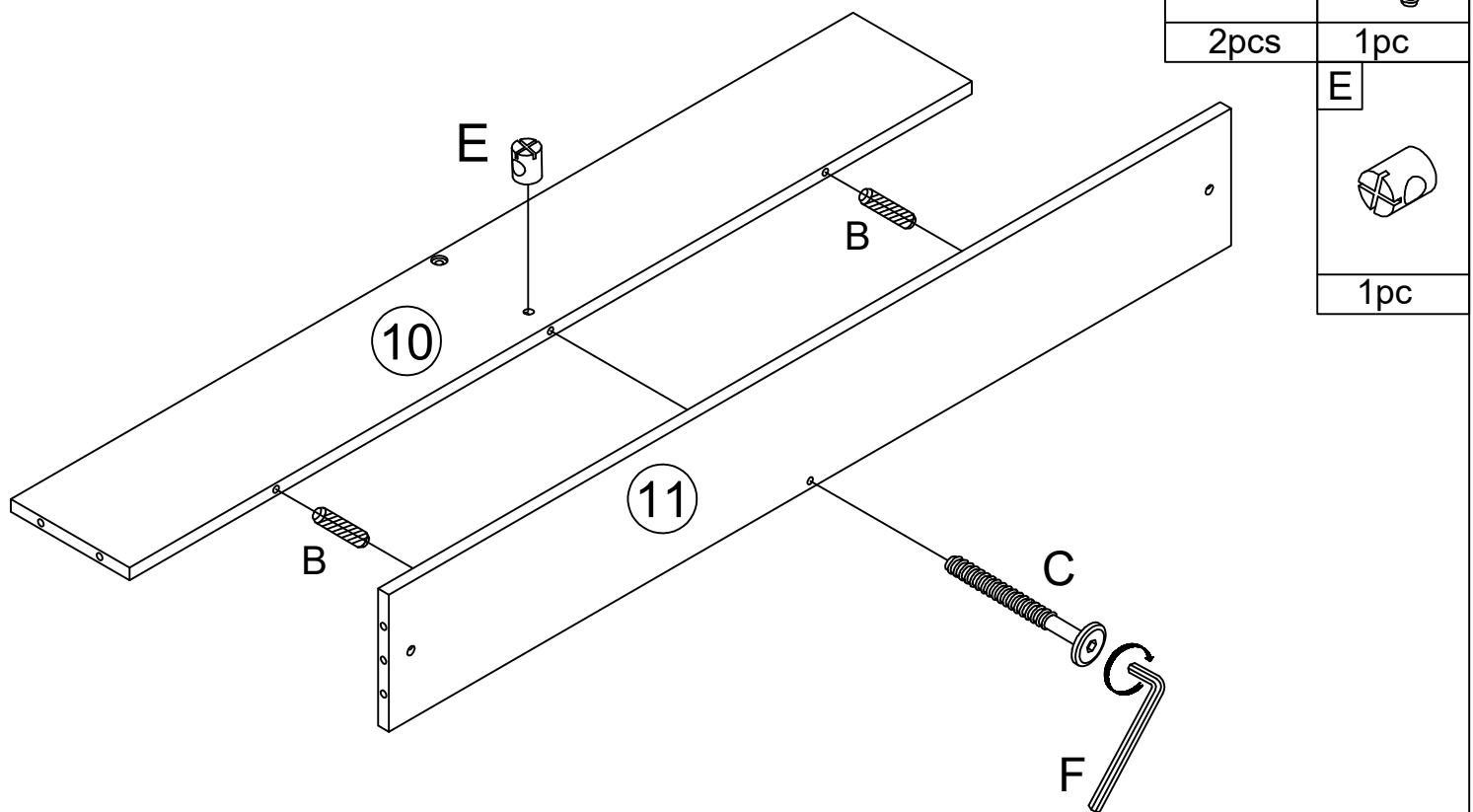

Step 7:

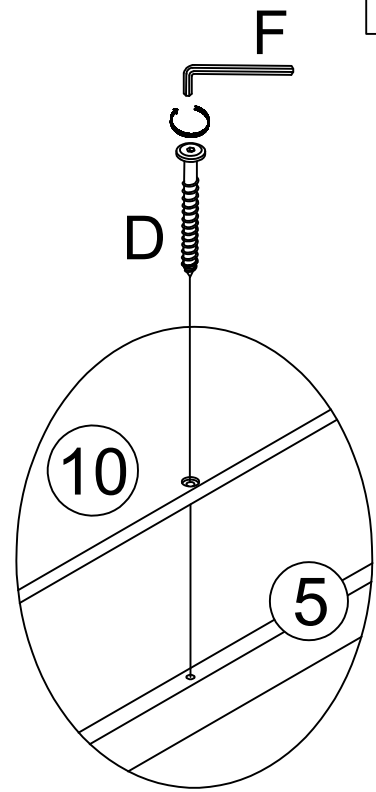
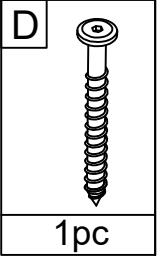
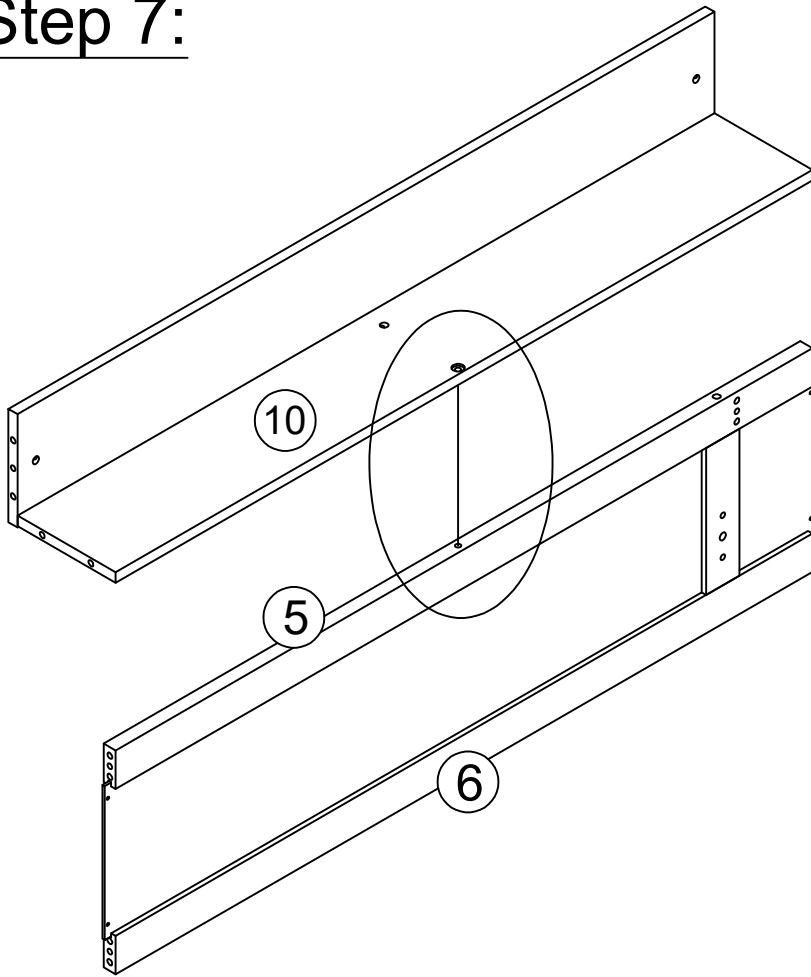

Step 8:

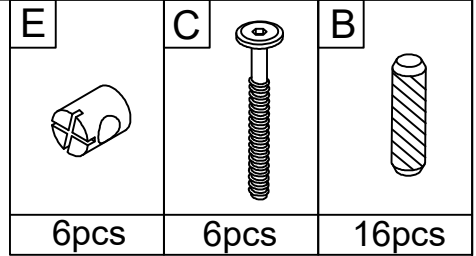
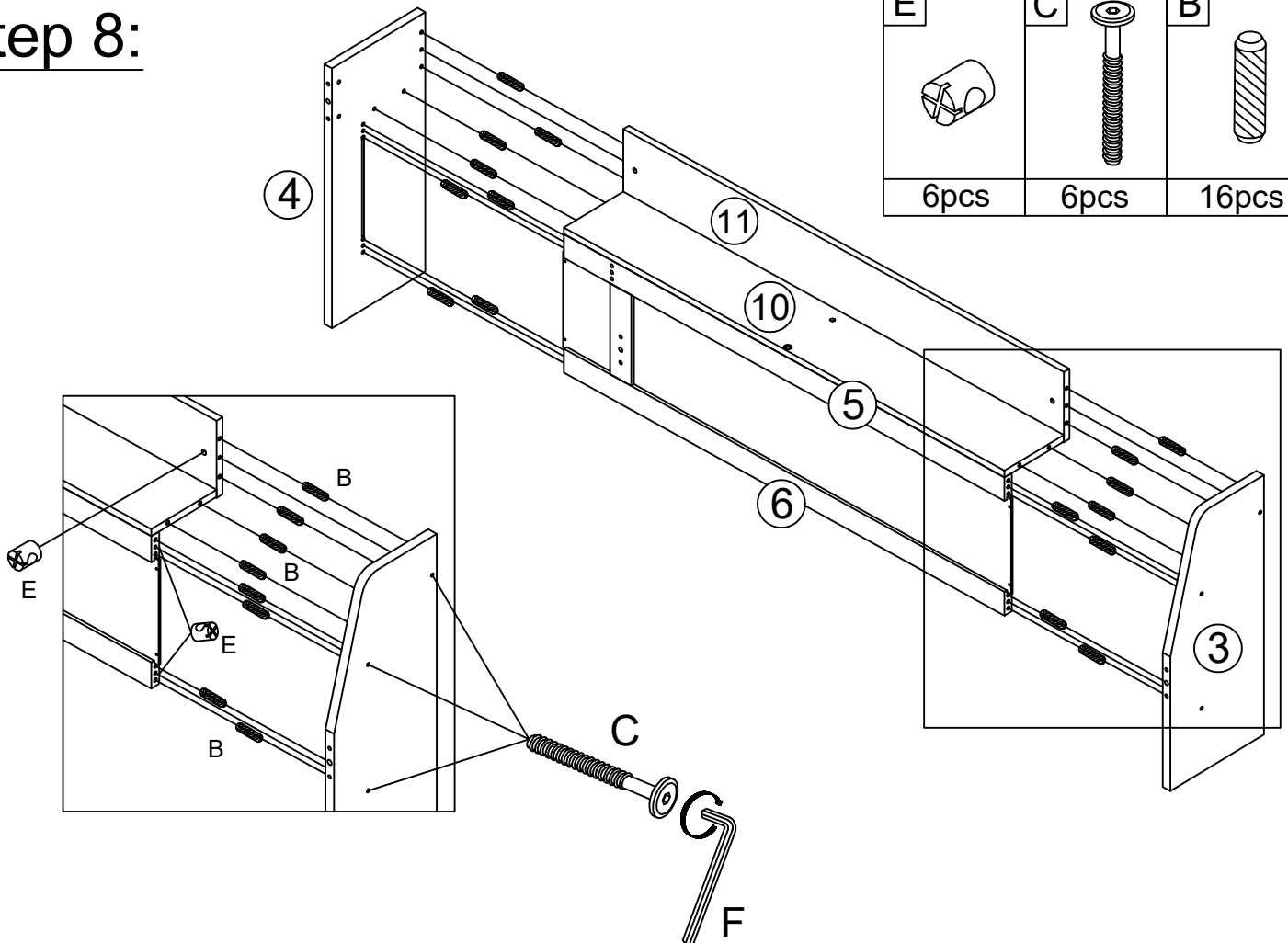

Step 9:

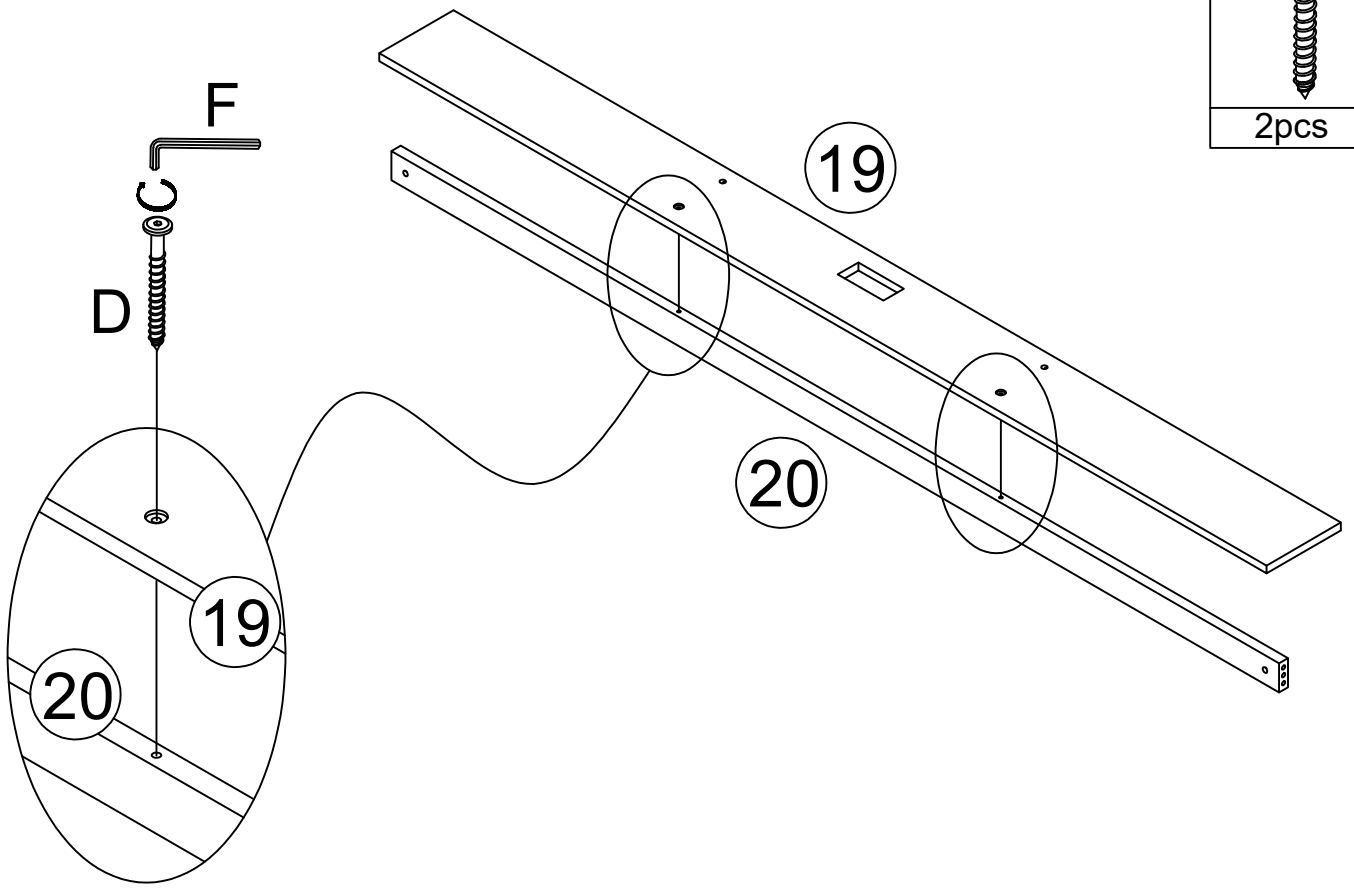

D	
2pcs	

Step 10:

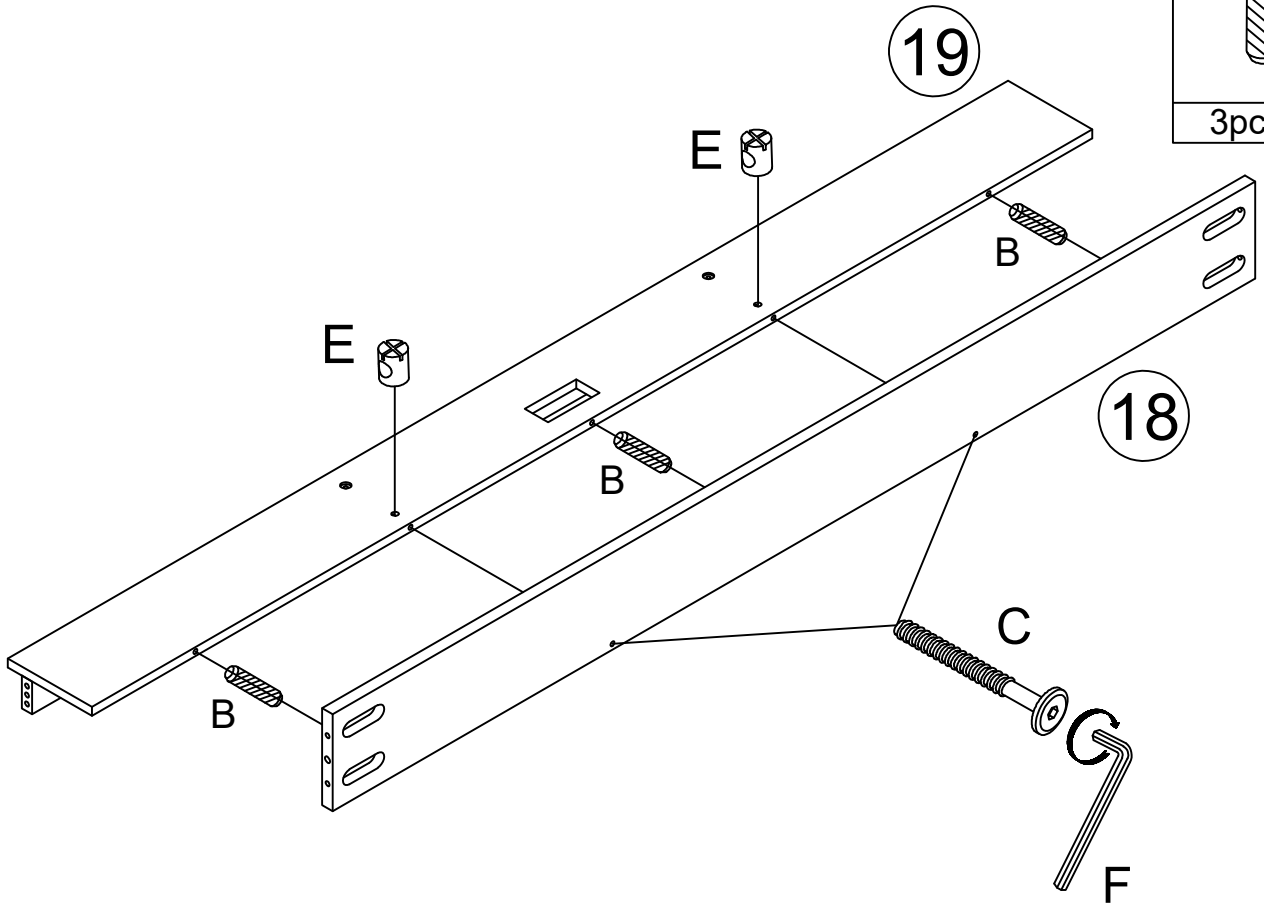



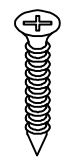

B		C	
3pcs		2pcs	
		E	
		2pcs	

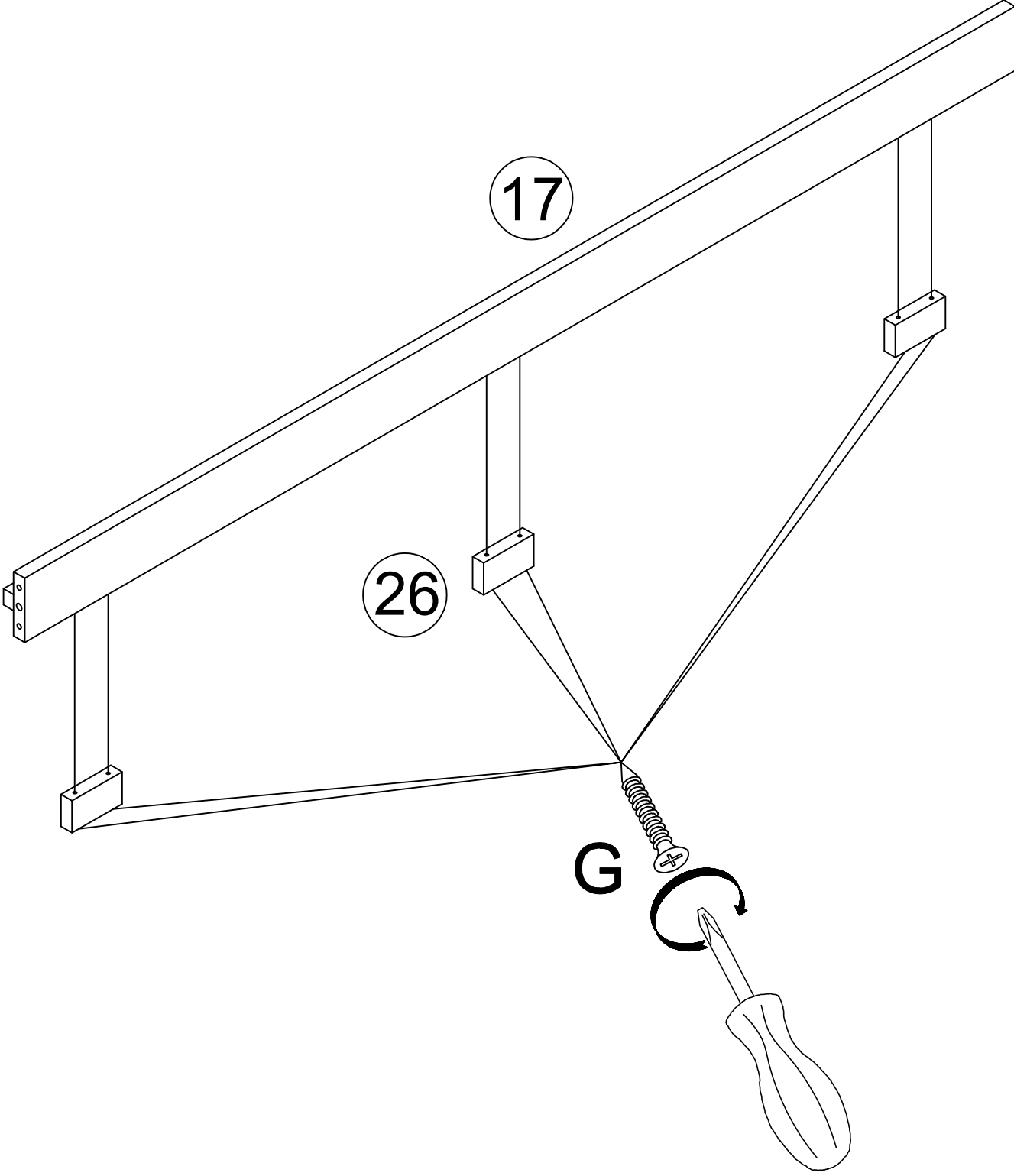
Step 11:

G	
6pcs	

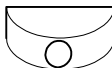

Step 12:

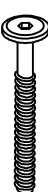
R	A	E	B	C
				
8pcs	6pcs	14pcs	4pcs	14pcs

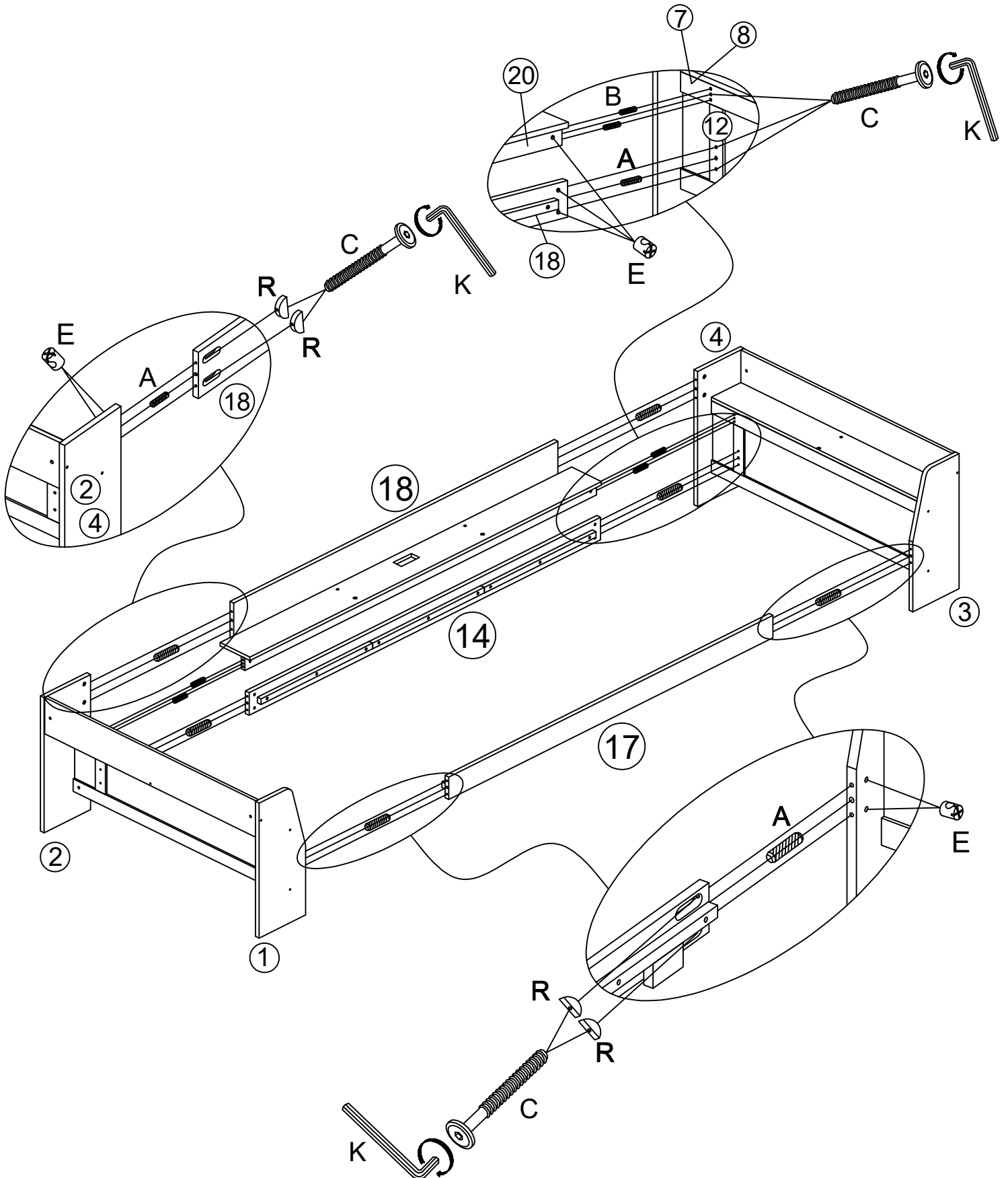

ATTENTION: PLEASE DON'T TIGHTEN ALL BOLTS IN THIS STEP, JUST TIGHTEN 80%

Step 13:

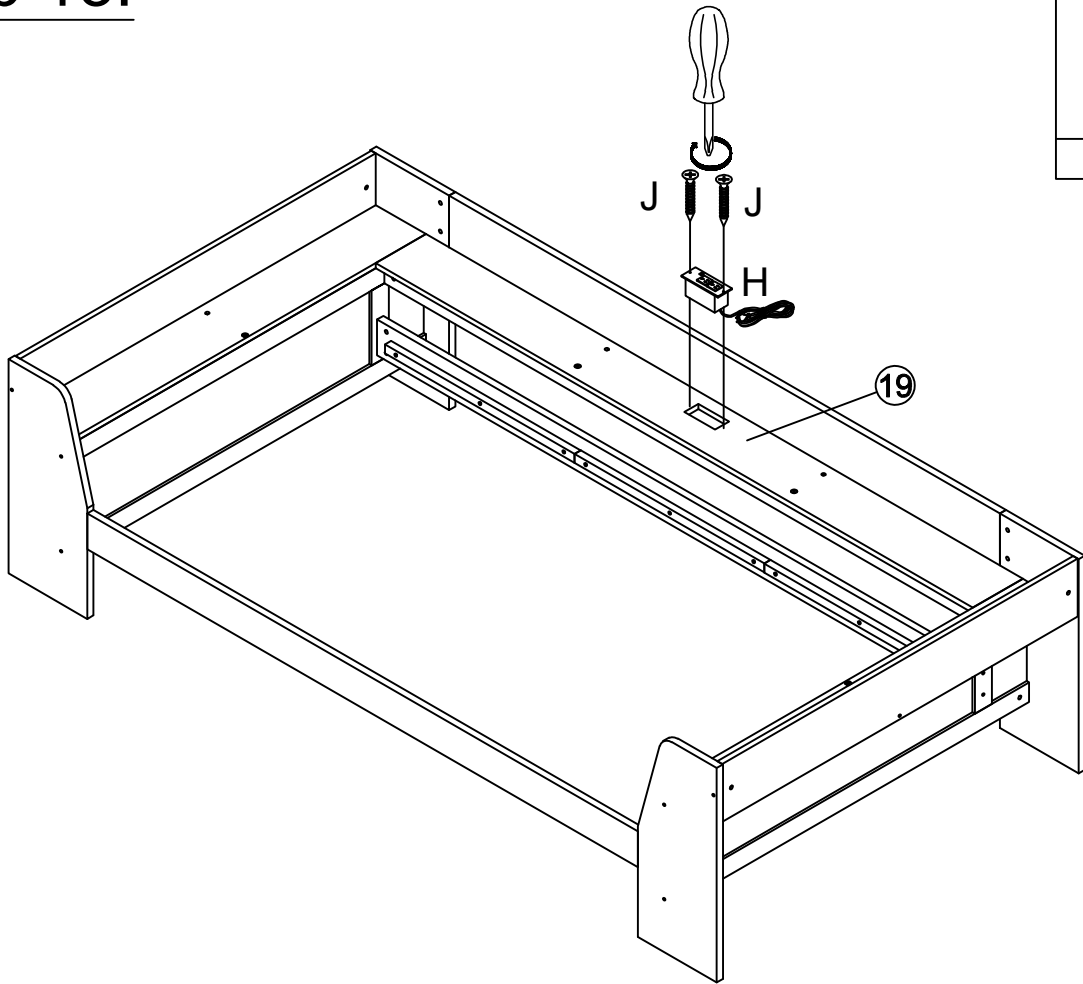

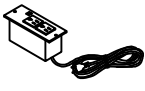
J	H
	
2pcs	1pc

Step 14:

STEP 2: SCREW ALL SLATS

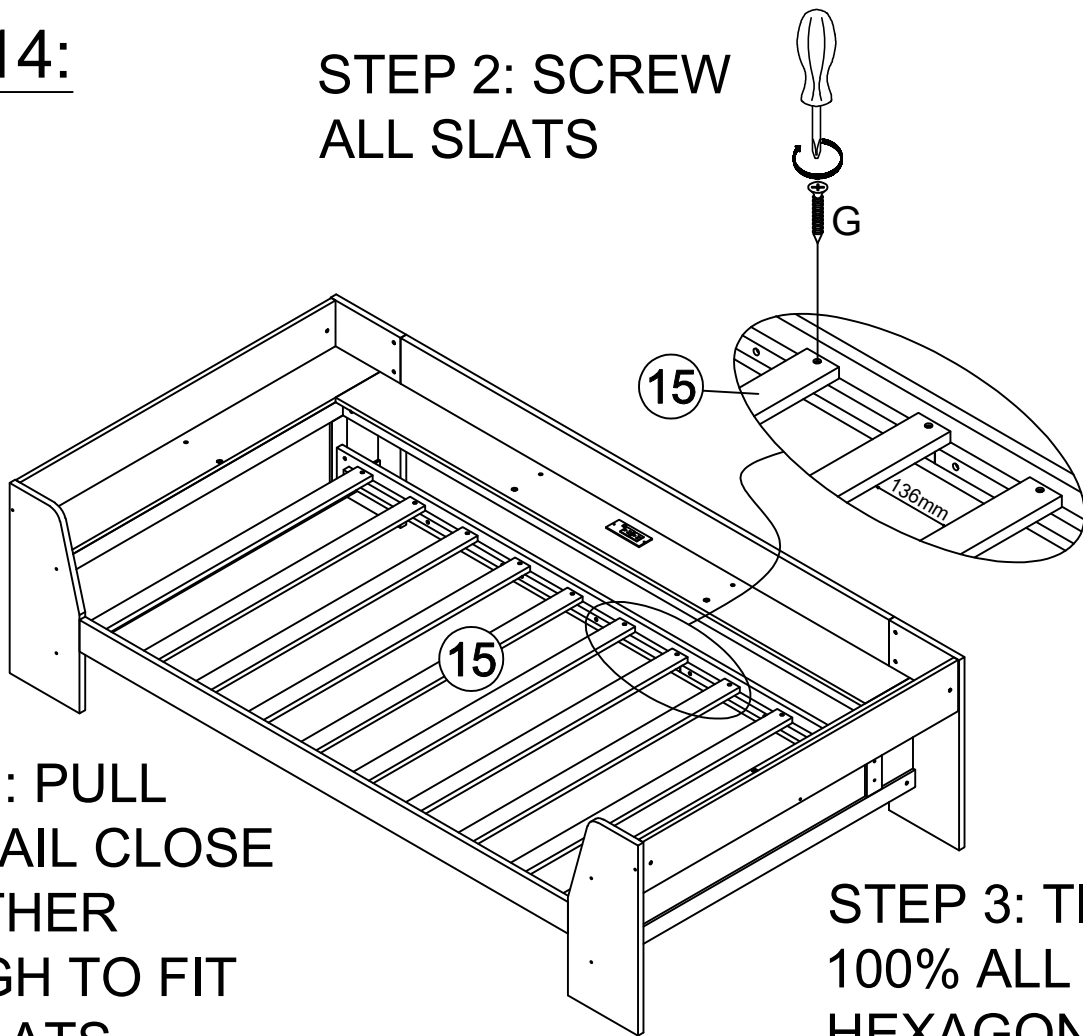

G

20pcs

STEP 1: PULL SIDE RAIL CLOSE TOGETHER ENOUGH TO FIT THE SLATS

STEP 3: TIGHTEN 100% ALL HEXAGON BOLTS

Step 15:

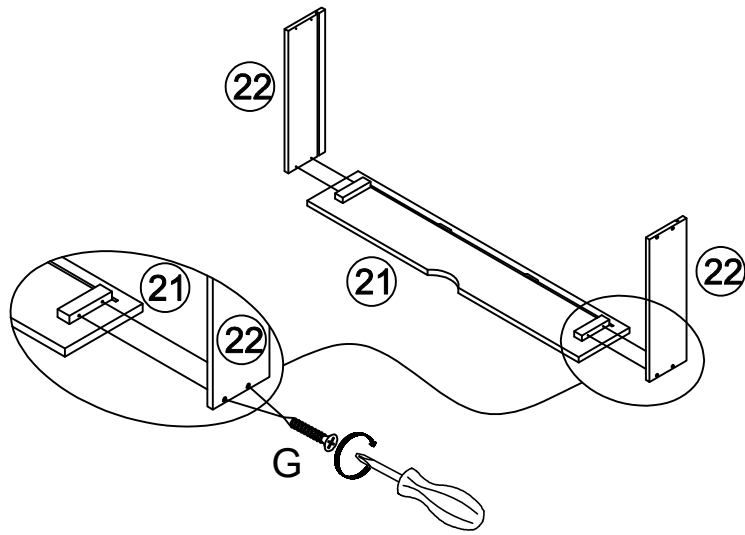
x2



G



8pcs

Step 16:

x2

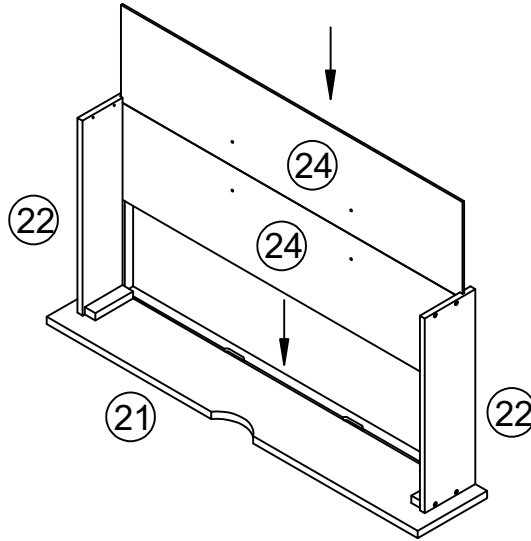

Step 17:

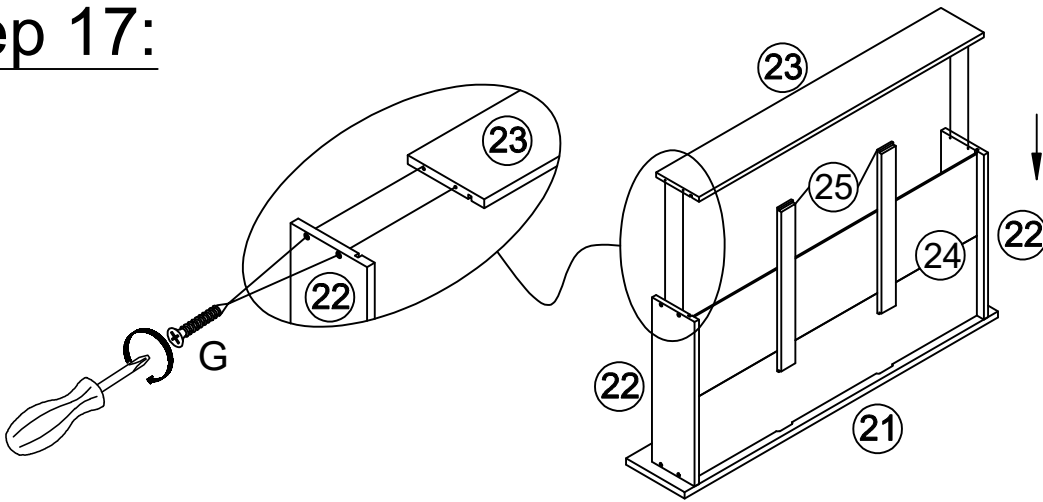

G



8pcs

x2

Step 18:

x2

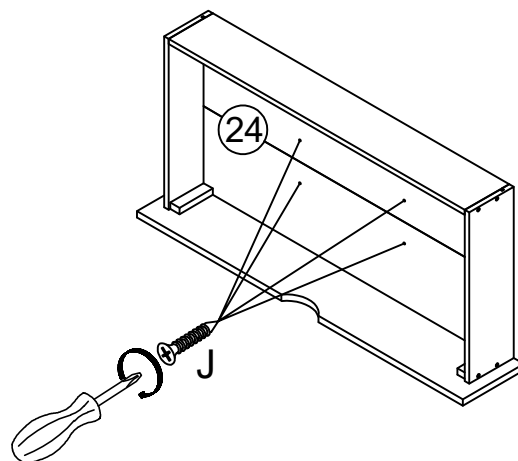

J



8pcs

Step 19:

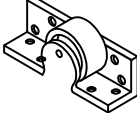
J	K
	
16pcs	8pcs

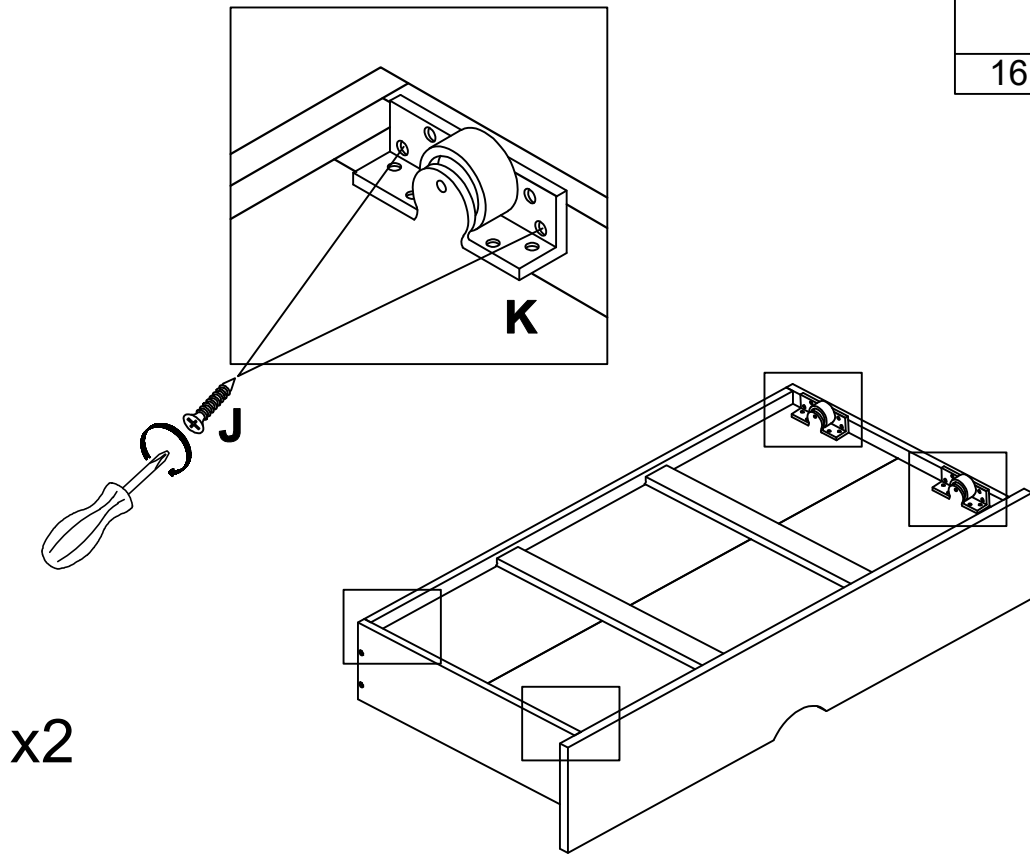

Step 20:

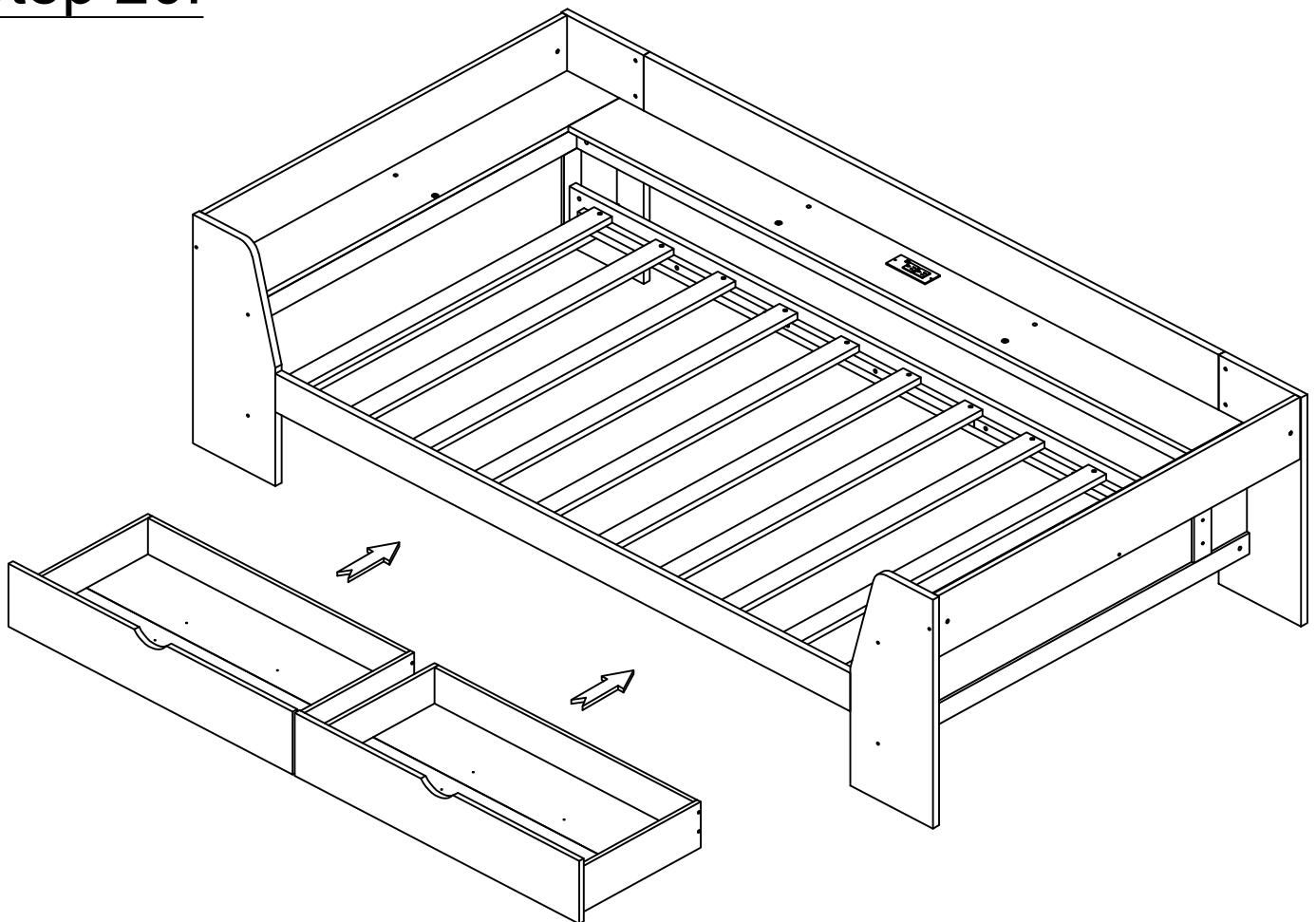

COMPLETED

