

ASSEMBLY INSTRUCTION

SKU CODE: (WF302888-WF302889-WF302890)

This set is included 3 boxes if don't receive full 3 boxes please contact our customer service team

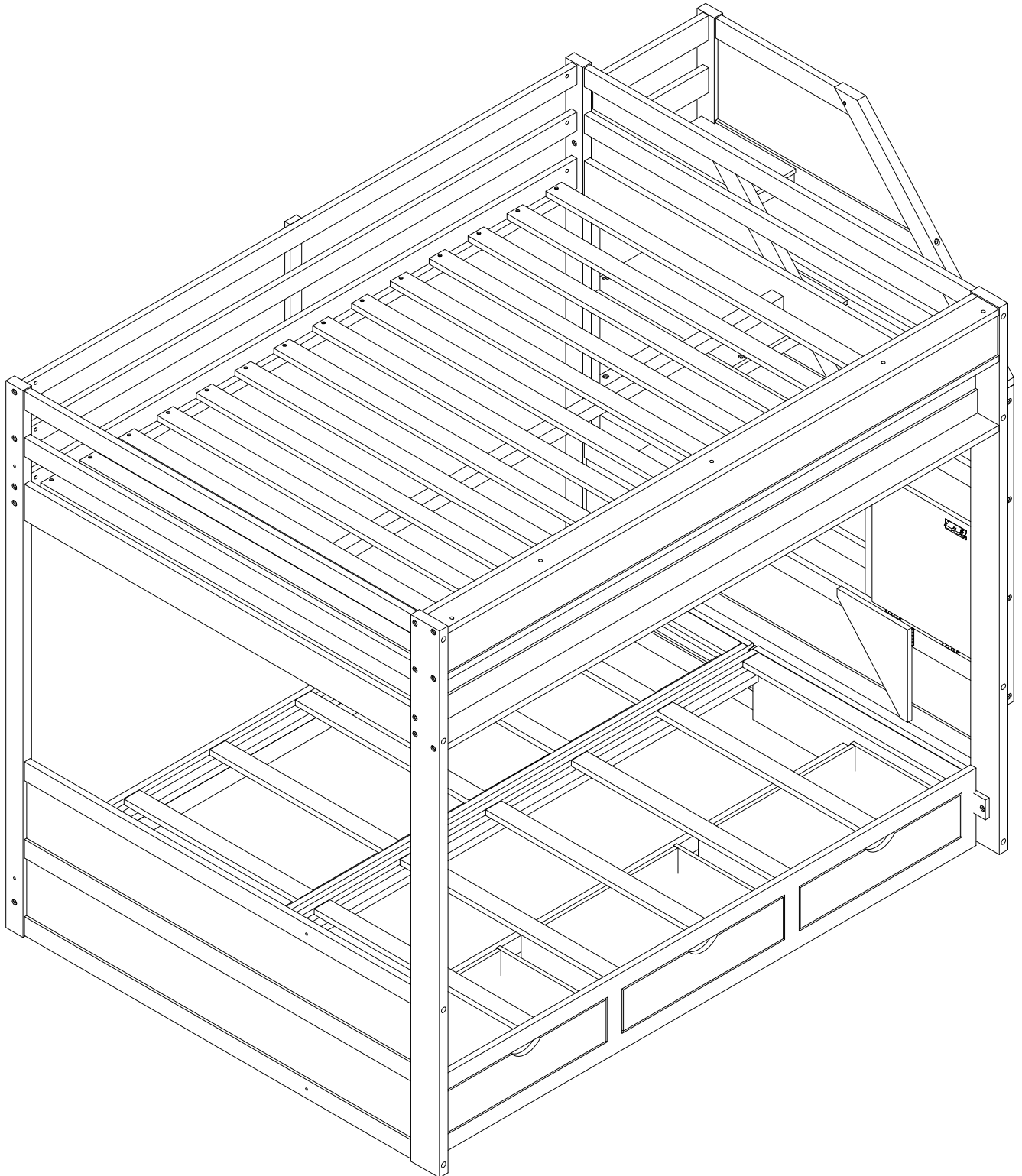

! SAFETY WARNINGS !

1. This bed is designed for use only mattress (es) meeting the following specifications on the upper bunk, and lower bunk

Upper bed

Bed Type	Length	Width	Thickness
<i>Full Standard</i>	<i>74" - 75"</i>	<i>53 1/2"</i>	<i>6" max</i>

Lower bed

Bed Type	Length	Width	Thickness
<i>Full Standard</i>	<i>74" - 75"</i>	<i>53 1/2"</i>	<i>8" max</i>

2. Replacement parts, including additional guardrails, maybe obtained from any of our (GIGACLOUD TECHNOLOGY (USA) INC. 18961 ARENTH AVENUE CITY OF INDUSTRY, CA, 91748) dealers
3. Follow the information on the warnings appearing on the upper bunk bed end structure and on the carton. Do not remove warning label from bed
4. Always use the recommended size mattresses or mattress supports, or both, to help prevent the likelihood of entrapment or falls.
5. Surface of mattress must be at least 5" (127mm) below the upper edge of guardrails
6. Do not allow children under 6 years of age to use the upper bunk.
7. Periodically check and ensure that the guardrail, ladder, and other components are in their proper position, free from damage, and that all connectors are tight.
8. Do not allow horseplay on or under the bed and prohibit jumping on the bed.
9. Always use the ladder for entering and leaving the upper bunk Always use the ladder for entering and leaving the upper bunk.
10. Do not use substitute part. Contact the manufacture or dealer for replacement part
11. Use of a night light may provide added safety precaution for a child using the upper bunk..
12. Always use guardrails on both long sides of the upper bunk. If the bunk bed will be placed next to the wall, the guardrail that runs the full length of the bed should be placed against the wall to prevent entrapment between the bed and wall.
13. The use of water or sleep flotation mattresses is prohibited
14. STRANGULATION HAZARD - Never attach or hang items to any part of the bunk bed that are not designed for use with the bed; for example, but not limited to, hook, belts and jump ropes
15. Keep these instruction for future reference
16. Prohibit more than one person on upper bunk
17. We recommend assembling your bunk bed on the shipping carton to protect your floor or carpet
18. Be certain all staples are out of the box before beginning assembly on the shipping carton.

OPTION 1

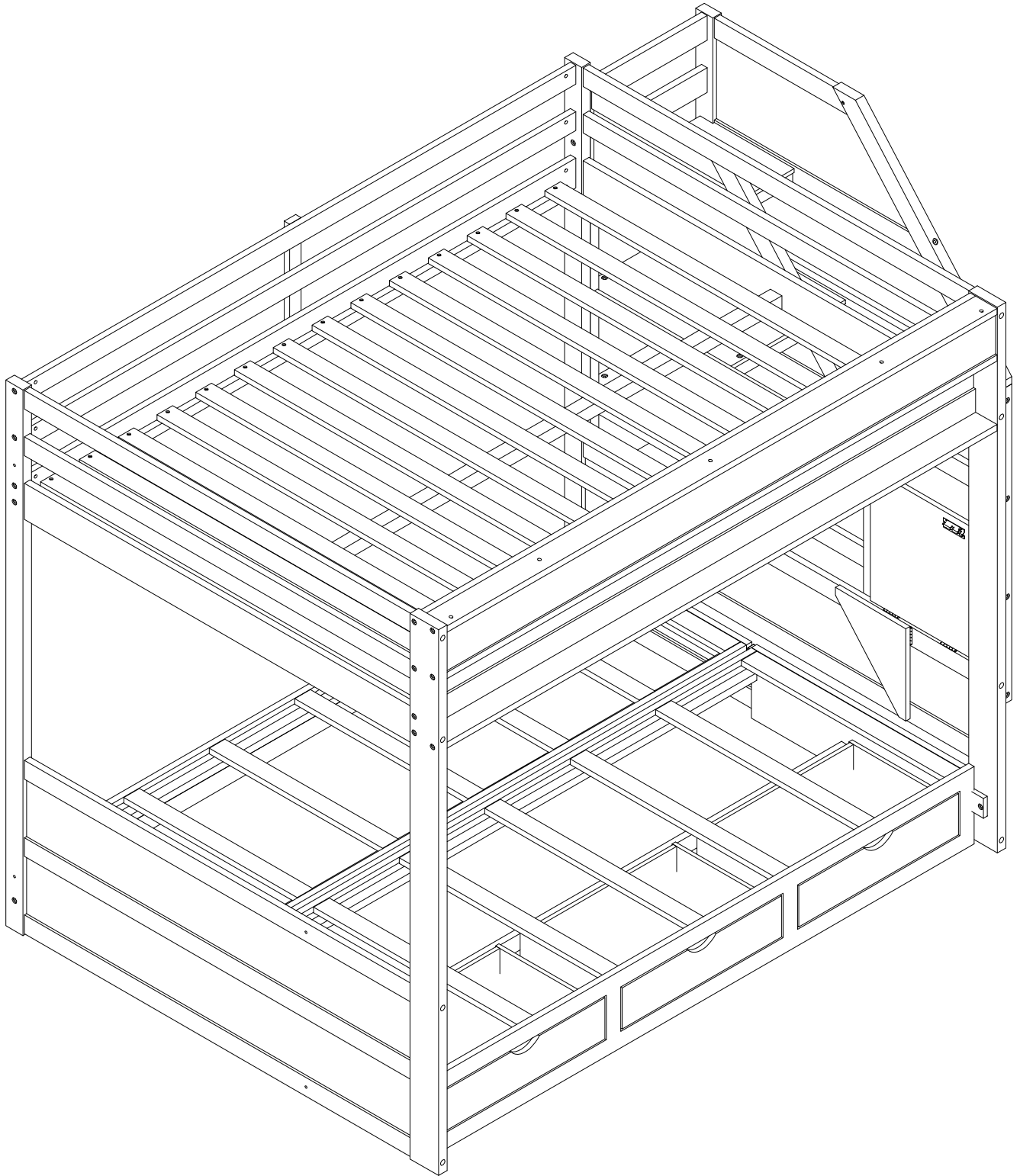

OPTION 2

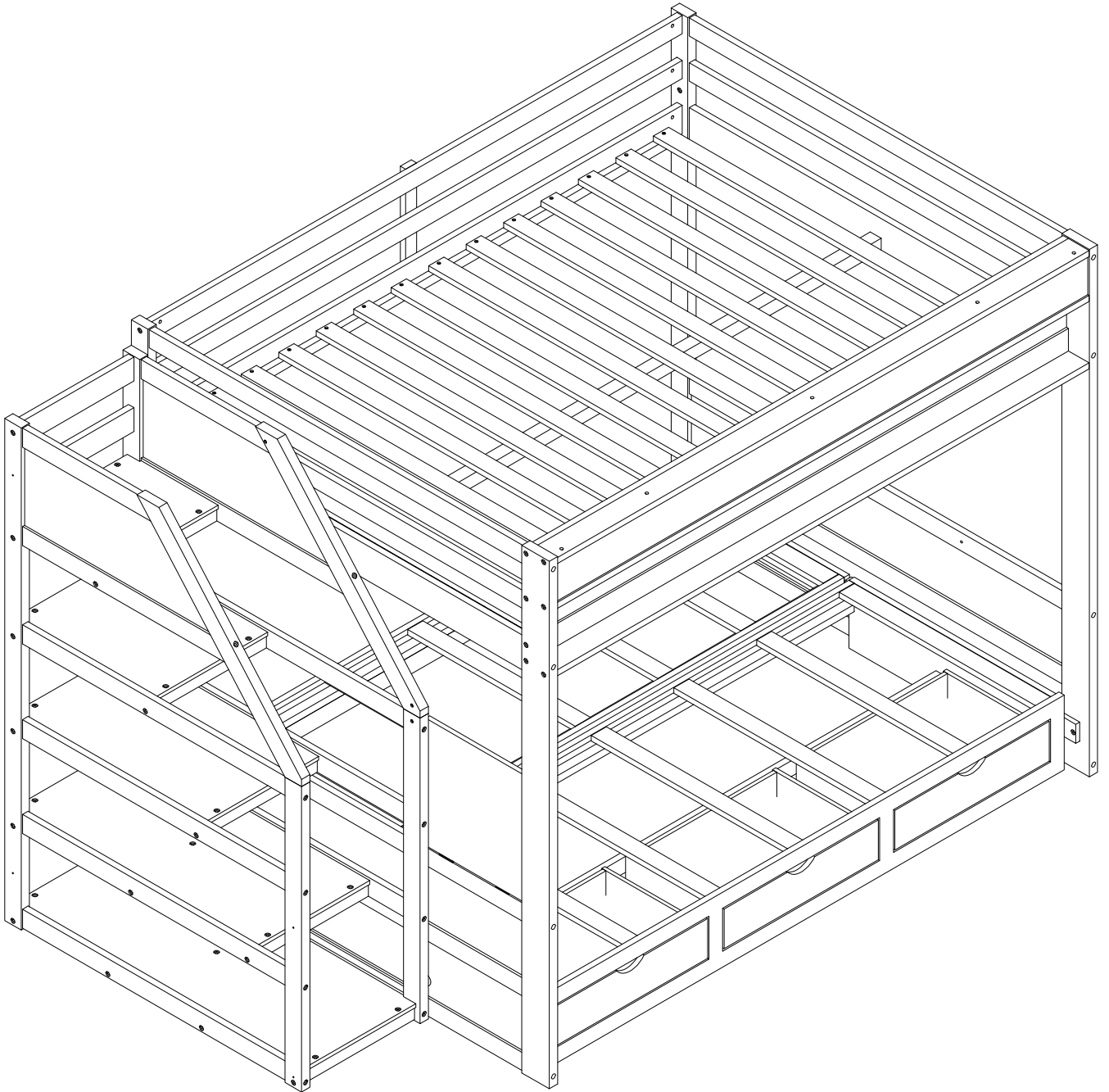

OPTION 3

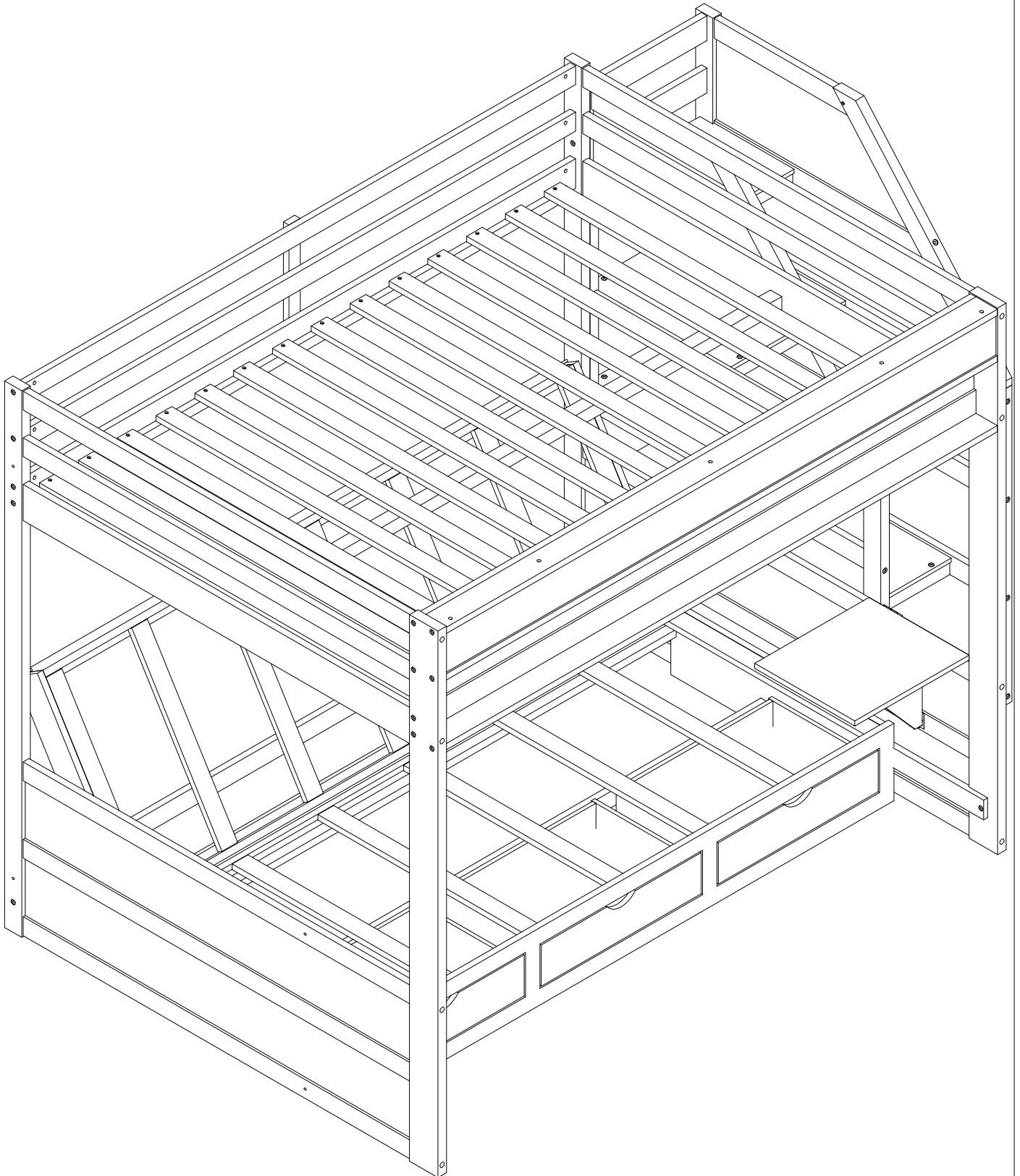



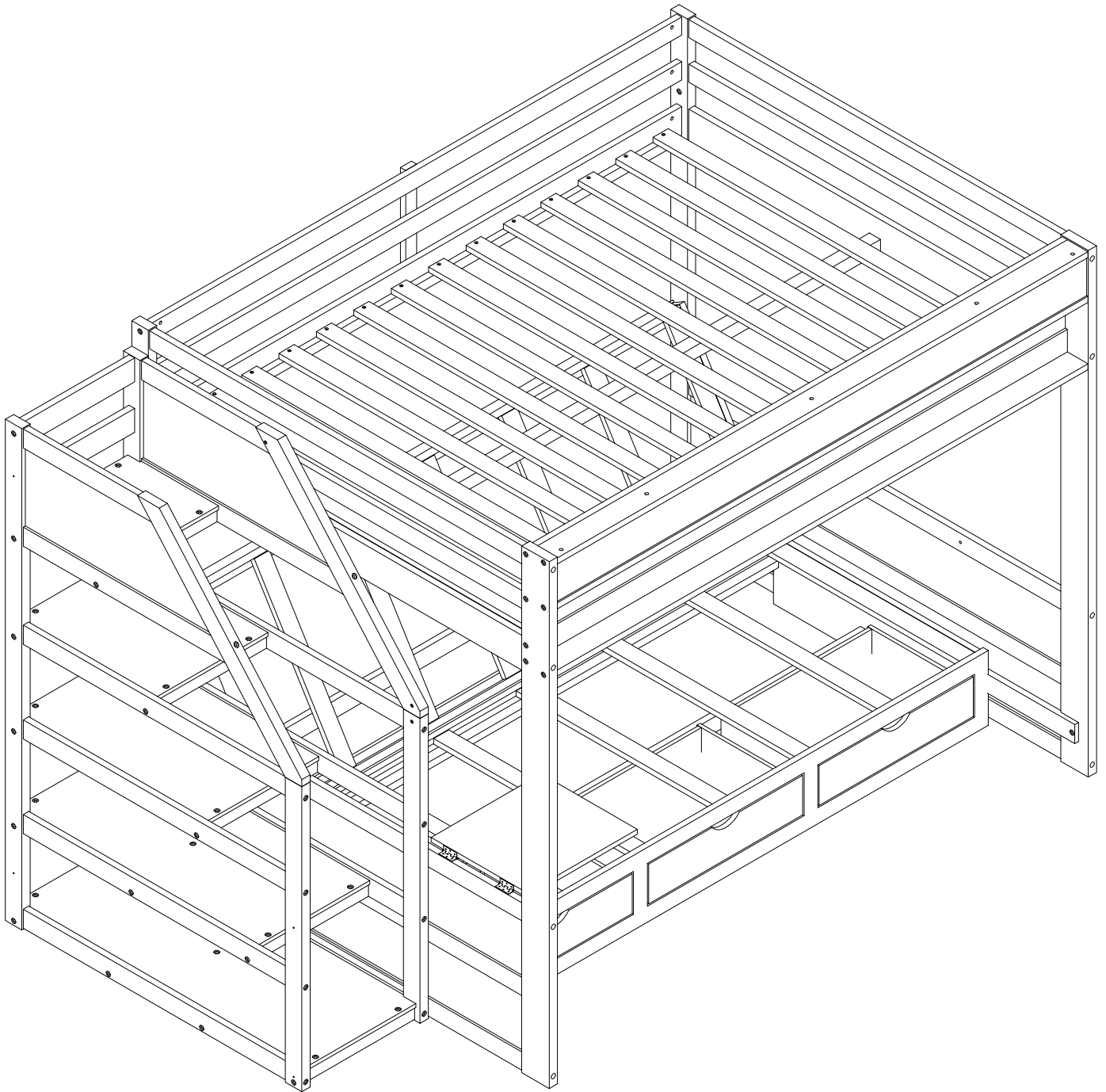



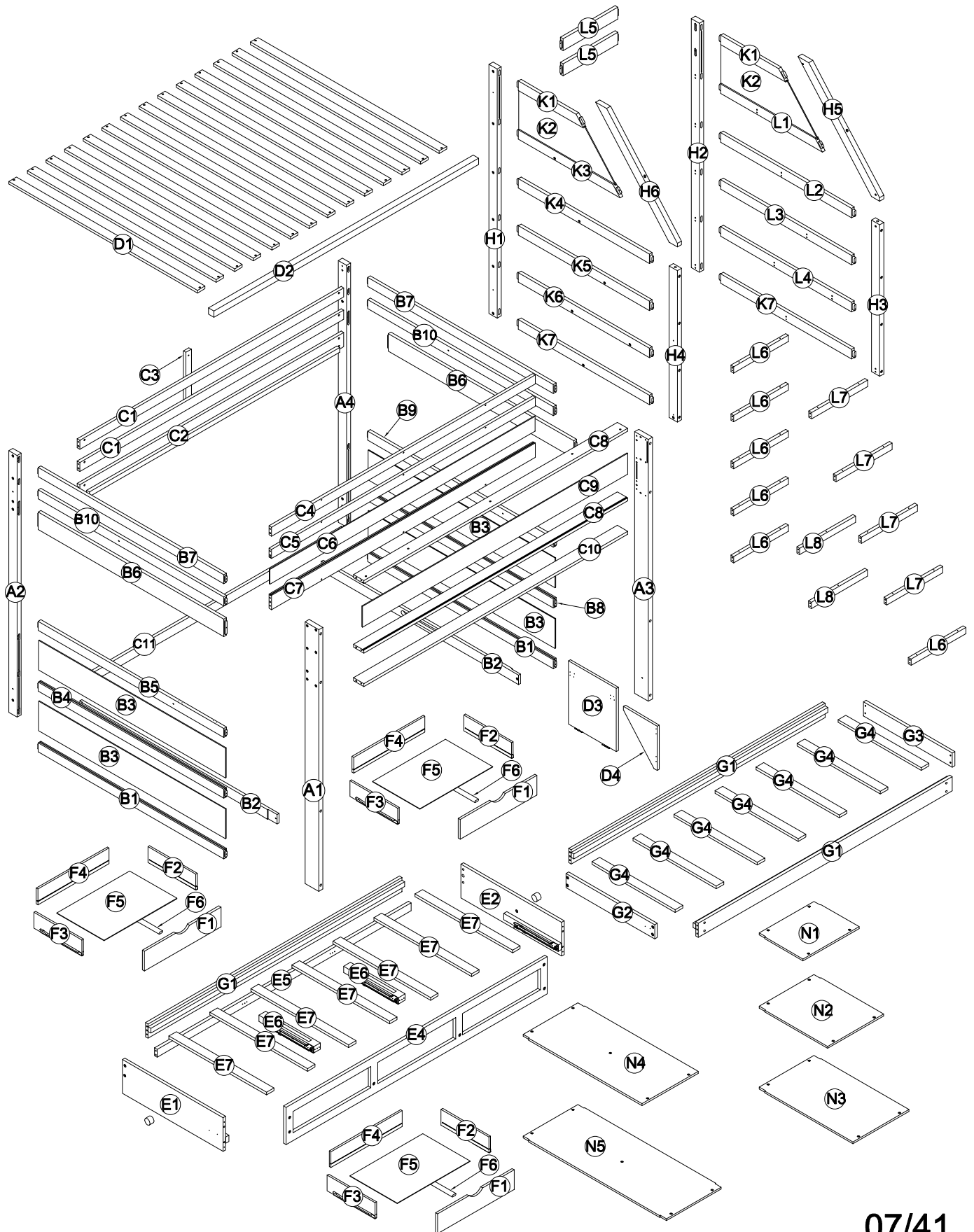

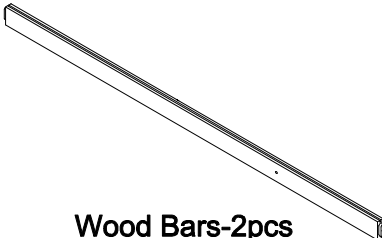
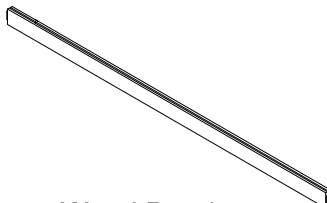
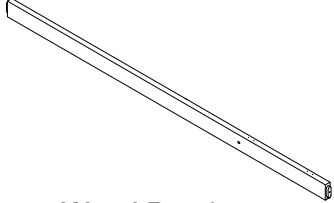

OPTION 4

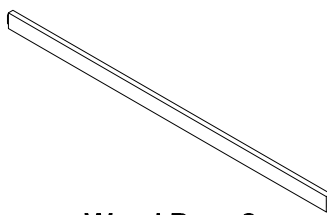

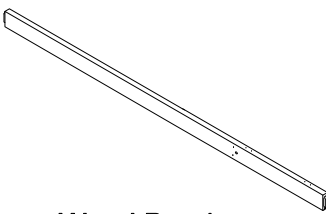

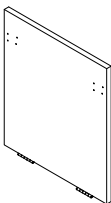
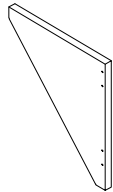
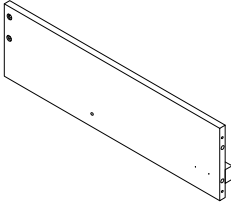
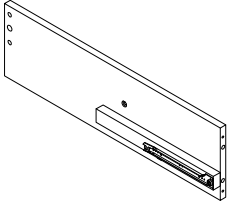
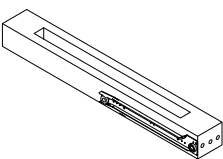
ASSEMBLY INSTRUCTION

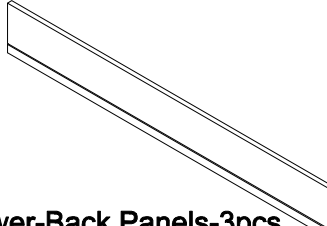
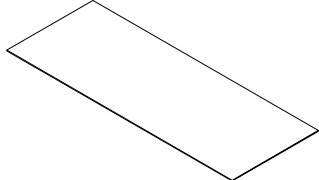
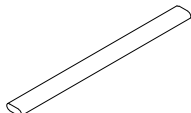
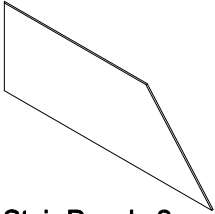
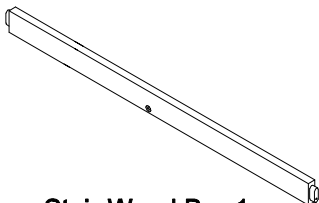

Part List (Box 1-WF302888)

<p>B1</p>  <p>Wood Bars-2pcs</p>	<p>B4</p>  <p>Wood Bar-1pc</p>	<p>B5</p>  <p>Wood Bar-1pc</p>
<p>B6</p>  <p>Wood Bars-2pcs</p>	<p>B7</p>  <p>Wood Bars-2pcs</p>	<p>B8</p>  <p>Wood Bar-1pc</p>
<p>B9</p>  <p>Wood Bar-1pc</p>	<p>C3</p>  <p>Rail(back)-1pc</p>	<p>D3</p>  <p>Table-Top Panel-1pc</p>
<p>D4</p>  <p>Table-Bottom Panel-1pc</p>	<p>E1</p>  <p>Trundle-Side Panel-1pc</p>	<p>E2</p>  <p>Trundle-Side Panel-1pc</p>
<p>E6</p>  <p>Trundle-Center Rails-2pcs</p>	<p>E7</p>  <p>Trundle-Slats-7pcs</p>	<p>G4</p>  <p>Trundle-Slats-7pcs</p>
<p>F4</p>  <p>Drawer-Back Panels-3pcs</p>	<p>F5</p>  <p>Drawer-Bottom Panels-3pcs</p>	<p>F6</p>  <p>Drawer-Support Bottom Panels-3pcs</p>
<p>K2</p>  <p>Stair-Panels-2pcs</p>	<p>K4</p>  <p>Stair-Wood Bar-1pc</p>	<p>K5</p>  <p>Stair-Wood Bar-1pc</p>

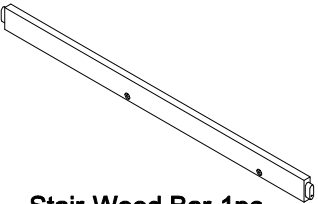
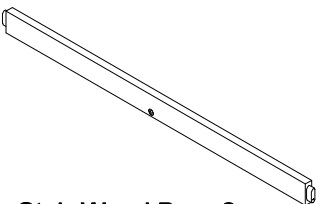
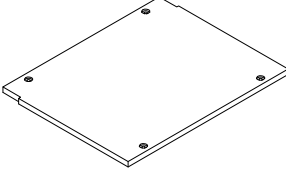
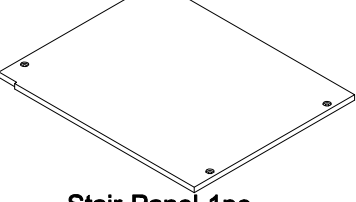
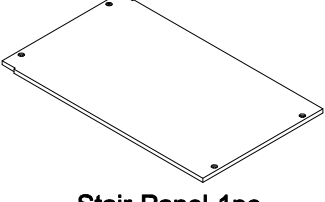
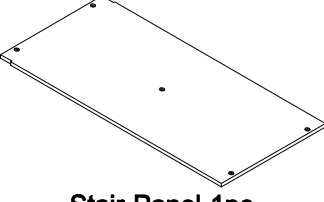
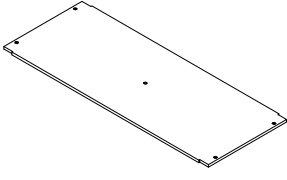
Part List (Box 1-WF302888)

K6  Stair-Wood Bar-1pc	K7  Stair-Wood Bars-2pcs	N1  Stair-Panel-1pc
N2  Stair-Panel-1pc	N3  Stair-Panel-1pc	N4  Stair-Panel-1pc
N5  Stair-Panel-1pc	B10  Wood Bars-2pcs	



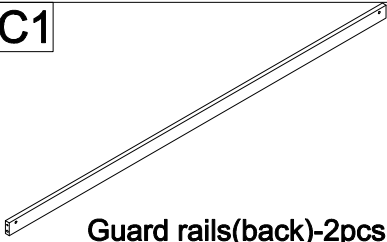
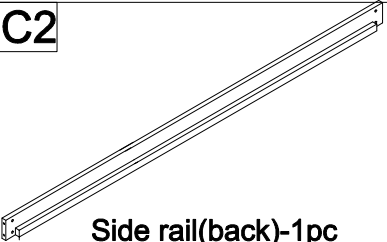
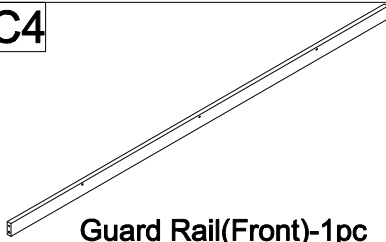
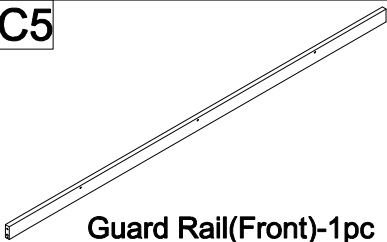
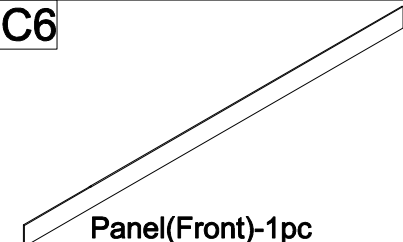
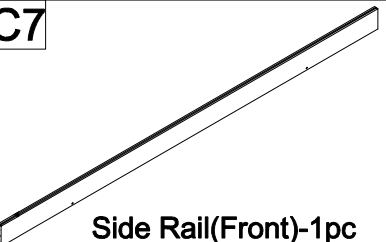
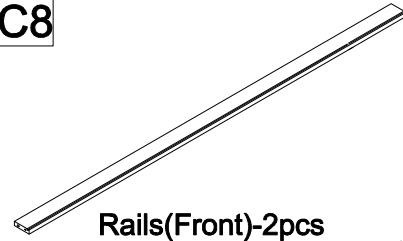
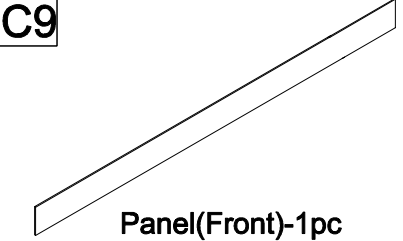
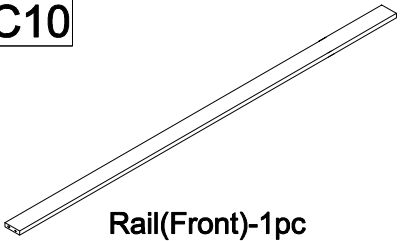
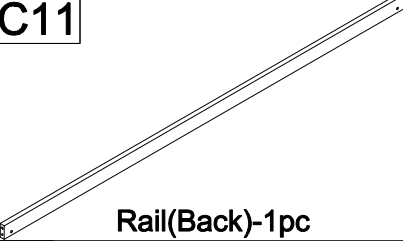
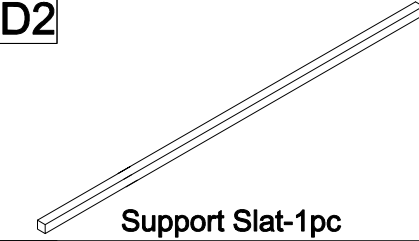
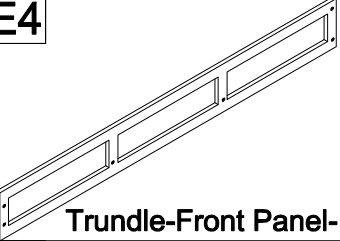
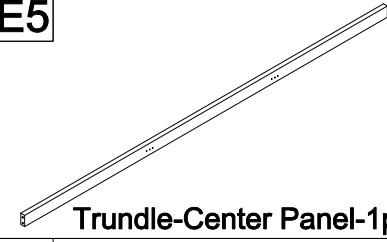
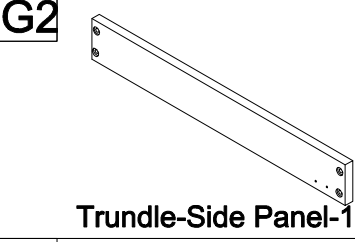
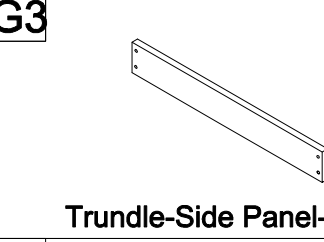
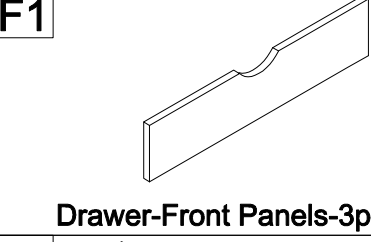
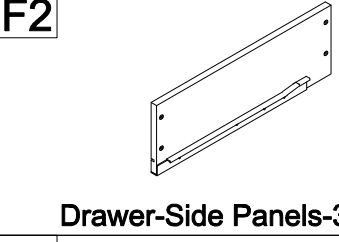
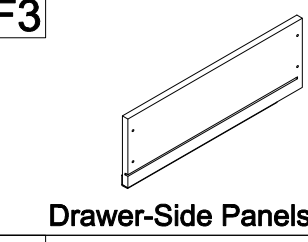
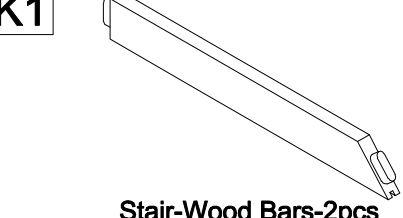
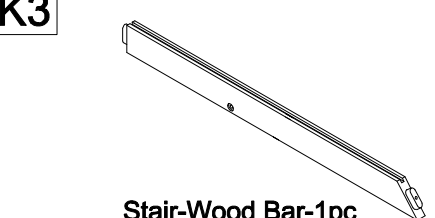
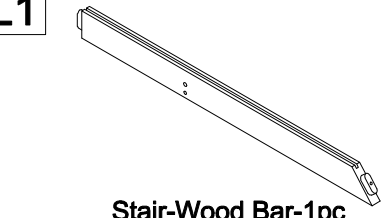



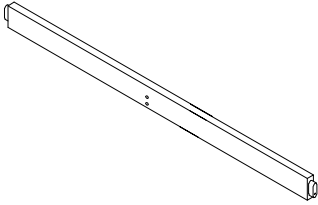
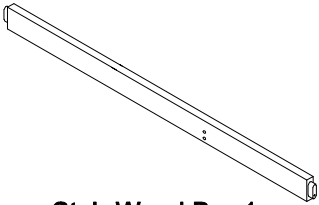
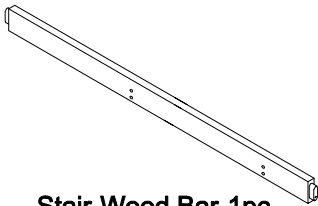
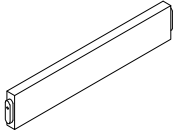
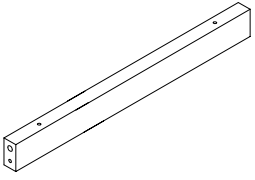
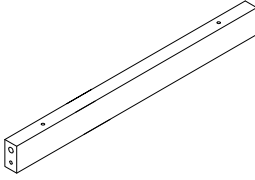
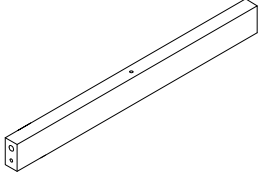
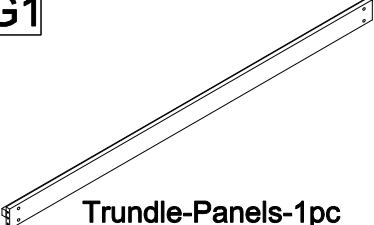

Part List (Box 2-WF302889)

<p>C1</p>  <p>Guard rails(back)-2pcs</p>	<p>C2</p>  <p>Side rail(back)-1pc</p>	<p>C4</p>  <p>Guard Rail(Front)-1pc</p>
<p>C5</p>  <p>Guard Rail(Front)-1pc</p>	<p>C6</p>  <p>Panel(Front)-1pc</p>	<p>C7</p>  <p>Side Rail(Front)-1pc</p>
<p>C8</p>  <p>Rails(Front)-2pcs</p>	<p>C9</p>  <p>Panel(Front)-1pc</p>	<p>C10</p>  <p>Rail(Front)-1pc</p>
<p>C11</p>  <p>Rail(Back)-1pc</p>	<p>D2</p>  <p>Support Slat-1pc</p>	<p>E4</p>  <p>Trundle-Front Panel-1pc</p>
<p>E5</p>  <p>Trundle-Center Panel-1pc</p>	<p>G2</p>  <p>Trundle-Side Panel-1pc</p>	<p>G3</p>  <p>Trundle-Side Panel-1pc</p>
<p>F1</p>  <p>Drawer-Front Panels-3pcs</p>	<p>F2</p>  <p>Drawer-Side Panels-3pcs</p>	<p>F3</p>  <p>Drawer-Side Panels-3pcs</p>
<p>K1</p>  <p>Stair-Wood Bars-2pcs</p>	<p>K3</p>  <p>Stair-Wood Bar-1pc</p>	<p>L1</p>  <p>Stair-Wood Bar-1pc</p>



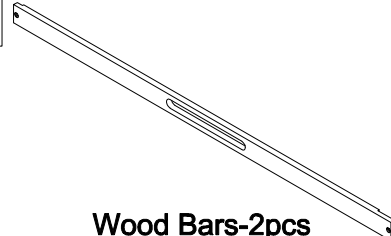
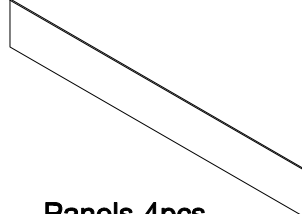
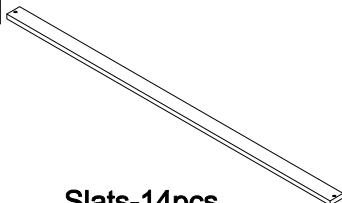
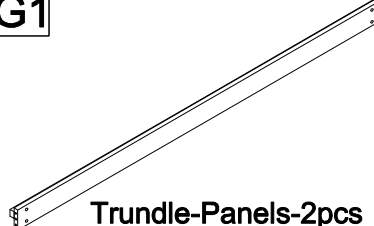



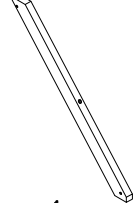
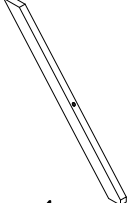



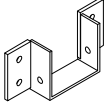
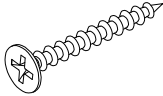

Part List (Box 2-WF302889)

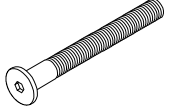
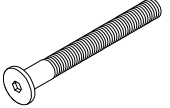
L2  Stair-Wood Bar-1pc	L3  Stair-Wood Bar-1pc	L4  Stair-Wood Bar-1pc
L5  Stair-Wood Bars-2pcs	L6  Stair-Wood Bars-6pcs	L7  Stair-Wood Bars-4pcs
L8  Stair-Wood Bars-2pcs	G1  Trundle-Panels-1pc	

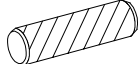
Part List & Hardware List (Box 3-WF302890)

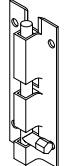
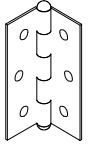
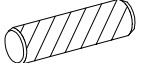
<p>A1</p>  <p>Leg-1pc</p>	<p>A2</p>  <p>Leg-1pc</p>	<p>A3</p>  <p>Leg-1pc</p>
<p>A4</p>  <p>Leg-1pc</p>	<p>B2</p>  <p>Wood Bars-2pcs</p>	<p>B3</p>  <p>Panels-4pcs</p>
<p>D1</p>  <p>Slats-14pcs</p>	<p>G1</p>  <p>Trundle-Panels-2pcs</p>	<p>H1</p>  <p>Stair-Leg-1pc</p>
<p>H2</p>  <p>Stair-Leg-1pc</p>	<p>H3</p>  <p>Stair-Leg-1pc</p>	<p>H4</p>  <p>Stair-Leg-1pc</p>
<p>H5</p>  <p>Stair-Leg-1pc</p>	<p>H6</p>  <p>Stair-Leg-1pc</p>	

Hardware List(Box 3-WF302890)

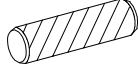
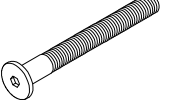
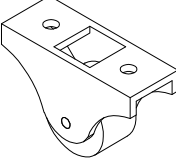
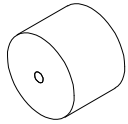
<p>1</p>  <p>Steel Bracket 2pc</p>	<p>2</p>  <p>M4 x 20 mm Wood Screws 38pcs</p>	<p>3</p>  <p>Screws 1/4" x80 30pcs</p>
<p>4</p>  <p>Screws 1/4" x100 8pcs</p>	<p>5</p>  <p>Screws 1/4" x30 29pcs</p>	<p>6</p>  <p>Ø1/4" x 60 mm Hex-Head bolts 22pcs</p>
<p>7</p>  <p>Ø1/4" x 80 mm Hex-Head bolts 27pcs</p>	<p>8</p>  <p>Ø1/4" x 13 mm Horizontal-Hole bolts 49pcs</p>	<p>9</p>  <p>Ø10 x 40 mm Wood dowel 32pcs</p>
<p>10</p>  <p>M4 x 30 mm Wood Screws 83pcs</p>	<p>11</p>  <p>M3 x 12 mm Wood Screws 22pcs</p>	<p>12</p>  <p>Stair latch-1pc</p>
<p>13</p>  <p>hinge leaf-2pcs</p>	<p>14</p>  <p>Ø12 x 70 mm Wood dowel 2pcs</p>	<p>15</p>  <p>Allen Key 1pc</p>
<p>16</p>  <p>Screws 1/4" x50 16pcs</p>	<p>17</p>  <p>Screws 1/4" x40 20pcs</p>	<p>18</p>  <p>Ø8 x 30 mm Wood dowel 32pcs</p>
<p>19</p>  <p>Ø1/4" x 40 mm Hex-Head bolts 2pcs</p>	<p>20</p>  <p>Wheels 4pcs</p>	<p>21</p>  <p>Slide Wood- 2pcs</p>

Hardware List(Box 3-WF302890)

22

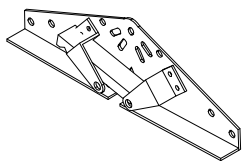

Bracket (Left)
-1pc

23

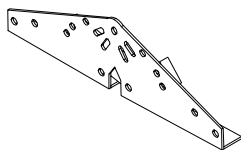

Bracket (Right)
-1pc

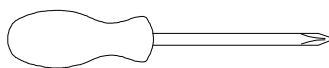

Assembly Tools Required (Not Included)

STEP 1: Following below illustration. .

Using hardware #2 connect Steel Bracket(#1) with B6 Wood bar.
Look at detail view for more detail

1	
	2pcs
2	
	8pcs

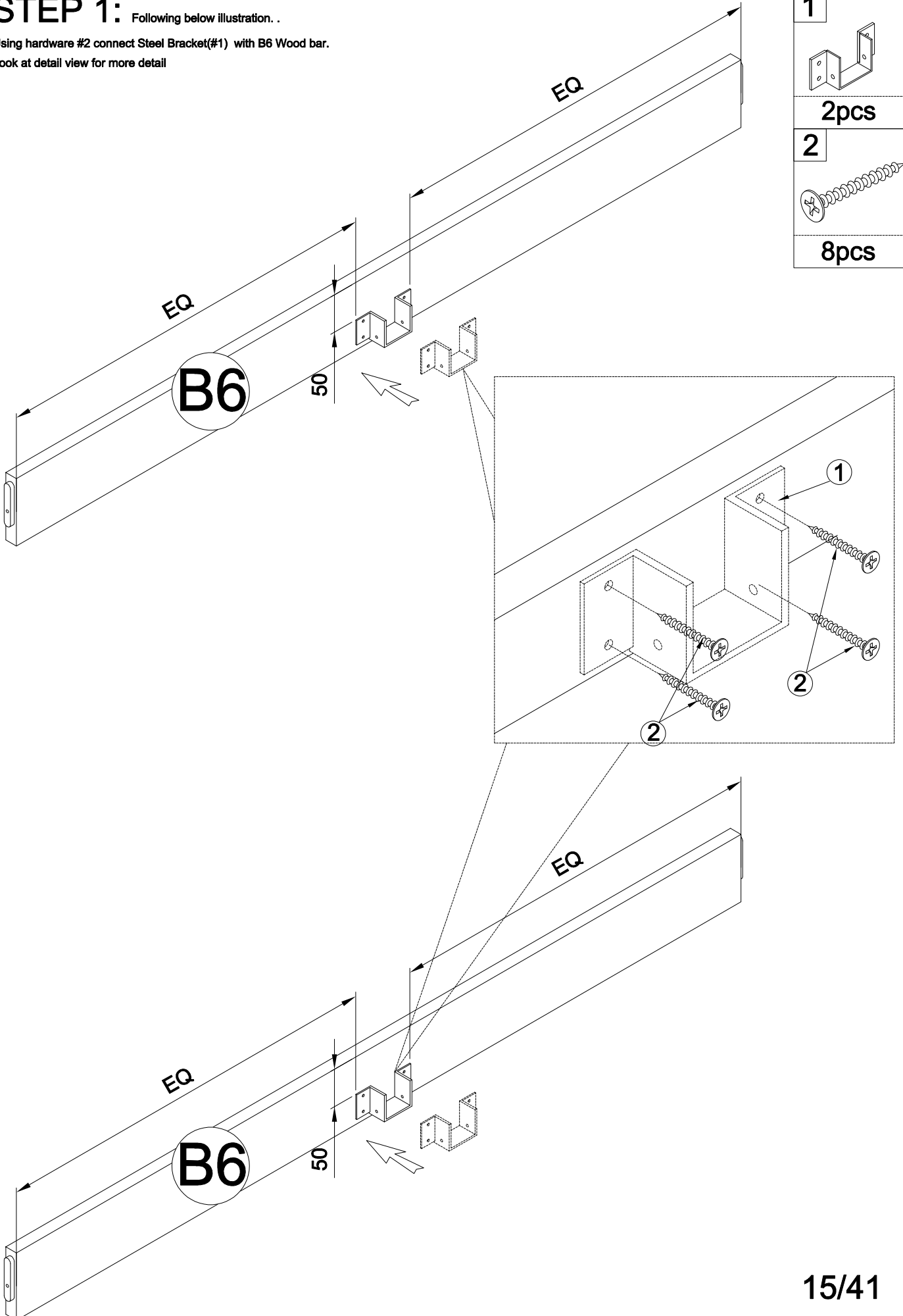

STEP 2: Following below illustration . .

2.1: Using hardware #3,#4 connect A1,A2 Legs with B1,B4,B5,B6,B7,B10 Wood bars and B3(x2) Panels.

2.2: Using hardware #5 connect Frame(completed on step 2.1) with B2 Wood bar

Look at detail view for more detail

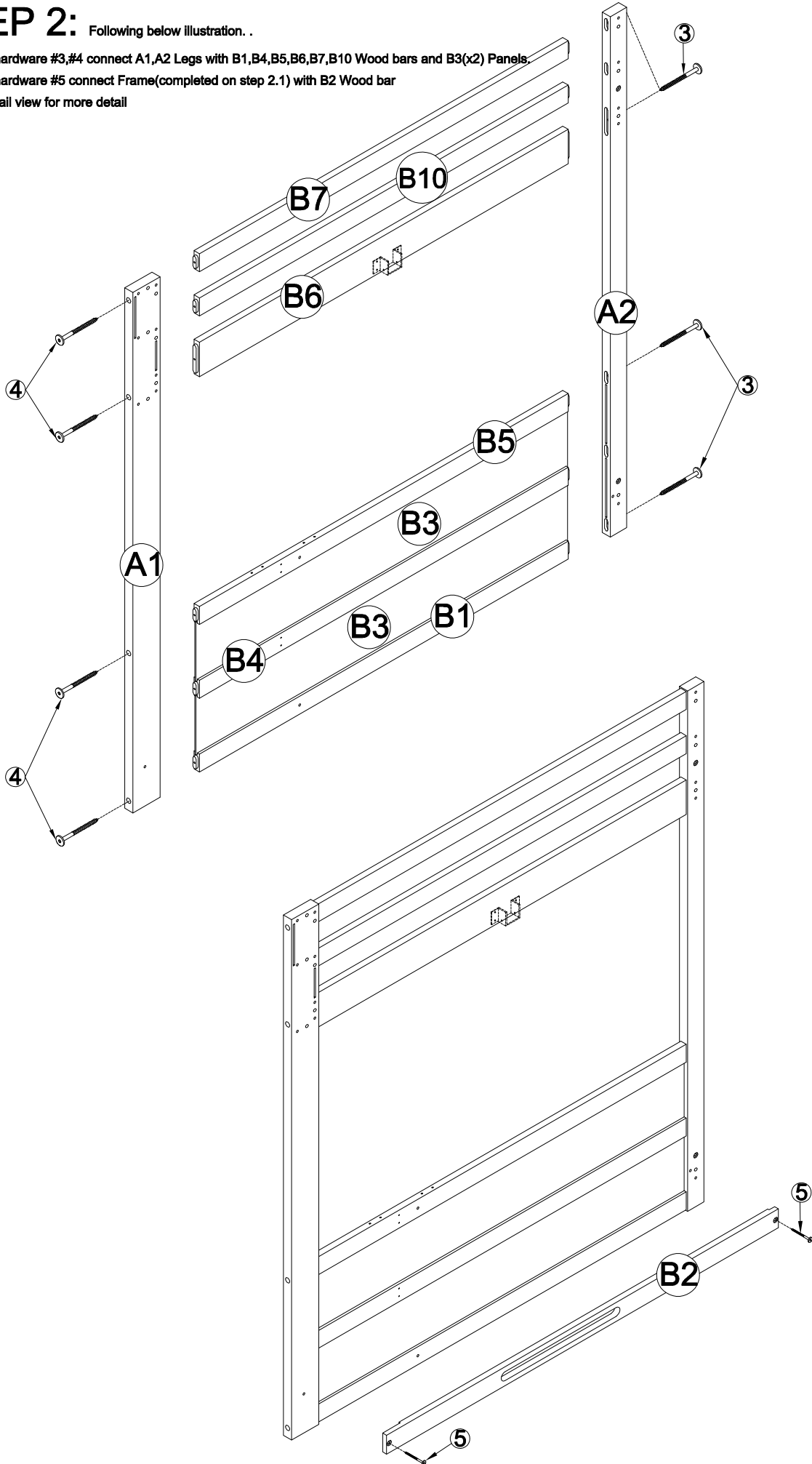

3

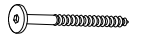

4pcs

4



4pcs

5

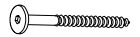

2pcs

STEP 3: Following below illustration. .

3.1: Using hardware #3,#4 connect A3,A4 Legs with B1,B8,B9,B6,B7,B10 Wood bars and B3(x2) Panels.

3.2: Using hardware #5 connect Frame(completed on step 3.1) with B2 Wood bar

Look at detail view for more detail

3



4pcs

4



4pcs

5



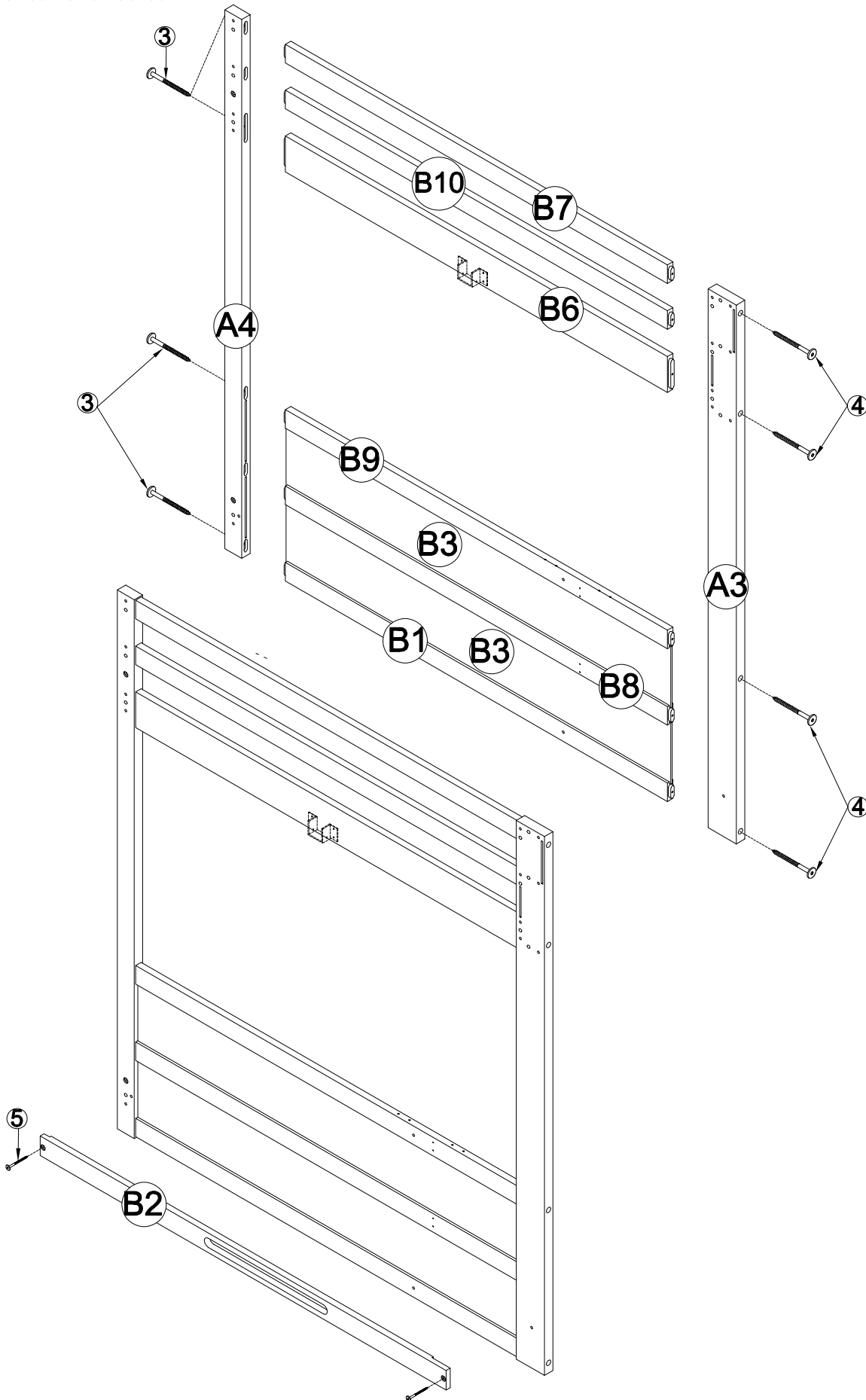

2pcs

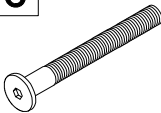

STEP 4-1: Following below illustration . .

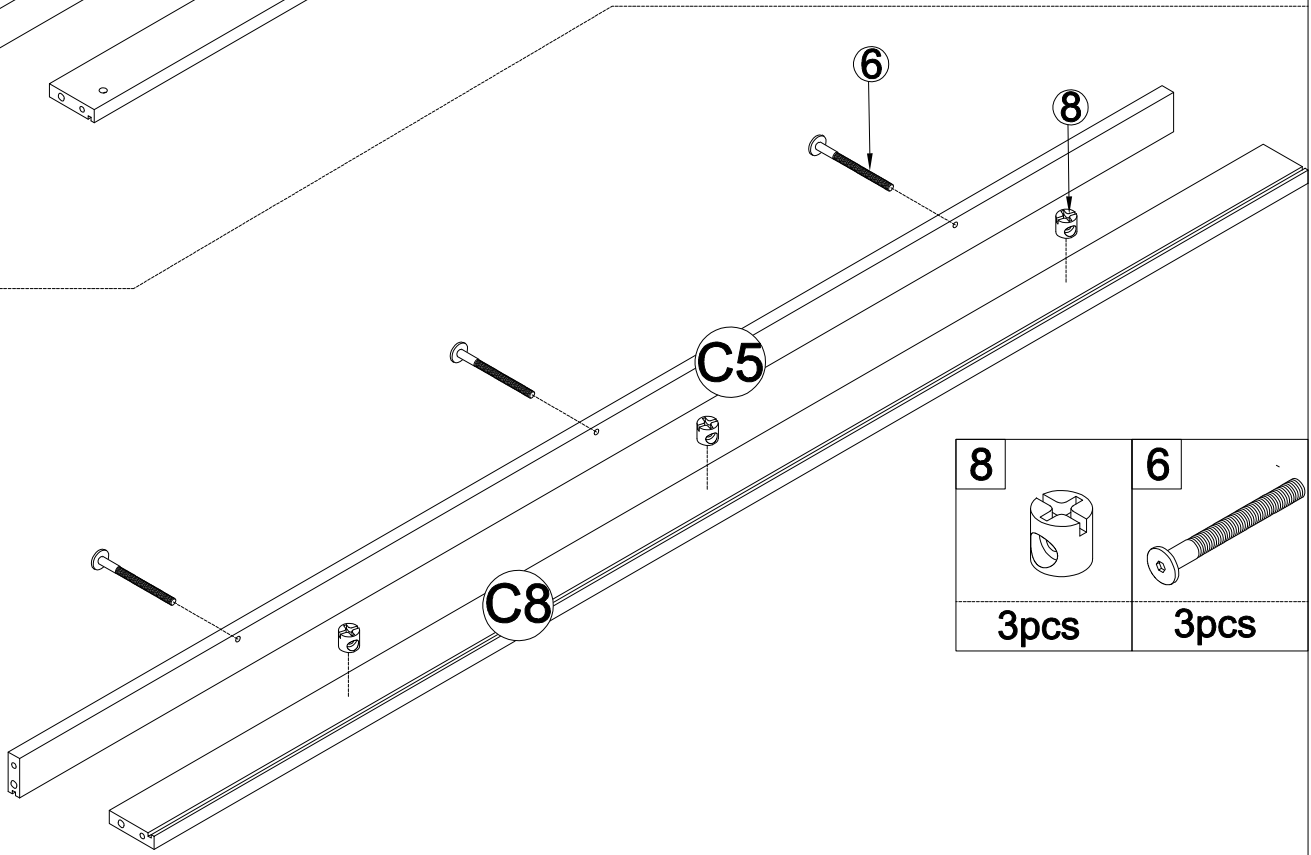
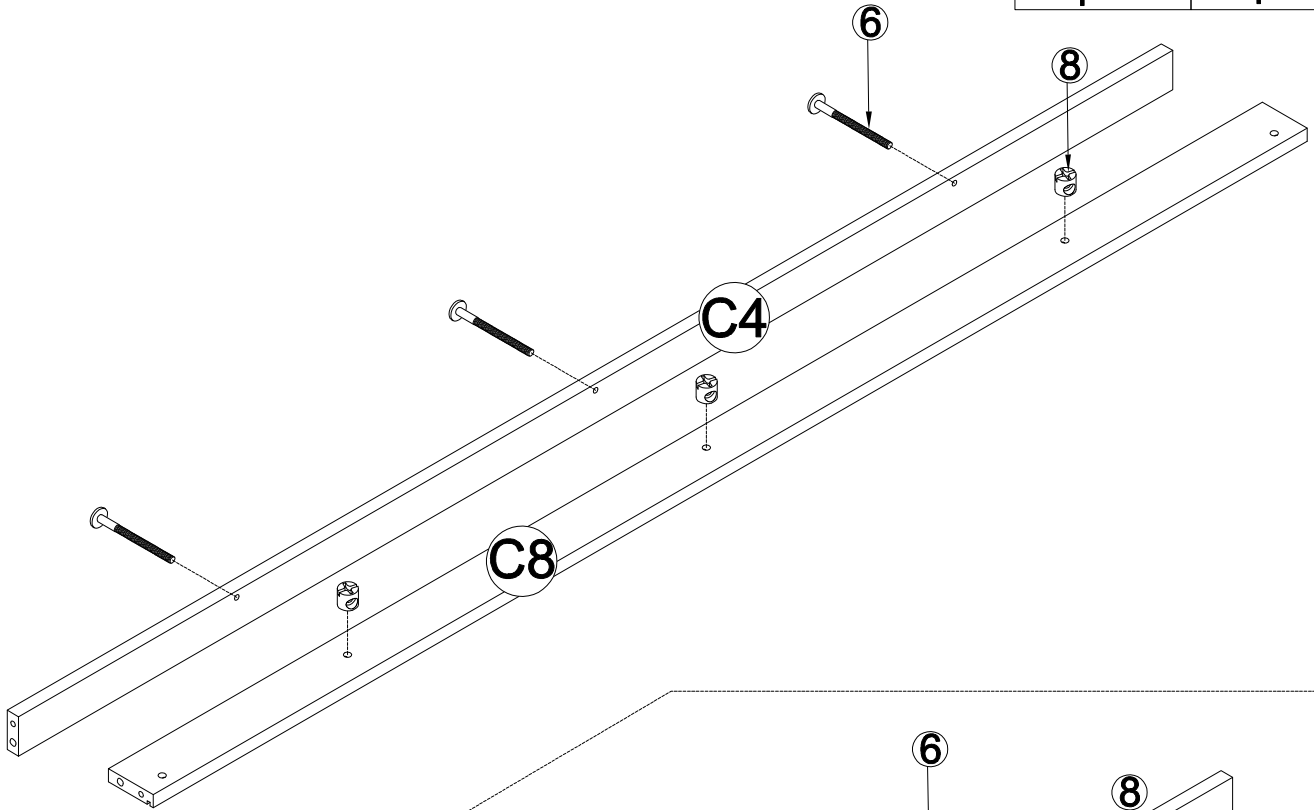
8		6	
3pcs		3pcs	

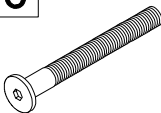

8		6	
3pcs		3pcs	

STEP 4-2: Following below illustration . .

STEP 4-3: Following below illustration..

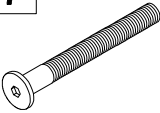
8		7	
3pcs		3pcs	

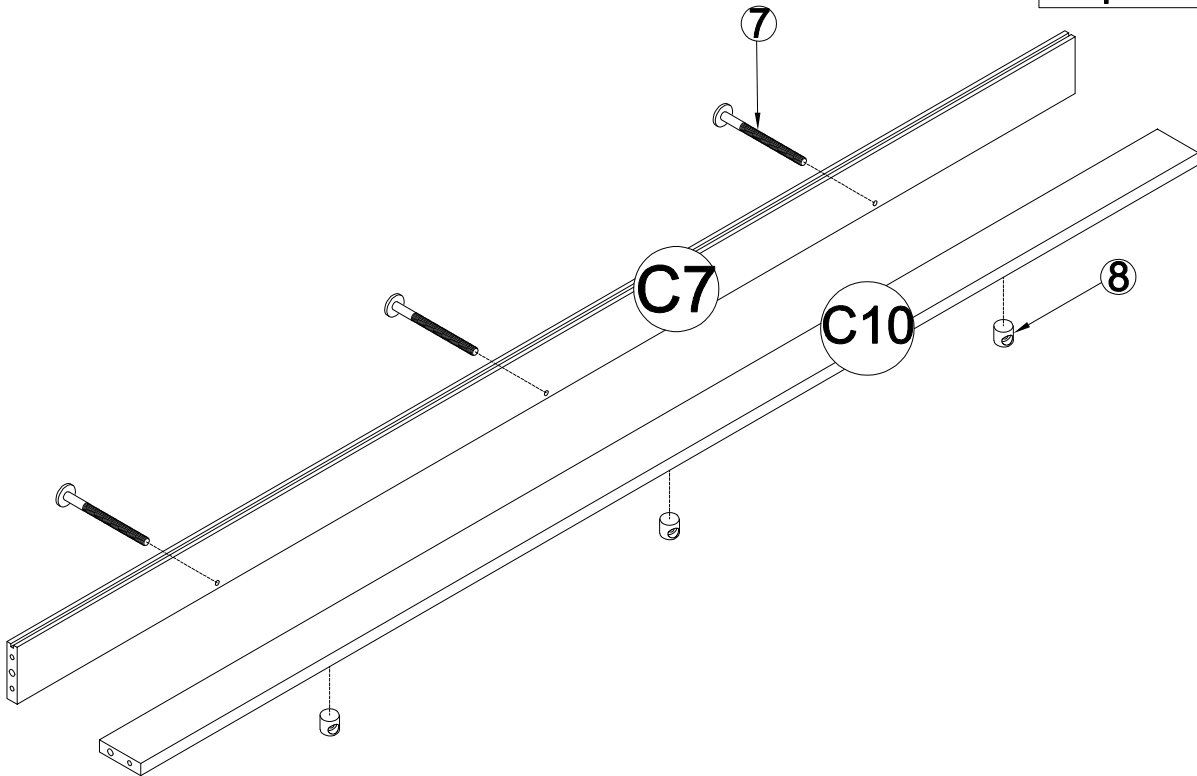

STEP 4-4: Following below illustration..

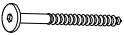
5	
3pcs	

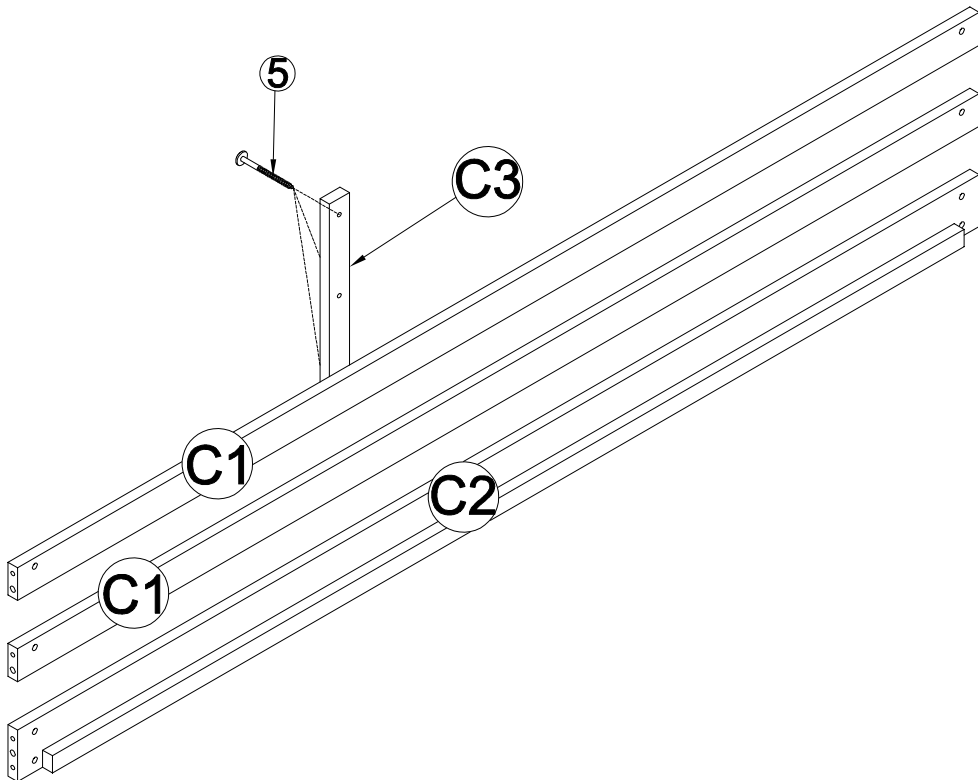

STEP 5-1: Following below illustration Using hardware #7,#8 and

dowel #9 to Assembly Frame (completd on step 2.2) with Frame (completd on step 4.1,Step 4.2,Step 4.3,Step 4.4),and C6,C9 Panels ,C11 Rail

Look at detail view for more detail

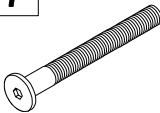
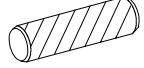
8		7	
12pcs		12pcs	
		9	
		10pcs	

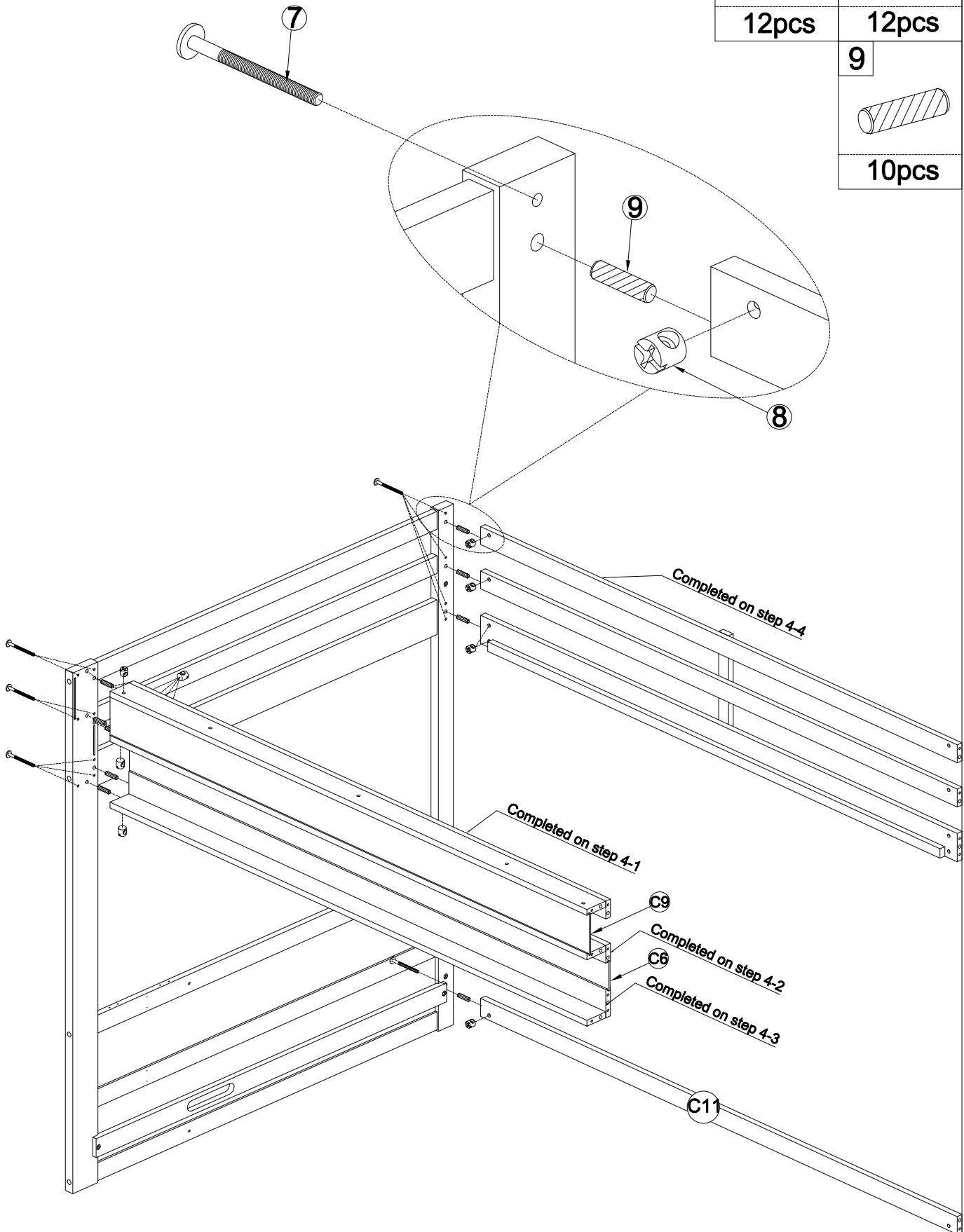

STEP 5-2: Following below illustration Using hardware #7,#8 and
 dowel #9 to Assembly Frame (completd on step 5.1) with Frame (completd on step 3.2).
 Look at detail view for more detail

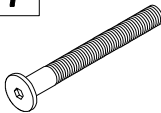
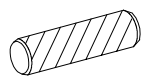
<p>8</p>  <p>12pcs</p>	<p>7</p>  <p>12pcs</p>
<p>9</p>  <p>10pcs</p>	

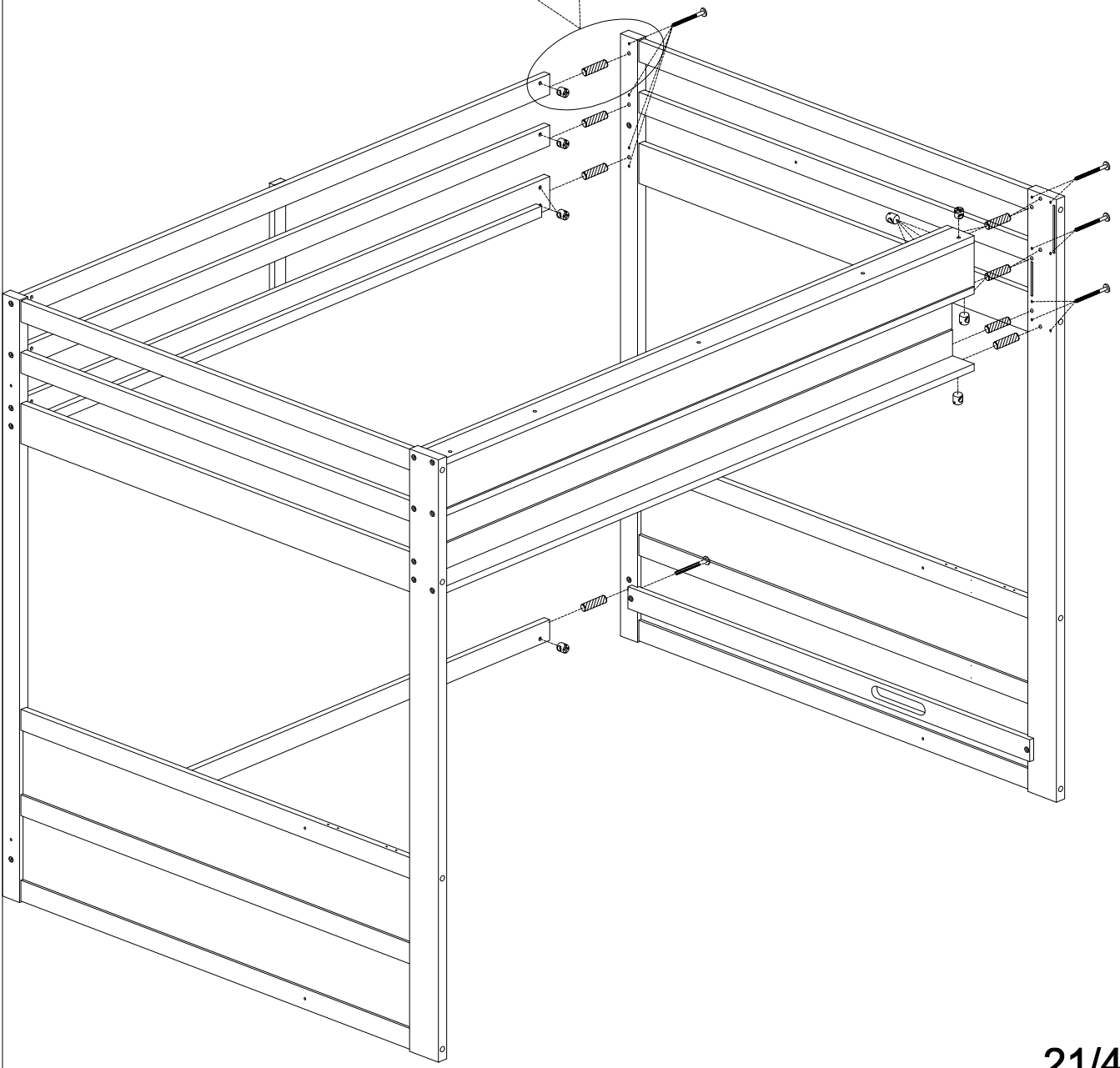
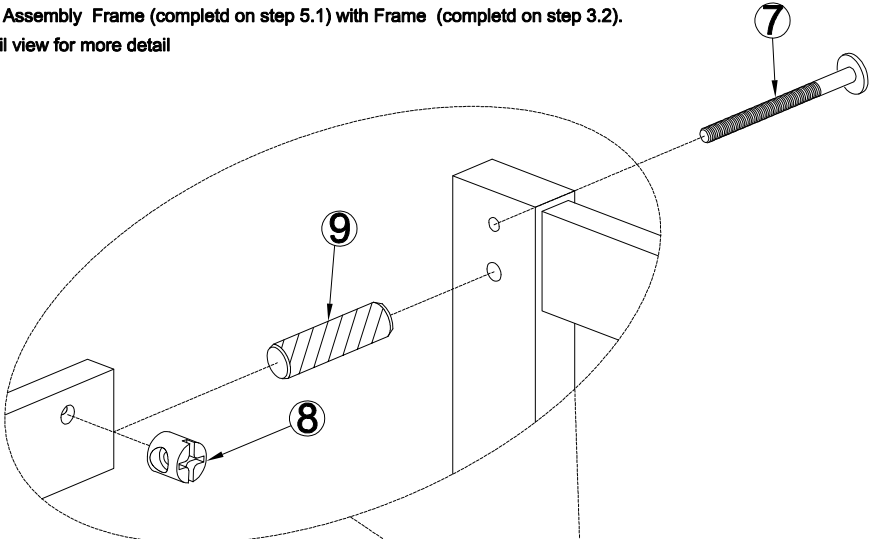

STEP 6: Following below illustration:

- Put Support Slats D2 on position
- Screw 14 slats D1 with Side Rail C1,C7 by using hardward #8.
- Look at detail view for more detail

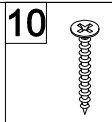

28 pcs

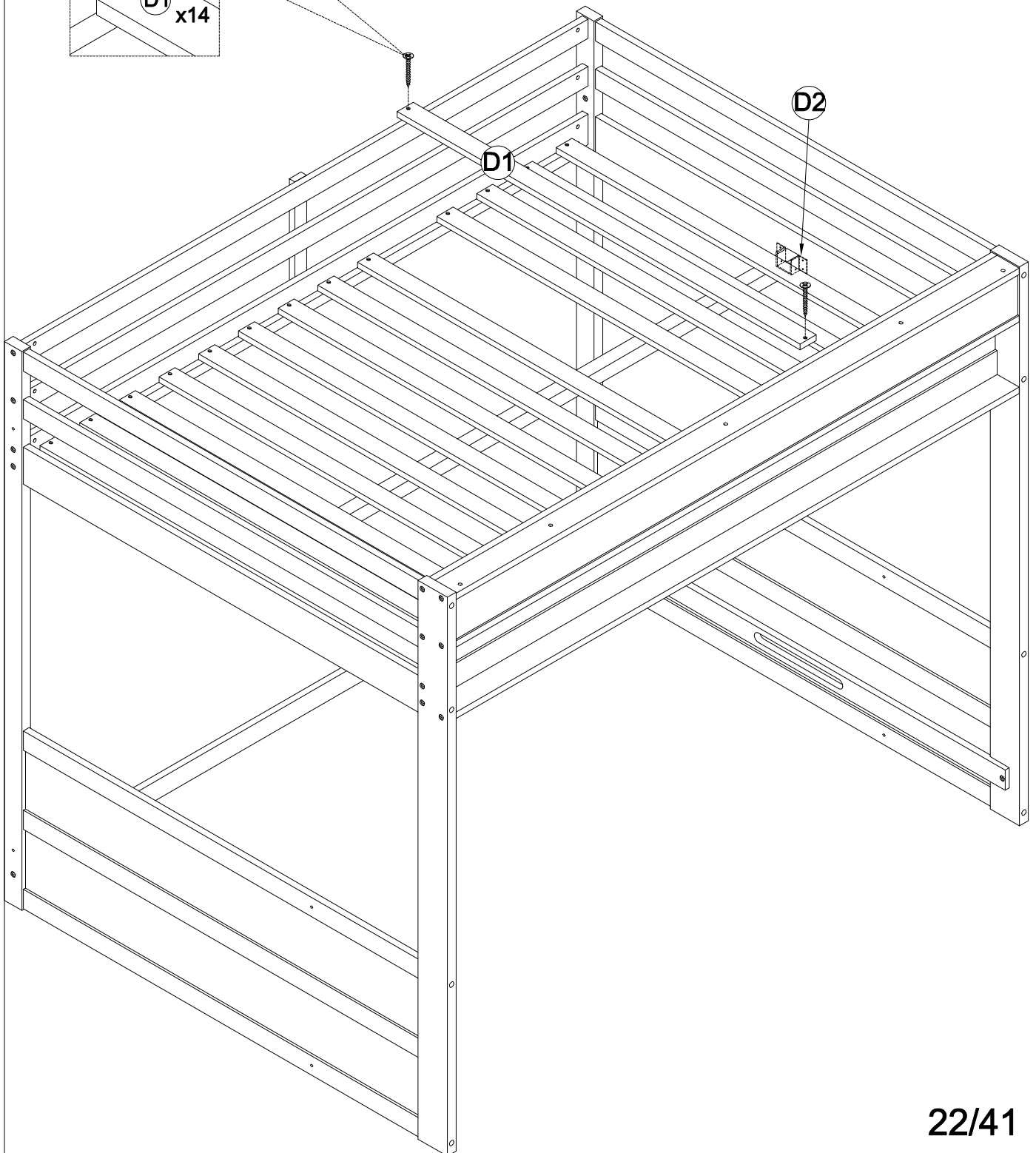
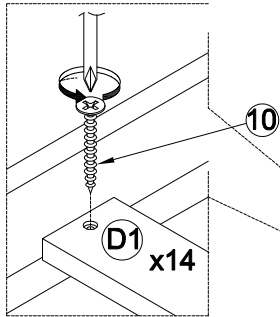

STEP 7-1: Following below illustration:

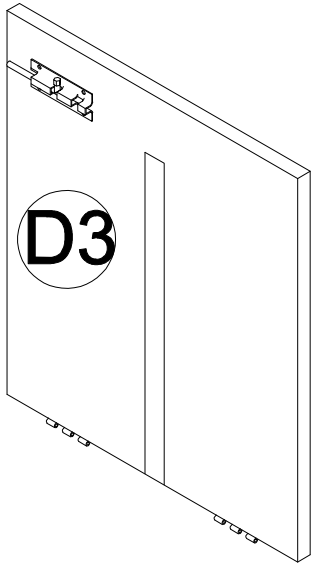

OPTION 2,4

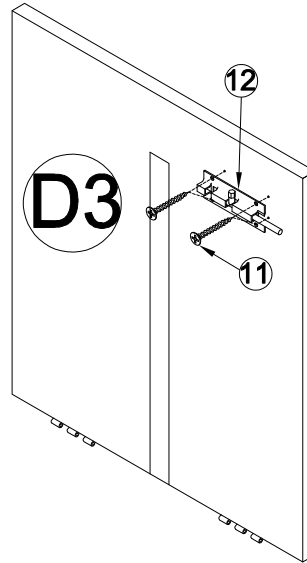

OPTION 1,3

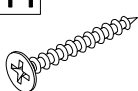
12 	11 
1pc	4pcs

STEP 7-2: Following below illustration:

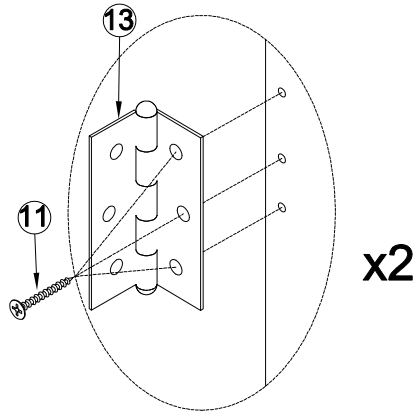

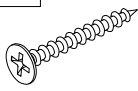
13 	11 
2pcs	6pcs

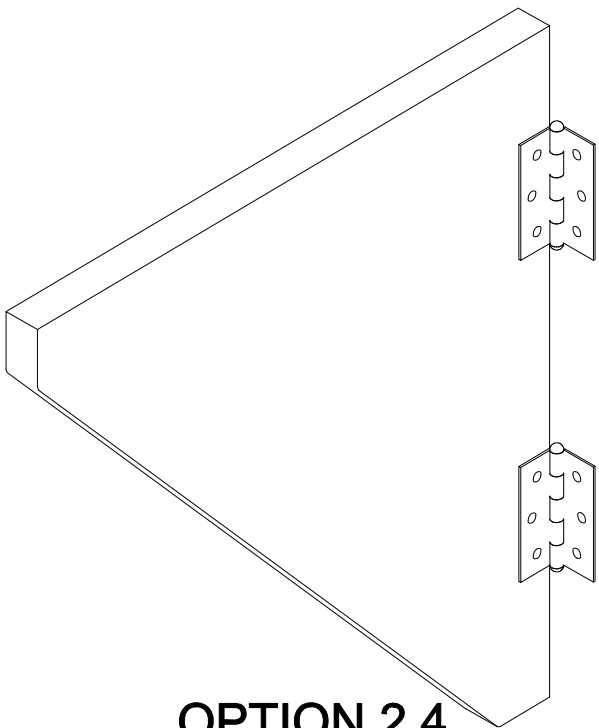

OPTION 2,4

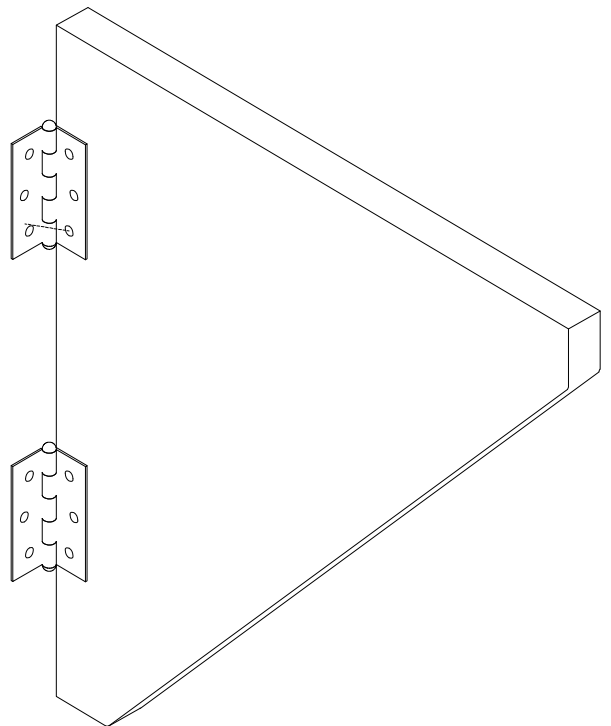

OPTION 1,3

STEP 7-3: Following below illustration:

11

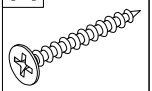

6pcs

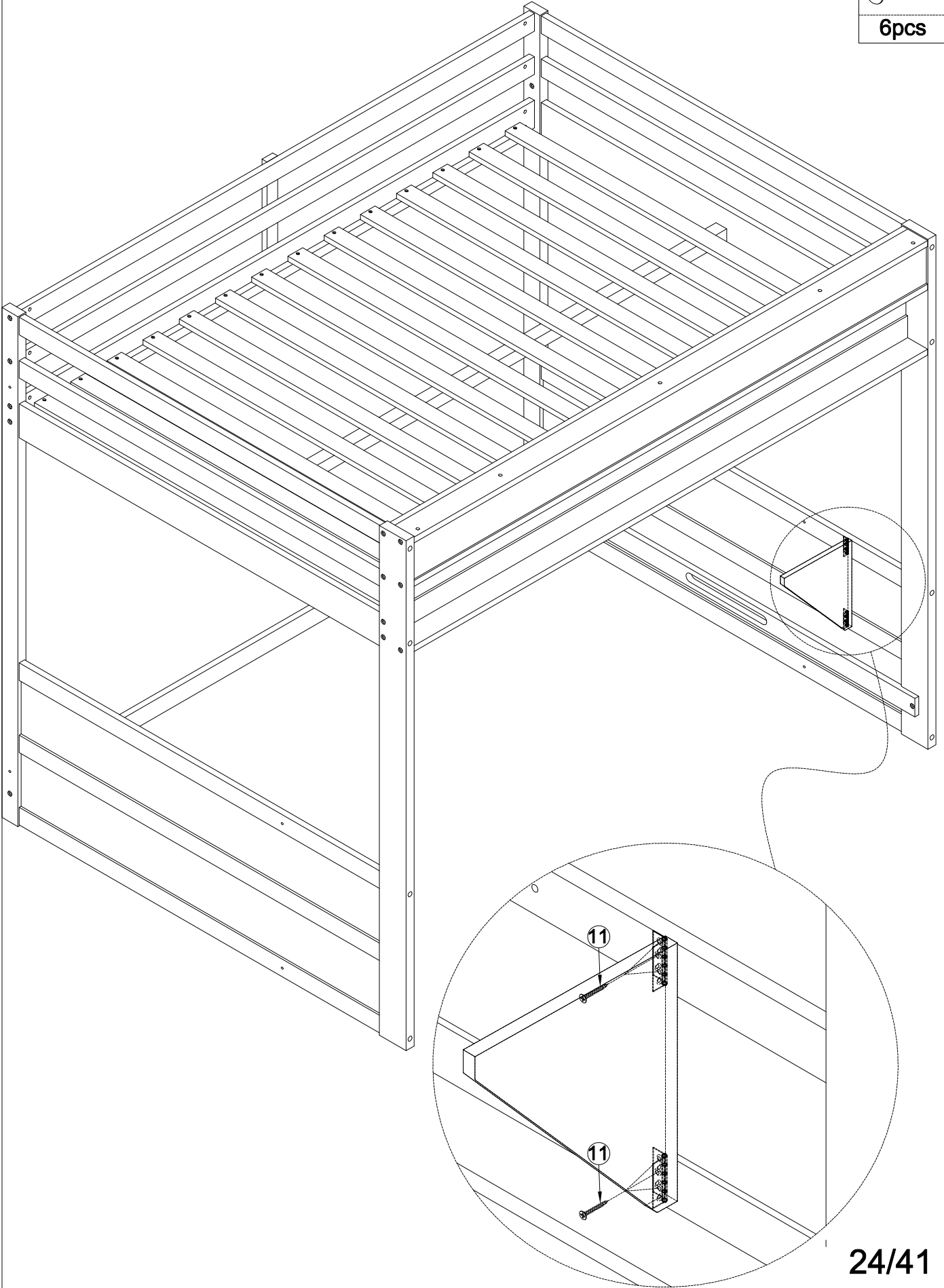

STEP 7-4: Following below illustration:

11

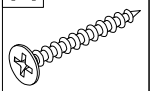

6pcs

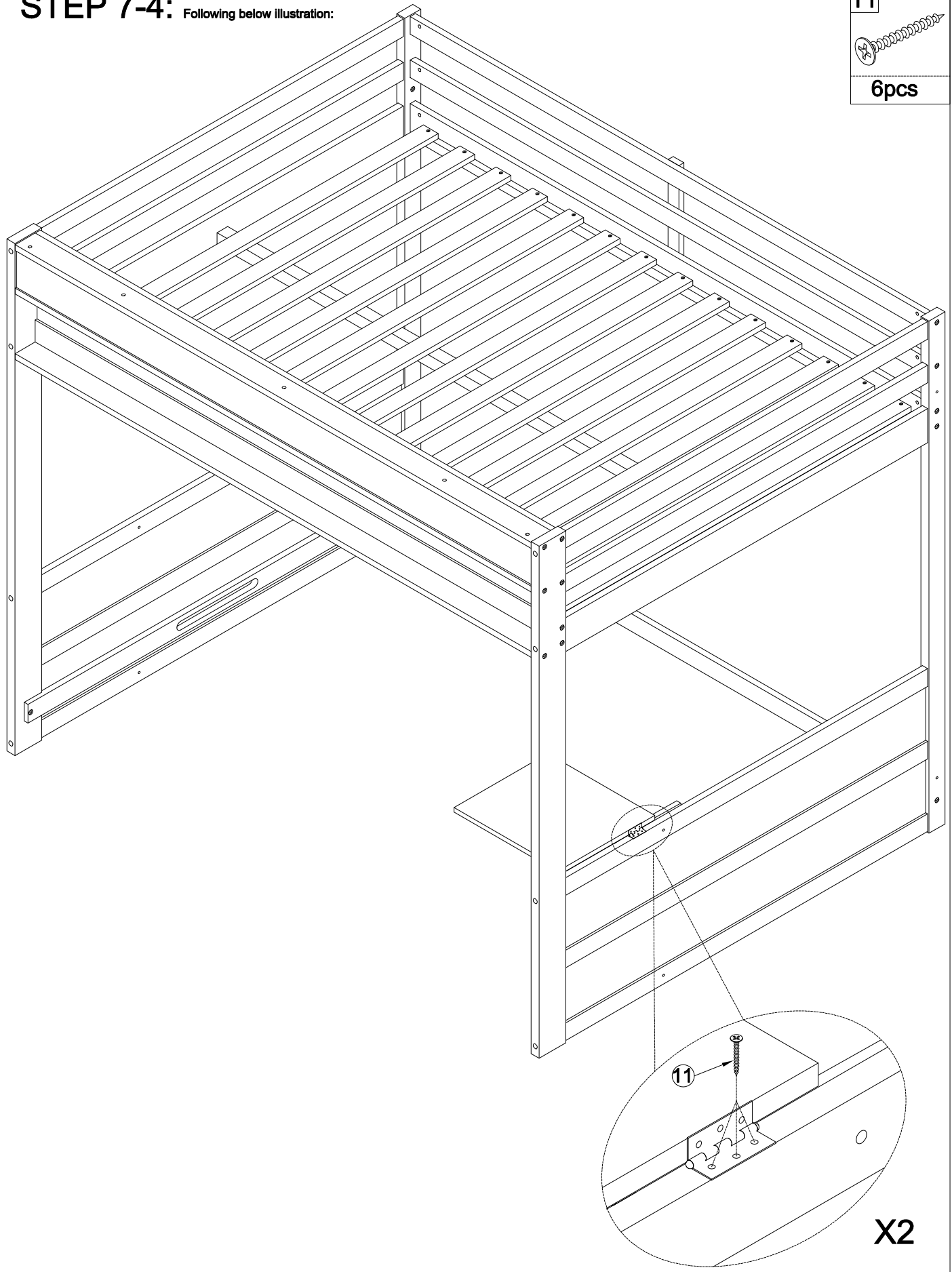

X2

STEP 8-1: Following below illustration:

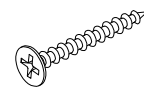
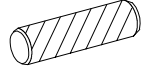
2	14
	
4pcs	2pcs

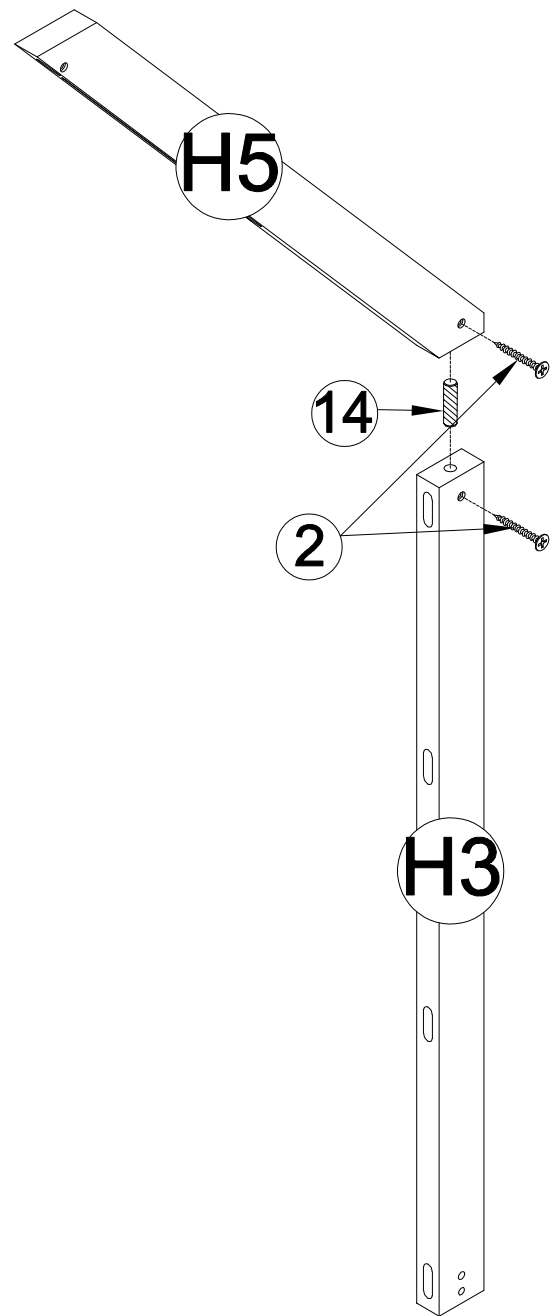
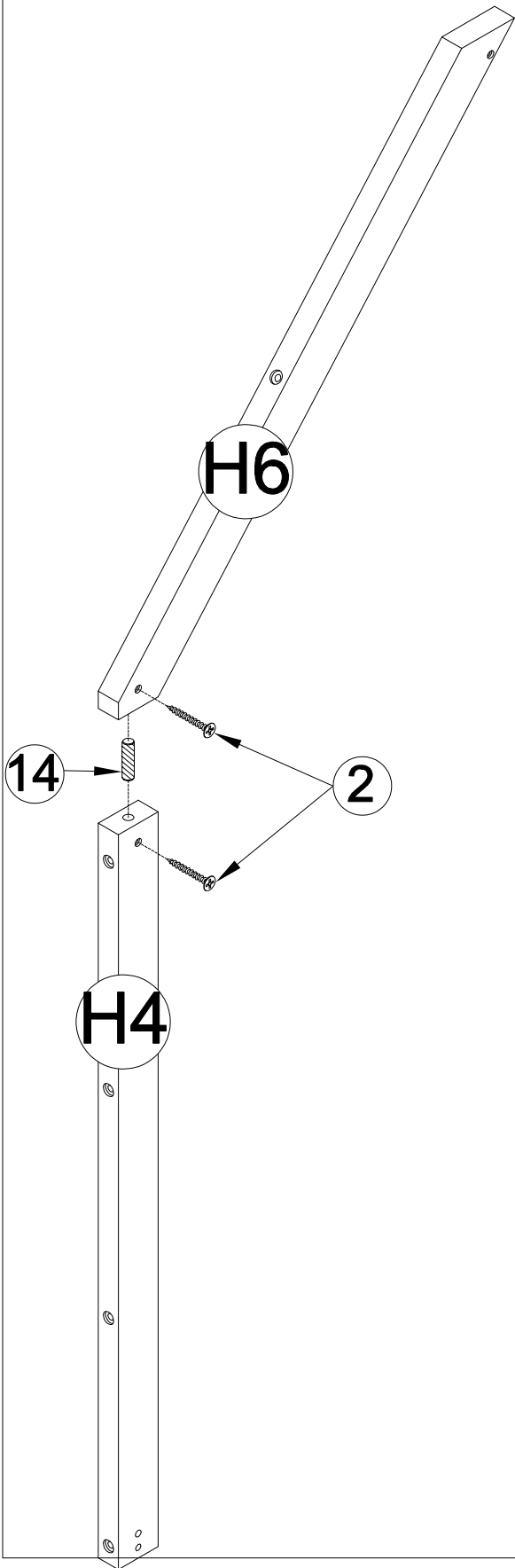

STEP 8-2: Following below illustration:

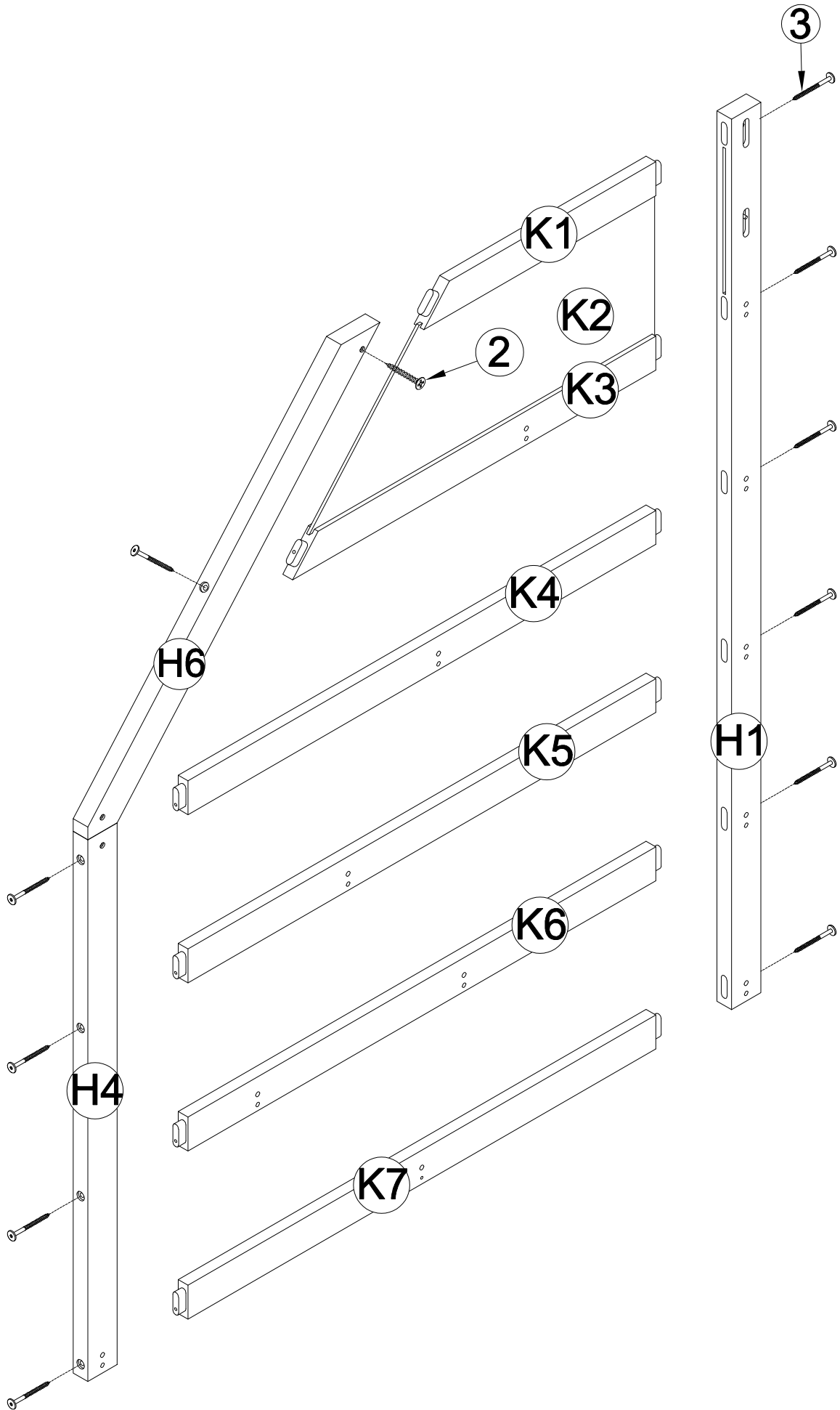

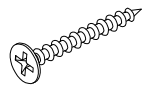
3	
11pcs	
2	
1pc	

STEP 8-3: Following below illustration:

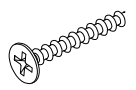

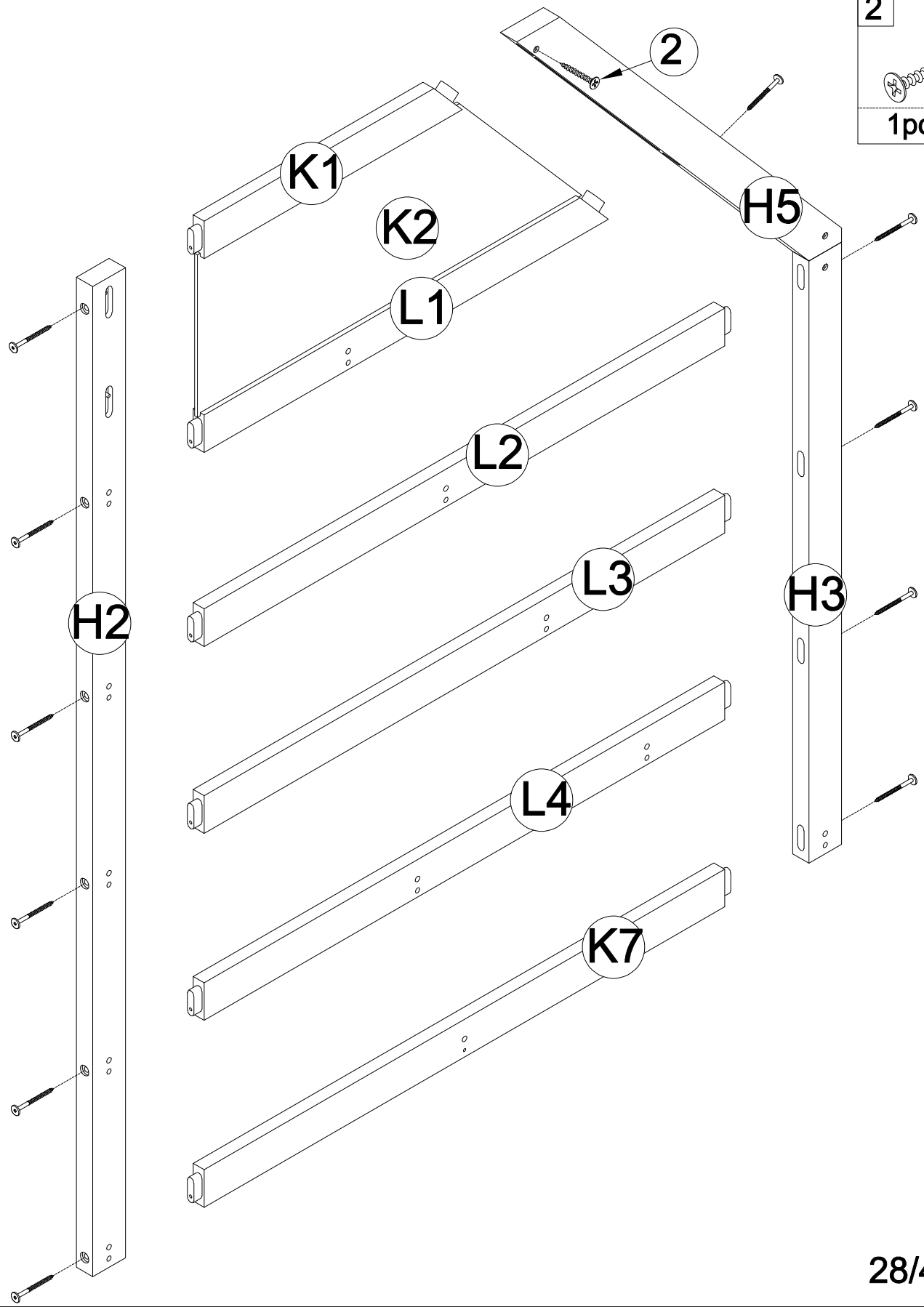
3	
11pcs	
2	
1pc	

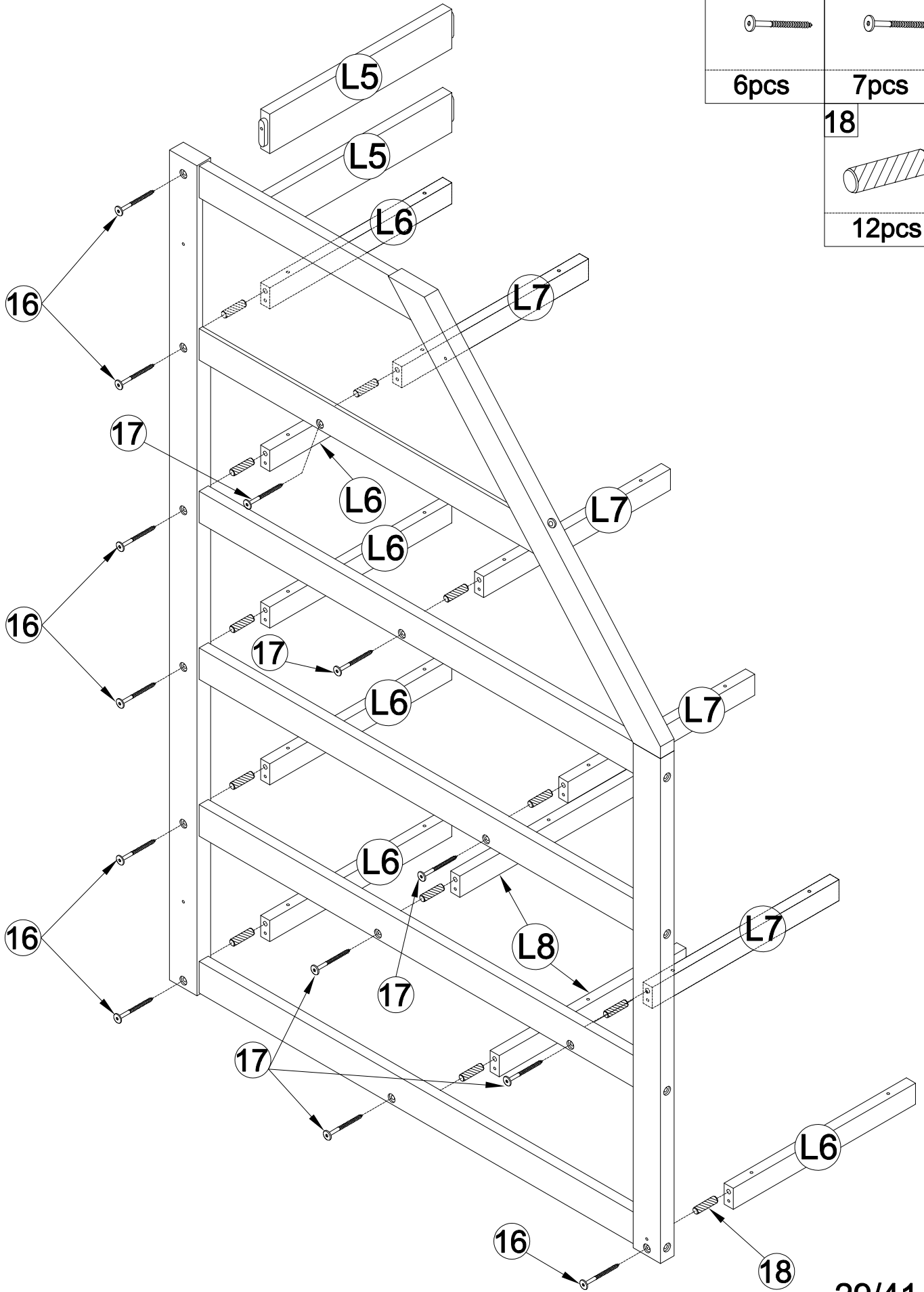

STEP 8-4: Following below illustration:

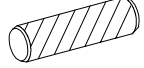

STEP 8-5: Following below illustration:

17 	16 
6pcs	7pcs
	18 
	12pcs

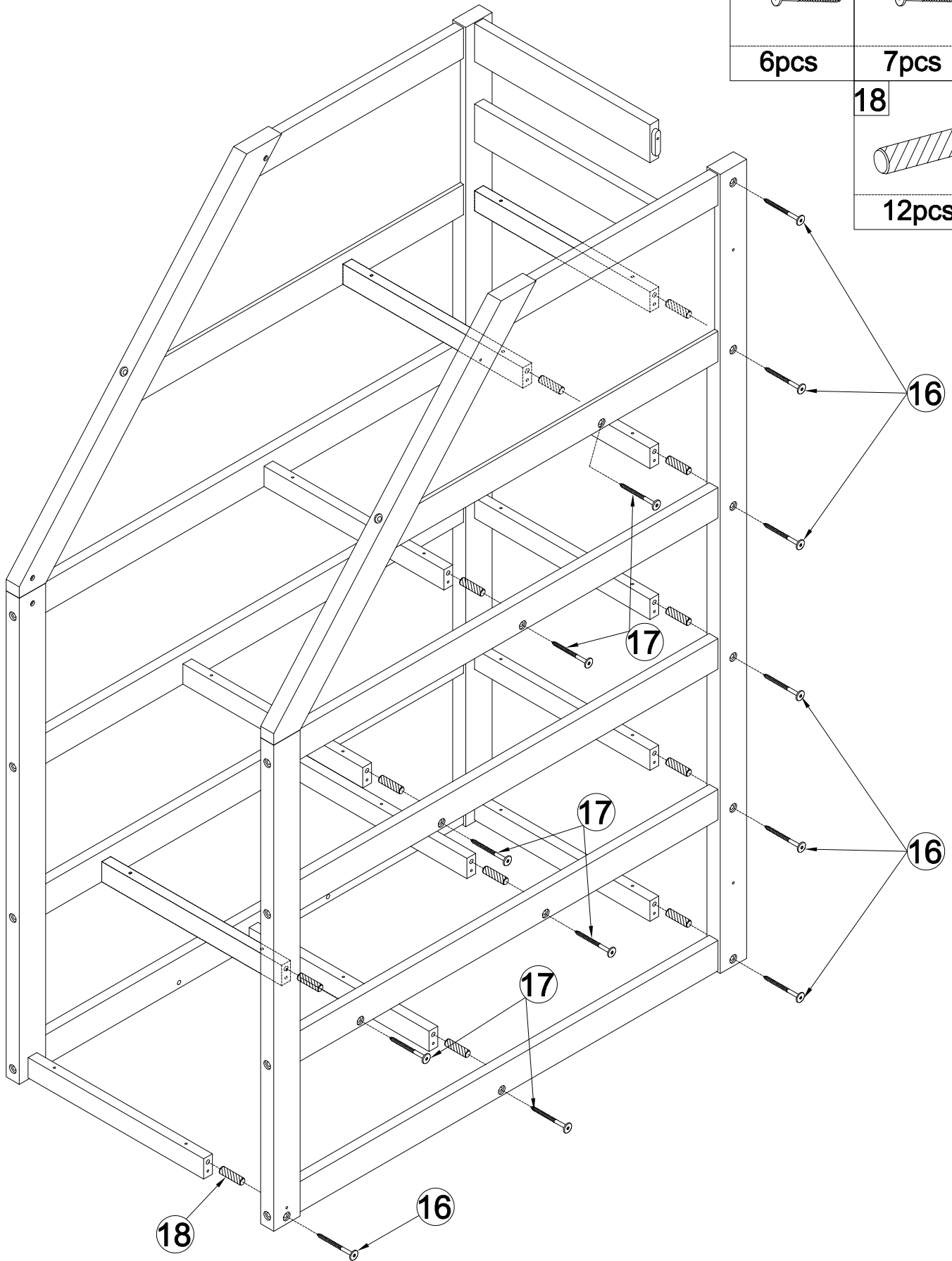

STEP 8-6: Following below illustration:

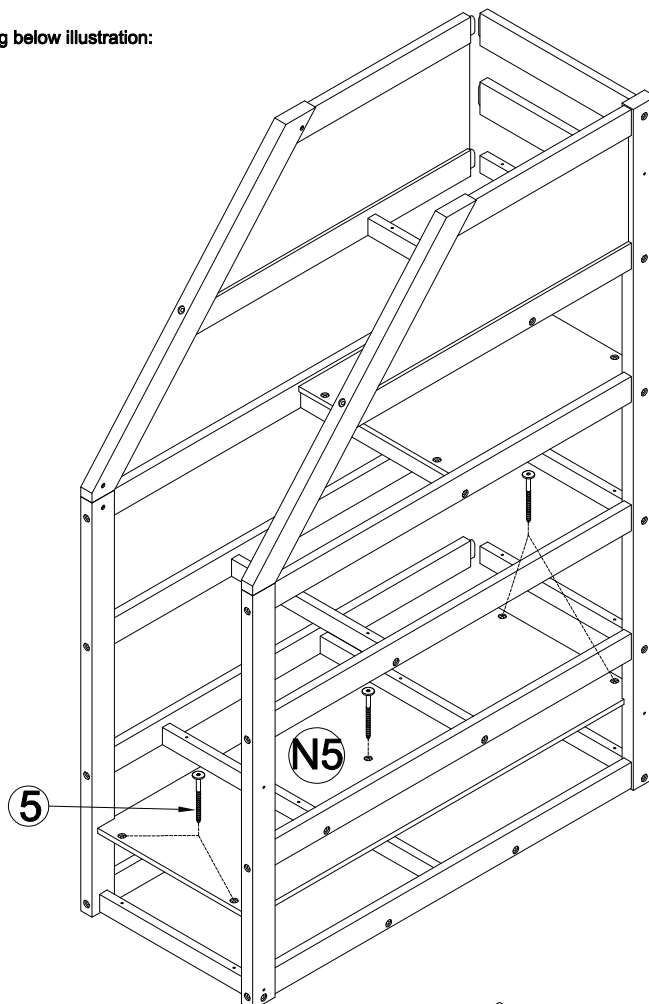

5



5pcs

STEP 8-7: Following below illustration:

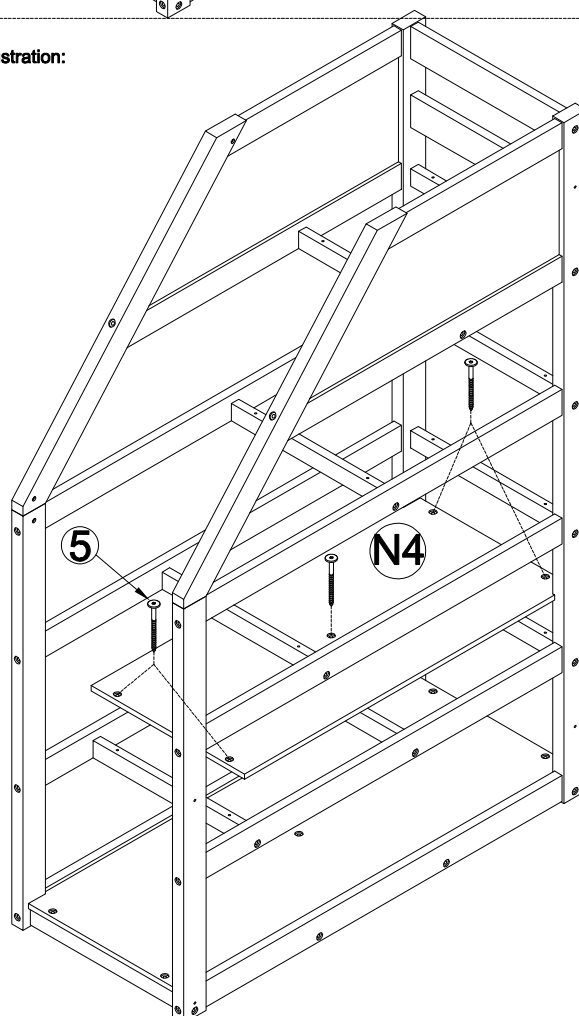

5

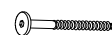

5pcs

STEP 8-8: Following below illustration:

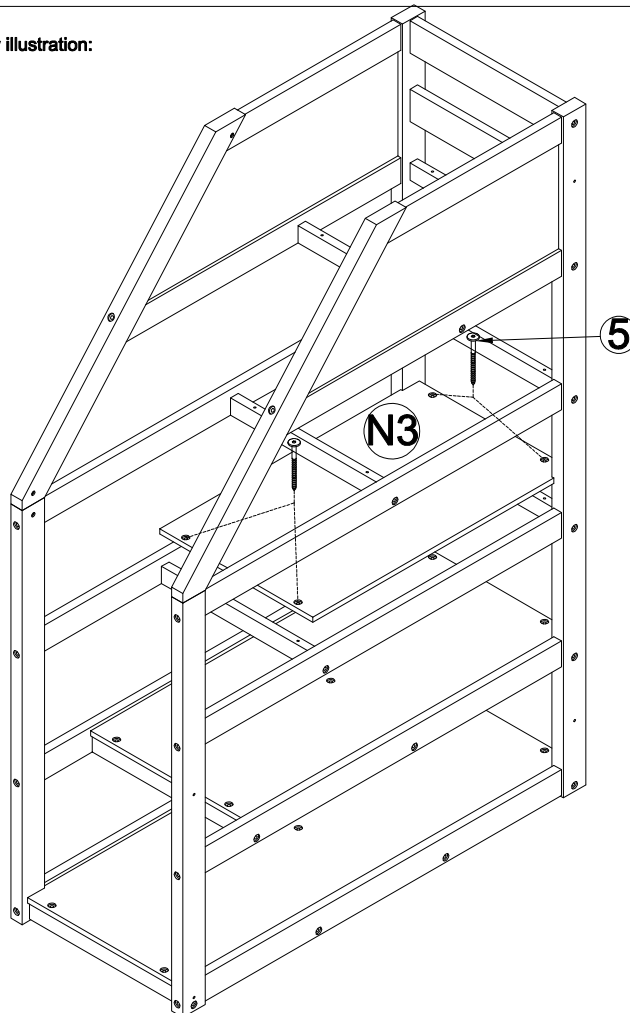

5



4pcs

STEP 8-9: Following below illustration:

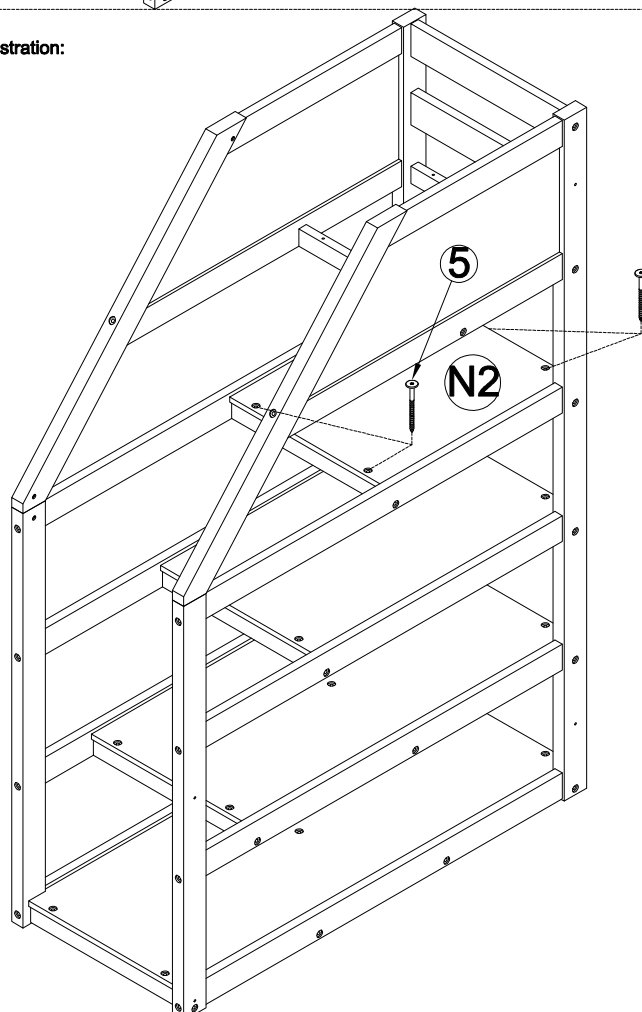

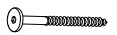

5



4pcs

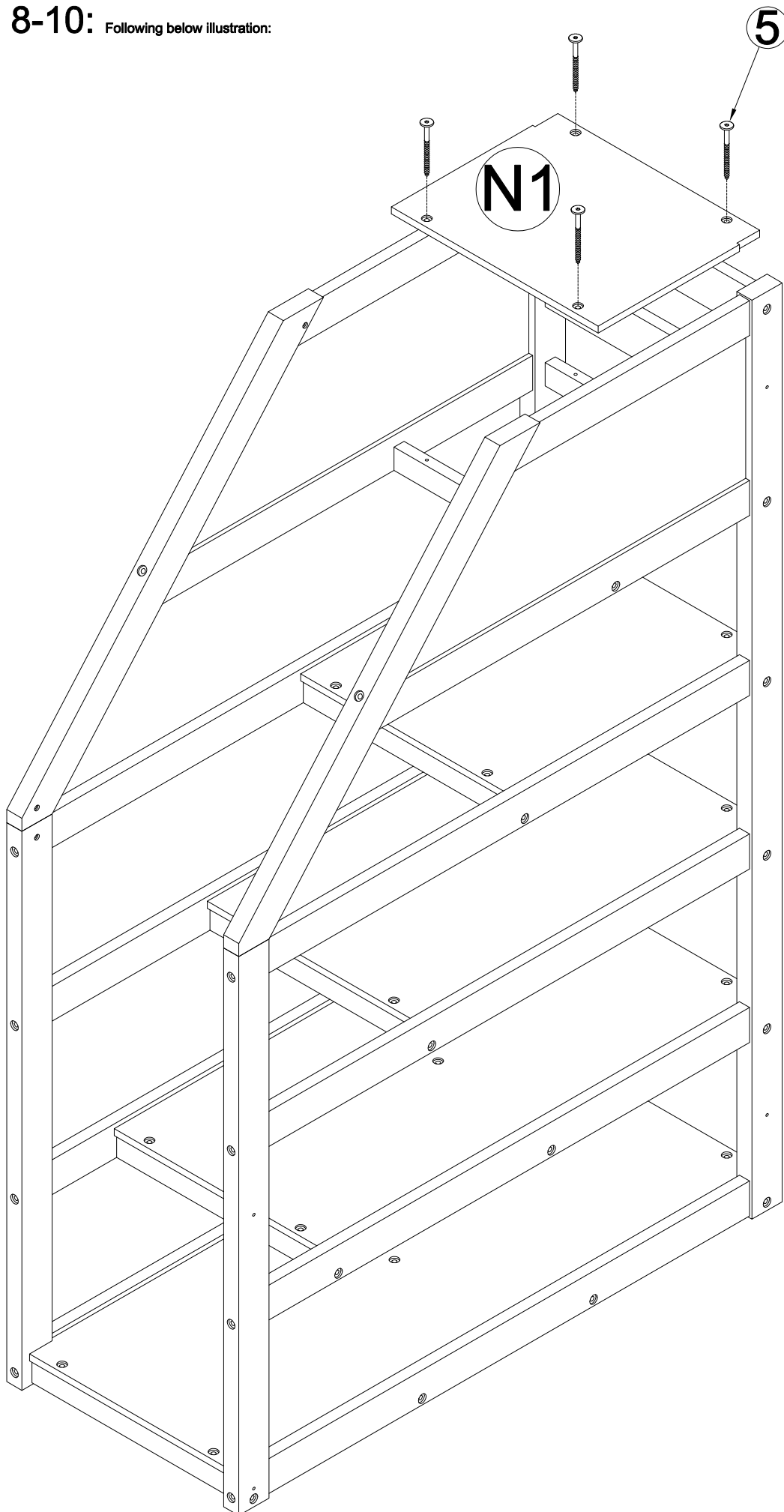

STEP 8-10: Following below illustration:



5

4pcs

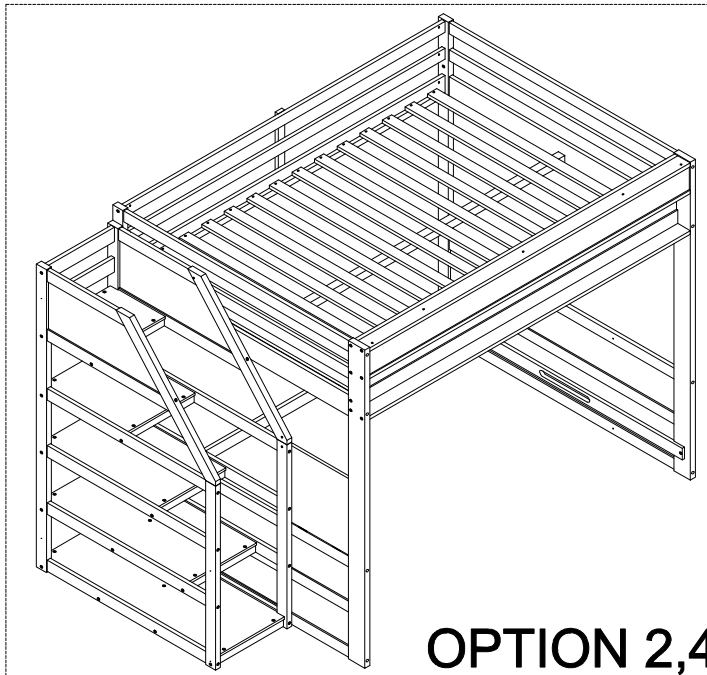
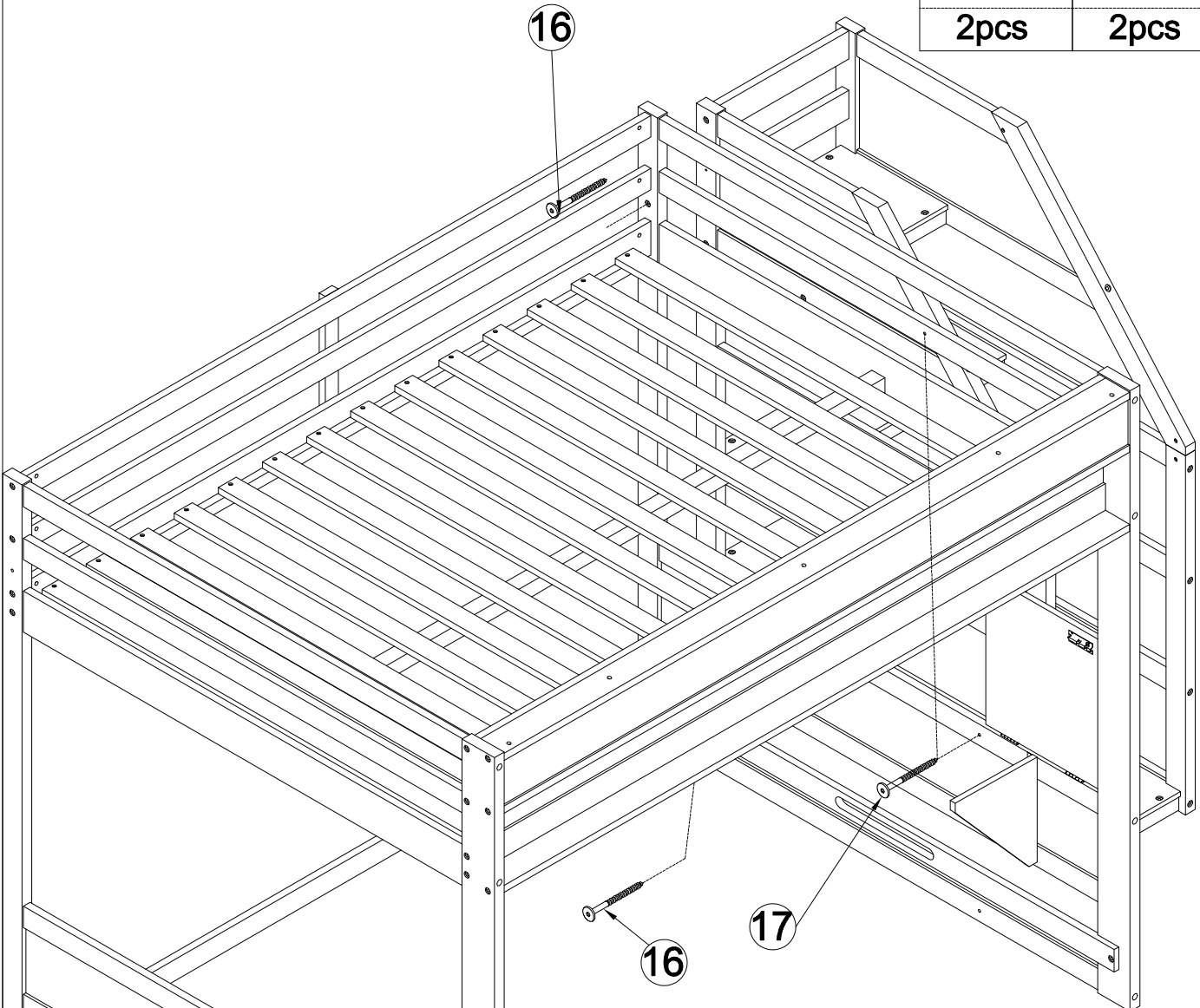

STEP 9: Following below illustration . .

-Using hardware #16,#17 connect Frame(completed on step 7-4) with Frame(completed on step 8-8)
Look at detail view for more detail

16	17
	
2pcs	2pcs

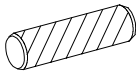

STEP 10-1:

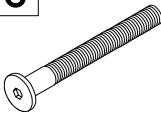
9	8	6
		
4pcs	8pcs	8pcs

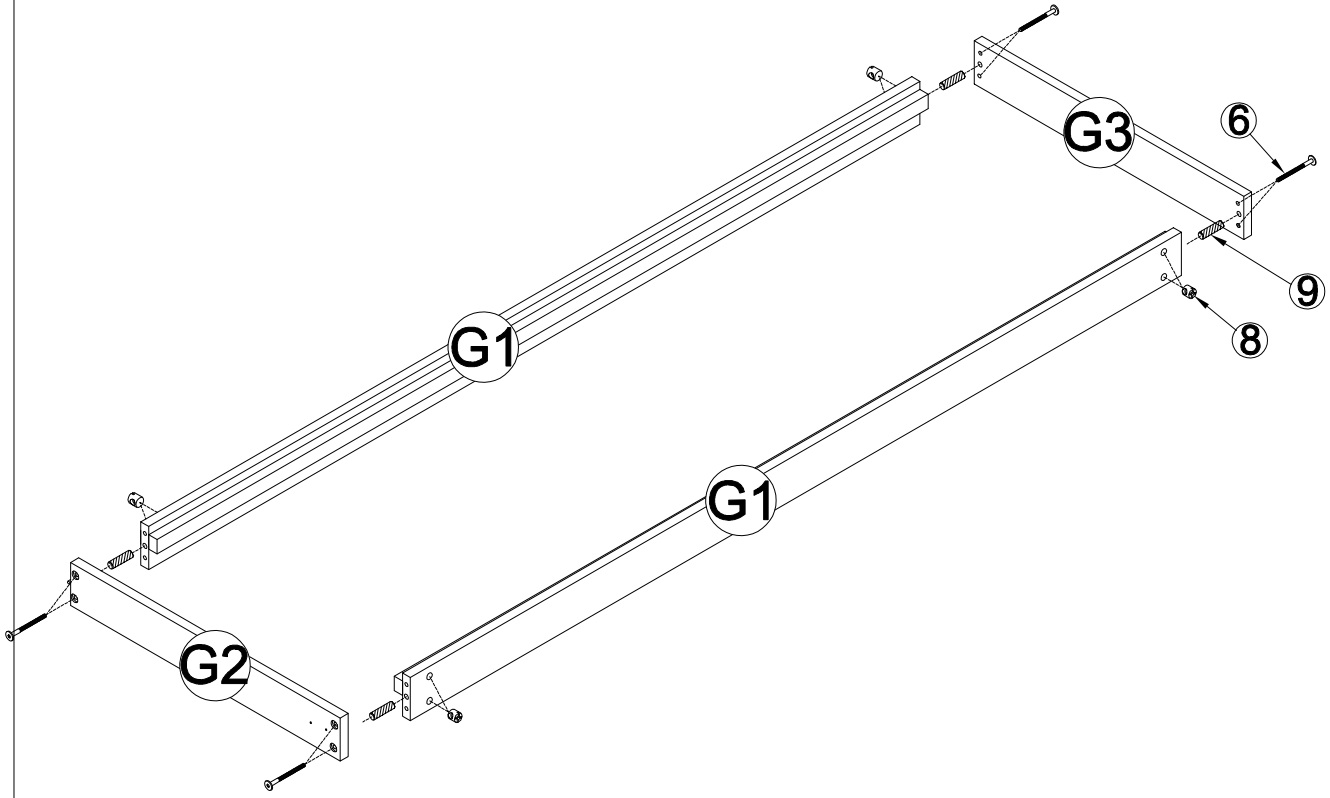



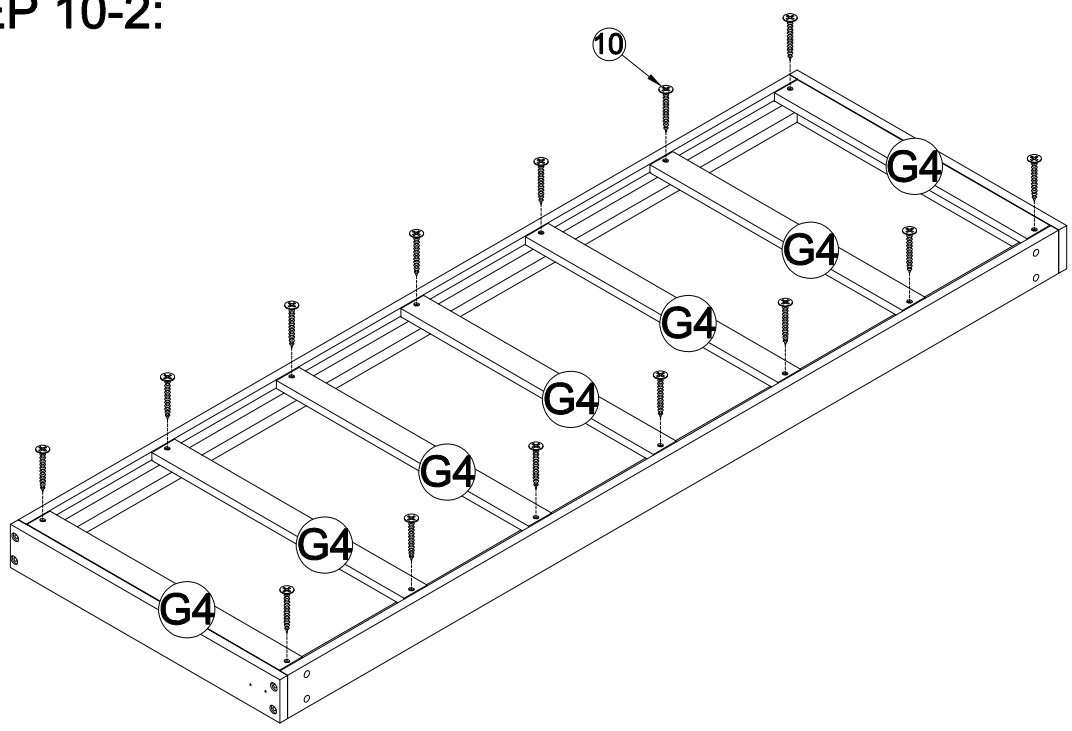

STEP 10-2:

10	
14 pcs	

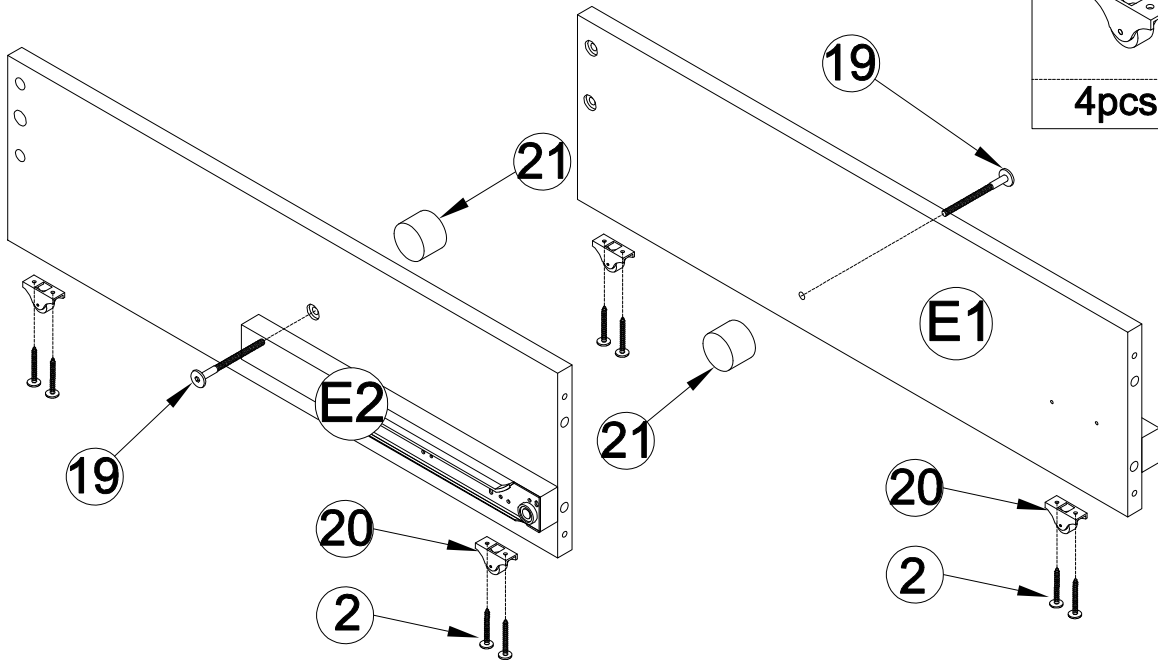



STEP 10-3:



20	2
	
4pcs	8pcs
19	
	2pcs
21	
	2pcs

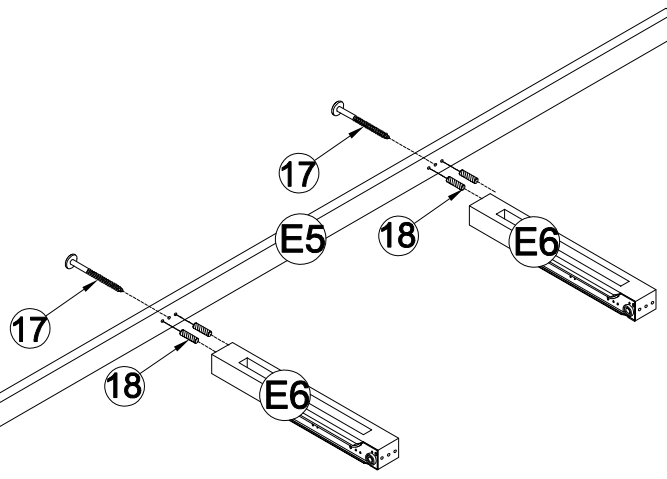

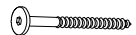
STEP 10-4:

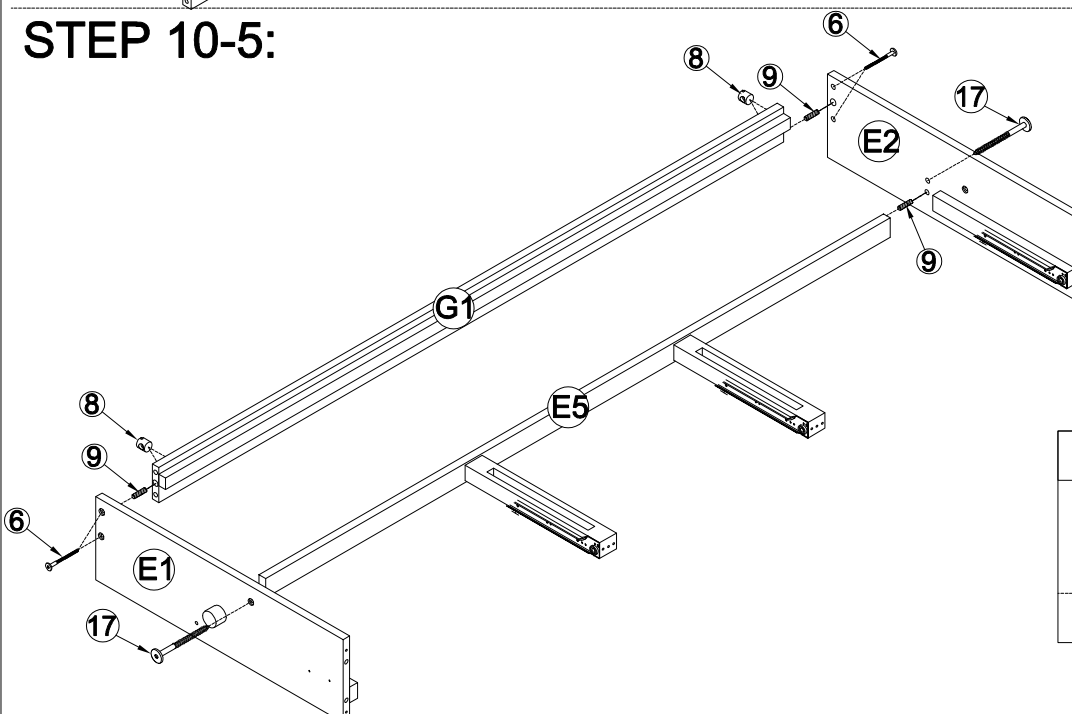

17	
	2pcs
18	
	4pcs

STEP 10-5:

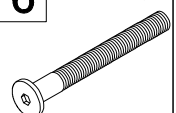
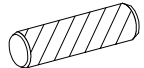

6	
	4pcs
9	
	4pcs
8	
4pcs	17
	
	2pcs

STEP 10-6:

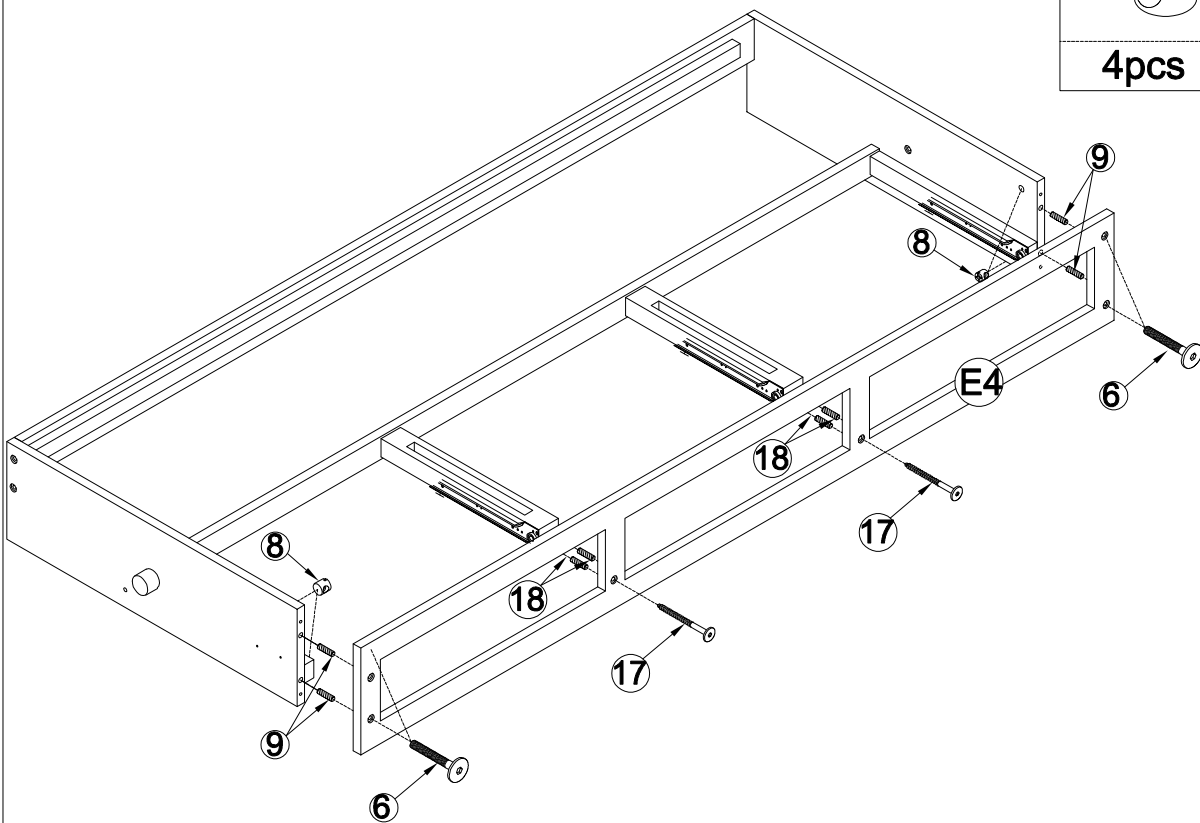

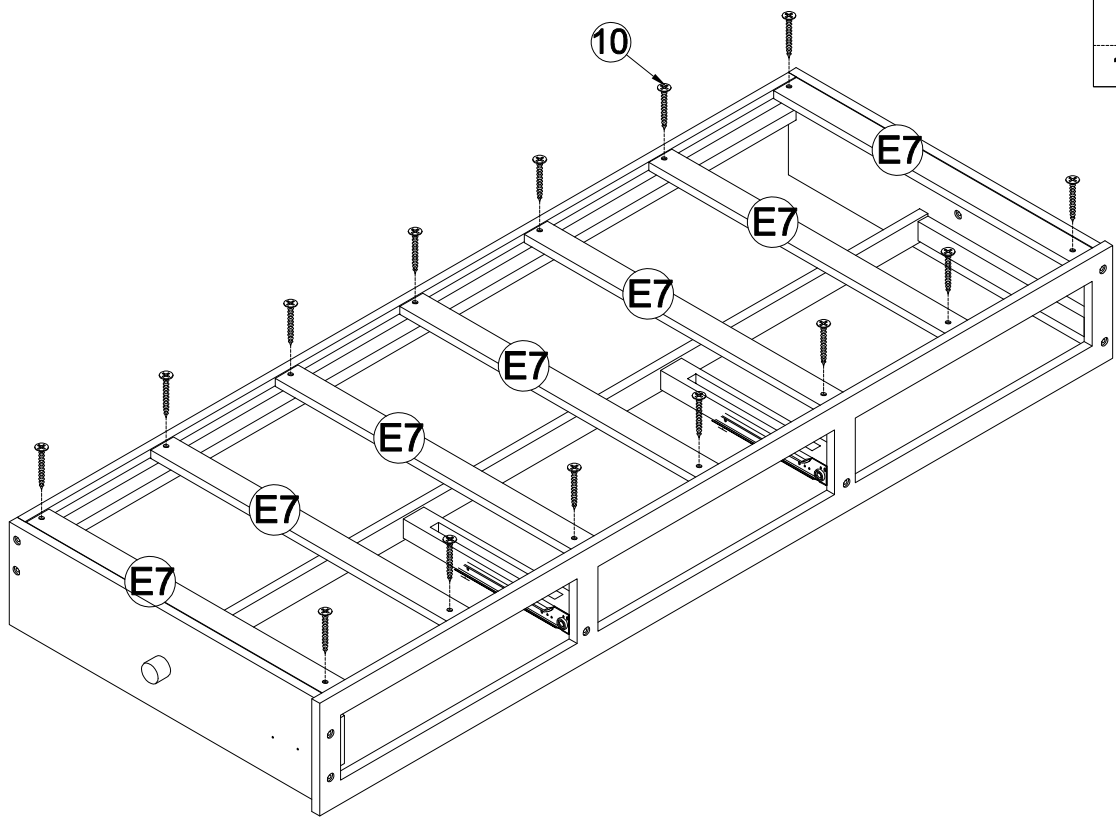

8		6	
4pcs		4pcs	
9		17	
4pcs		2pcs	
18		18	
4pcs			

STEP 10-7:

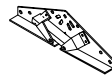

10	
14 pcs	

STEP 10-8:

2		22	
8x2pcs		1pc	
		23	
		1pc	

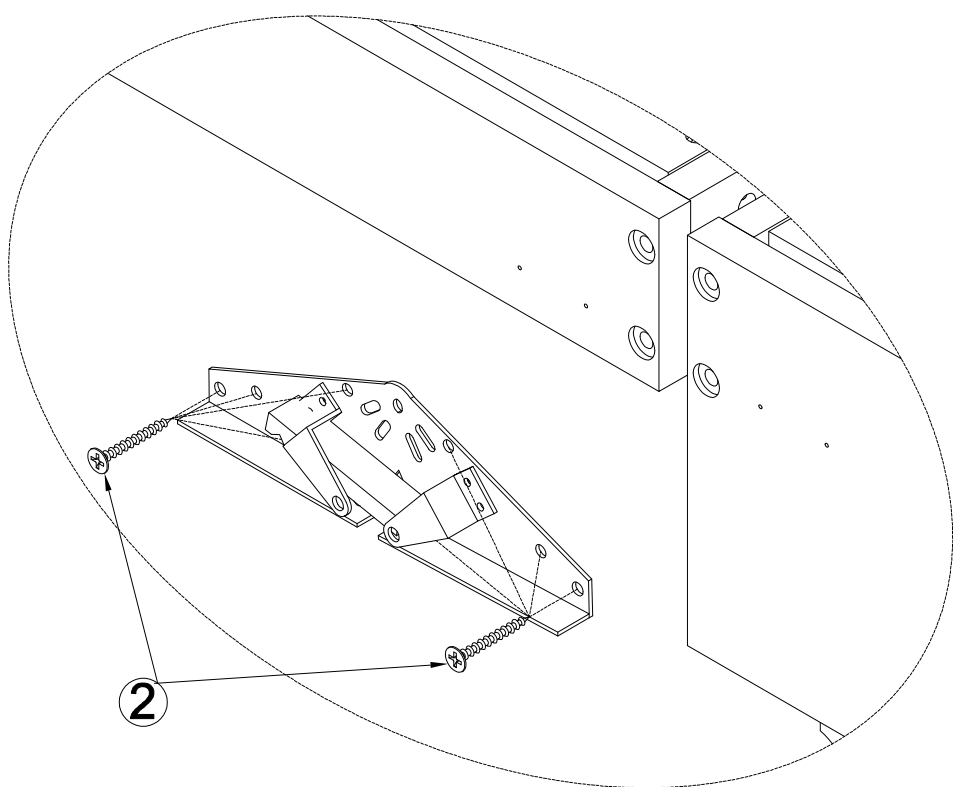
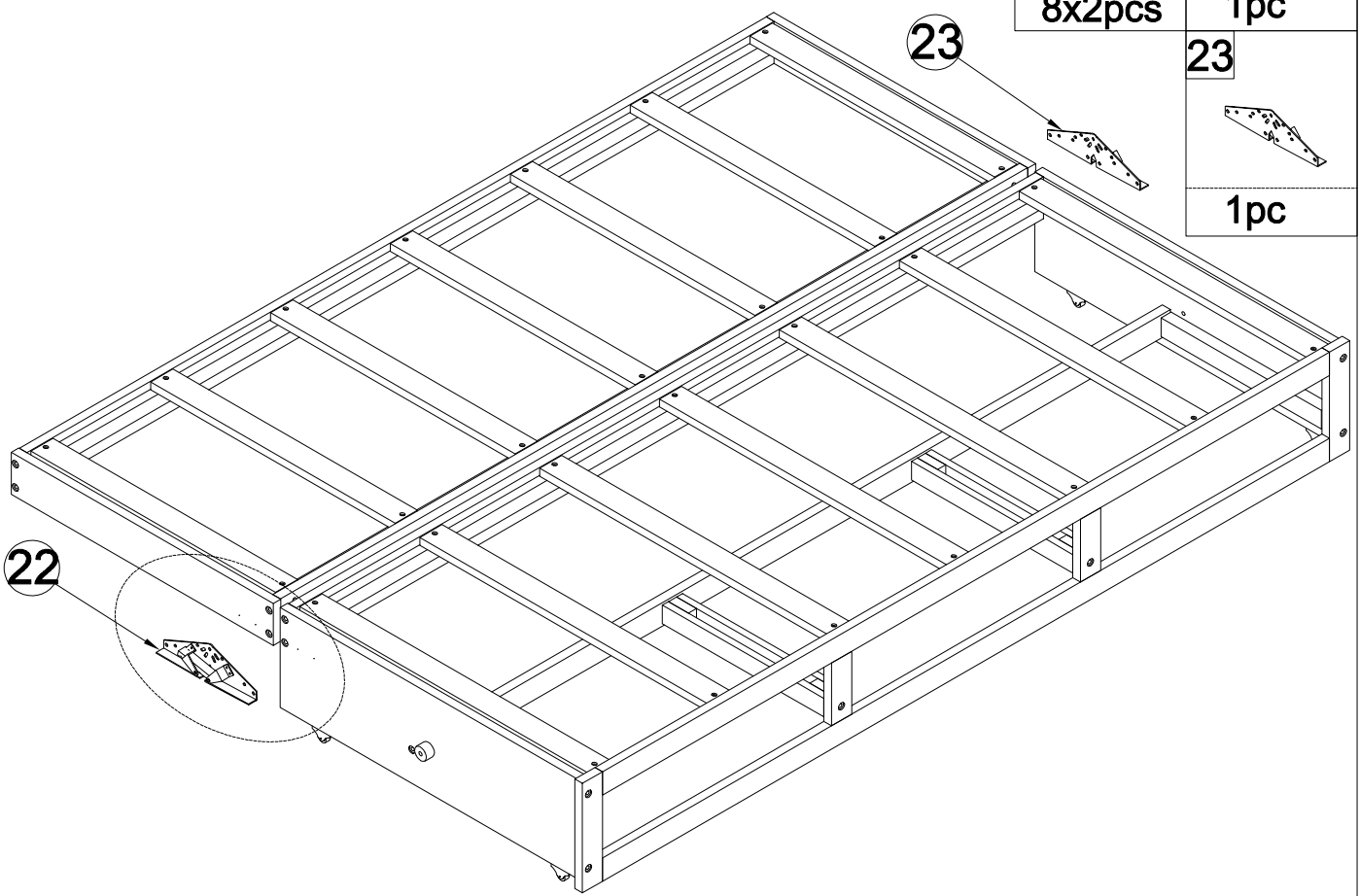

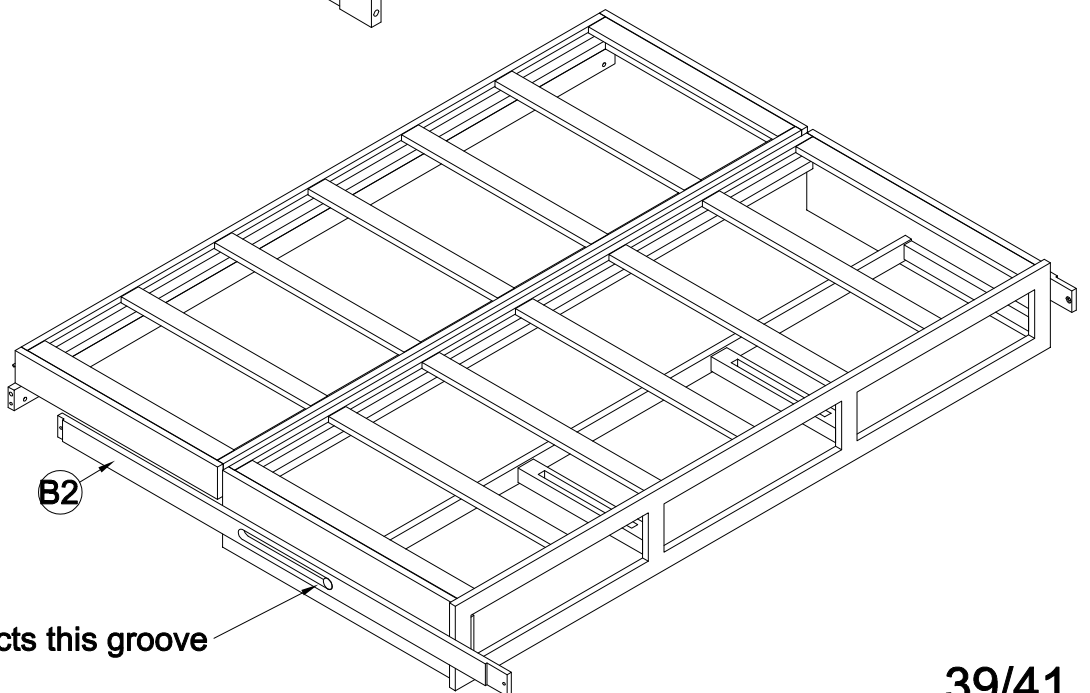
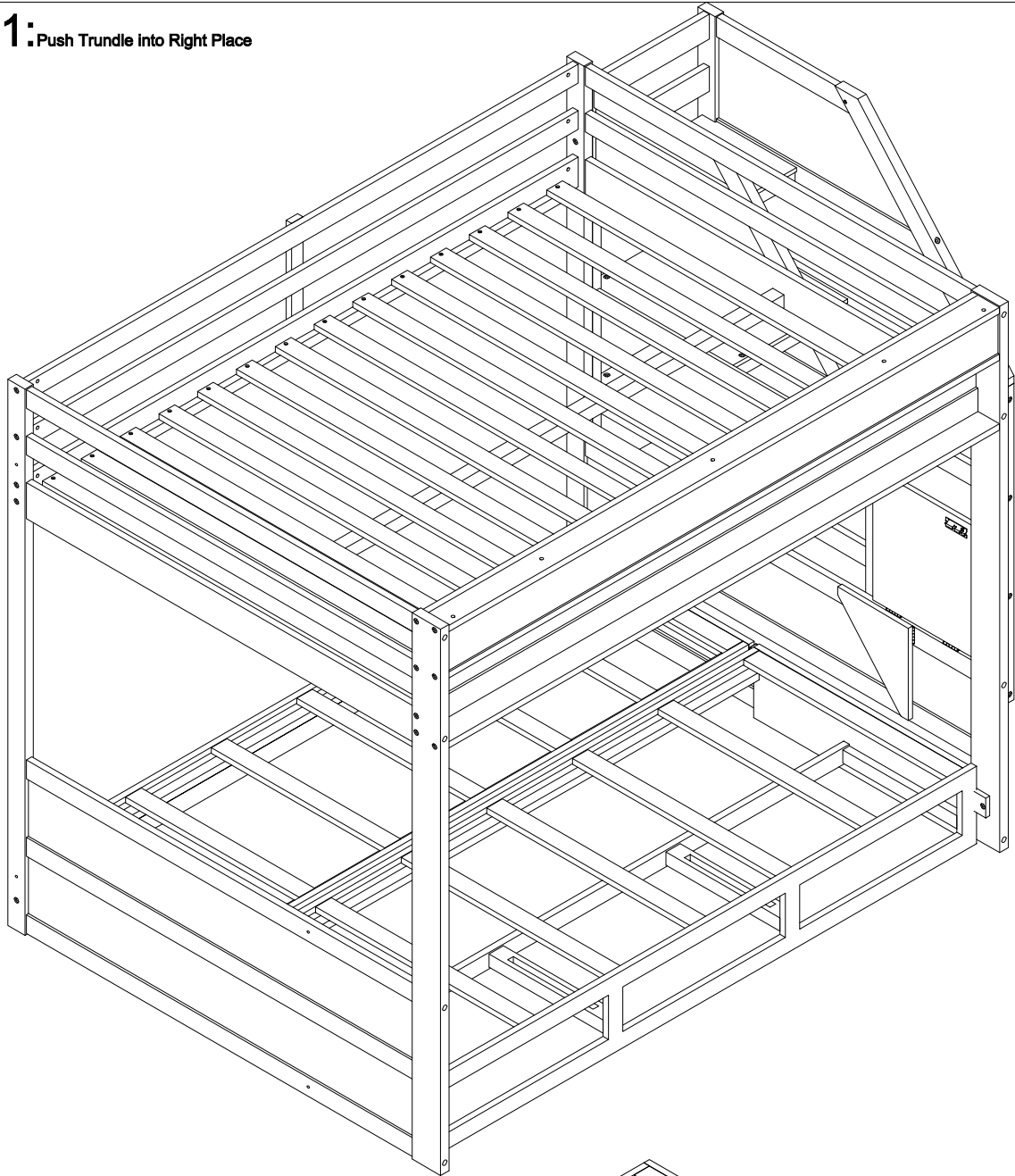

STEP 11: Push Trundle Into Right Place

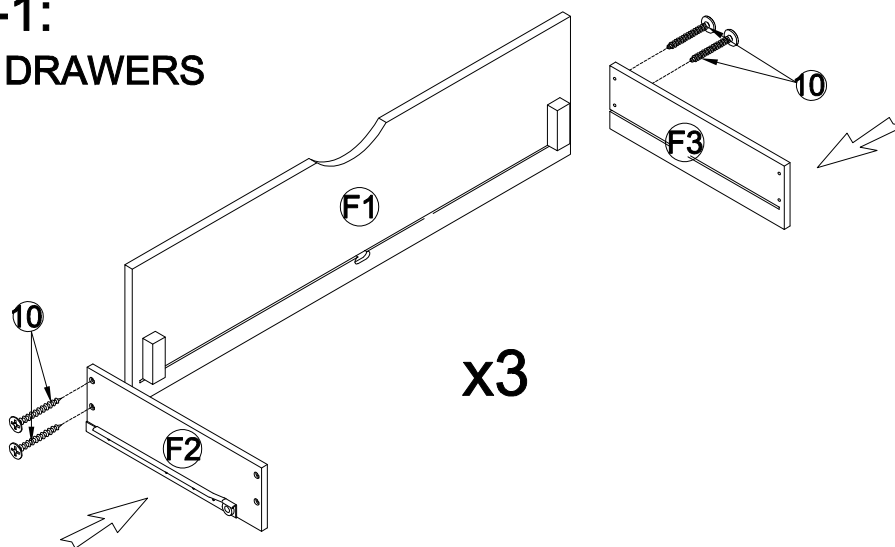

HW 21 contacts this groove

STEP 12-1: ASSEMBLY DRAWERS



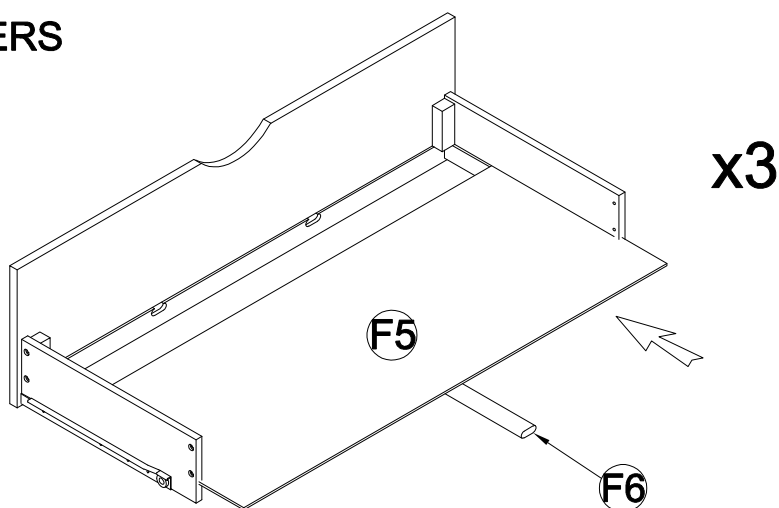

10 
4x3(pcs)

STEP 12-2: ASSEMBLY DRAWERS

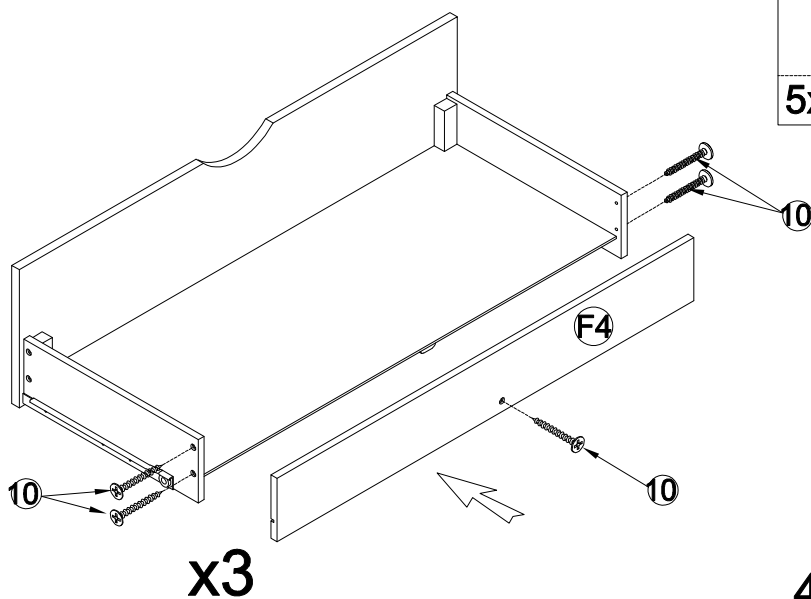

STEP 12-3: ASSEMBLY DRAWERS



10 
5x3(pcs)

STEP 13: Following below illustration:

-Push 3 Drawer in to under Bed

