

# ASSEMBLY INSTRUCTIONS

## BUNK BED WITH DESK

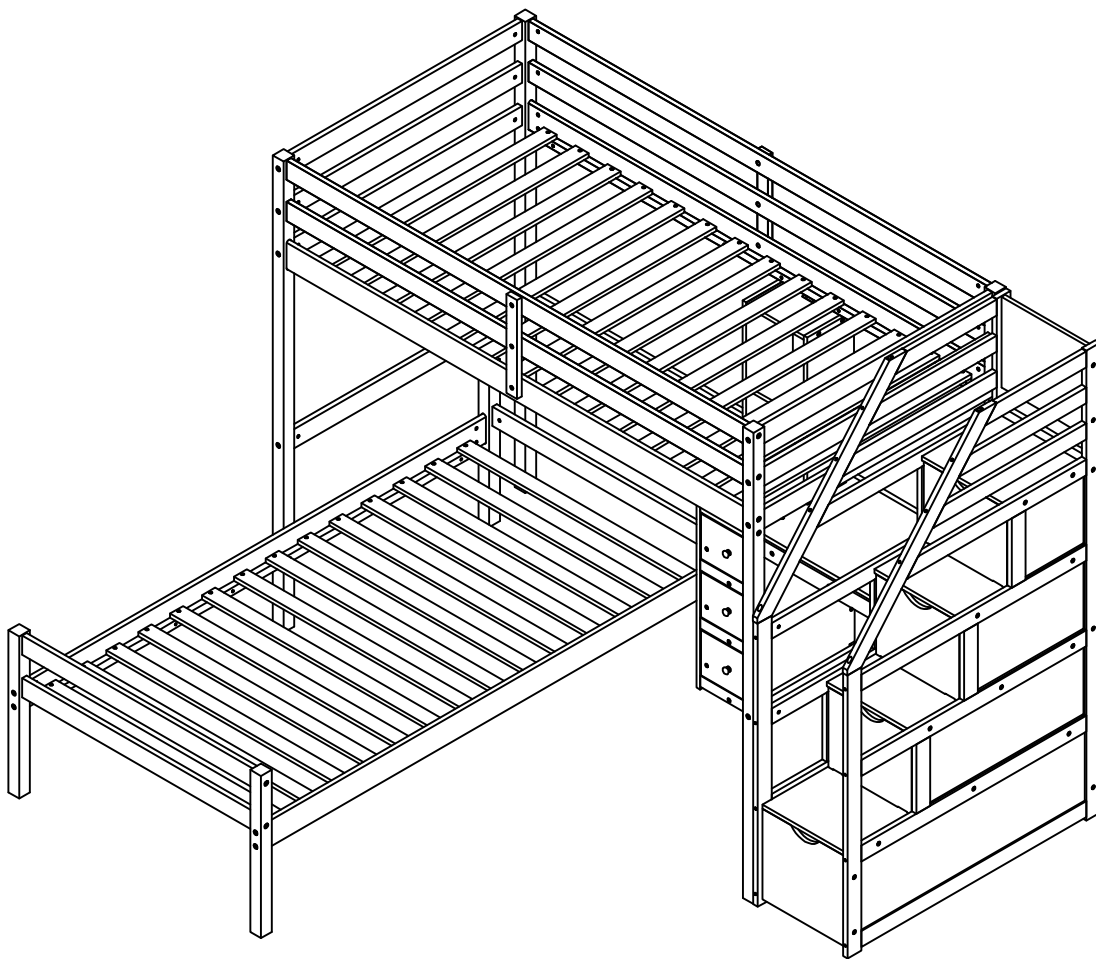

**WF295714/WF295715/WF295716**

## SAFETY WARNINGS AND GENERAL NOTES:

Follow the information on the warnings on the loft bed end structure and on the carton. Do not remove the warning label from the bed. Always use the recommended size mattress on mattress support, or both, to help prevent the likelihood of entrapment or falls.

The top surface of the mattress must be at least 5\*inch (127mm) below the upper edge of the guardrail.

Do not allow children under 6 years of age to use the upper bunk.

Periodically check and ensure the guardrail, ladder and other components are in their proper position, free from damage, and all connectors are tight.

Do not allow horseplay on or under beds.

Always prohibit jumping on the bed.

Prohibit more than one person on upper bunk.

Always use the ladder for entering and leaving the upper bunk.

Do not use substitute parts. Contact the manufacturer or dealer for replacement parts.

Use of a night-light may provide added safety precaution for a child using the upper bunk.

Always use guardrails on both long sides of the upper bunk.

If the loft bed will be placed next to a wall, the guardrail that runs the full length of the bed should be placed against the wall to prevent entrapment between the bed and the wall.

The use of water or sleep flotation mattresses is prohibited.

**STRANGULATION HAZARD**-Never attach or hang items to any part of the loft bed that are not designed for use with the bed.

Keep these instructions for future reference.

We recommend assembling your loft bed on the shipping carton to protect your floor or carpet.

Be certain all staples are out of the box before beginning assembly on the shipping carton.

**USE ONLY MATTRESSES WHICH ARE 74"-75" LONG AND 38 1/2" WIDE ON UPPER AND ON LOWER BUNKS. ENSURE THICKNESS OF MATTRESS DOES NOT EXCEED 6".**

**SURFACE OF MATTRESS MUST BE AT LEAST 5" (127MM) BELOW THE UPPER EDGE OF GUARDRAILS.**

Replacement Parts:





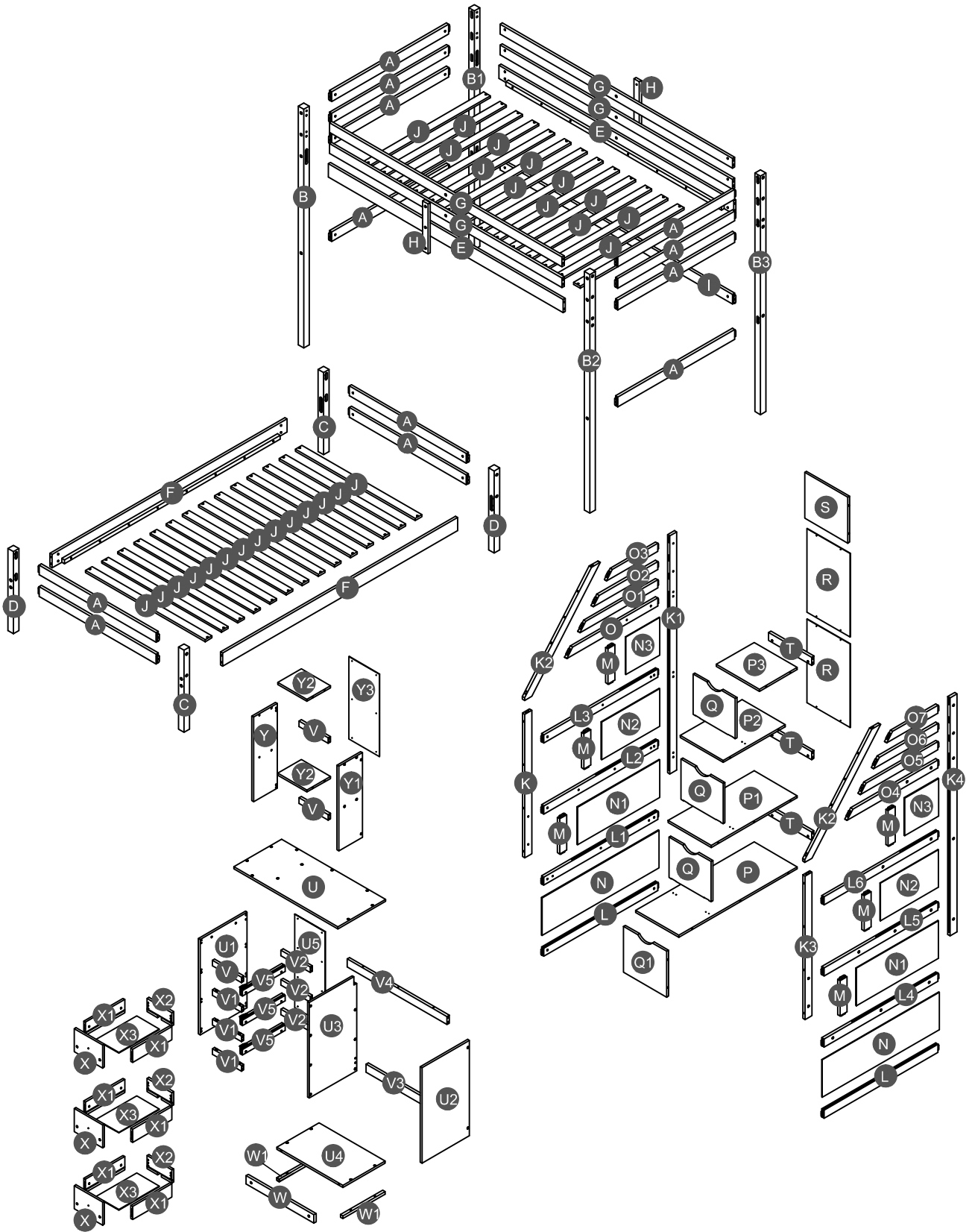





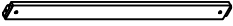
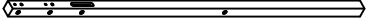
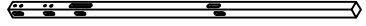
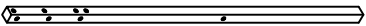
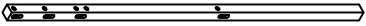

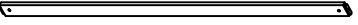
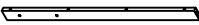
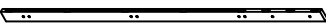
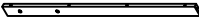
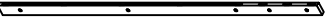
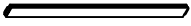
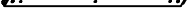

Replacement Parts, including additional guardrails, may be obtained from any of our (GIGACLOUD TECHNOLOGY (USA) INC. 18961 ARENTH AVENUE, CITY OF INDUSTRY , CA, 91748.) dealers

# Detail View

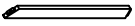

# Part List

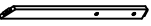
WF295714

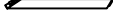





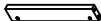
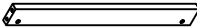
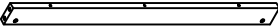
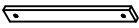
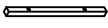

<p><b>A</b></p>  <p>Horizontal bar HB/FB - 12pcs</p>	<p><b>B</b></p>  <p>Leg (Left Front ) - 1pc</p>	<p><b>B1</b></p>  <p>Leg (Left Back) - 1pc</p>
<p><b>B2</b></p>  <p>Leg (Right Front ) - 1pc</p>	<p><b>B3</b></p>  <p>Leg (Right Back) - 1pc</p>	<p><b>E</b></p>  <p>Upper side rail (Front/Back) - 2pcs</p>
<p><b>F</b></p>  <p>Lower side rail (Front/Back) - 2pcs</p>	<p><b>G</b></p>  <p>Upper long guard rail - 4pcs</p>	<p><b>I</b></p>  <p>Lower crossbar (Back) - 1pc</p>
<p><b>K</b></p>  <p>Vertical guard (Left Front) - 1pc</p>	<p><b>K1</b></p>  <p>Vertical guard (Left Back)) - 1pc</p>	<p><b>K3</b></p>  <p>Vertical guard (Right Front) - 1pc</p>
<p><b>K4</b></p>  <p>Vertical guard (Right Back) - 1pc</p>	<p><b>L</b></p>  <p>Lower horizontal bar - 2pcs</p>	<p><b>L1</b></p>  <p>Divider horizontal bar (Left) - 1pc</p>
<p><b>L2</b></p>  <p>Divider horizontal bar (Left) - 1pc</p>	<p><b>L3</b></p>  <p>Upper horizontal bar (Left) - 1pc</p>	<p><b>L4</b></p>  <p>Divider horizontal bar (Right) - 1pc</p>
<p><b>L5</b></p>  <p>Divider horizontal bar (Right) - 1pc</p>	<p><b>L6</b></p>  <p>Upper horizontal bar (Right) - 1pc</p>	<p><b>O</b></p>  <p>Upper horizontal bar (Left) - 1pc</p>
<p><b>O1</b></p>  <p>Upper horizontal bar (Left) - 1pc</p>	<p><b>O2</b></p>  <p>Upper horizontal bar (Left) - 1pc</p>	<p><b>O3</b></p>  <p>Upper horizontal bar (Left) - 1pc</p>
<p><b>O4</b></p>  <p>Upper horizontal bar (Right) - 1pc</p>	<p><b>O5</b></p>  <p>Upper horizontal bar (Right) - 1pc</p>	<p><b>O6</b></p>  <p>Upper horizontal bar (Right) - 1pc</p>

# Part List

## WF295714



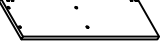









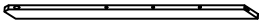

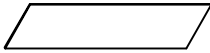
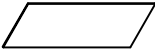
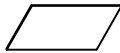



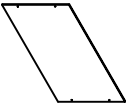
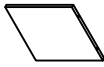

<b>O7</b>  Upper horizontal bar (Right) - 1pc	<b>T</b>  Horizontal bar (Back) - 3pcs	<b>V3</b>  Lower crossbar (Back) - 1pc
<b>V4</b>  Upper crossbar (Back) - 1pc	<b>W</b>  Support horizontal bar (Front) - 1pc	<b>W1</b>  Support shelf - 2pcs

## Hardware List WF295715

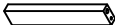
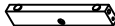

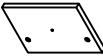
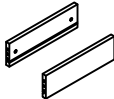

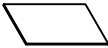

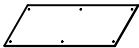



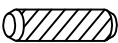

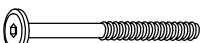



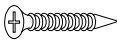

<b>J</b>  Slat - 28pcs	<b>U</b>  Top panel - 1pc	<b>U1</b>  Side panel (Left) - 1pc
<b>U2</b>  Side panel (Right) - 1pc	<b>U3</b>  Divider panel - 1pc	<b>V5</b>  Support drawer - 3pcs
<b>Y</b>  Side panel (Left) - 1pc	<b>Y1</b>  Side panel (Right) - 1pc	

# Part List

## Hardware List WF295716

<p><b>C</b></p>  <p>Leg (Left Front / Right back ) - 2pcs</p>	<p><b>D</b></p>  <p>Leg (Left back / Right Front ) - 2pcs</p>	<p><b>H</b></p>  <p>Vertical guard rail - 2pcs</p>
<p><b>K2</b></p>  <p>Guard side - 2pcs</p>	<p><b>M</b></p>  <p>Vertical guard - 6pcs</p>	<p><b>N</b></p>  <p>Lower side panel - 2pcs</p>
<p><b>N1</b></p>  <p>Divider side panel - 2pcs</p>	<p><b>N2</b></p>  <p>Divider side panel - 2pcs</p>	<p><b>N3</b></p>  <p>Upper side panel - 2pcs</p>
<p><b>P</b></p>  <p>Lower step ladder panel - 1pc</p>	<p><b>P1</b></p>  <p>Divider step ladder panel - 1pc</p>	<p><b>P2</b></p>  <p>Divider step ladder panel - 1pc</p>
<p><b>P3</b></p>  <p>Upper step ladder panel - 1pc</p>	<p><b>Q</b></p>  <p>Upper front panel - 3pcs</p>	<p><b>Q1</b></p>  <p>Lower front panel - 1pc</p>
<p><b>R</b></p>  <p>Back panel - 2pcs</p>	<p><b>S</b></p>  <p>Upper back panel - 1pc</p>	<p><b>U4</b></p>  <p>Shelf panel - 1pc</p>
<p><b>V</b></p>  <p>Upper crossbar - 3pcs</p>	<p><b>V1</b></p>  <p>Crossbar (Front) - 3pcs</p>	<p><b>V2</b></p>  <p>Crossbar (Back) - 3pcs</p>
<p><b>X</b></p>  <p>Drawer front - 3pcs</p>	<p><b>X1</b></p>  <p>Drawer (left/right) - 6pcs</p>	<p><b>X2</b></p>  <p>Drawer back - 3pcs</p>
<p><b>X3</b></p>  <p>Drawer bottom - 3pcs</p>	<p><b>Y2</b></p>  <p>Top &amp; Shelf panel - 2pcs</p>	<p><b>Y3</b></p>  <p>Back panel - 1pc</p>

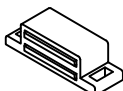
# Hardware List WF295715

<b>1</b>  Ø8*30mm Wood dowel (54pcs)	<b>2</b>  (Ø15)1/4"*100mm Hex-Head bolts (42pcs)	<b>3</b>  (Ø15)1/4"*80mm Hex-Head bolts (24pcs)
<b>4</b>  (Ø12)1/4"*60mm Hex-Head bolts (72pcs)	<b>5</b>  (Ø12)1/4"*30mm Hex-Head bolts (10pcs)	<b>6</b>  1/4"*15 (9.5mm) Horizontal-Hole bolts(138pcs)
<b>7</b>  Ø3.5*15mm Wood screws (42pcs)	<b>8</b>  (Ø12)1/4"*65mm Hex-Head bolts (18pcs)	<b>9</b>  (Ø12)1/4"*40mm Hex-Head bolts (22pcs)
<b>10</b>  (1/4")4.5*58mm Allen key (1pc)	<b>11</b>  Ø4*30mm Wood screws (56pcs)	<b>12</b>  340*30mm Upper slider drawer (3pcs)
<b>13</b>  Ø3.5*12mm Wood screws (45pcs)	<b>14</b>  3/16"*25mm Ph zinc(Knob) (3pcs)	<b>15</b>  Ø10*40mm Wood dowel (8pcs)
<b>16</b>  Ø38*31mm Pine Knob (3pcs)	<b>17</b>  50*24*24*2mm Metal bracket (5pcs)	<b>18</b>  45*17*13mm Door catch (3pcs)
<b>19</b>  42*12*1mm Metal magnet (3pcs)	<b>20</b>  350*25mm Upper slider drawer (4pcs)	

## ASSEMBLY TOOLS REQUIRED ( NOT INCLUDED )

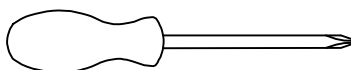

PLEASE BE CAREFUL DO NOT DAMAGE THE HOLE POSITION WHEN YOU USE POWER TOOLS !

### STEP 1:

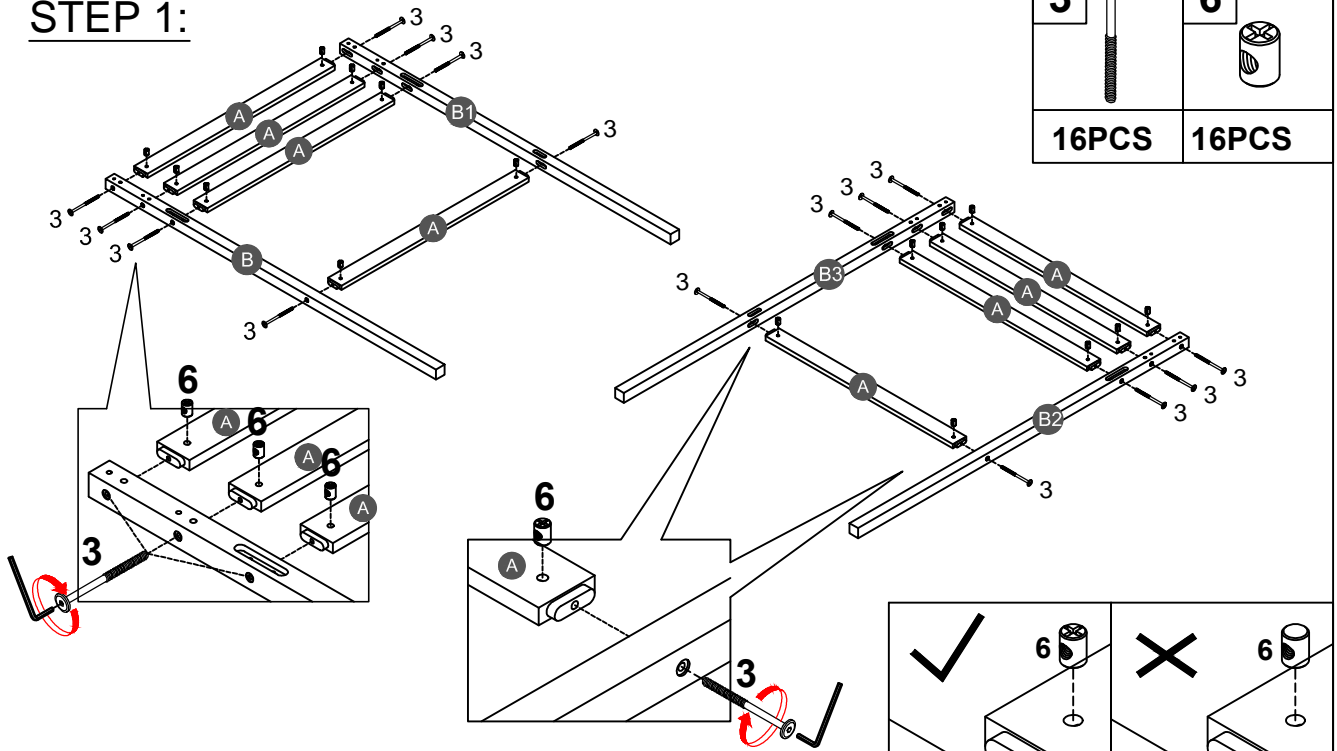

Note: Part 6 will face up with the "x" mark on it, otherwise it cannot be tightened

### STEP 2:

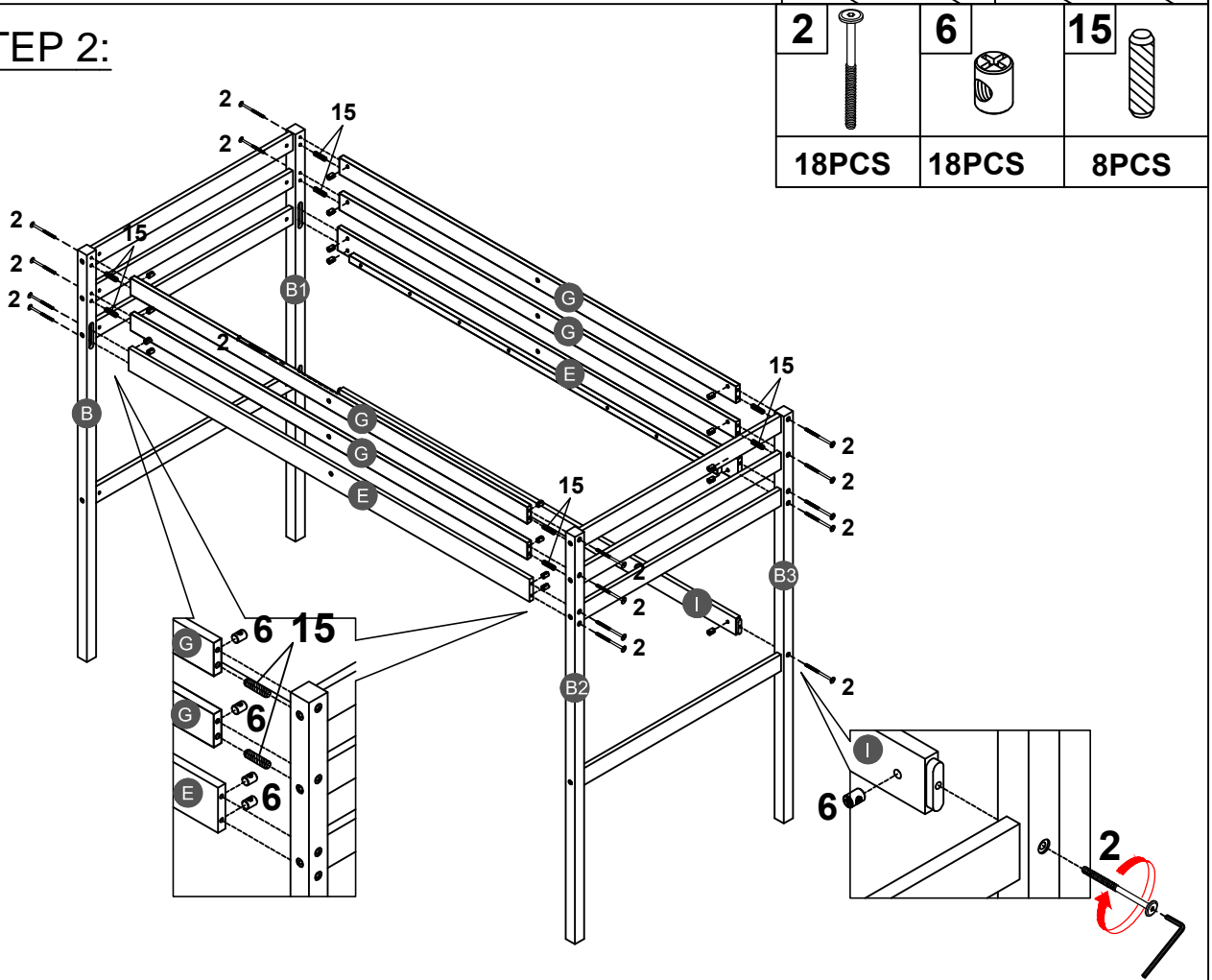



**STEP 3:**

**5**



**6PCS**

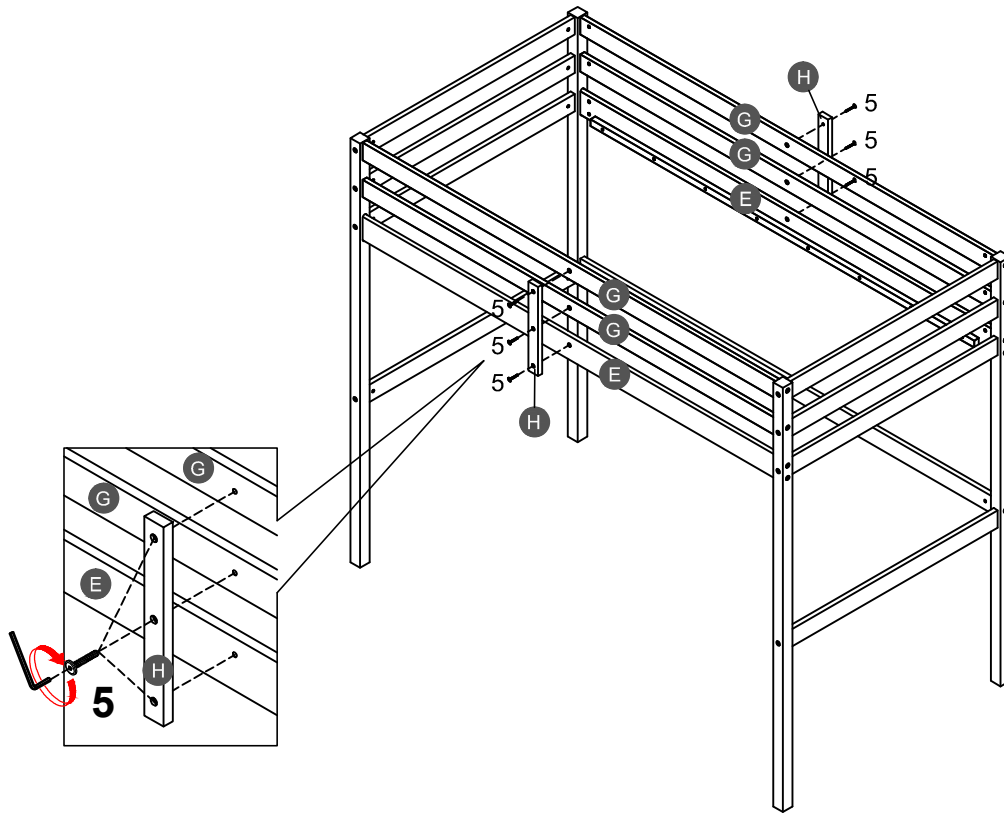

**STEP 4:**

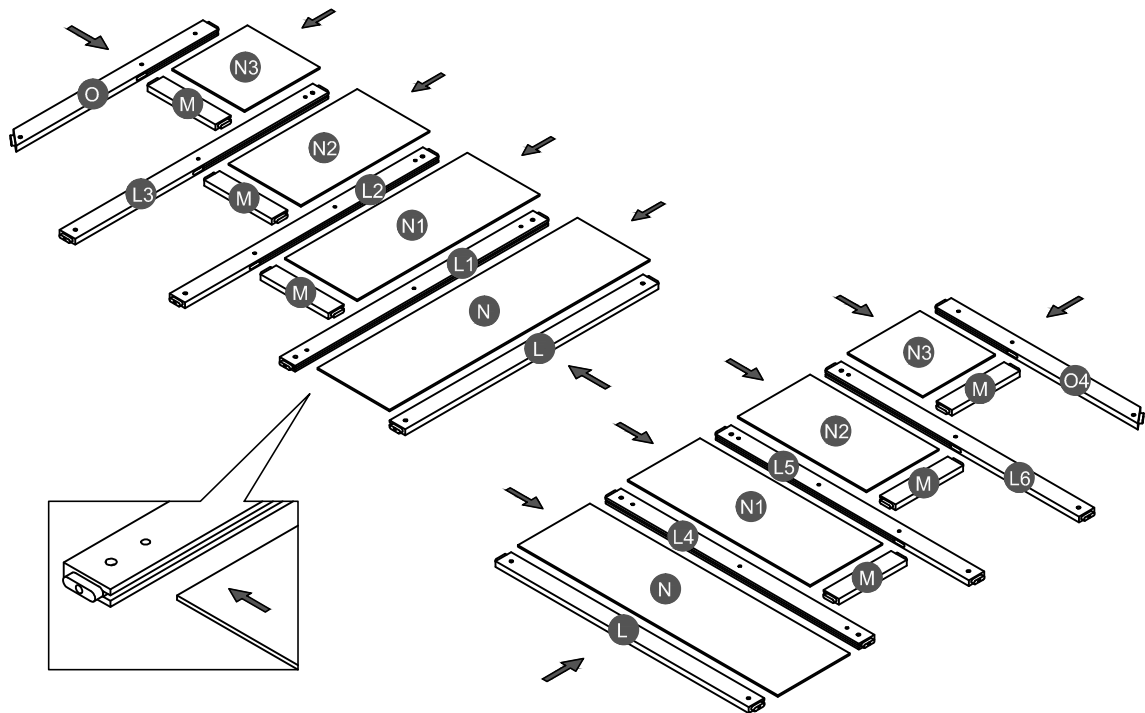

### STEP 5:

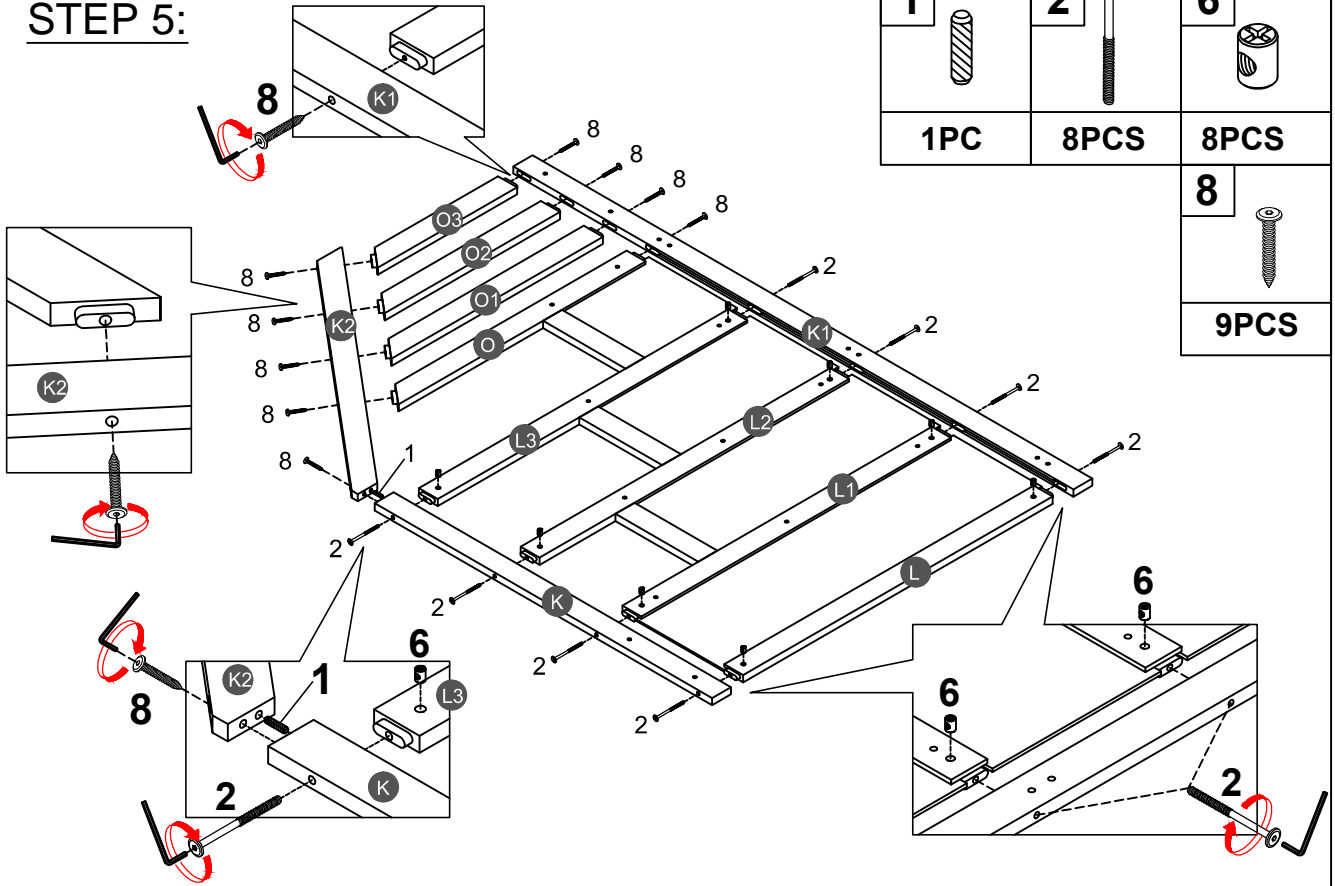

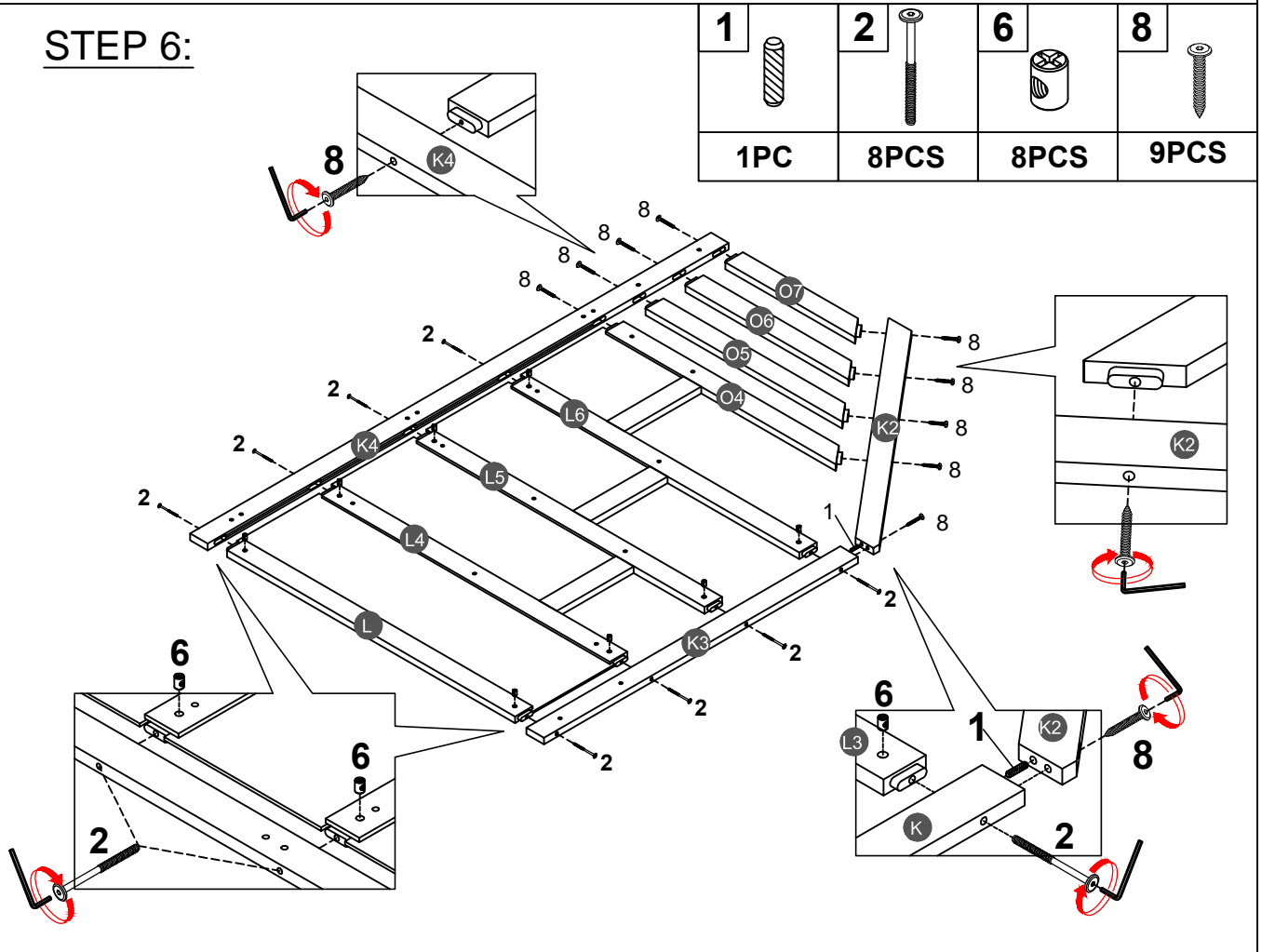

### STEP 6:



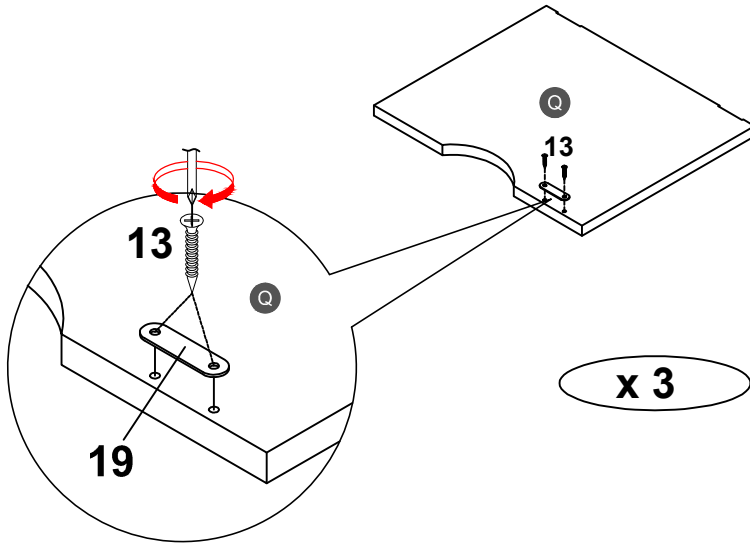

**STEP 7:**

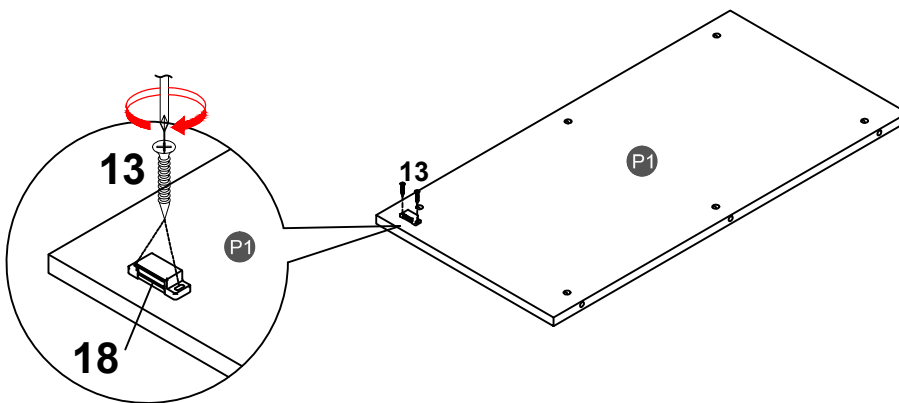

<b>13</b>		<b>19</b>	
<b>6PCS</b>		<b>3PCS</b>	

**STEP 8:**

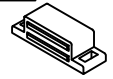

<b>13</b>		<b>18</b>	
<b>2PCS</b>		<b>1PC</b>	

**STEP 9:**

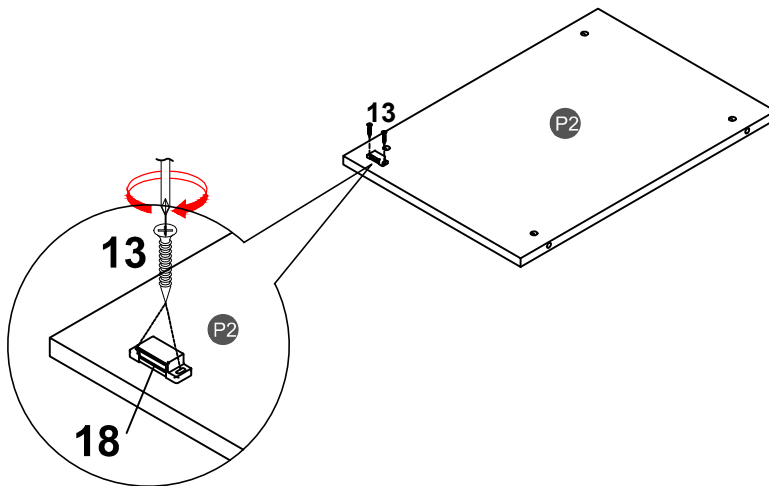

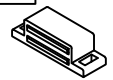

<b>13</b>		<b>18</b>	
<b>2PCS</b>		<b>1PC</b>	

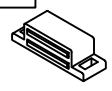
# STEP 10:

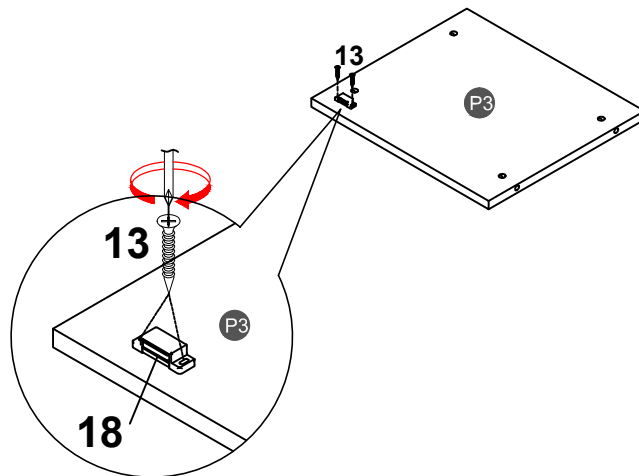
<b>13</b>		<b>18</b>	
<b>2PCS</b>		<b>1PC</b>	



# STEP 11:

<b>1</b>		<b>4</b>		<b>6</b>	
<b>6PCS</b>		<b>34PCS</b>		<b>34PCS</b>	

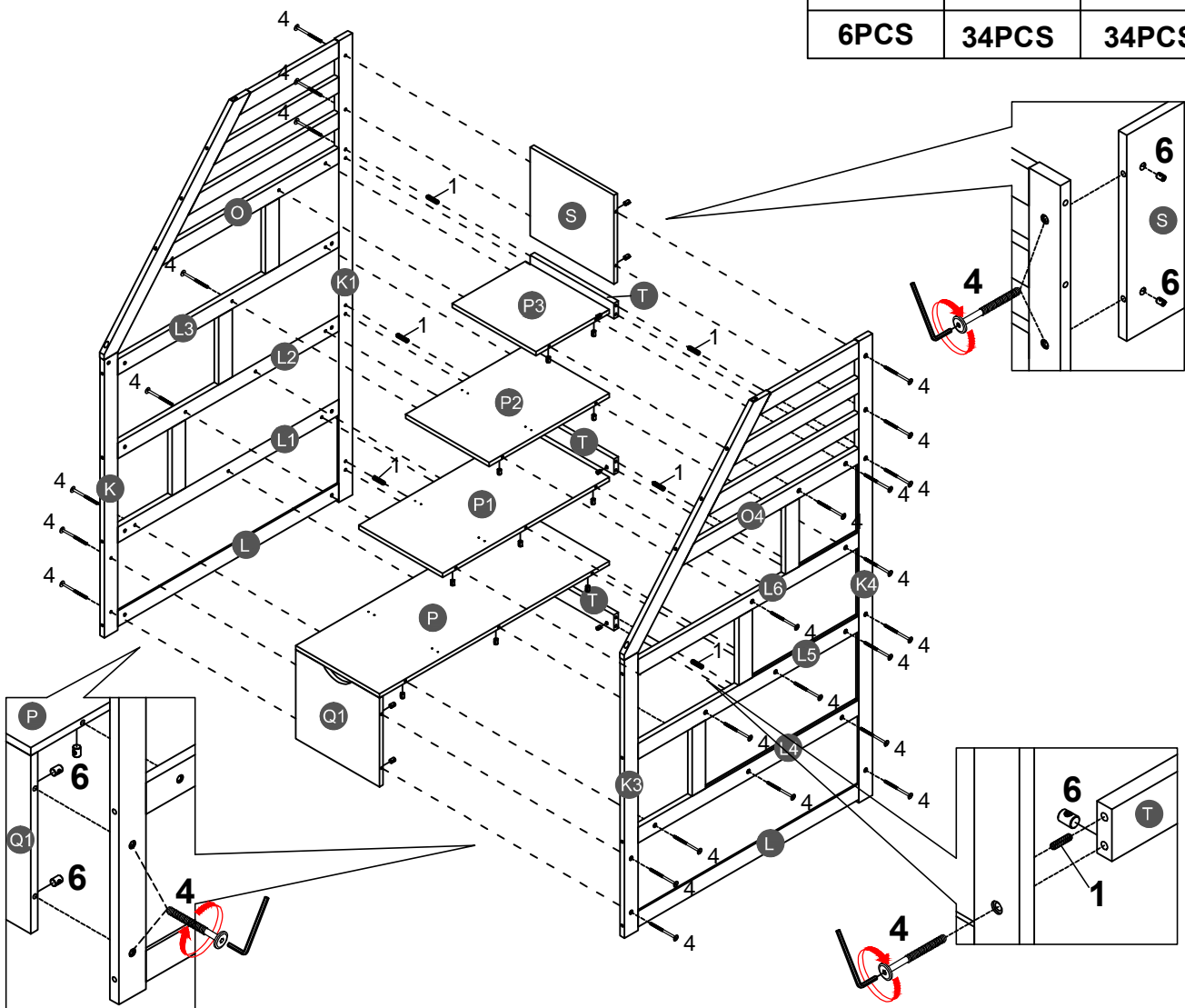

**STEP 12:**

**13**  
  
**12PCS**

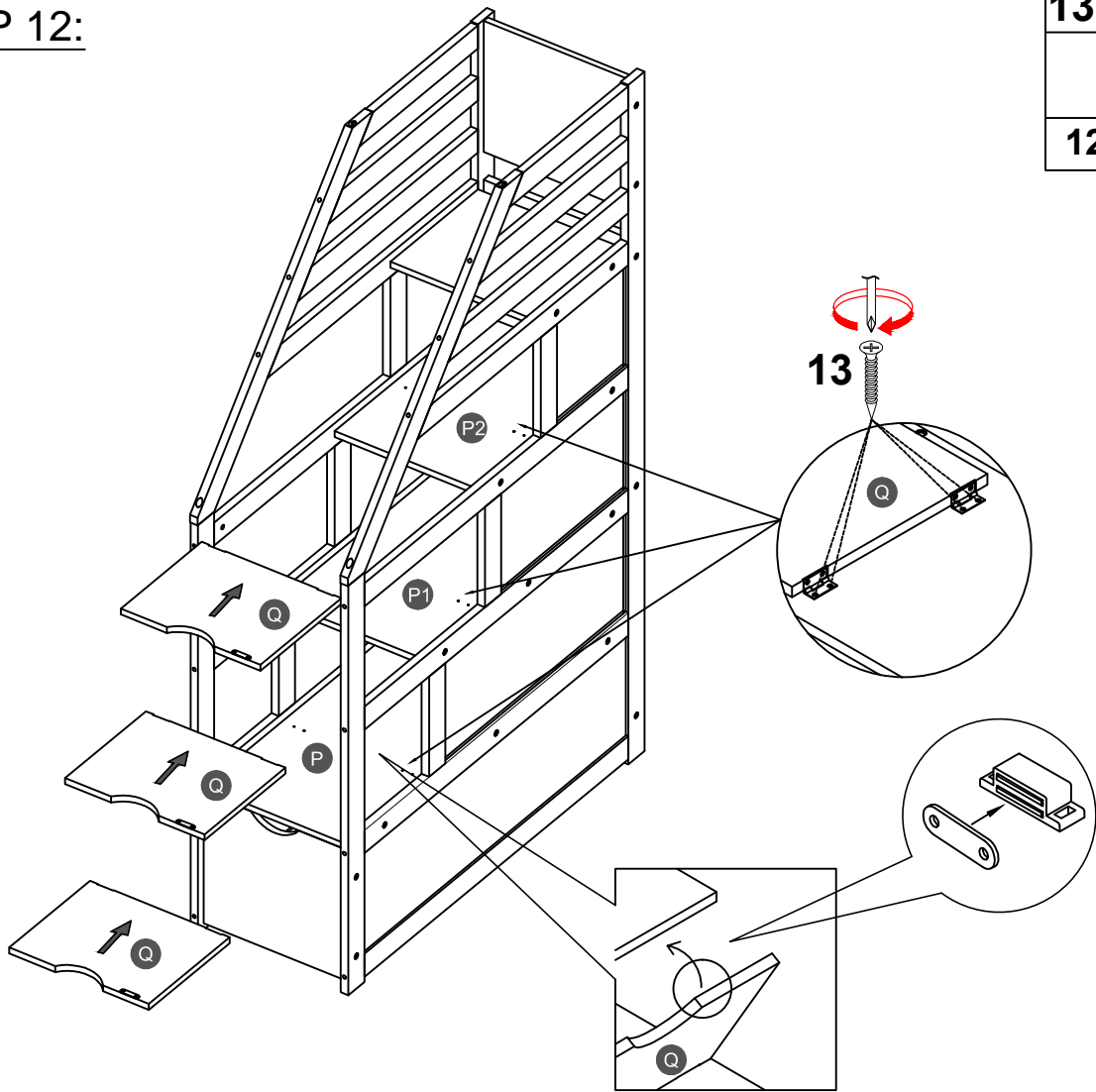

**STEP 13:**

**7**  
  
**8PCS**

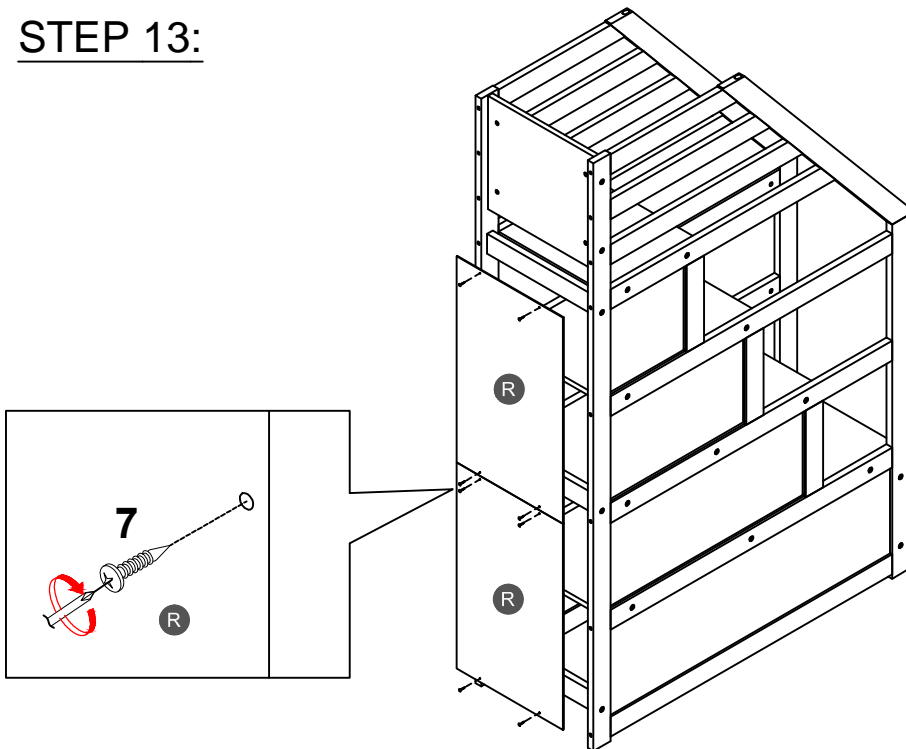

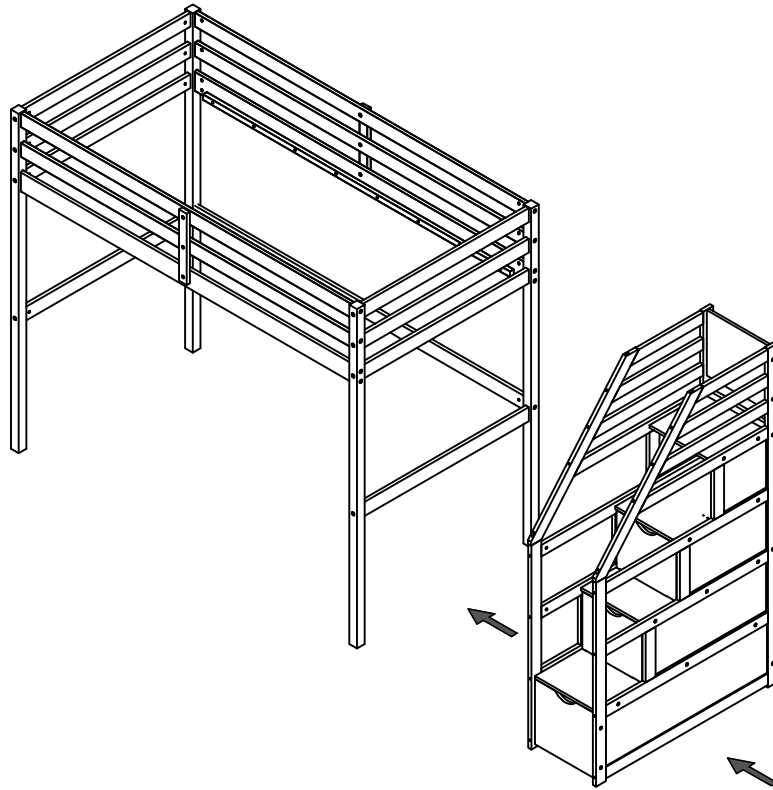

**STEP 14:**



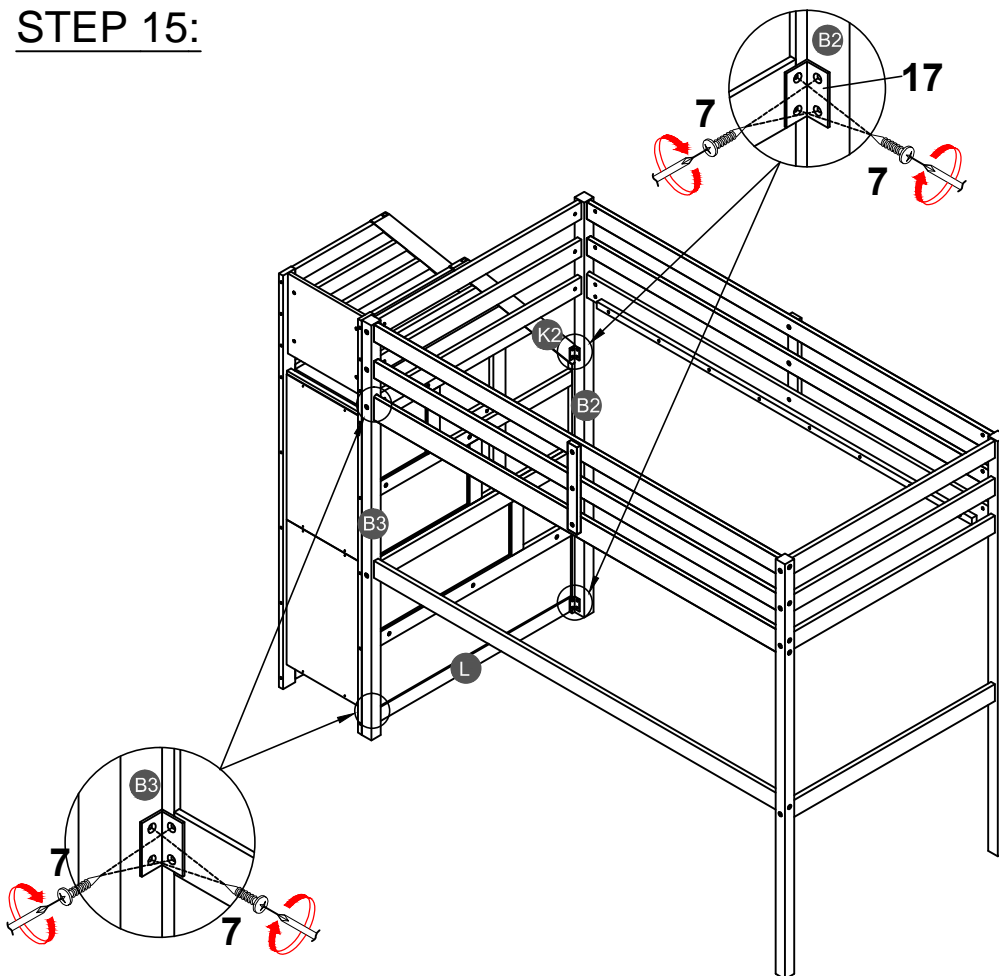

**STEP 15:**



7	17
	
16PCS	4PCS

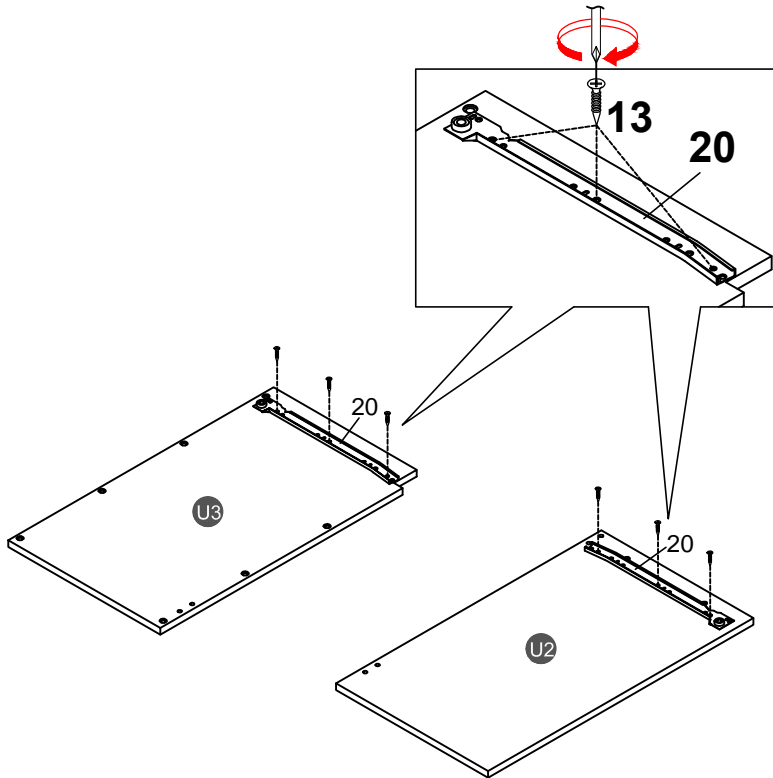

**STEP 16:**



<b>13</b>		<b>20</b>	
<b>6PCS</b>		<b>2PCS</b>	

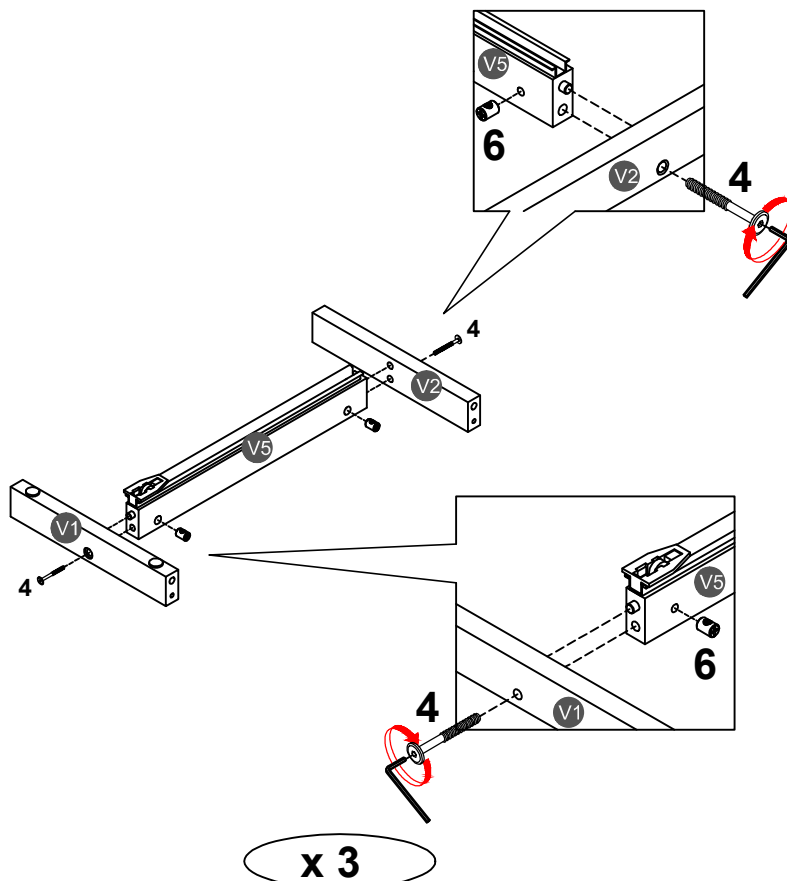

**STEP 17:**



<b>4</b>		<b>6</b>	
<b>6PCS</b>		<b>6PCS</b>	

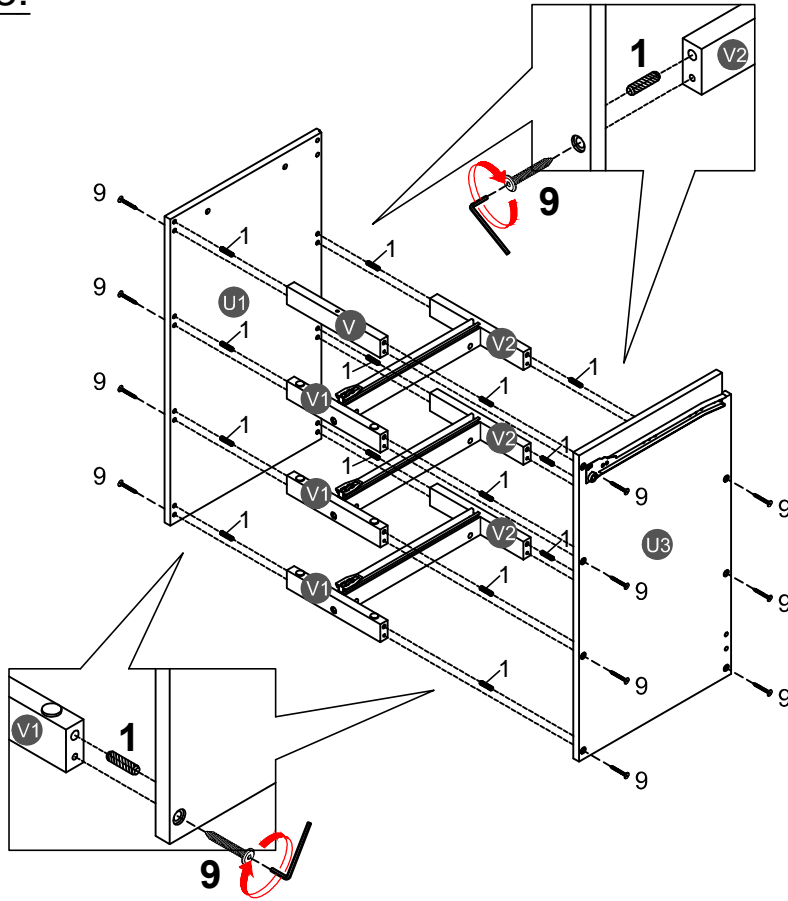

**STEP 18:**

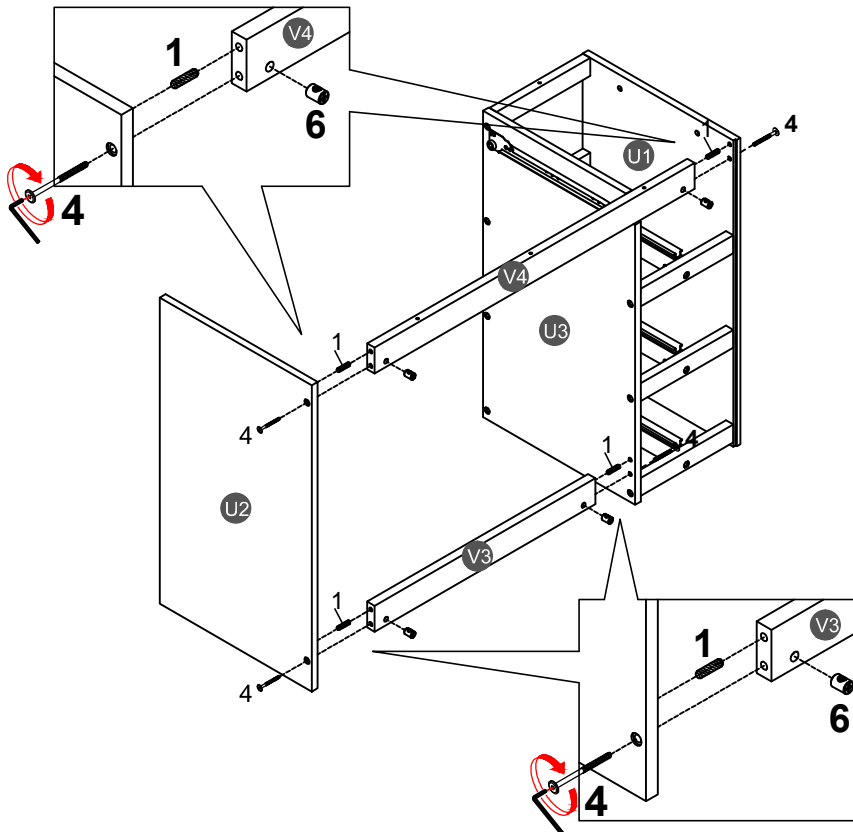

<b>1</b>		<b>9</b>	
<b>14PCS</b>		<b>14PCS</b>	

**STEP 19:**





<b>1</b>		<b>4</b>	
<b>4PCS</b>		<b>4PCS</b>	
		<b>6</b>	
		<b>4PCS</b>	



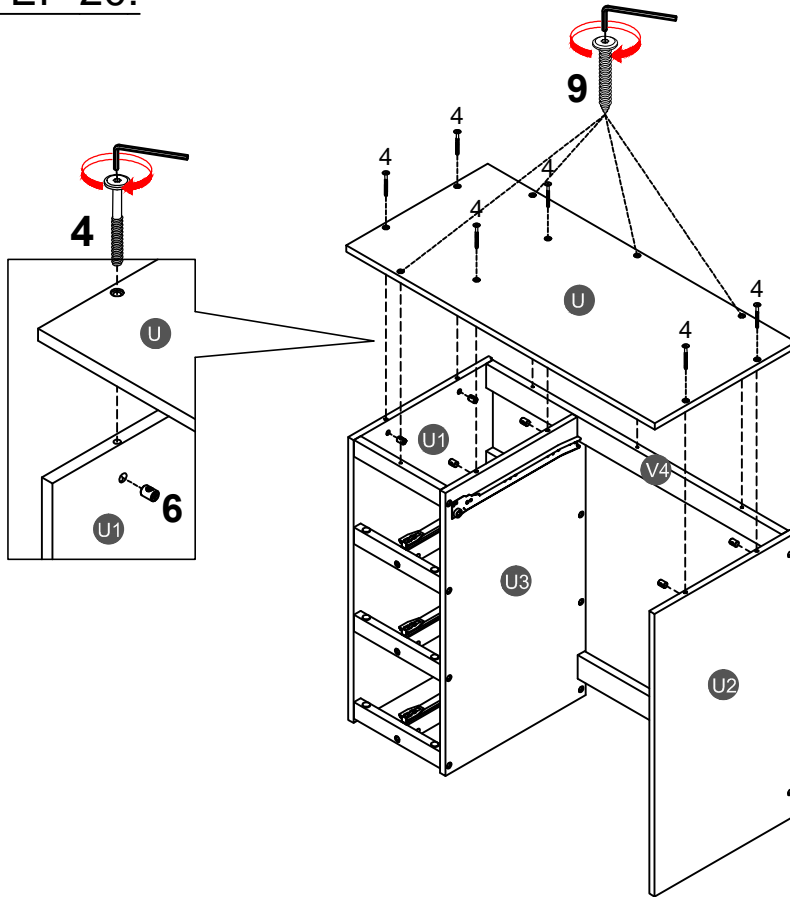

**STEP 20:**



<b>4</b>		<b>6</b>	
<b>6PCS</b>		<b>6PCS</b>	
		<b>9</b>	
<b>4PCS</b>			

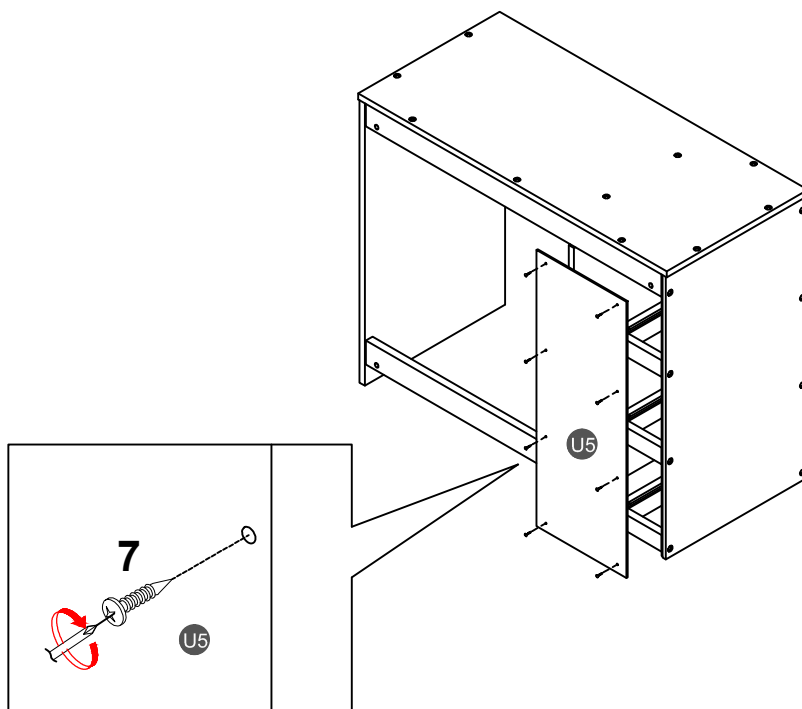

**STEP 21:**



<b>7</b>	
<b>8PCS</b>	

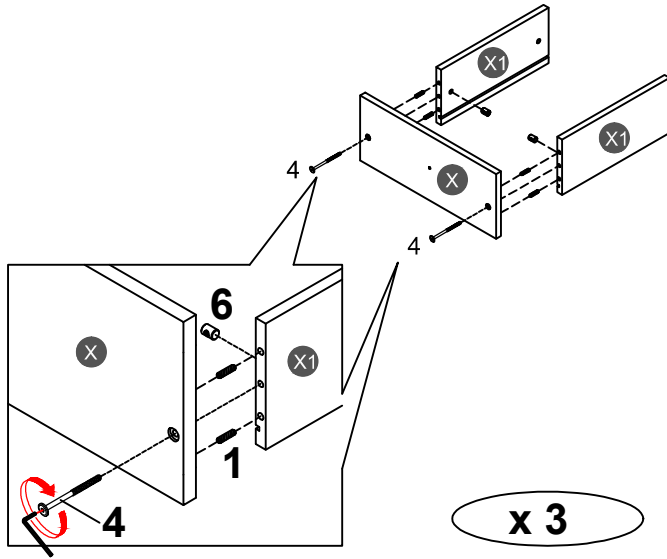

**STEP 22:**



<b>1</b>		<b>4</b>	
<b>12PCS</b>		<b>6PCS</b>	
		<b>6</b>	
<b>6PCS</b>			

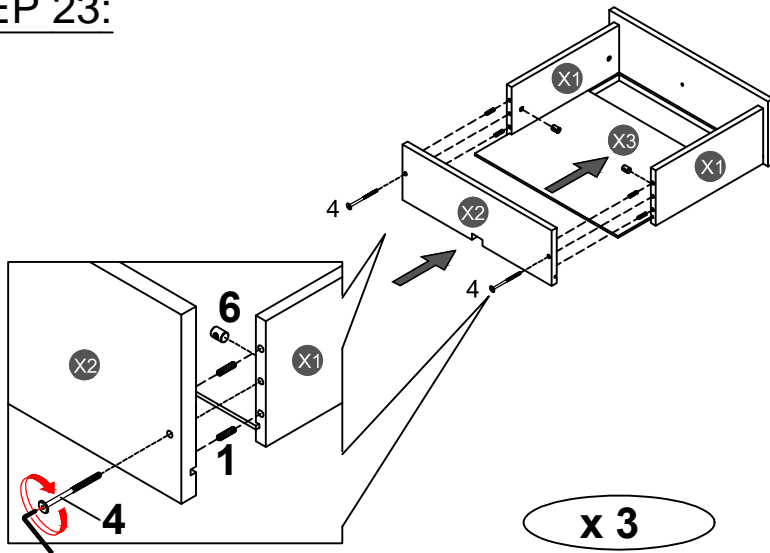

**STEP 23:**



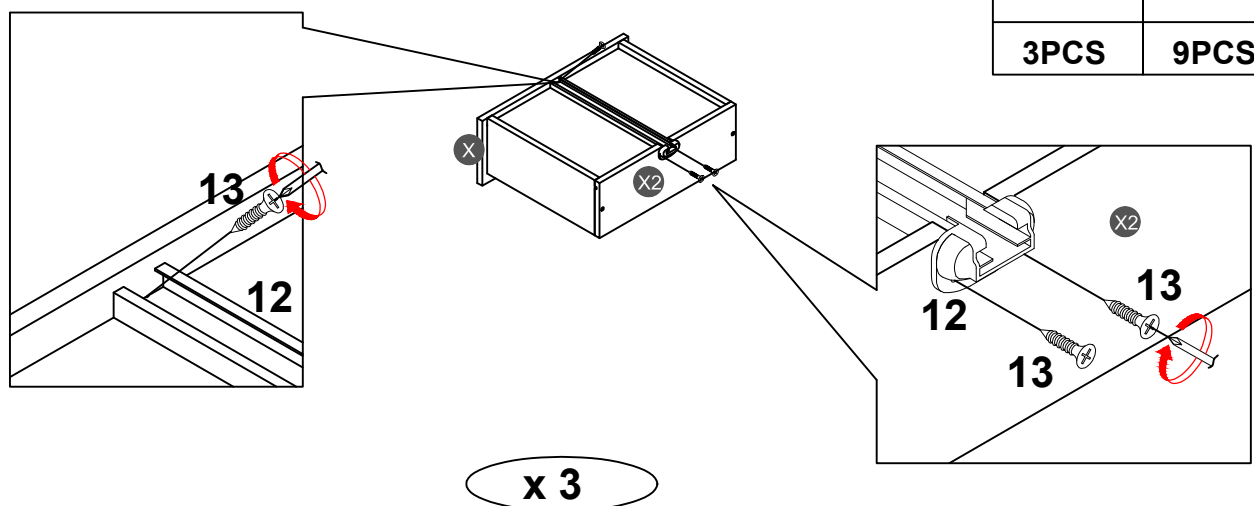

<b>1</b>		<b>4</b>	
<b>12PCS</b>		<b>6PCS</b>	
		<b>6</b>	
<b>6PCS</b>			

**STEP 24:**

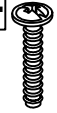

<b>12</b>		<b>13</b>	
<b>3PCS</b>		<b>9PCS</b>	

**STEP 25:**

<b>14</b>		<b>16</b>	
<b>3PCS</b>		<b>3PCS</b>	

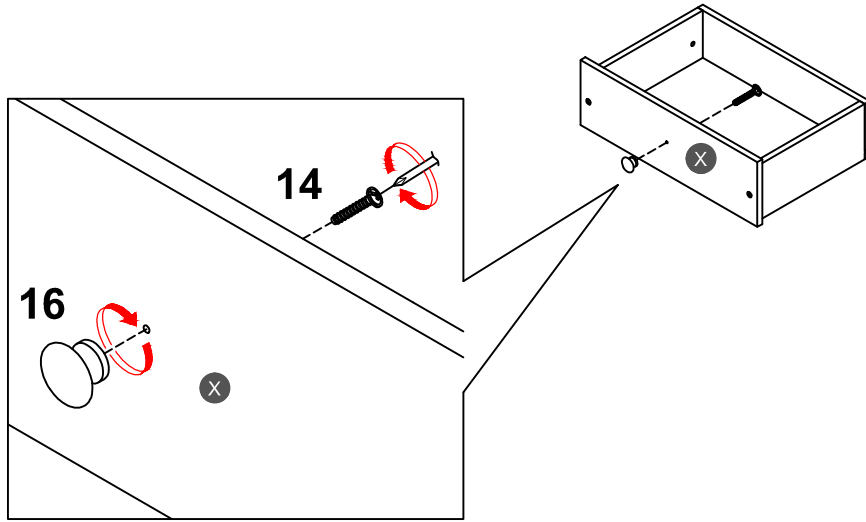

**x 3**

**STEP 26:**

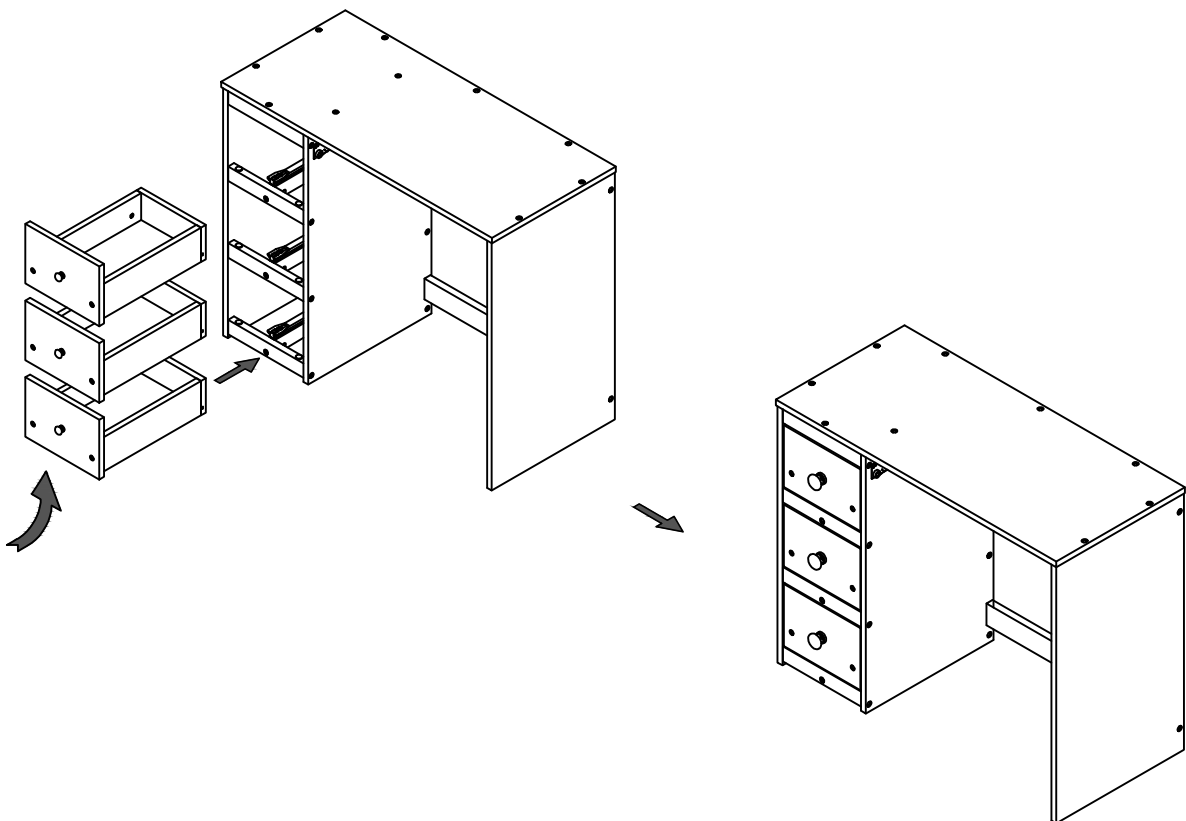

**STEP 27:**

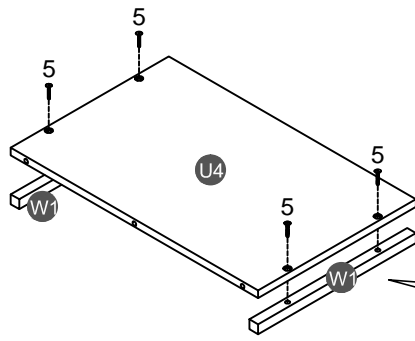

**5**



**4PCS**

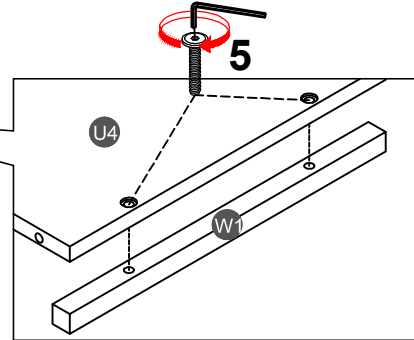

**STEP 28:**

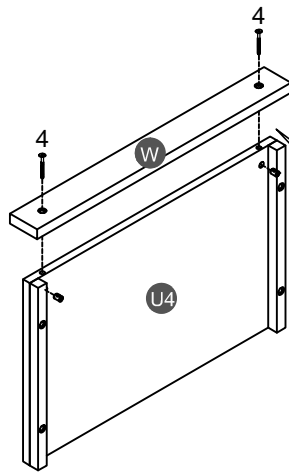

**4**



**2PCS**

**6**



**2PCS**

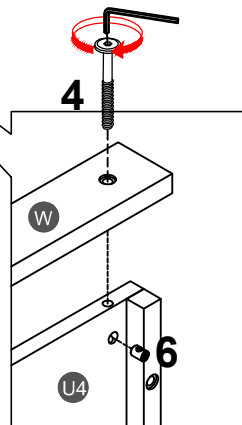

**STEP 29:**

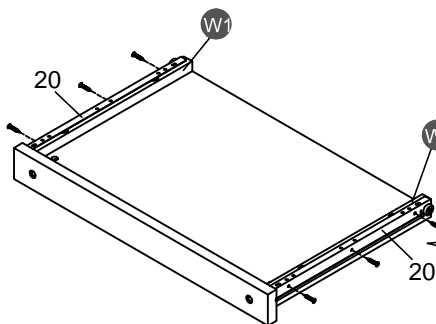

**13**



**6PCS**

**20**



**2PCS**

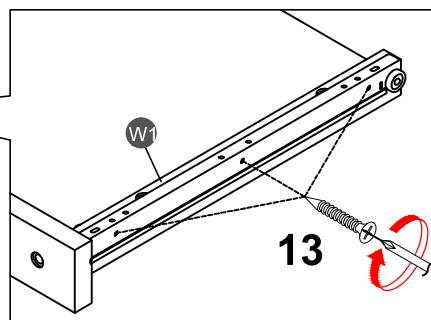



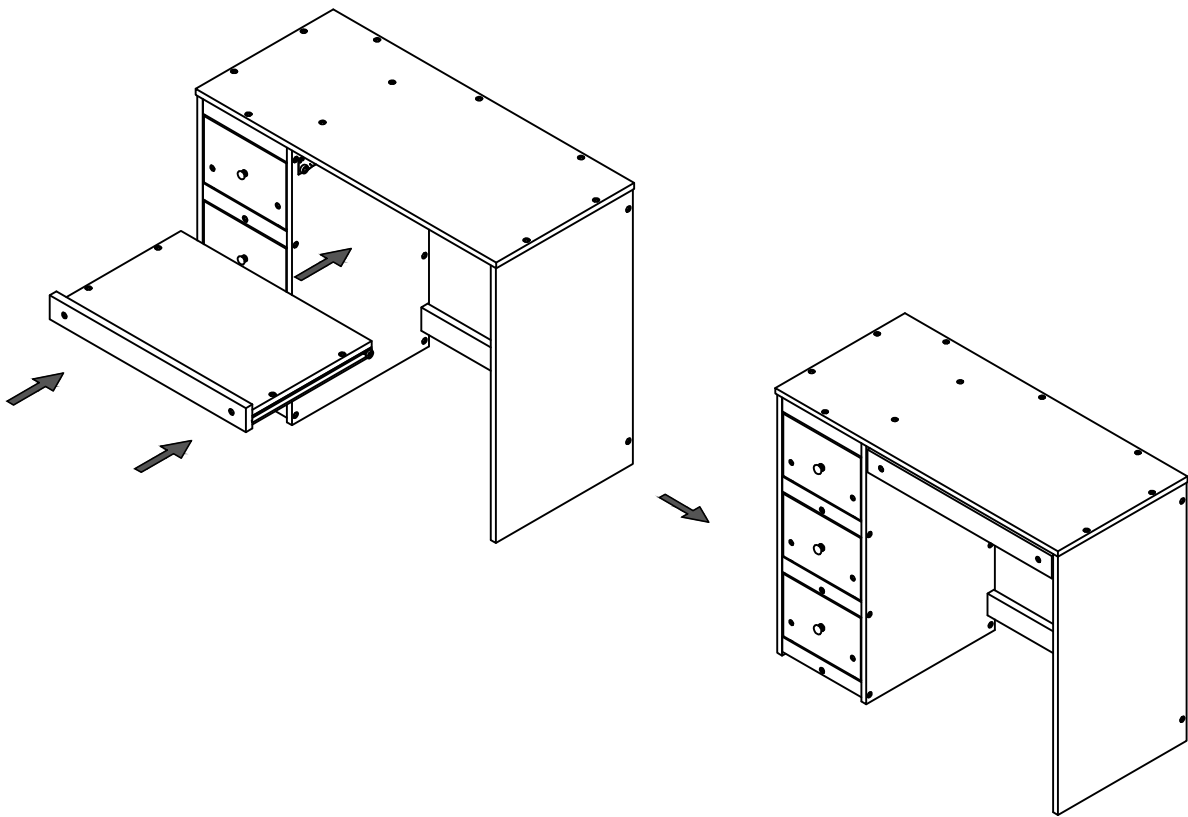

### STEP 30:

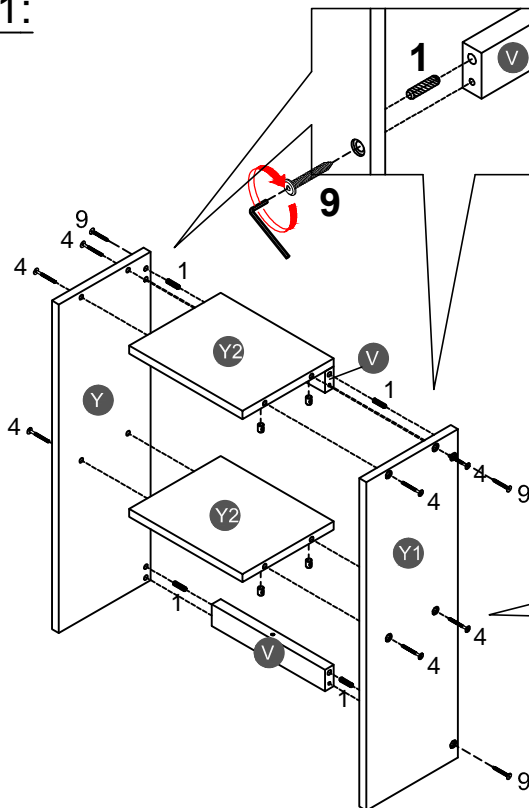

### STEP 31:



<b>1</b>		<b>4</b>		<b>6</b>	
<b>4PCS</b>		<b>8PCS</b>		<b>8PCS</b>	
				<b>9</b>	
				<b>4PCS</b>	

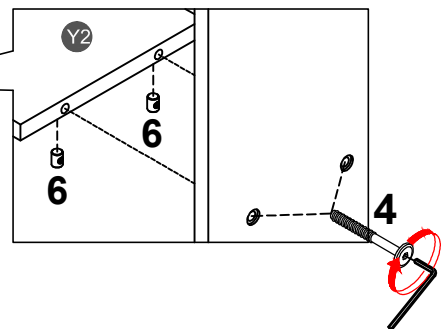

STEP 32:

7



6PCS

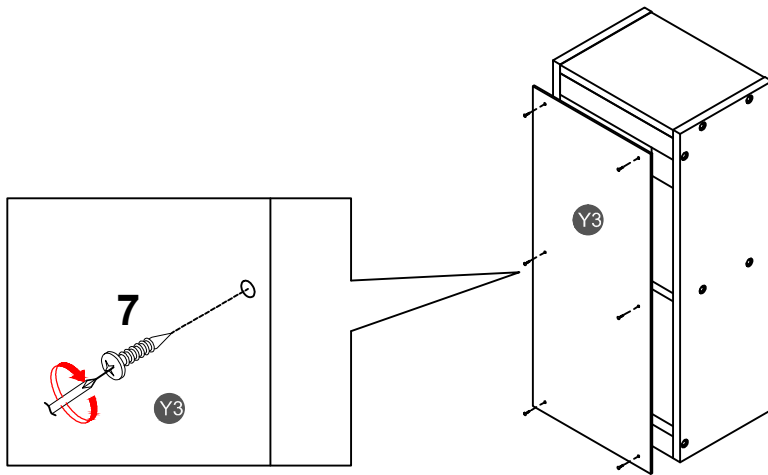

STEP 33:

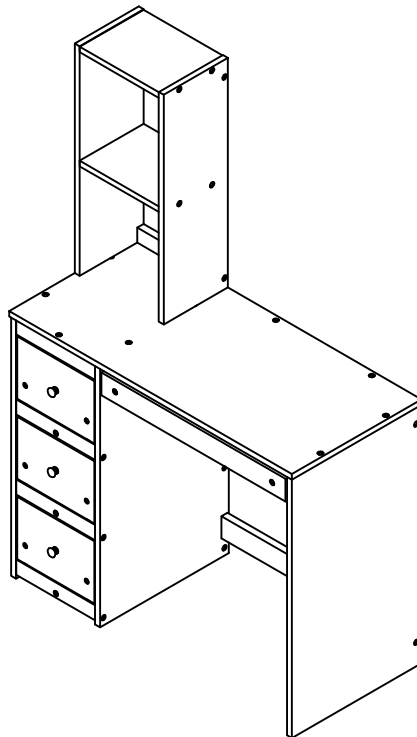

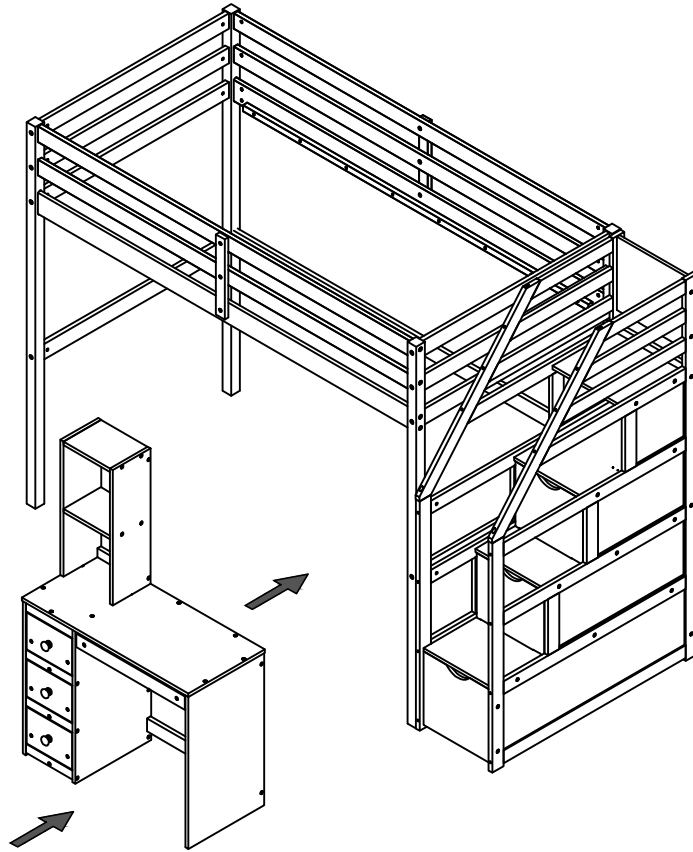

**STEP 34:**

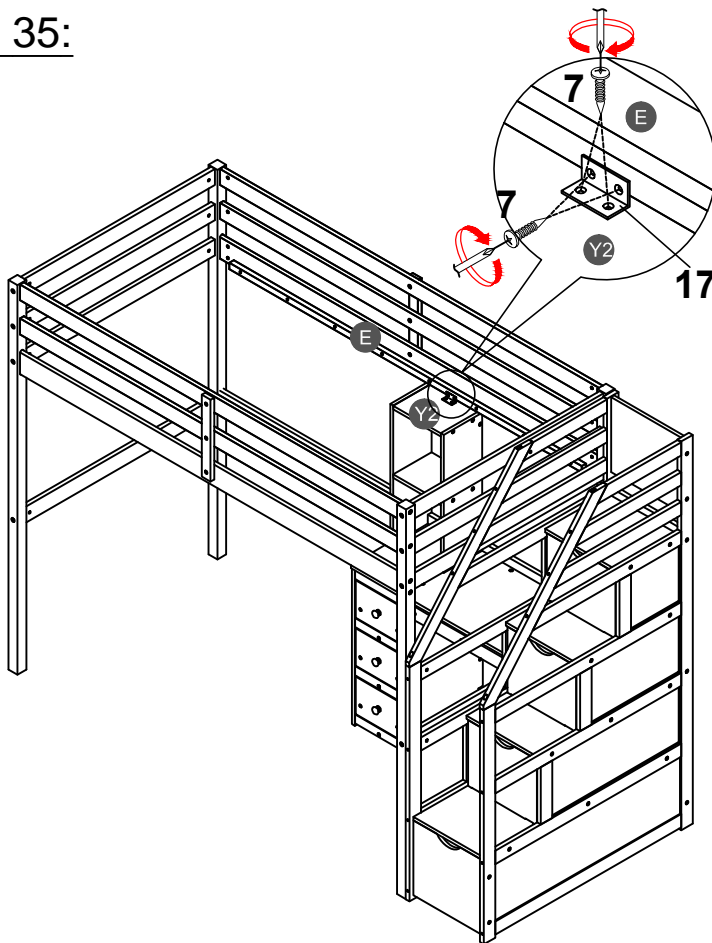

**STEP 35:**



<b>7</b>		<b>17</b>	
<b>4PCS</b>		<b>1PC</b>	

### STEP 36:

11



28PCS

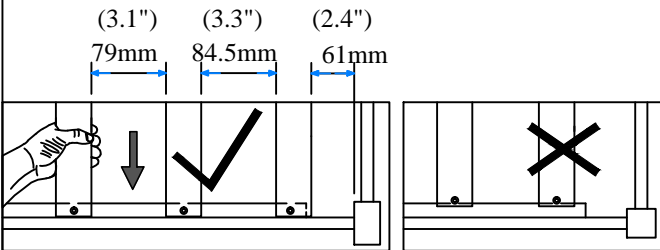
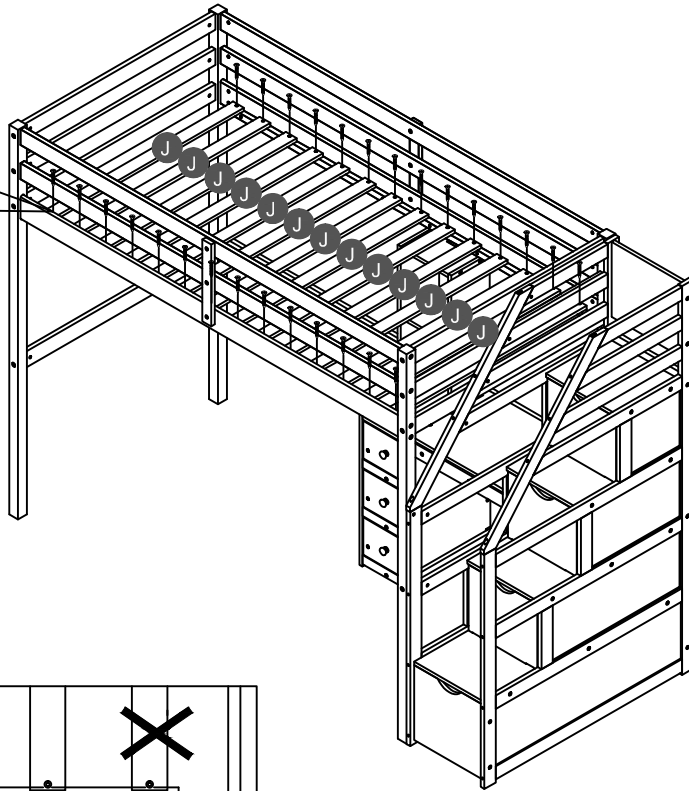
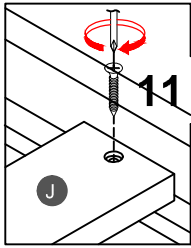

Note: Do not lock the screws of the bed slats to the outermost edge of the bed slats, you need to leave a certain space at the edges, otherwise it will cause the board to break. Do not lock the bed slats on the edge of the wood, please hold firmly before screwing, hold it in place with one hand, then lock the screw.

### STEP 37:

3

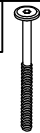

8PCS

6



8PCS

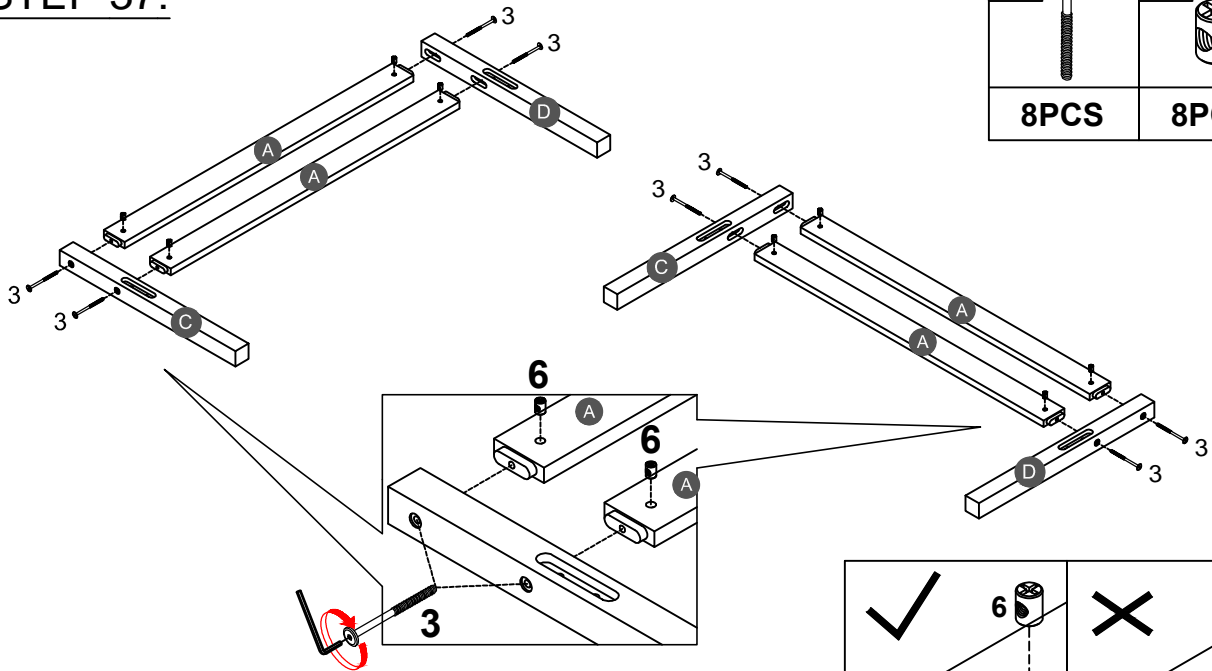

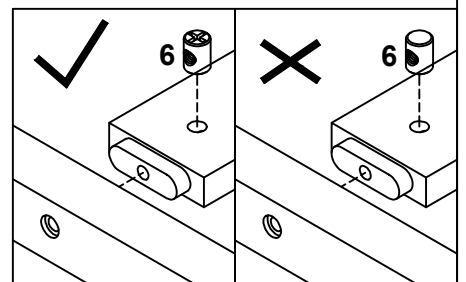

Note: Part 6 will face up with the "x" mark on it, otherwise it cannot be tightened





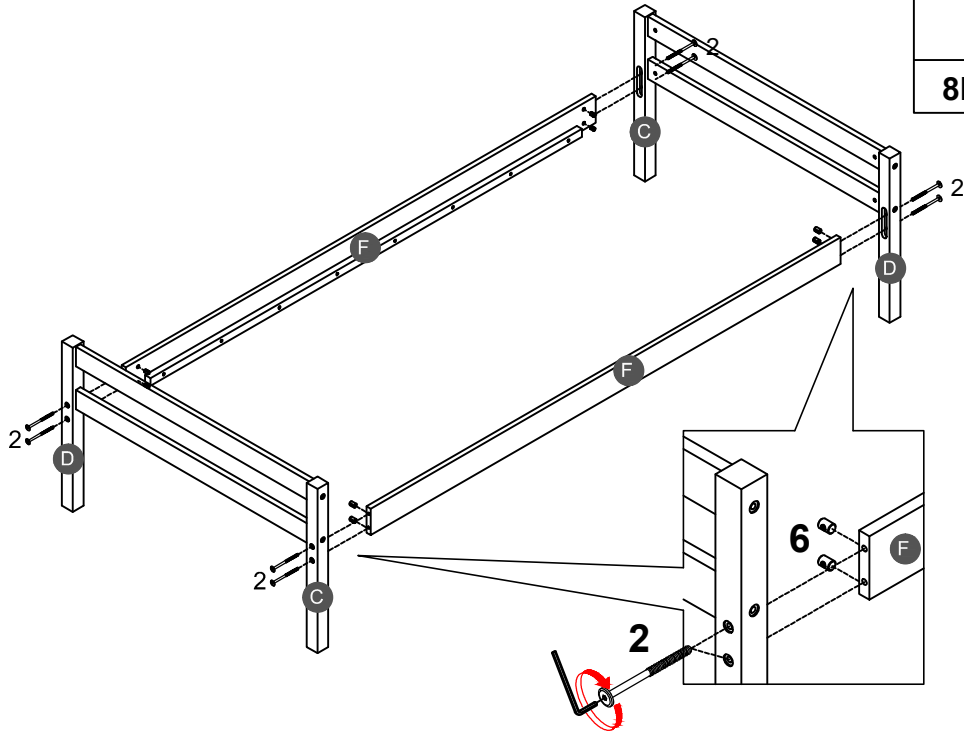

**STEP 38:**

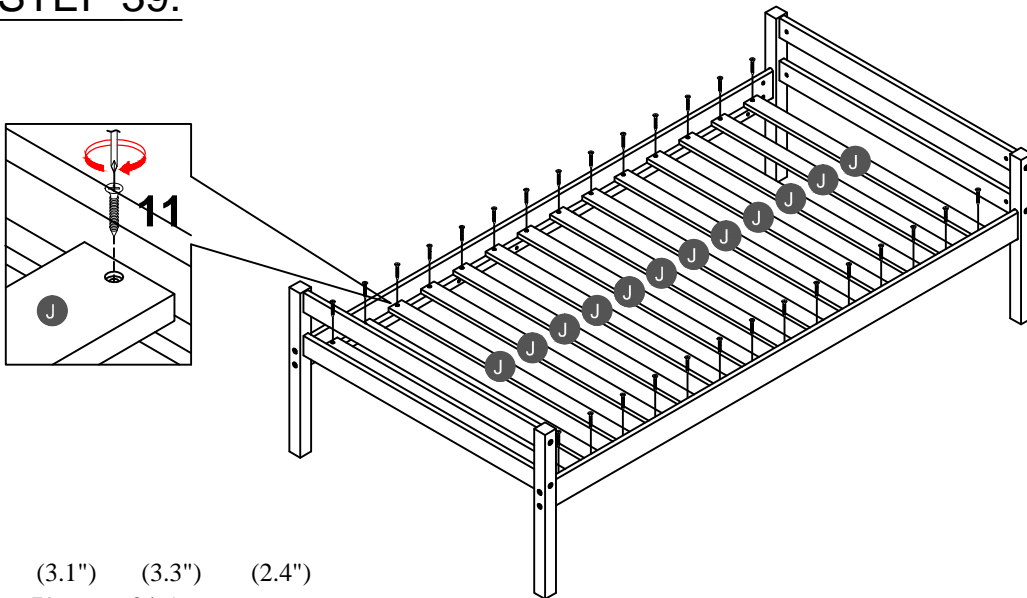

<b>2</b>		<b>6</b>	
<b>8PCS</b>		<b>8PCS</b>	

**STEP 39:**



<b>11</b>	
<b>28PCS</b>	

(3.1") 79mm    (3.3") 84.5mm    (2.4") 61mm

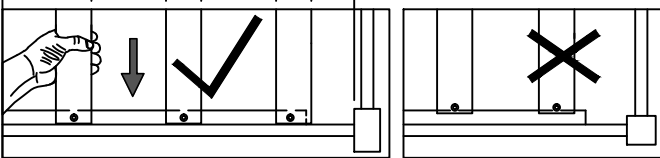

Note: Do not lock the screws of the bed slats to the outermost edge of the bed slats, you need to leave a certain space at the edges, otherwise it will cause the board to break. Do not lock the bed slats on the edge of the wood, please hold firmly before screwing, hold it in place with one hand, then lock the screw.

STEP 40:

