

Cat Tree

Instruction Manual

CW-MPJ-54IN

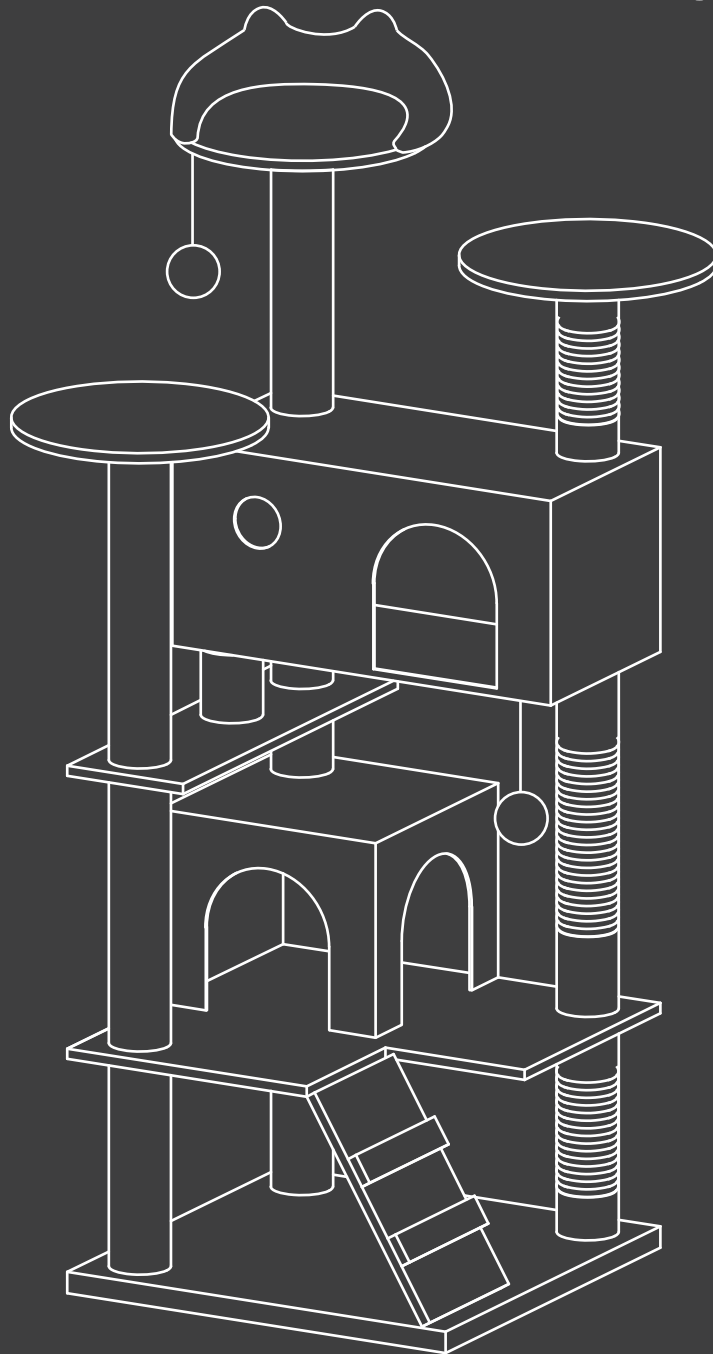

1 Package List

A X1

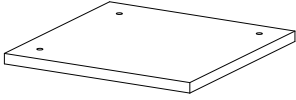

Motherboard

B X1

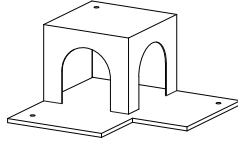

L-plate Kitten Litter

C X1

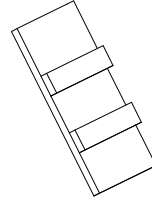

Stair Slabs

D X1

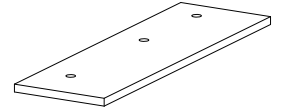

Slats

E X1

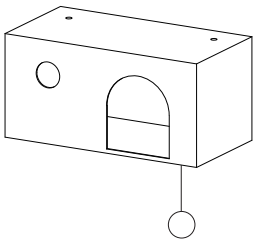

Big Cat Litter

F X2



Round Plates

G X1

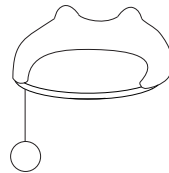

Round Plates Of Ears

P1 X2



Pillar
250mm

P2 X1



Pillar
250mm

P3 X1



Pillar
320mm

P4 X1



Pillar
92mm

P5 X1



Pillar
412mm

P6 X2



Pillar
80mm

P7 X1



Pillar
390mm

P8 X1

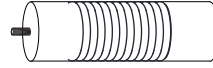

Pillar
220mm

P9 X1



Pillar
320mm

P10 X8

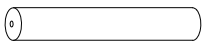

Pillar
210mm

2 Supplied Parts and Hardware

1 X4



Screws
M8x15mm

2 X2

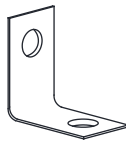

Angle Iron

3 X27



Screws
M8x35mm

4 X4



Screws
M8x65mm

5 X1

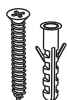

Expansion Screws

6 X1



Wrench

7 X2



Gasket

Step 1

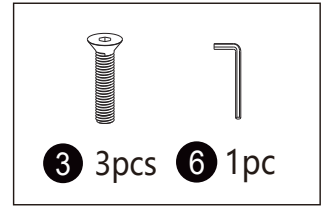
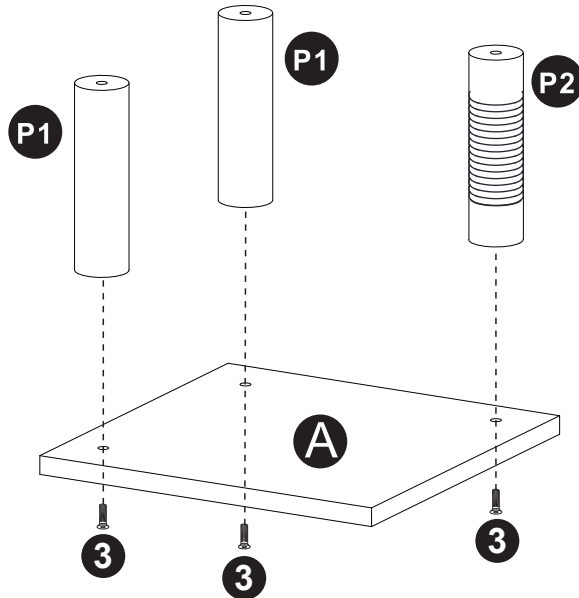

Align Pillar P1*2 and P2 with the holes in base Motherboard A.
Insert Screws ③*3 and tighten with Wrench ⑥.

Step 2

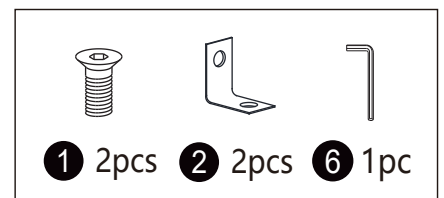
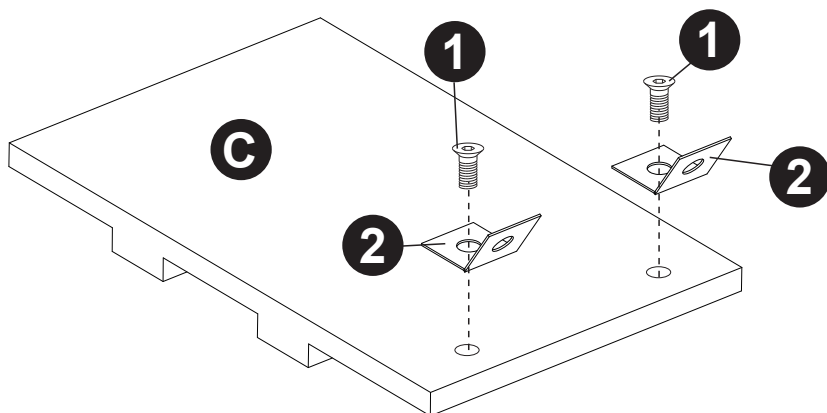

Use wrench ⑥ to secure the Angle Iron ②*2 to the back of the Stair Slabs C
with Screws ①*2.

Step 3

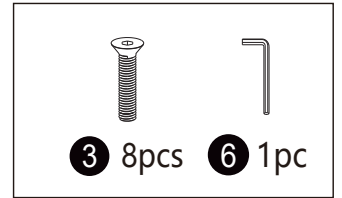
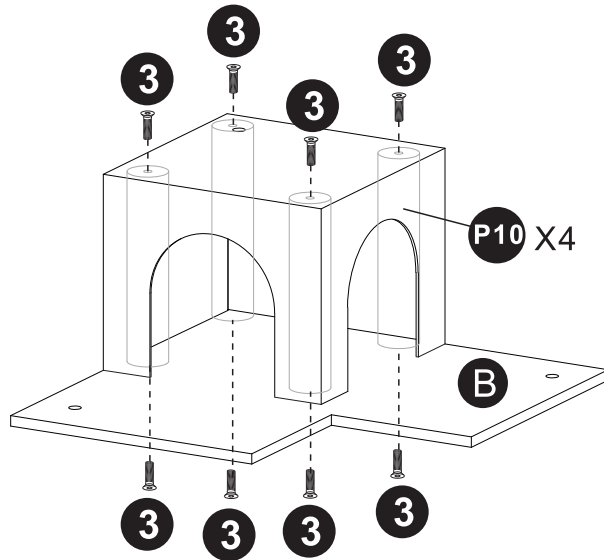

Place the Pillar P10*4 into the L-plate Kitten Litter B and align the holes, insert the Screws ③*8 into the post holes and tighten with Wrench ⑥.

NOTE: Align the Pillar with the hole on the far side.

Step 4

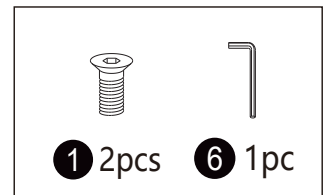
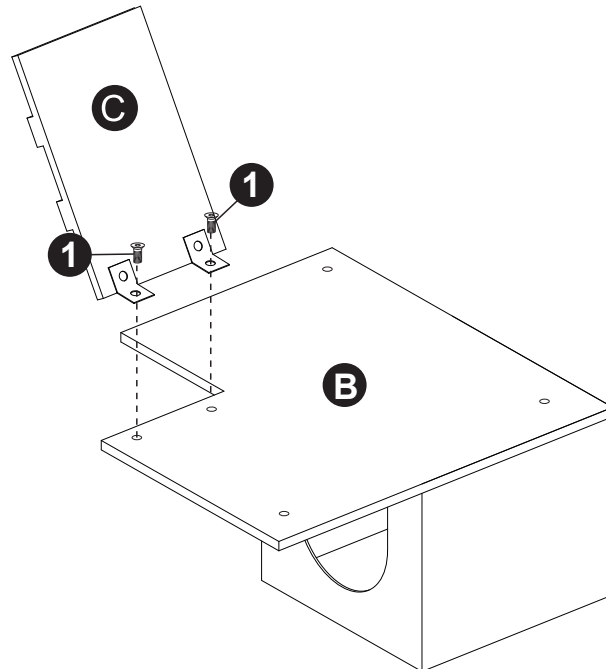

Connect the Stair Slabs C and the L-plate Kitten Litter B with Screws ①*2 and tighten them with Wrench ⑥.

Step 5

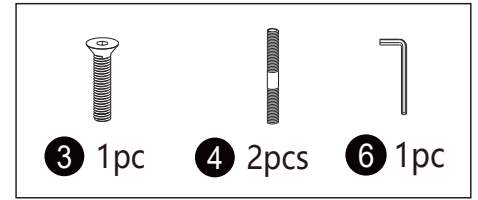
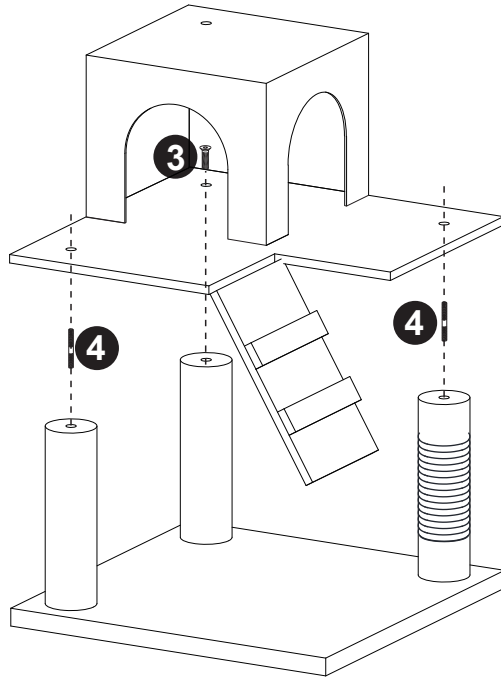

Connect the L-plate Kitten Litter B and the Pillar with Screws ③ and Screws ④*2 and tighten them with Wrench ⑥.

Step 6

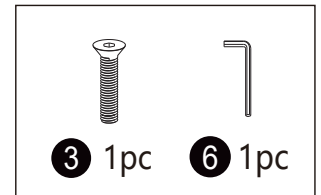
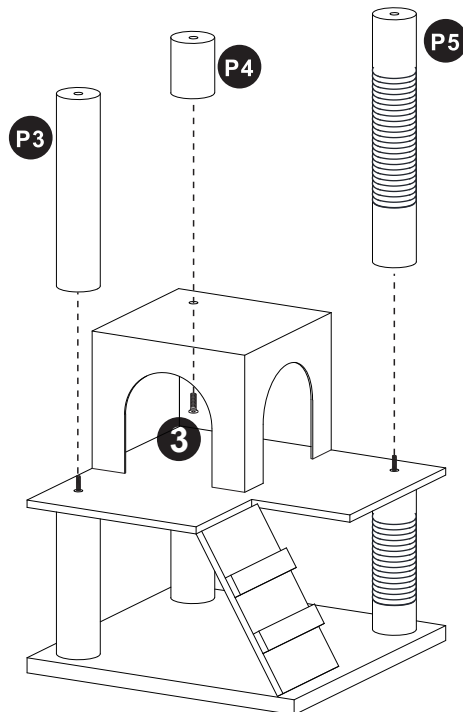

Attach Pillar P4 to the top of the L-plate Kitten Litter B with Screws ③ tighten with Wrench ⑥. Attach Pillar P5 and P3 to the remaining Screws ④*2 at the bottom of the top of the L-plate Kitten Litter.

Step 7

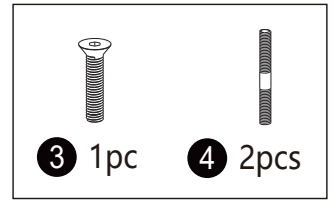
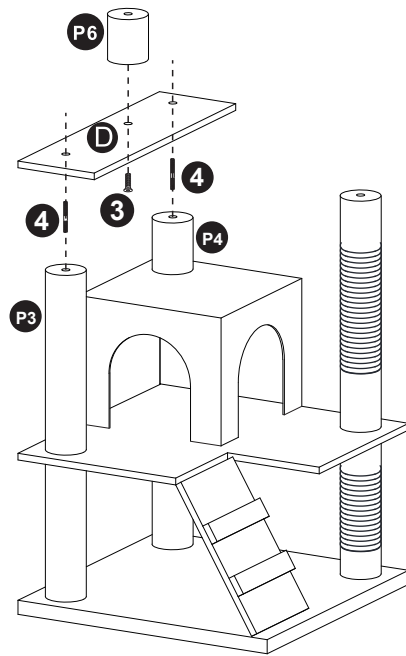

Tighten Slats D and Pillar P3 and P4 with Screws ④*2, and Pillar P6 with Screws ③.

Step 8

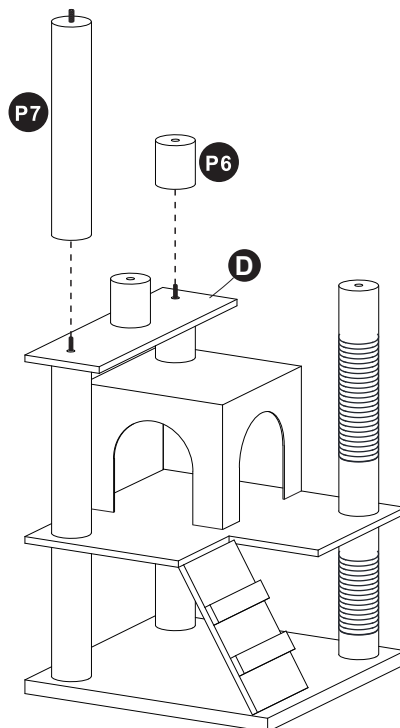

Tighten the remaining Screws ④*2 on both sides of the Slat D by putting Pillar P7 and P6.

Step 9

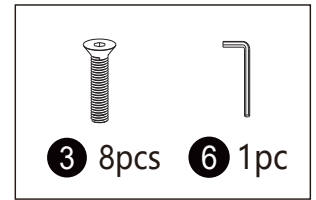
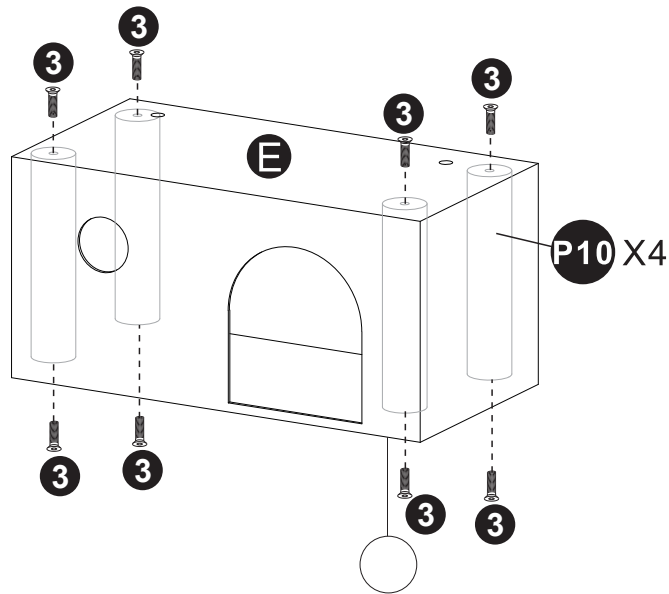

Place the Pillar P10*4 into the Big Cat Litter E and align the holes, insert the Screws ③*8 into the pillar holes and tighten with Wrench ⑥.

NOTE: Align the pillar to the hole on the far side.

Step 10

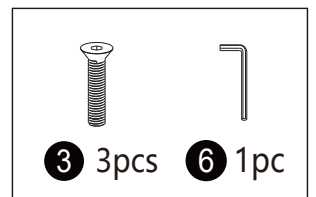
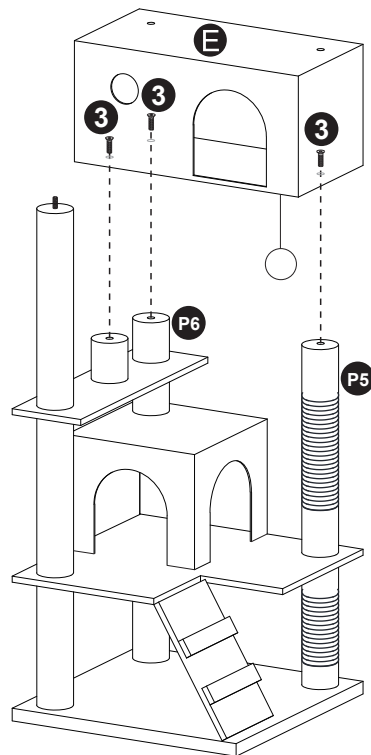

Thread the Screw ③*3 through the hole at the bottom of the Big Cat Litter E and Pillar P5 and P6*2 and tighten with Wrench ⑥.

Step 11

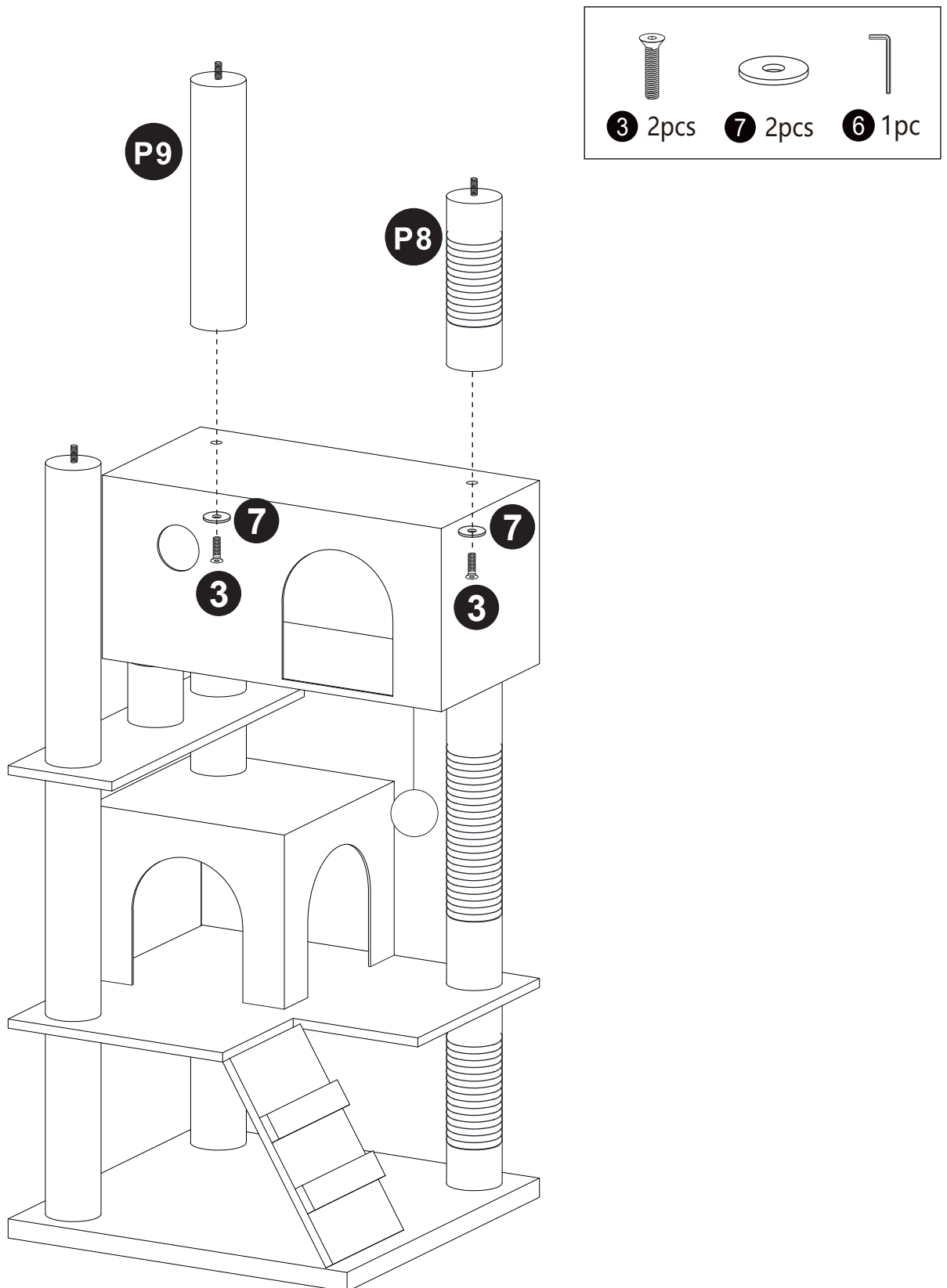

Thread the Screws③*2 and the Gasket⑦*2 through the holes at the top of the Big Cat Litter E and Pillar P8 and P9 and tighten them with Wrench ⑥.

Step 12

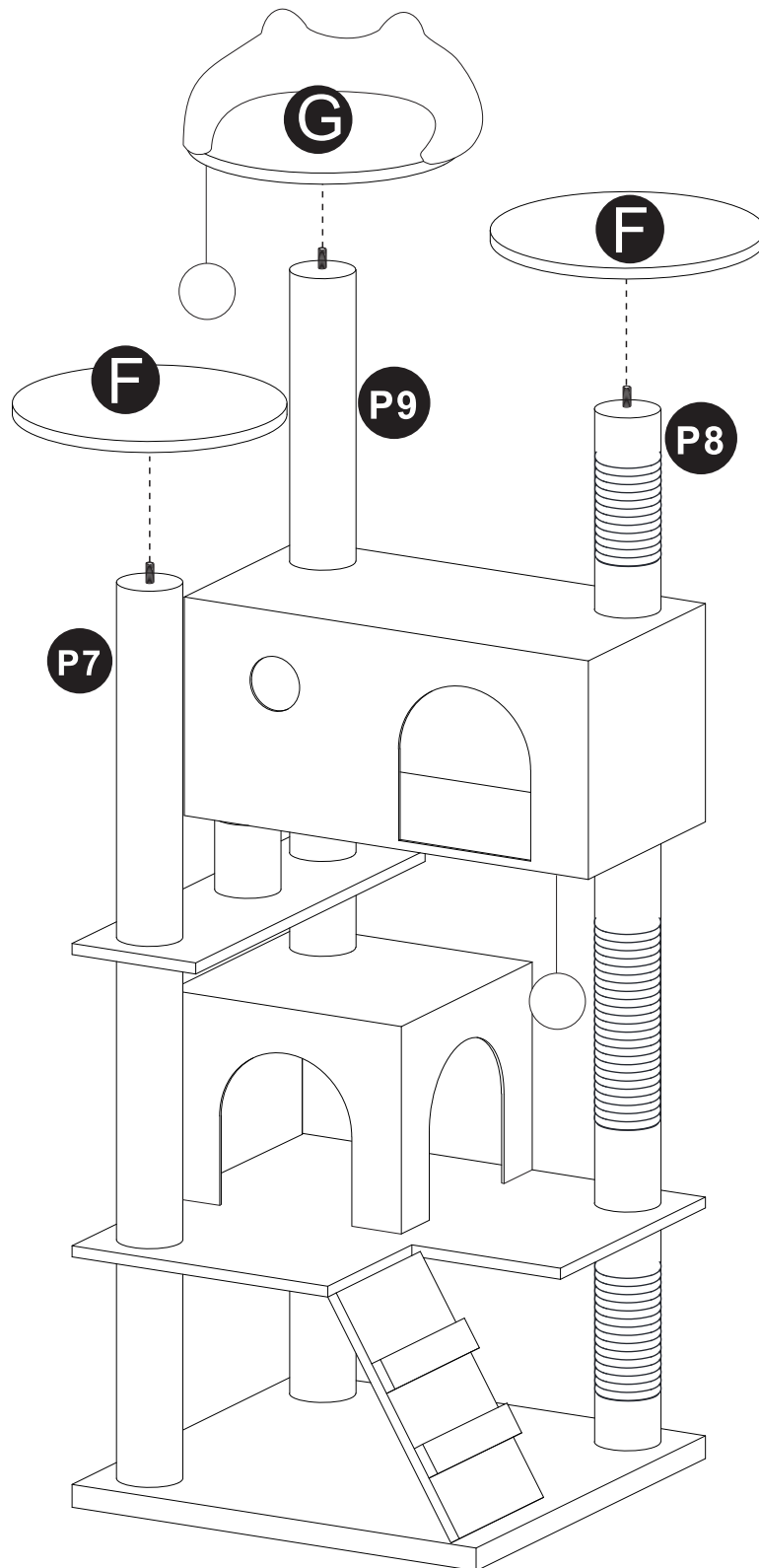

Rotate and tighten Round Plates F*2 and Round Plates Of Ears G and Pillar P7, P8, P9.

Step 13

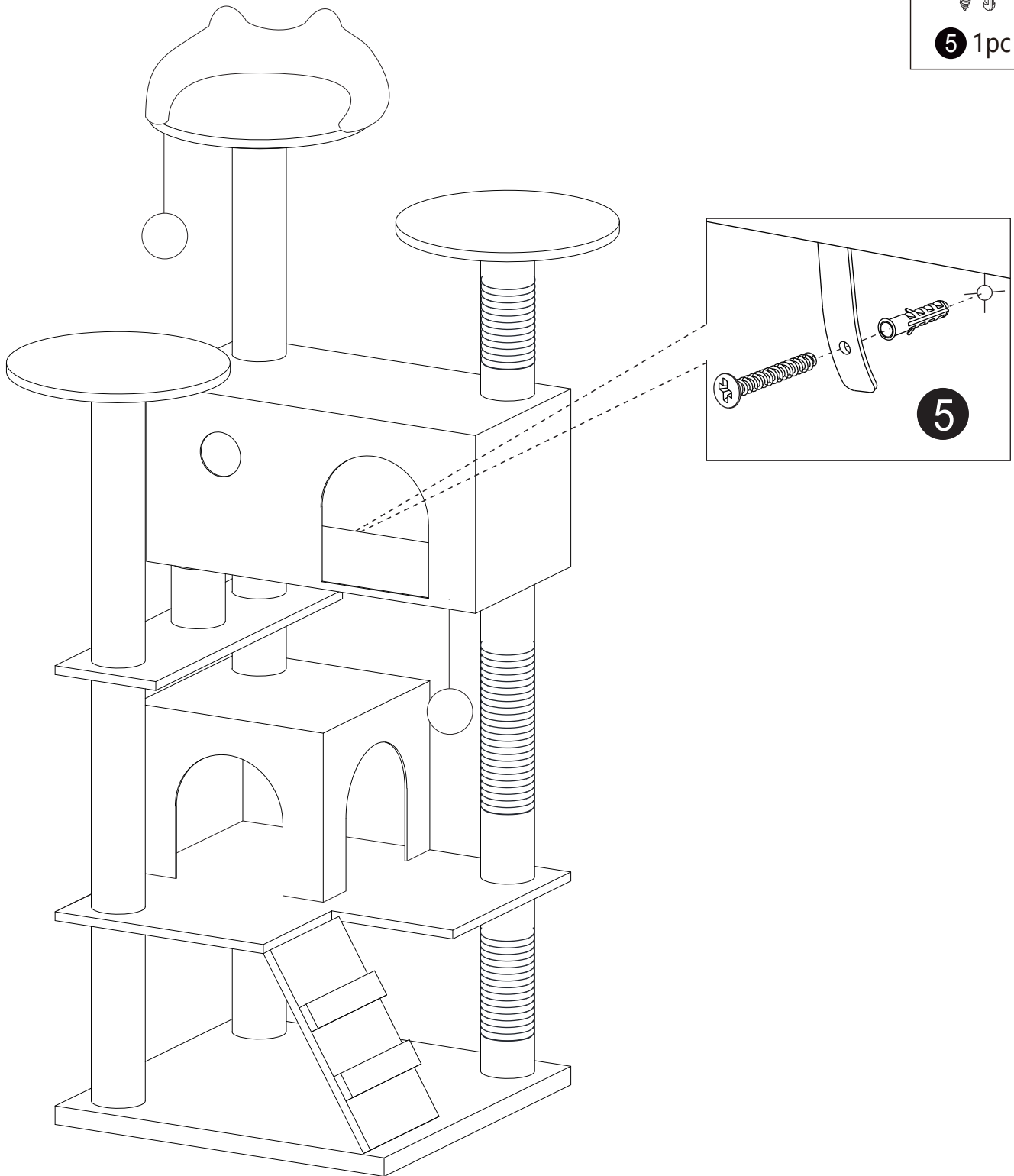
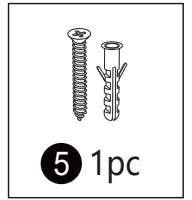

Fix the Expansion Screws ⑤ through the clips on the back of the Big Cat Litter E on the wall.

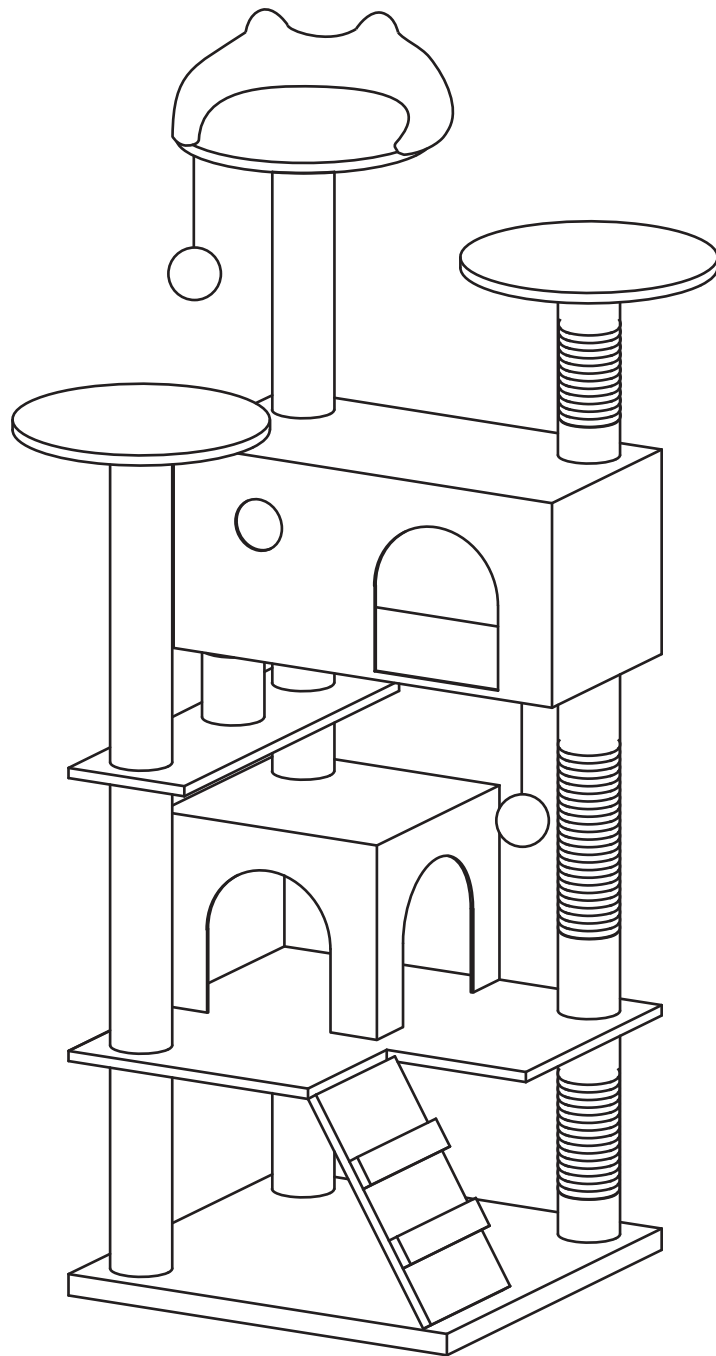

Thank you for choosing this product. We strive to provide you with the best quality products and services in the industry. Should you have any issues, please don't hesitate to contact us.