

To deodorize the leather leave the chair in a shady outside for 1-2 days.

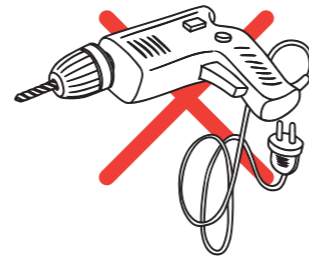

For longer use

Re-tighten bolts every 6 months by using the enclosed allen-key.
*Using an electric drill can damage the chair. Please re-tighten bolts manually.

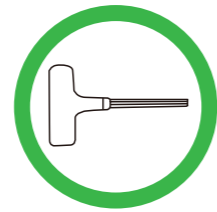

Safety Information



Sit in the center of the chair, with your back to the backrest



Do not sit at the front edge of the chair



Do not stand on the chair



Do not use the chair with more than one person



Do not push the chair around when a person is sitting in it



Do not push down on the backrest when a person is reclined



Do not place all your weight on only the backrest

INSTRUCTION MANUAL

Model: C-1025

✉ HJ-Customer-Service@outlook.com

☎ (909)637-7665 | (909)637-7593



INSTRUCTION MANUAL

C-1025

✉ HJ-Customer-Service@outlook.com

☎ (909)637-7665 | (909)637-7593

EST 9:00AM--17:00PM

Package List



(A)*1 Back



(B)*1 Cushion

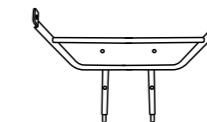

(C)*1 Iron Frame

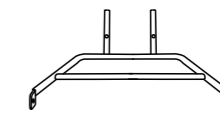

(D)*1 Iron Frame

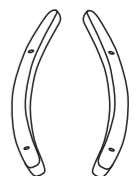

(E)*2 Wooden Foot



M6x20mm

(F)*4 Bolts



M6x30mm

(G)*4 Bolts



M8x50mm

(H)*2 Bolts



(I)*2 Shim



(J)*1 Wrench

Assembly Instruction

(A)*1 (B)*1 (H)*2
(I)*2 (J)*1

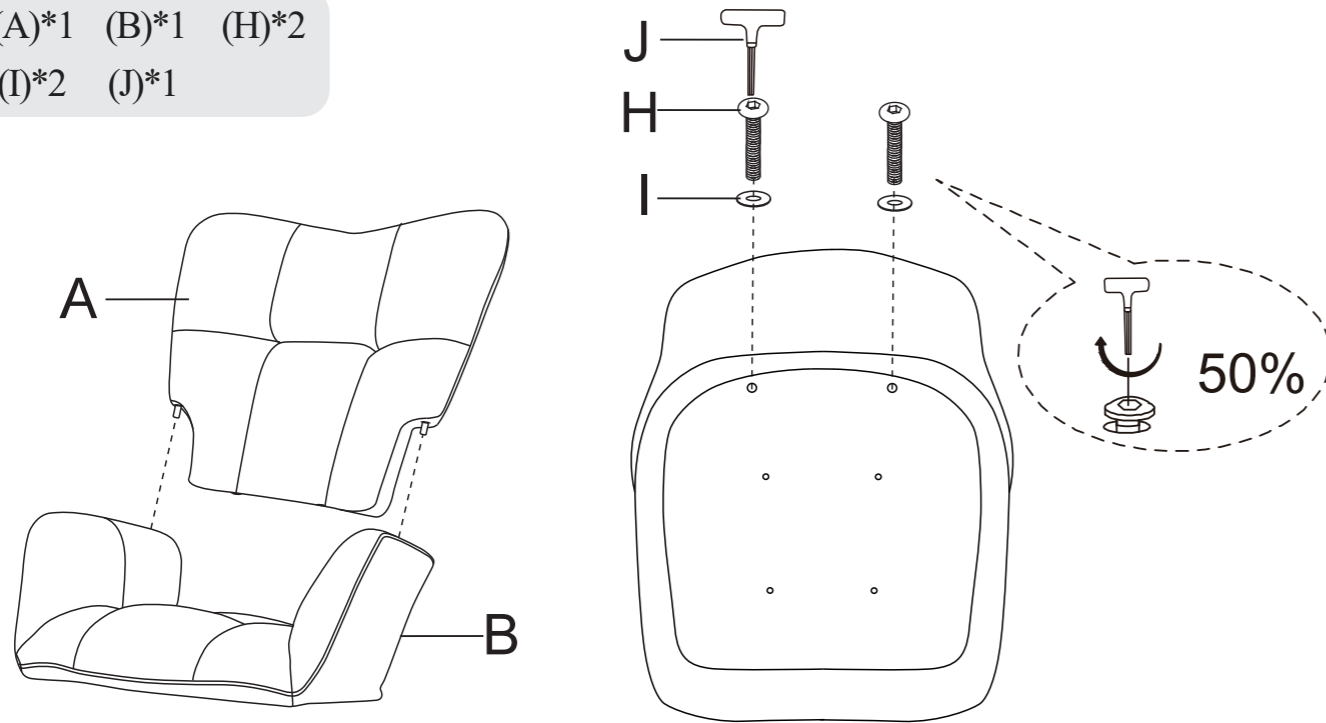

1 Please align and combine the backrest and seat cushion first.

(C)*1 (D)*1 (G)*4
(J)*1

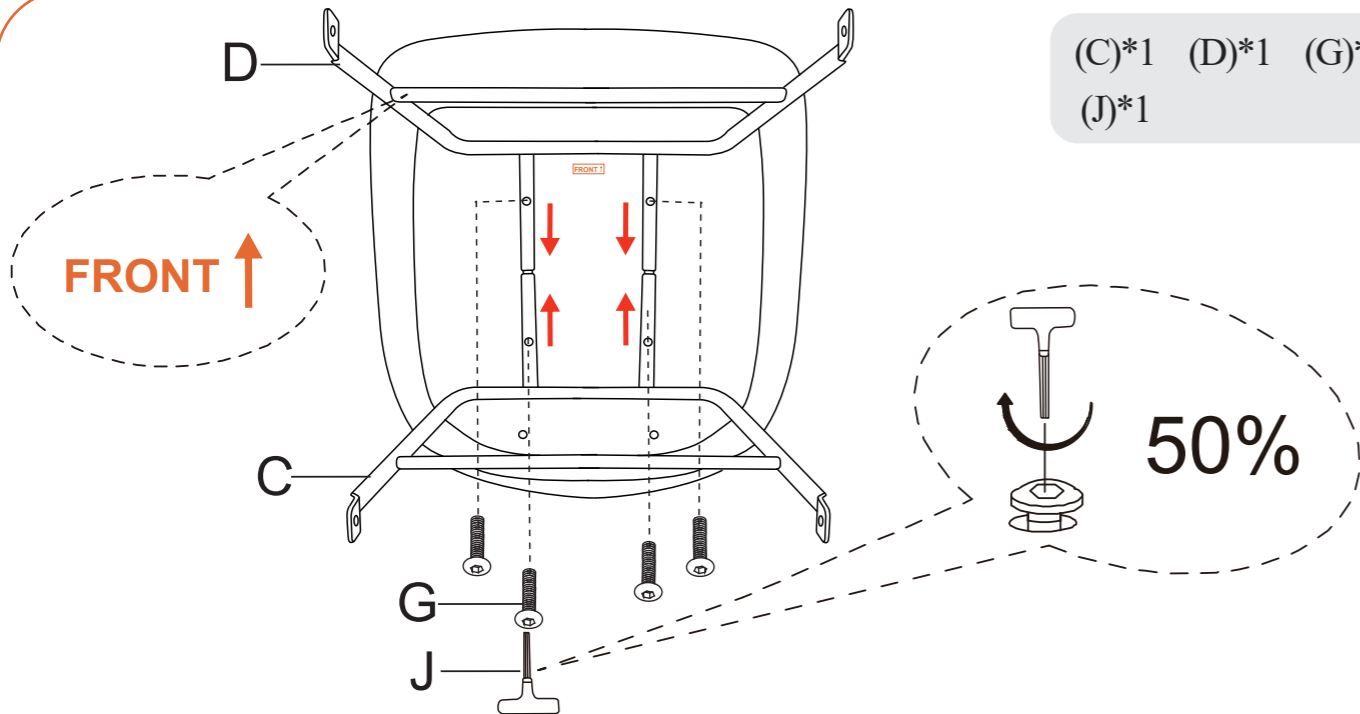

2 **NOTE:** When installing the iron frame to the bottom of the seat cushion, pay attention to distinguishing the front and rear positions of the iron frame, and there are front and rear labels attached to the iron frame.

(E)*2 (F)*4 (J)*1

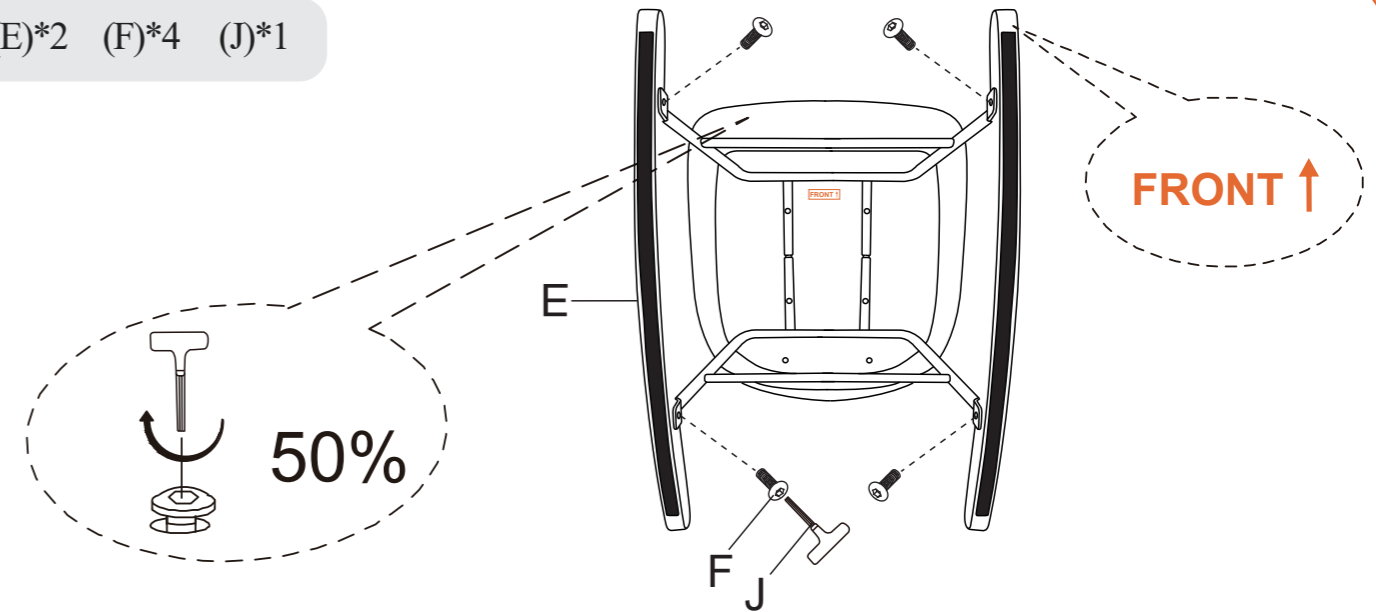

3 **NOTE:** When installing wooden feet, pay attention to distinguishing the front and rear directions, and there are front and rear labels attached to the wooden feet.

4

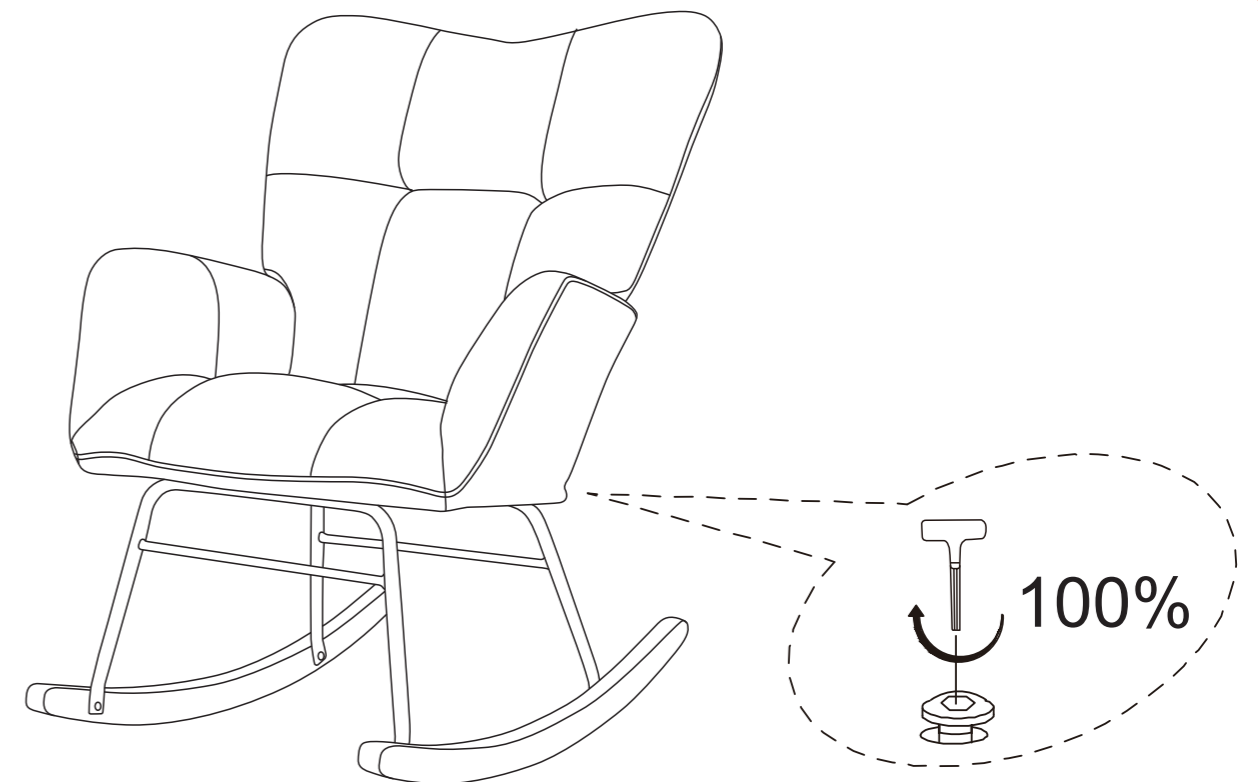

CAUTION:

- * Before using the chair, check to ensure that all bolts are fully tightened.
- * Lubricate all parts and tighten all bolts every 6 months or whenever needed.

NOTE: 1. All bolts are 100% tightened.