

To deodorize the leather
leave the chair in a shady
outside for 1-2 days.

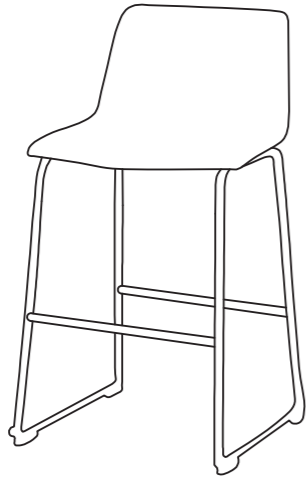

For longer use

Re-tighten bolts every 6 months by using
the enclosed allen-key.
*Using an electric drill can damage the chair.
Please re-tighten bolts manually.

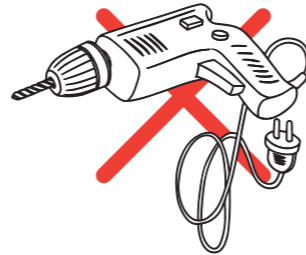
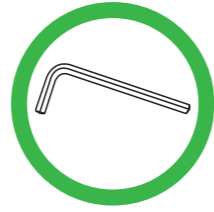

Safety Information



Sit in the center of the
chair, with your back to
the backrest



Do not sit at the front
edge of the chair



Do not stand on the
chair



Do not use the chair
with more than one
person



Do not push the chair
around when a person
is sitting in it



Do not push down on
the backrest when a
person is reclined



Do not place all your
weight on only the
backrest

INSTRUCTION MANUAL

Model: C-6014

✉ HJ-Customer-Service@outlook.com

☎ (909)637-7665 | (909)637-7593

INSTRUCTION MANUAL

C-6014

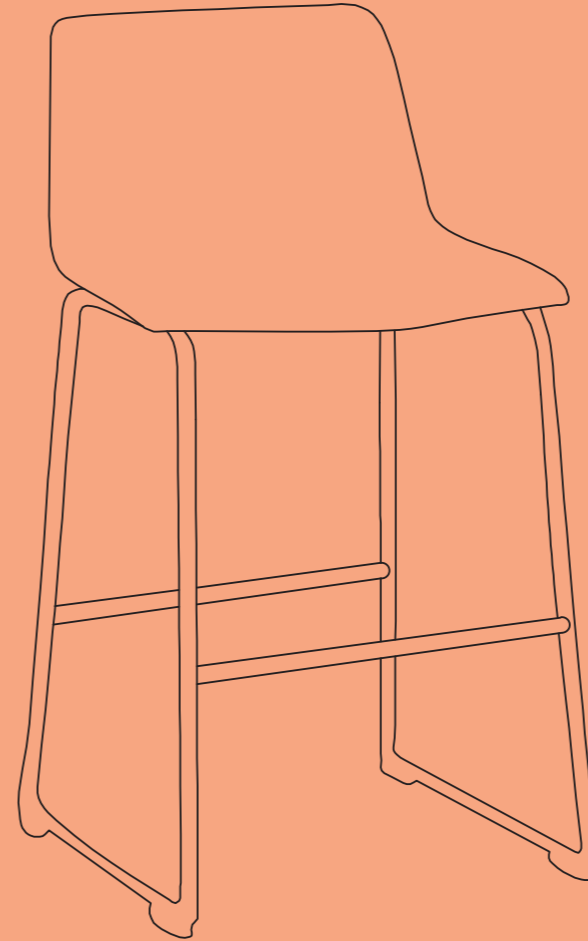

✉ HJ-Customer-Service@outlook.com

☎ (909)637-7665 | (909)637-7593

EST 9:00AM--17:00PM

Package List



(A)*1 Seat



(B)*1 (R) Leg

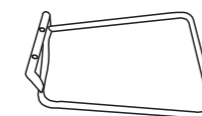

(C)*1 (L) Leg



(D)*2 Round Tube



M6x25mm

(E)*4 Bolts



M8x14mm

(F)*2 Bolts

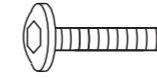

M6x22mm

(G1)*2 Bolts

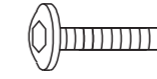

M6x22mm

(G2)*2 Bolts

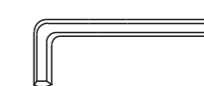

(H)*1 Wrench



(I)*1 Wrench

Assembly Instruction

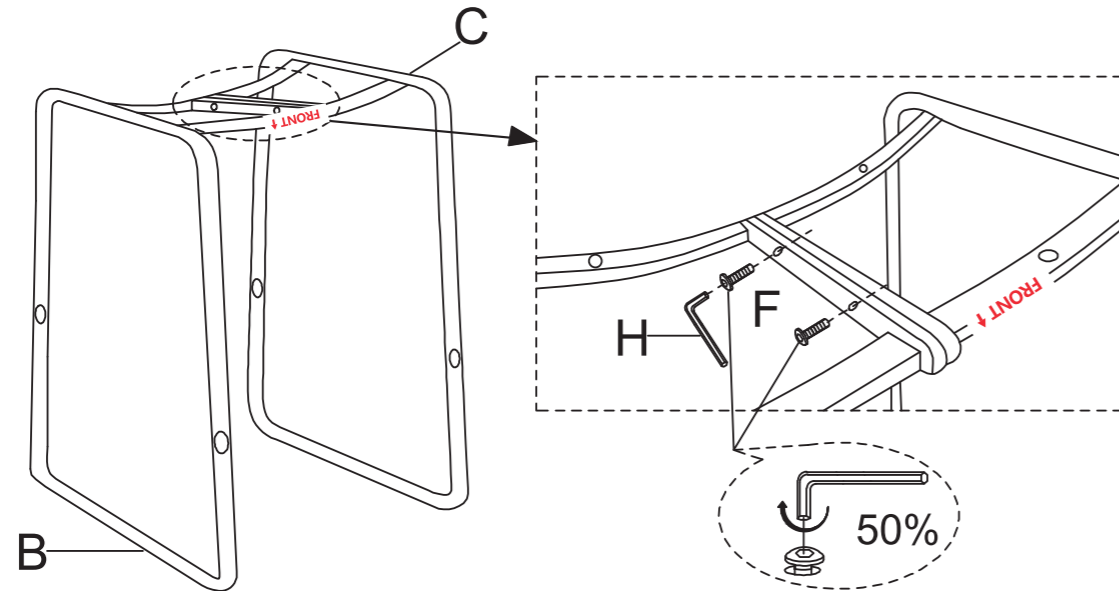

1

Fix the Leg **(B)*1(R)** and **(C)*1(L)** with Bolts **(F)*2**.

Note: Bolts are only tightened **50%**. Make sure the "FRONT" on the Leg is mounted correctly.

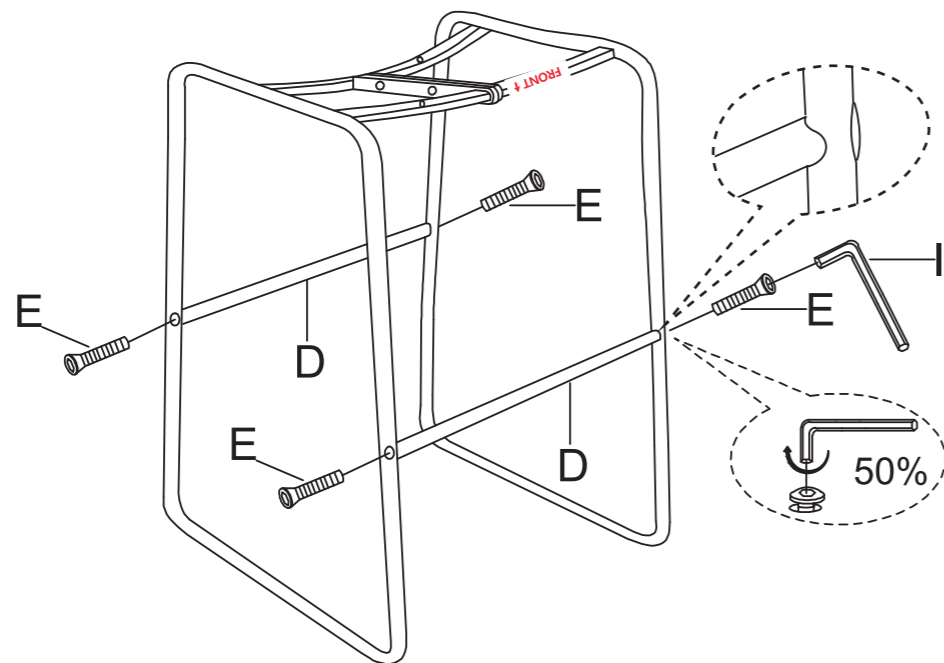

2

Install Round Tube **(D)*2** to the Legs **(B&C)** with Bolts **(E)*4**.

Note: Bolts are only tightened **50%**. The **grooves** of the Round Tube fit the Legs.

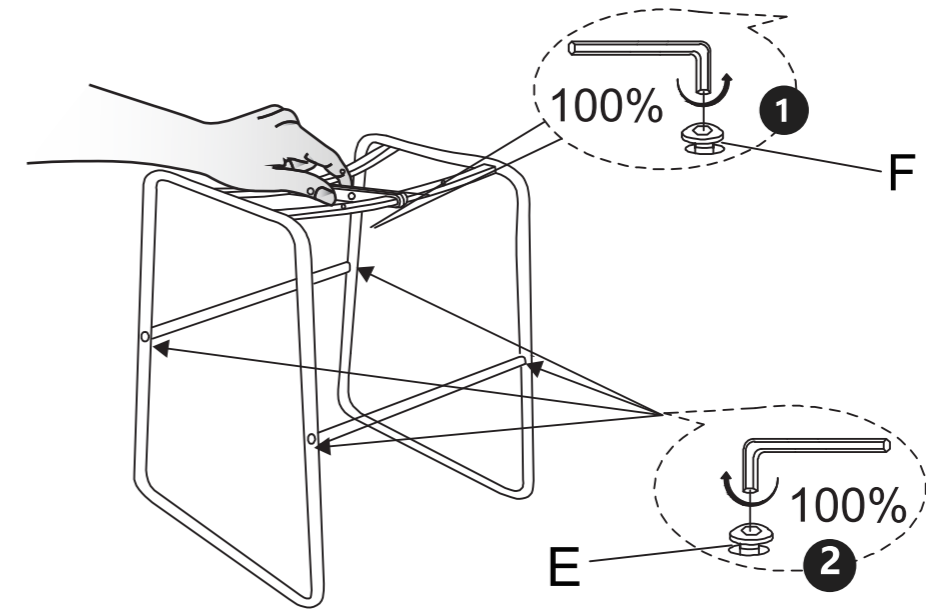

3

Adjust the connection between legs **(B)** and **(C)** to make it flat. Then, 100% tighten the Bolts in the order shown. **F→E**

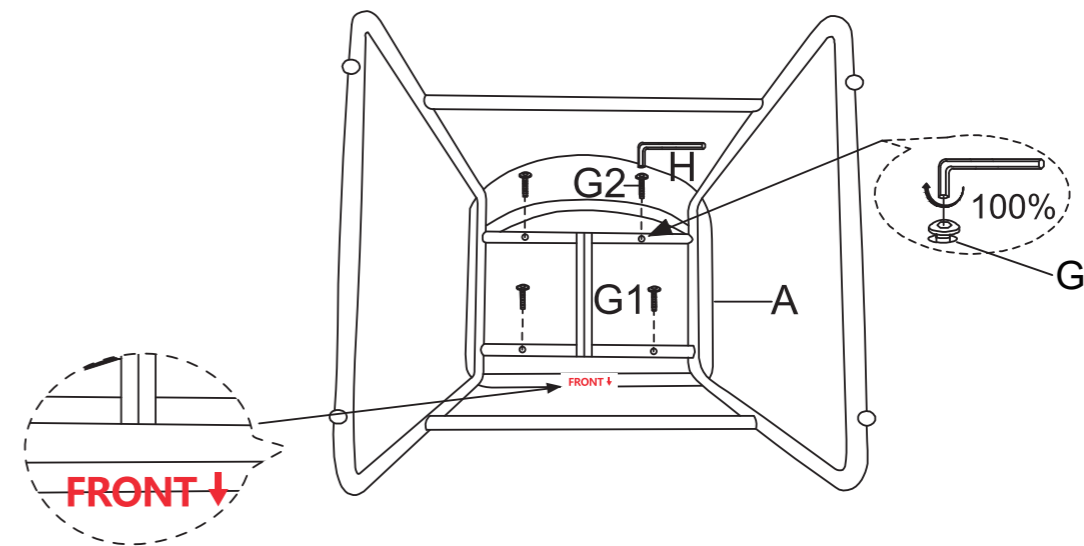

3

Place the Seat **(A)** face down. Attach Legs **(B&C)** to the Seat **(A)** with Bolts **(G1)*2** and **(G2)*2** and 100% tighten the Bolts.

Note: Make sure the "FRONT" on the Seat and Legs are the same direction.

CAUTION:

- * Before using the chair, check to ensure that all bolts are fully tightened.
- * Lubricate all parts and tighten all bolts every 6 months or whenever needed.