

ASSEMBLY INSTRUCTION

PLEASE READ BEFORE ASSEMBLING!

Tip #1: Make sure you've taken all the pieces and hardware out of its packaging before discarding the box. Assembly on top of flattened box/blanket is recommended.

Tip #2: Using page 2 and/or page 3 of instruction manual make sure all pieces and hardware are accounted for.

Tip #3: Note position of all holes on each panel during assembly.

ITEM#: 27090、 29283、 161552、 161774

Need some help?
Scan here for
assembly video.

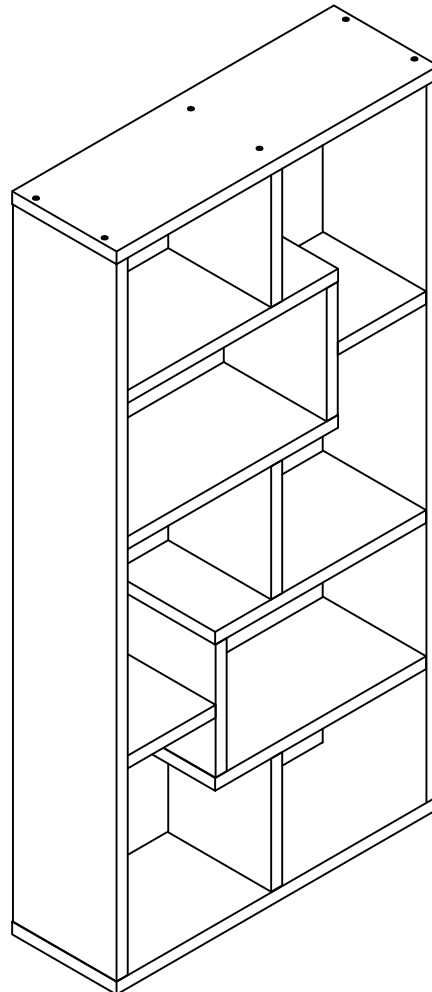

PARTS IDENTIFICATION



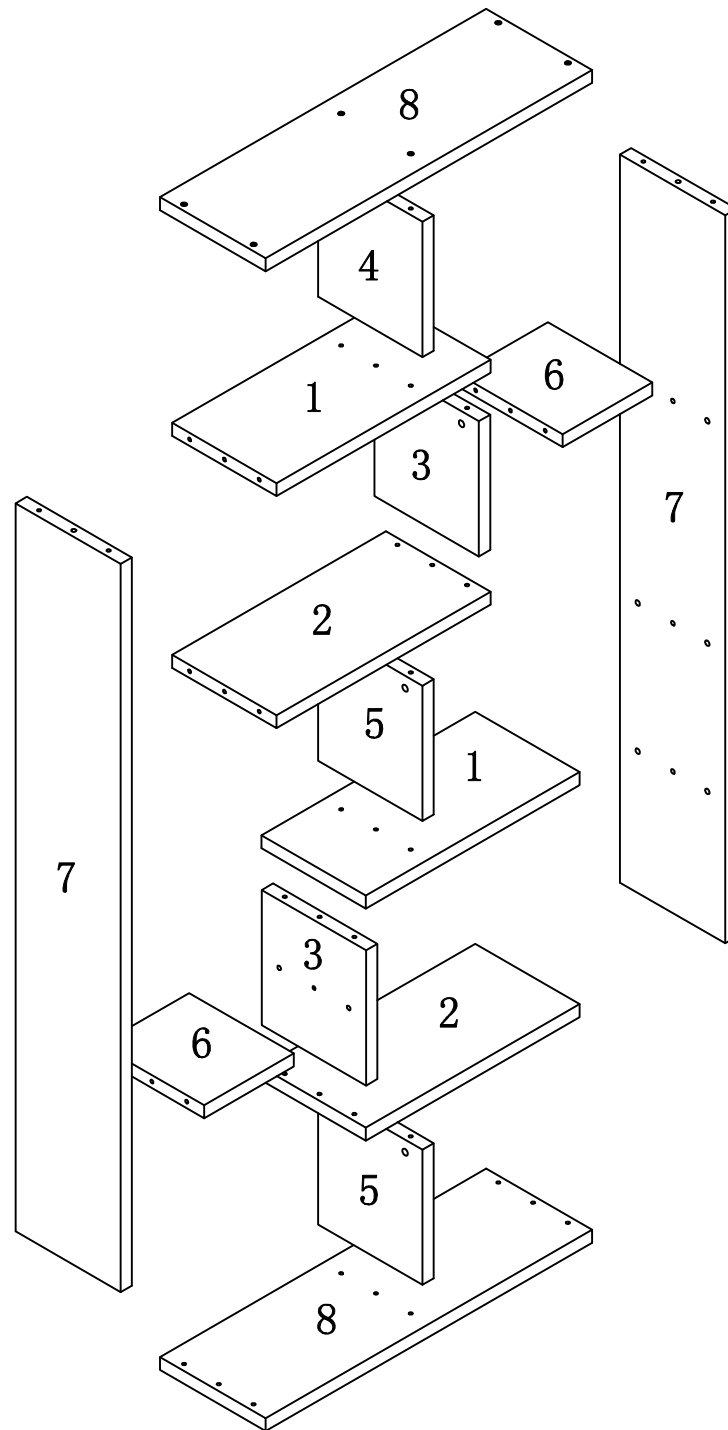



ITEM#: 27090、 29283、 161552、 161774

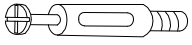

- | | |
|-----|------|
| (1) | 2pcs |
| (2) | 2pcs |
| (3) | 2pcs |
| (4) | 1pc |
| (5) | 2pcs |
| (6) | 2pcs |
| (7) | 2pcs |
| (8) | 2pcs |

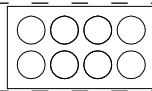
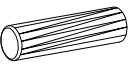

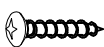
HARDWARE IDENTIFICATION

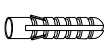
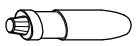
ITEM#: 27090、29283、161552、161774

A		L29mm	24pcs
B		∅15mm	24pcs
C		∅7x58mm	20pcs
D		∅20mm	44pcs
E		∅8x25mm	22pcs
F		197×5×1mm	1pc
G		12×12×1mm	2pcs
H		∅4x25mm	1pc
I		∅5x40mm	1pc
J		∅8x40mm	1pc
K		Glue: For securing please apply to wood dowel first before inserting into panel	1pc

ASSEMBLY INSTRUCTION

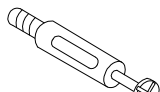
ITEM#: 27090、29283、161552、161774

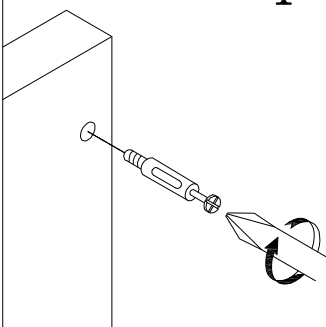
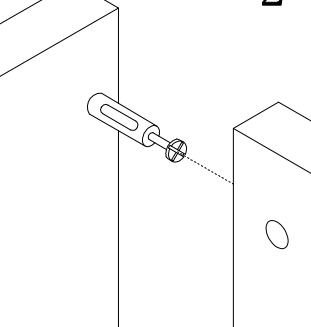
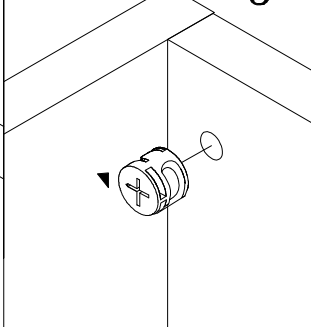
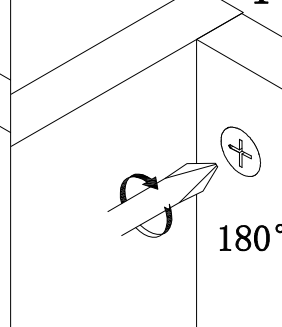
<p>HOW TO</p>  <p>Cam Bolt</p>  <p>Cam Lock</p>	1	2	3	4
	 <p>1. Screw Cam Bolt into panel.</p>	 <p>2. Insert Cam Bolt into bolt hole of joining panel.</p>	 <p>3. Insert Cam Lock. arrow facing bolt.</p>	 <p>4. Gently turn Cam Lock clockwise to lock position.</p>

ASSEMBLY INSTRUCTION

ITEM#: 27090、29283、161552、161774

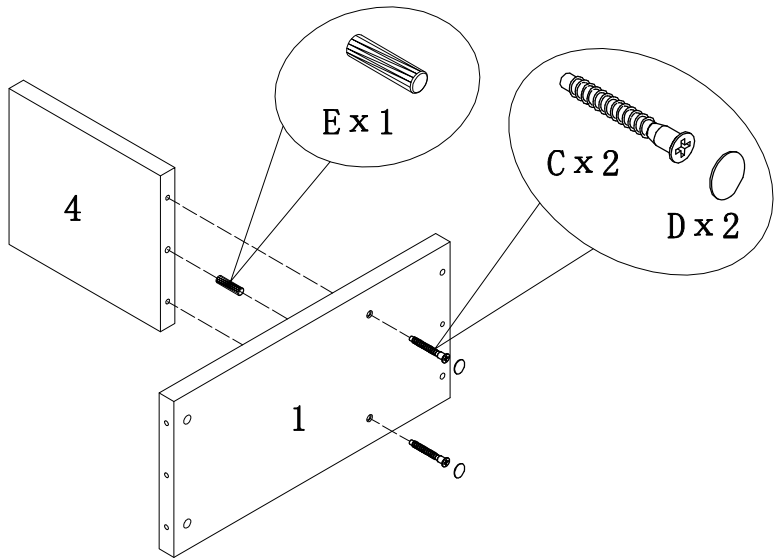

STEP 2

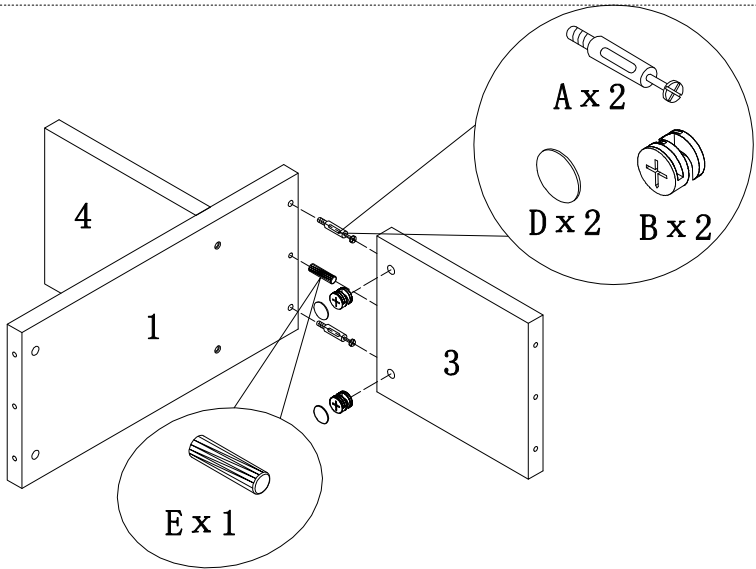

STEP 3

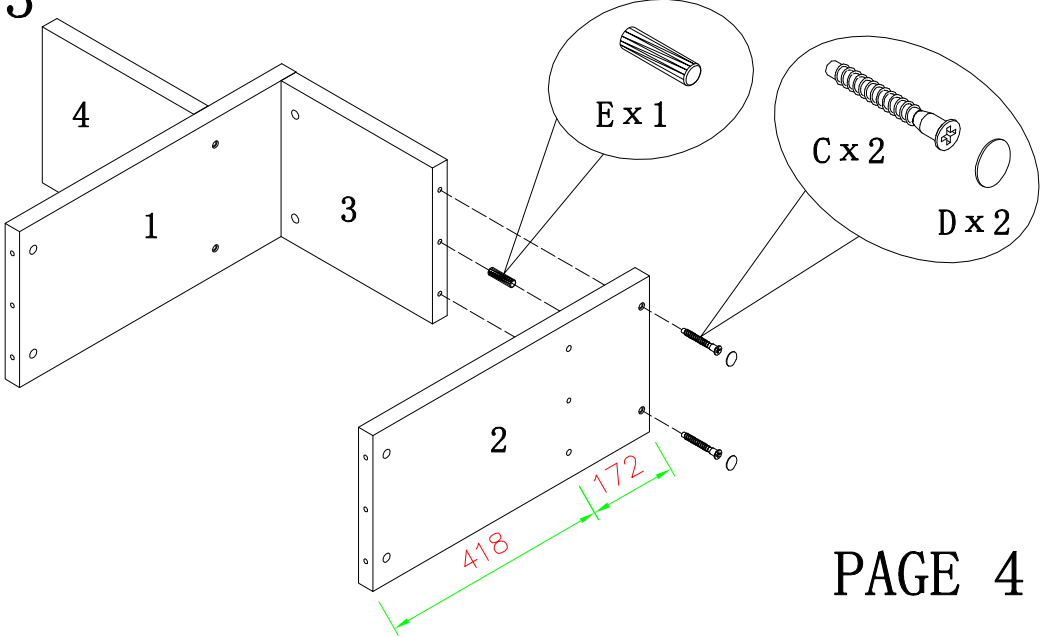

ASSEMBLY INSTRUCTION

ITEM#: 27090、29283、161552、161774

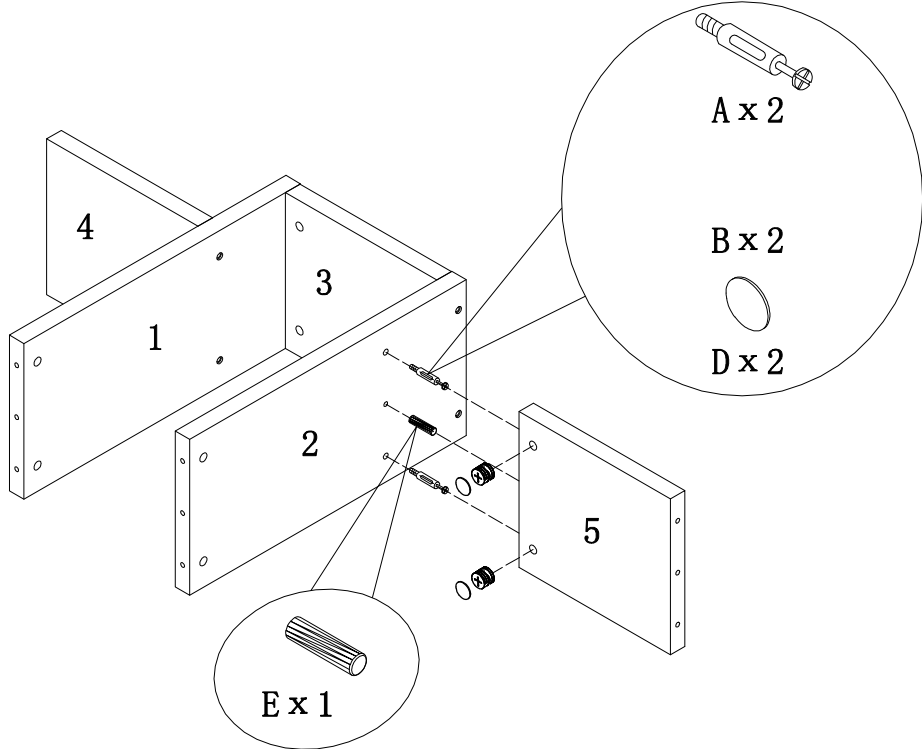

STEP4

STEP5

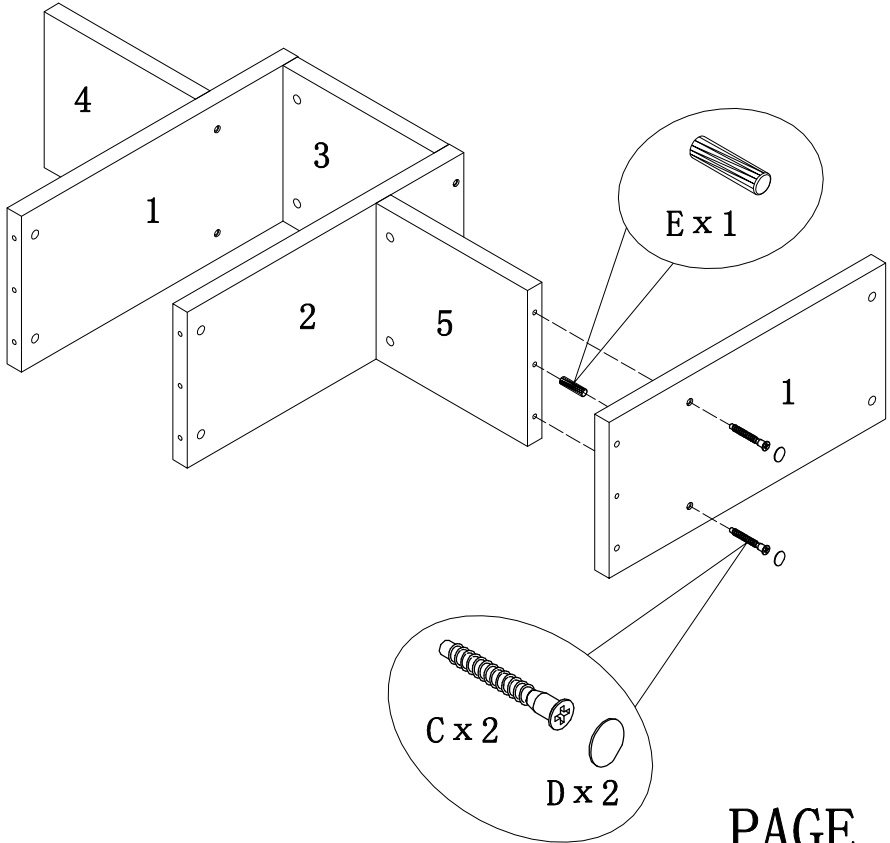

ASSEMBLY INSTRUCTION

ITEM#: 27090、29283、161552、161774

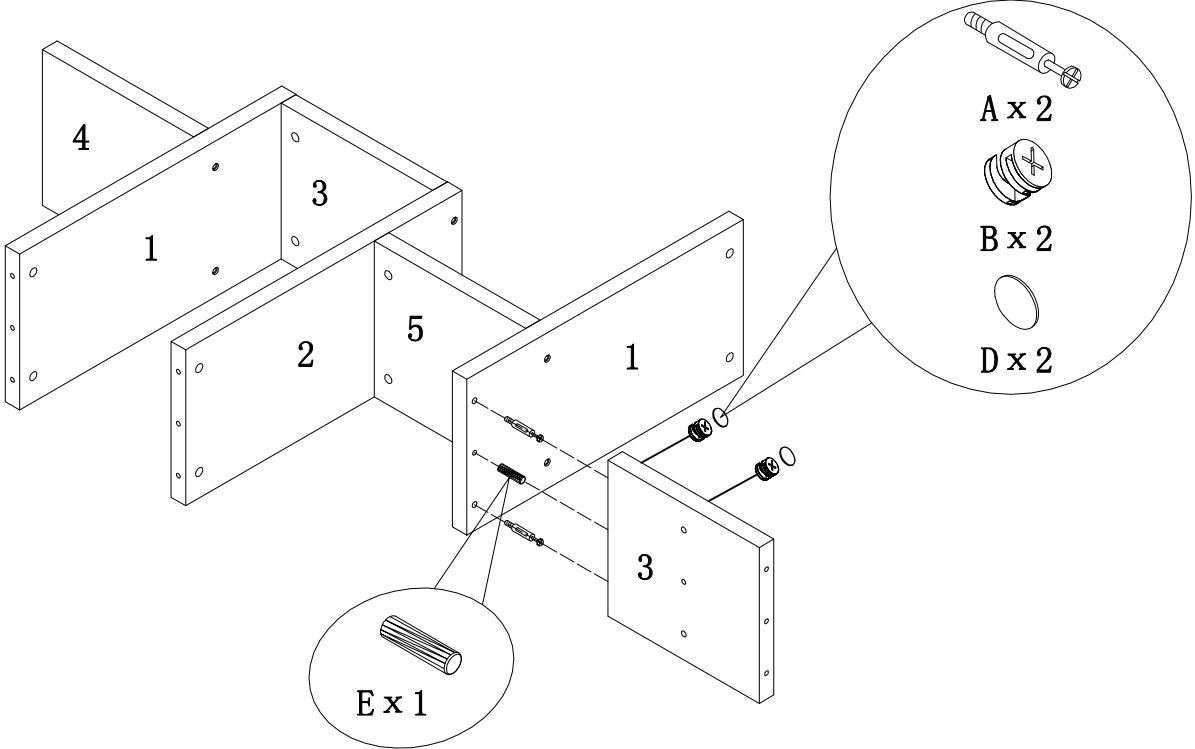

STEP6

STEP7

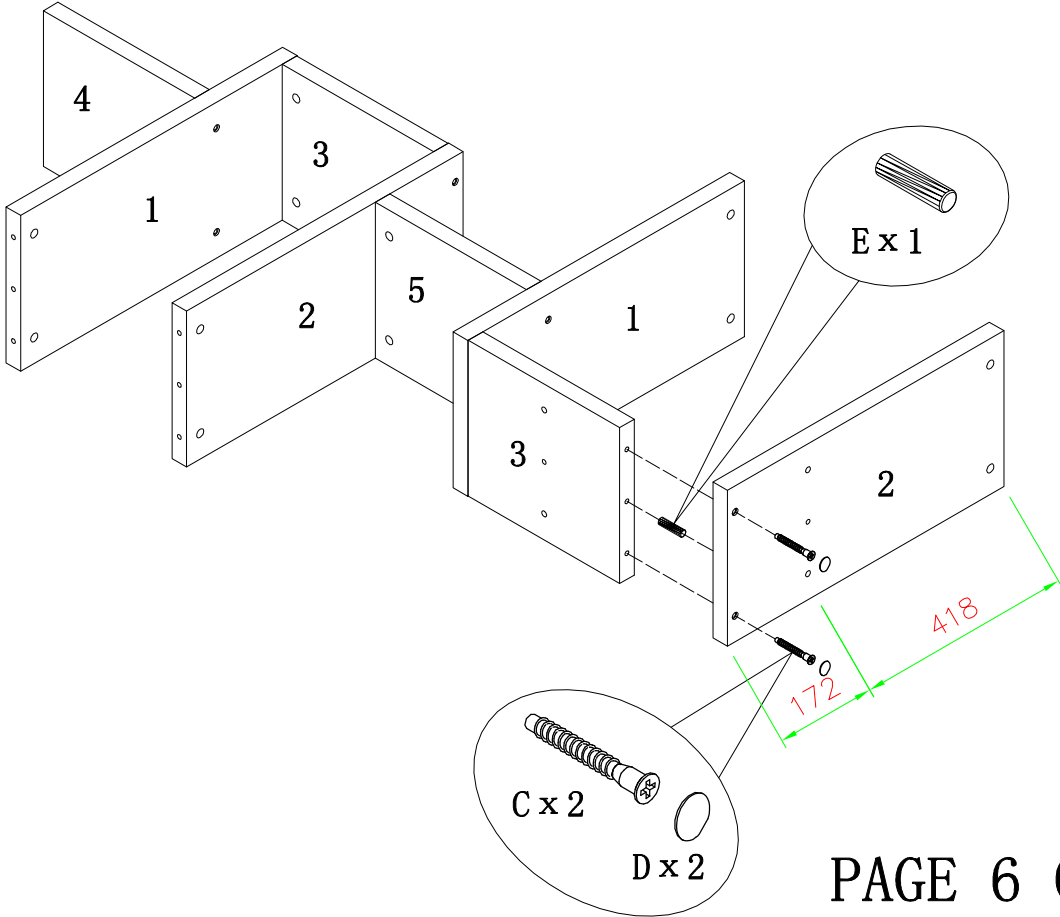

ASSEMBLY INSTRUCTION

ITEM#: 27090、29283、161552、161774

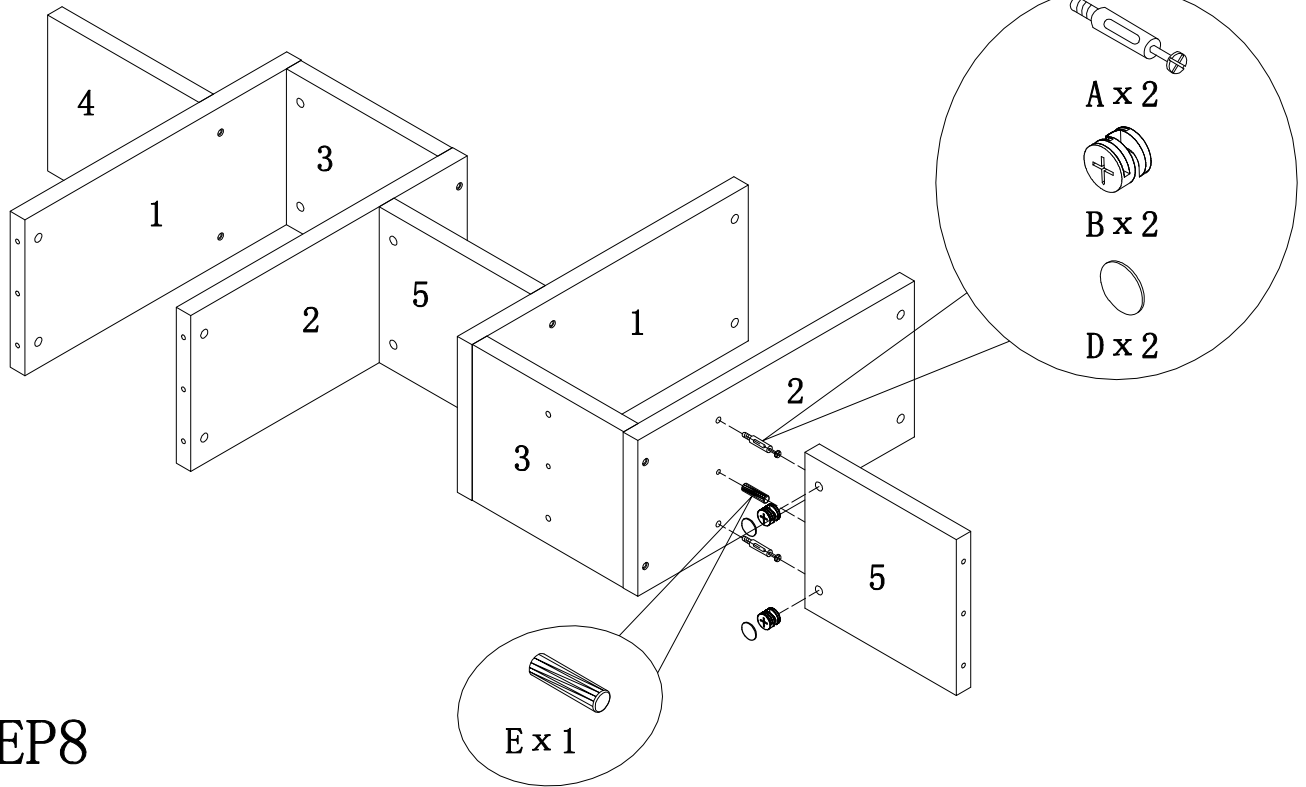

STEP 8

STEP 9

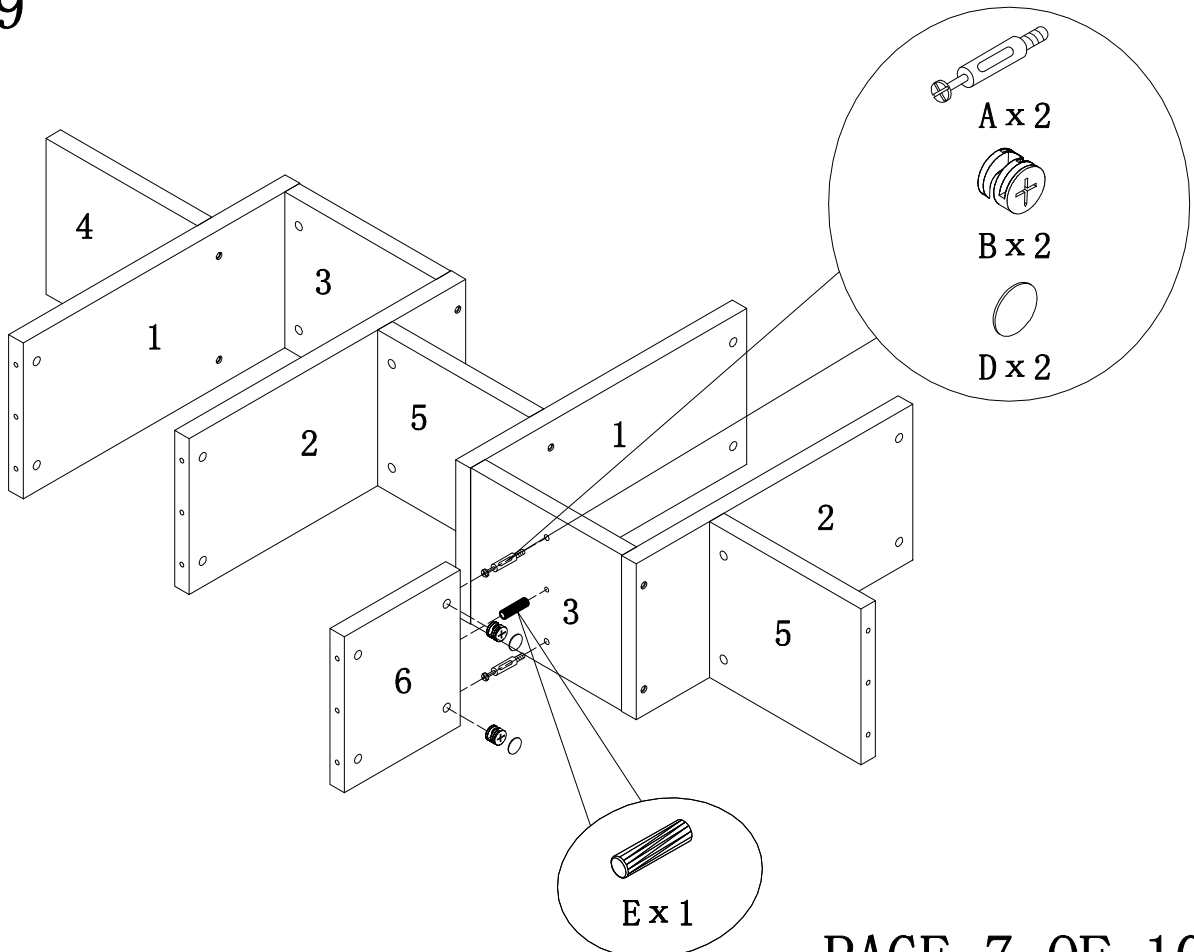

ASSEMBLY INSTRUCTION

ITEM#: 27090、29283、161552、161774

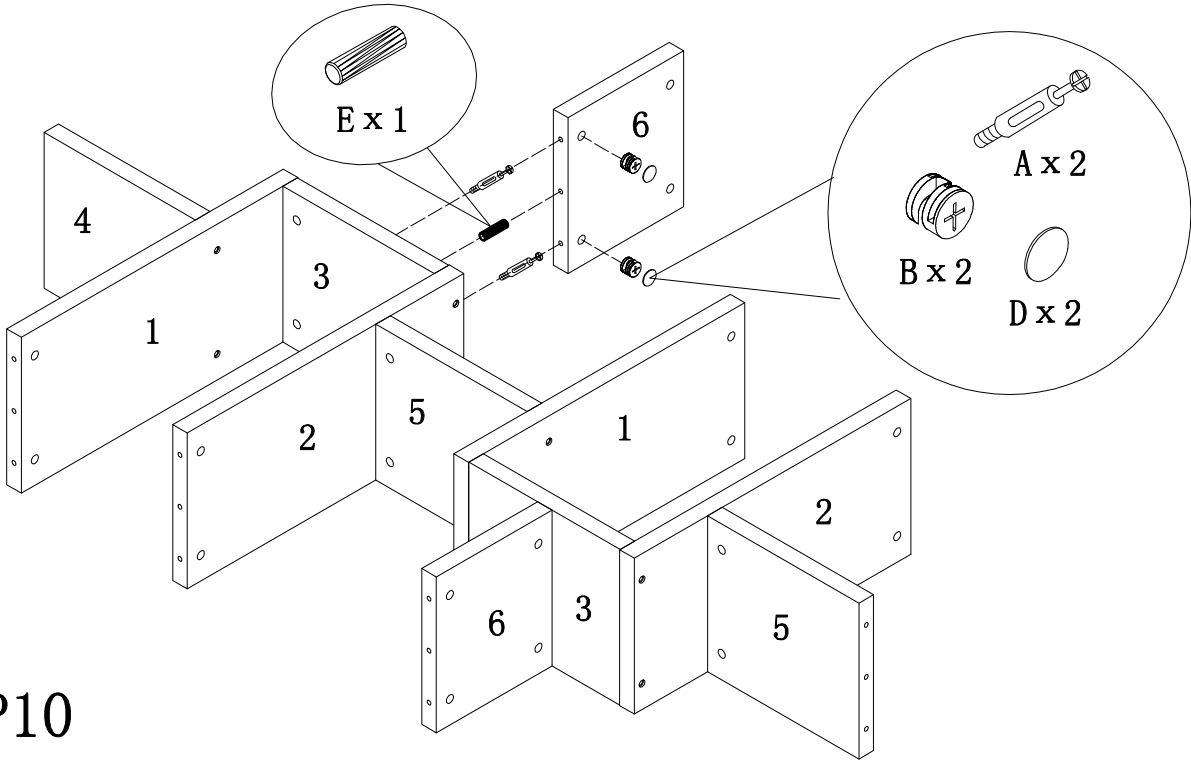

STEP 10

STEP 11

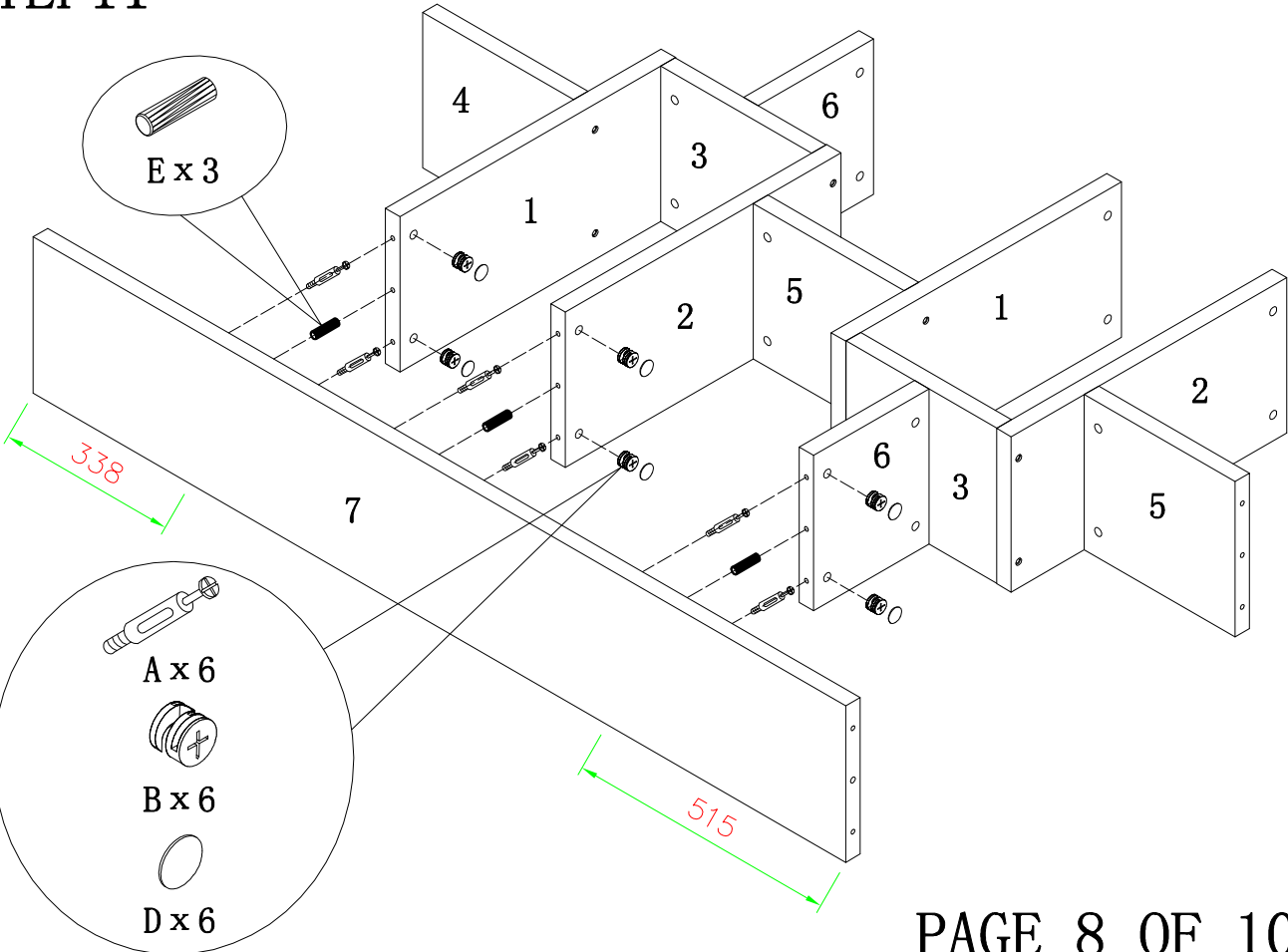

ASSEMBLY INSTRUCTION

ITEM#: 27090、29283、161552、161774

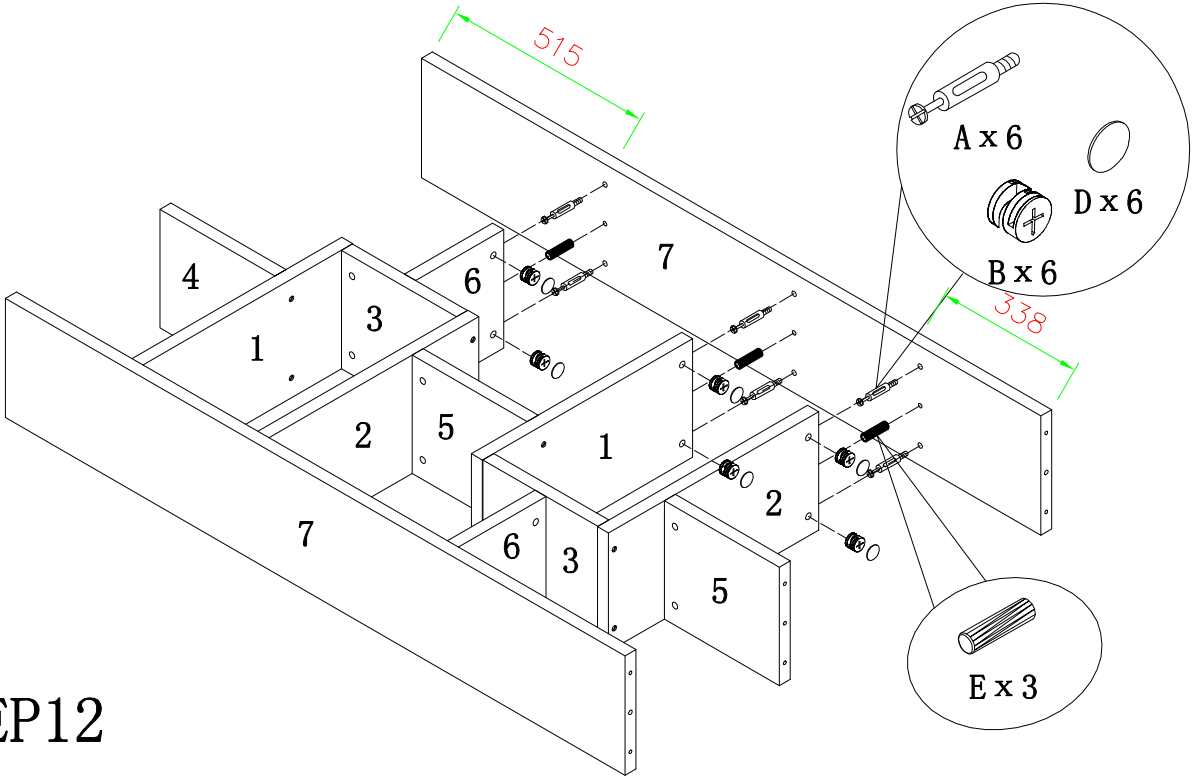

STEP 12

STEP 13

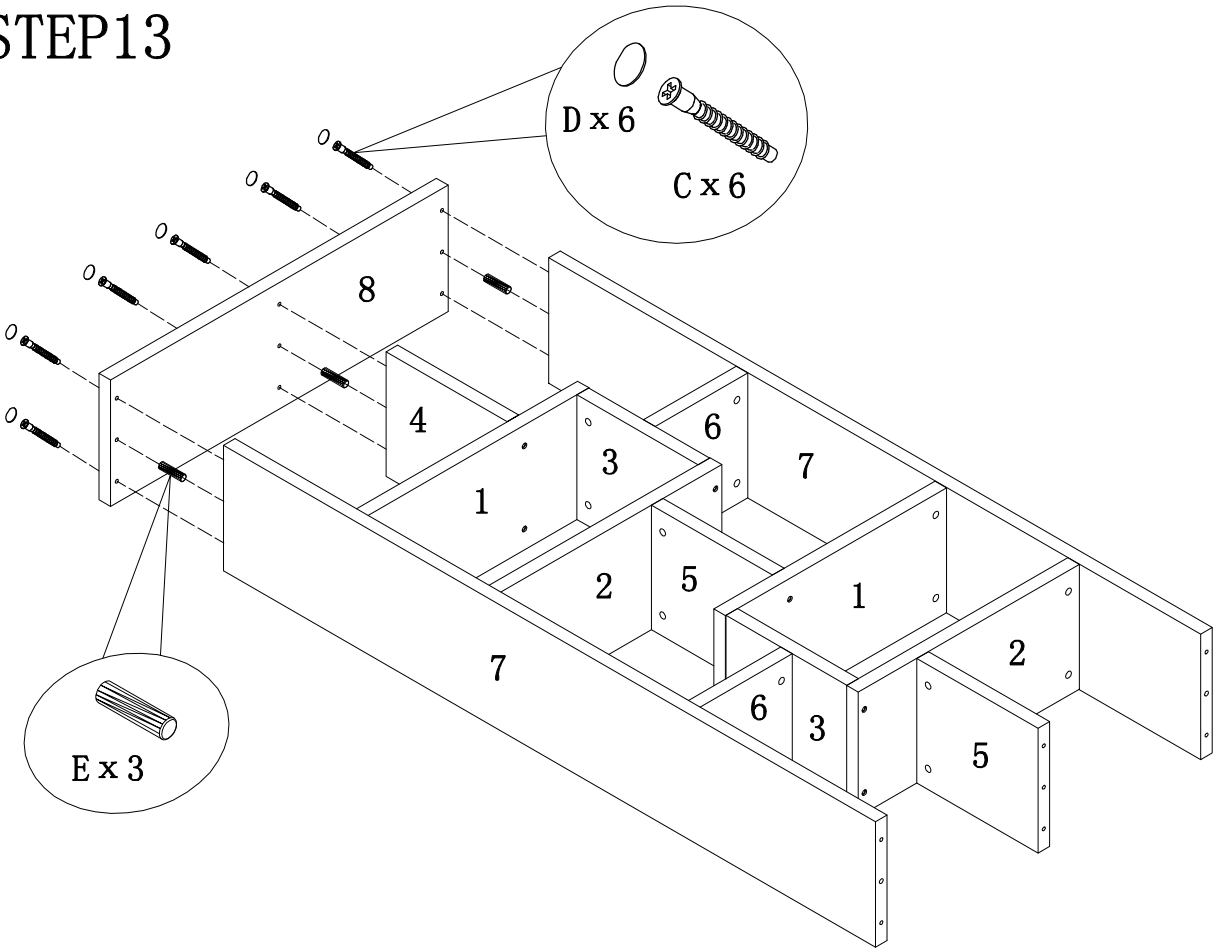

ASSEMBLY INSTRUCTION

ITEM#: 27090、29283、161552、161774

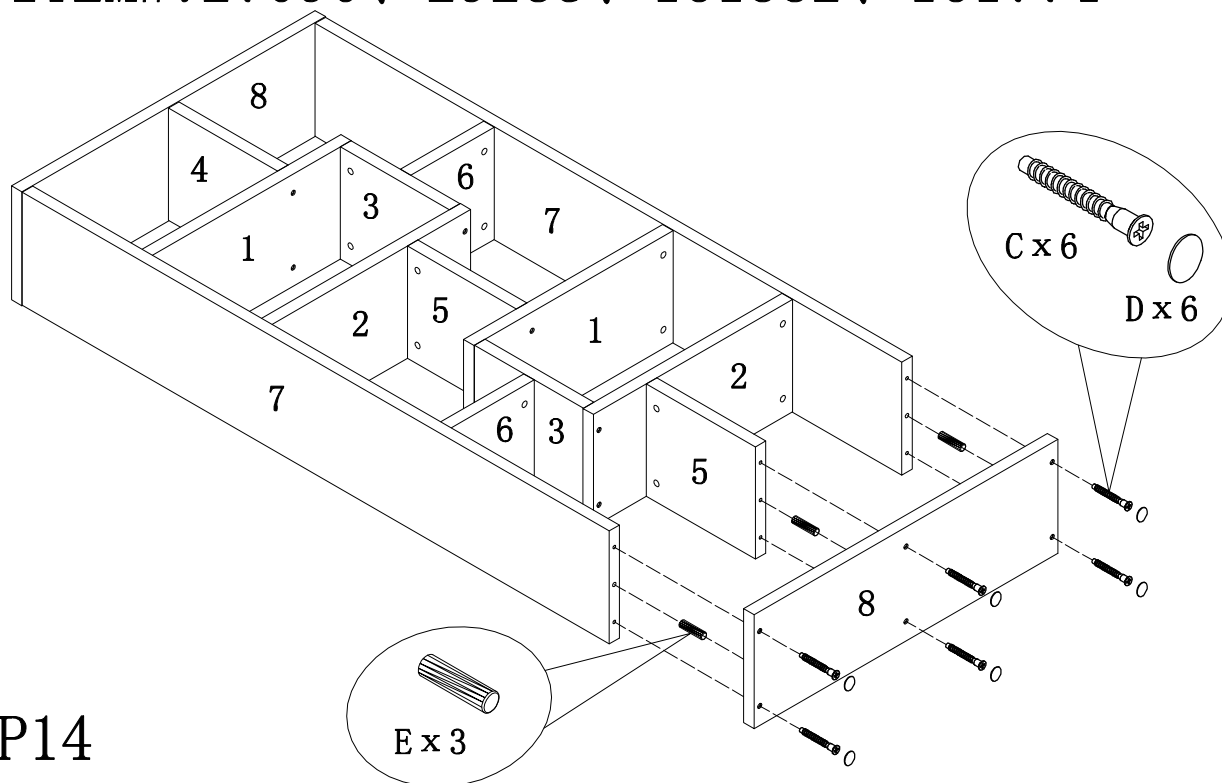

STEP 14

STEP 15

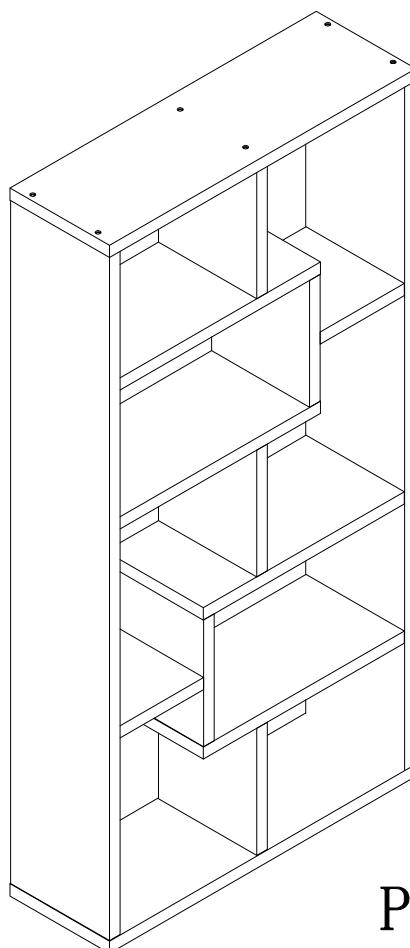

ANTI-TIPPING STRAP INSTRUCTION

HARDWARE (INCLUDED) :

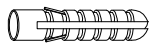

DRYWALL ANCHOR $\phi 8 \times 40$ X 1PC

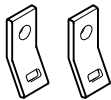

METAL BRACKETS $12 \times 12 \times 1$ X 2PCS



DRYWALL SCREW $\phi 5 \times 40$ X 1PC



STRAP $197 \times 5 \times 1$ X 1PC



FLATHEAD SCREW $\phi 4 \times 25$ X 1PC

TOOLS NEEDED (NOT INCLUDE

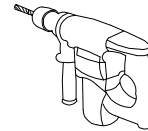

DRILL & DRILL BIT



LIGHT HAMMER

Note: Hardware included only compatible with standard drywalls.

STEP 1

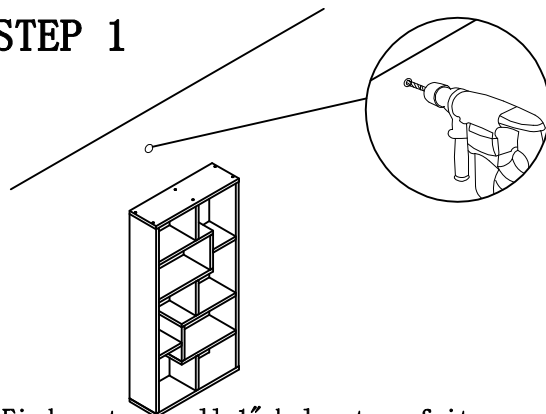

1. Find spot on wall 1" below top of item.
2. Using a drill bit slightly thinner than anchor, drill hole into drywall.

STEP 2

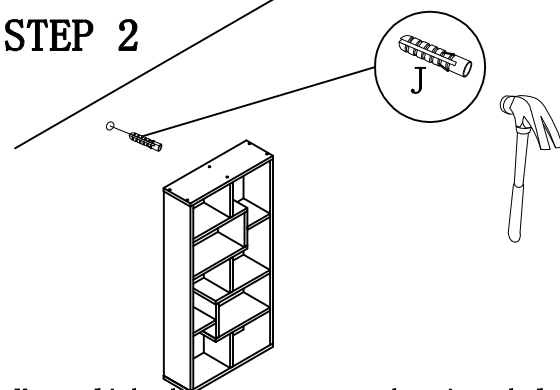

1. Use a light hammer to tap anchor into hole.
2. Anchor should fit snugly. If hole is too small, drill again to increase hole size. Do not force anchor into wall.

STEP 3

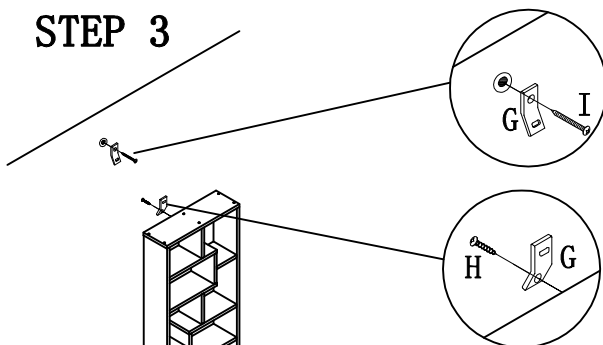

1. Insert drywall screw into metal bracket and into drywall anchor.
2. Insert flathead screw into second metal bracket and into back of item along top edge.

STEP 4

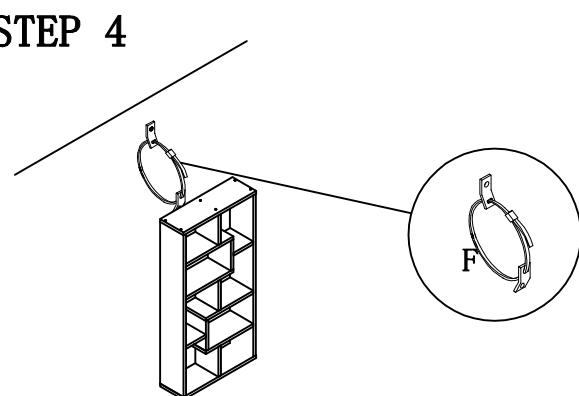

1. Insert strap thru bracket attached to wall, then thru bracket on item, and into head of strap.
 2. pull lightly til strap stops.
- Assembly is complete.