

ASSEMBLY INSTRUCTION

ITEM#: 171968

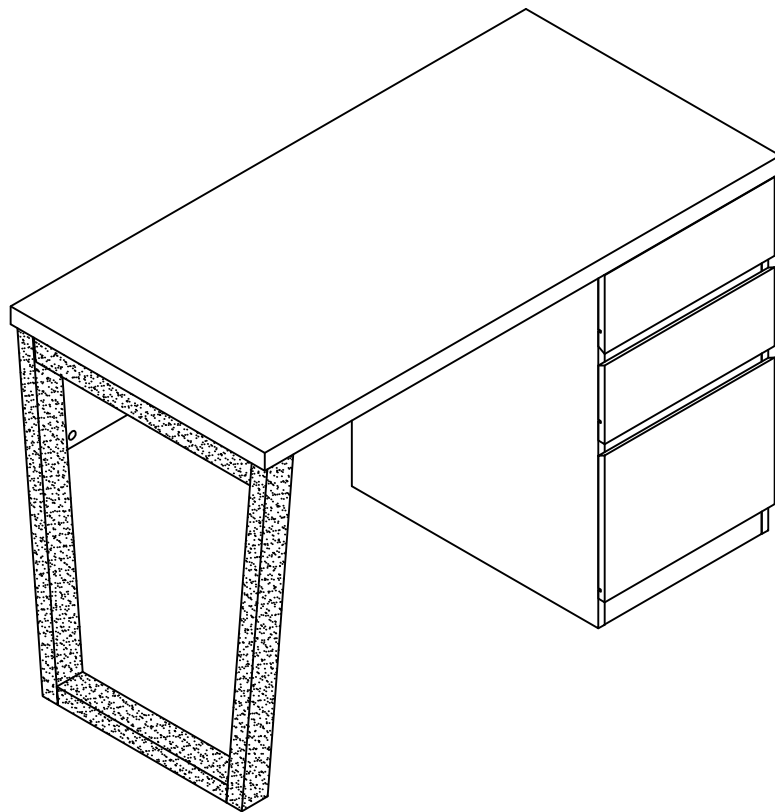

ASSEMBLY INSTRUCTION

PLEASE READ BEFORE ASSEMBLING!

Tip #1: Make sure you've taken all the pieces and hardware out of its packaging before discarding the box. Assembly on top of flattened box/blanket is recommended.

Tip #2: Using page 2 and/or page 3 of instruction manual make sure all pieces and hardware are accounted for.

Tip #3: Note position of all holes on each panel during assembly.

ITEM#: 171968

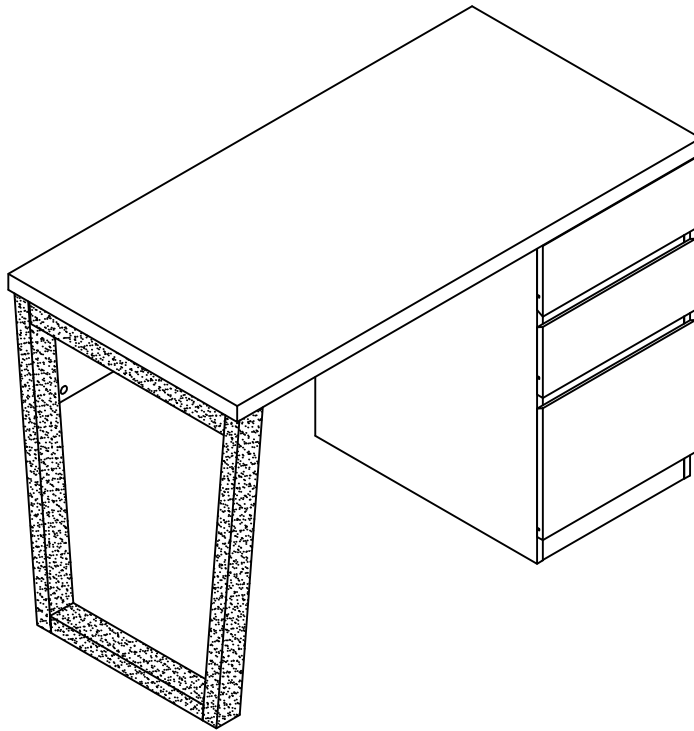

PARTS IDENTIFICATION



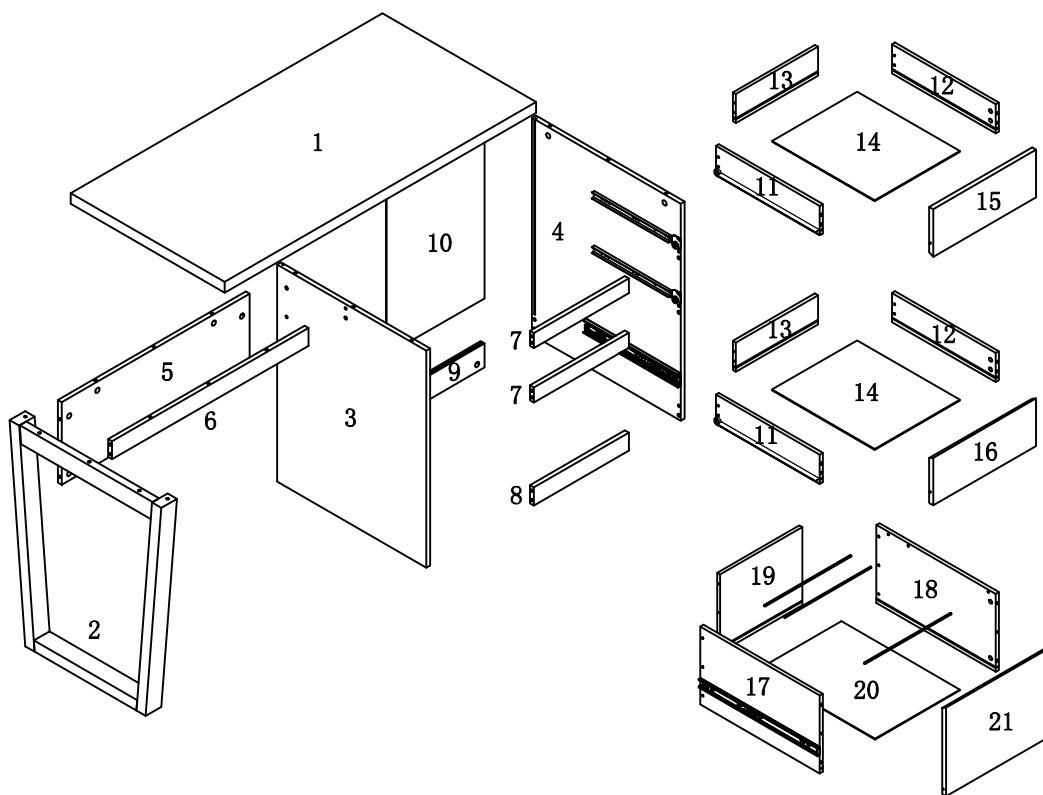





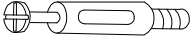

ITEM#: 171968

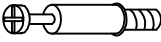

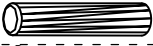
| | | | | | |
|-----|------|------|------|------|-----|
| (1) | 1pc | (8) | 1pc | (15) | 1pc |
| (2) | 1pc | (9) | 1pc | (16) | 1pc |
| (3) | 1pc | (10) | 1pc | (17) | 1pc |
| (4) | 1pc | (11) | 2pcs | (18) | 1pc |
| (5) | 1pc | (12) | 2pcs | (19) | 1pc |
| (6) | 1pc | (13) | 2pcs | (20) | 1pc |
| (7) | 2pcs | (14) | 2pcs | (21) | 1pc |

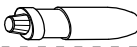

HARDWARE IDENTIFICATION

ITEM#: 171968

| | | | |
|---|--|--|-------|
| A |  | L29 | 26pcs |
| B |  | ø15 | 26pcs |
| C |  | L20 | 12pcs |
| D |  | ø12 | 12pcs |
| E |  | ø8x25 | 17pcs |
| F |  | ø6x30 | 2pcs |
| G |  | ø4x30 | 14pcs |
| H |  | ø5x323 | 3pcs |
| I |  | ø5x9 | 3pcs |
| J |  | ø20 (BLK3) | 4pcs |
| K |  | ø20 (DGY) | 10pcs |
| L |  | ø16 | 6pcs |
| M |  | Glue: For securing please apply to wood dowel first before inserting into panel | 1pc |

ASSEMBLY INSTRUCTION

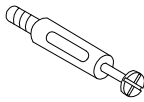
ITEM#: 171968

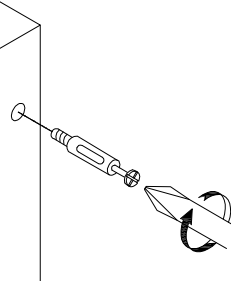
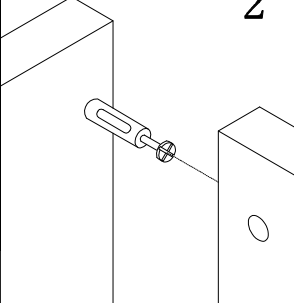
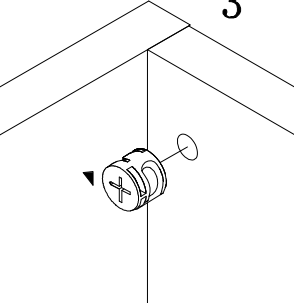
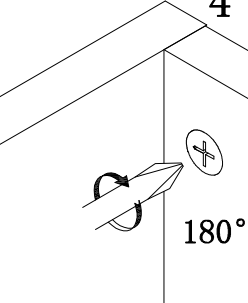
| HOW TO | 1 | 2 | 3 | 4 |
|---|---|---|--|---|
|  <p>Cam Bolt</p>  <p>Cam Lock</p> |  |  |  |  <p>180°</p> |
| | <p>1. Screw Cam Bolt into panel.</p> | <p>2. Insert Cam Bolt into bolt hole of joining panel.</p> | <p>3. Insert Cam Lock. arrow facing bolt.</p> | <p>4. Gently turn Cam Lock clockwise to lock position.</p> |

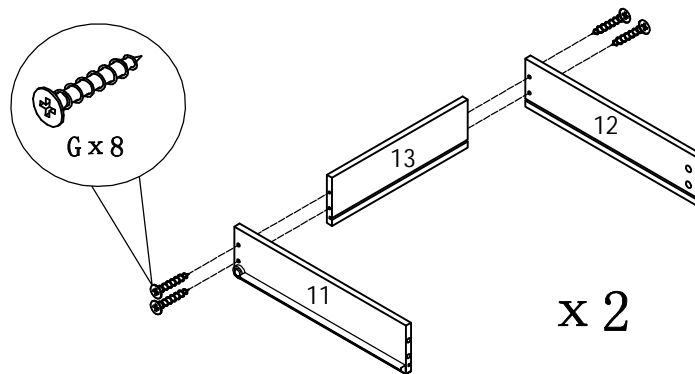

STEP 1

STEP 2

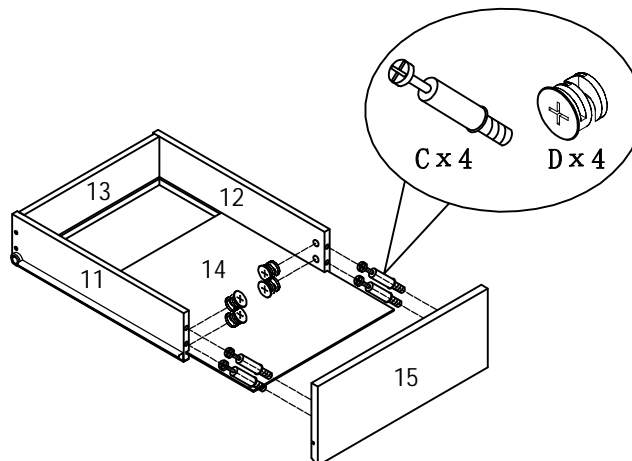

ASSEMBLY INSTRUCTION

ITEM#: 171968

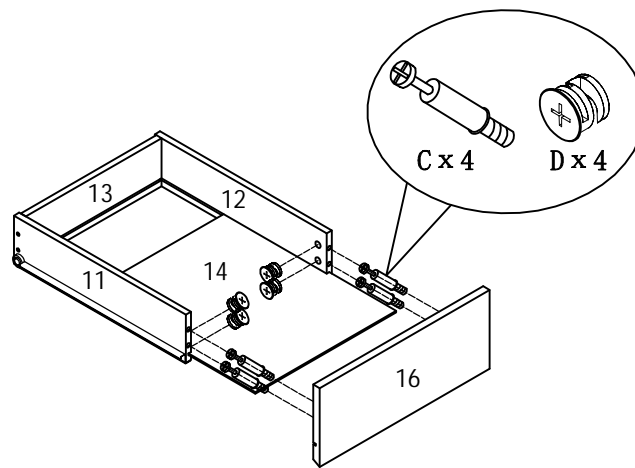

STEP3

STEP4

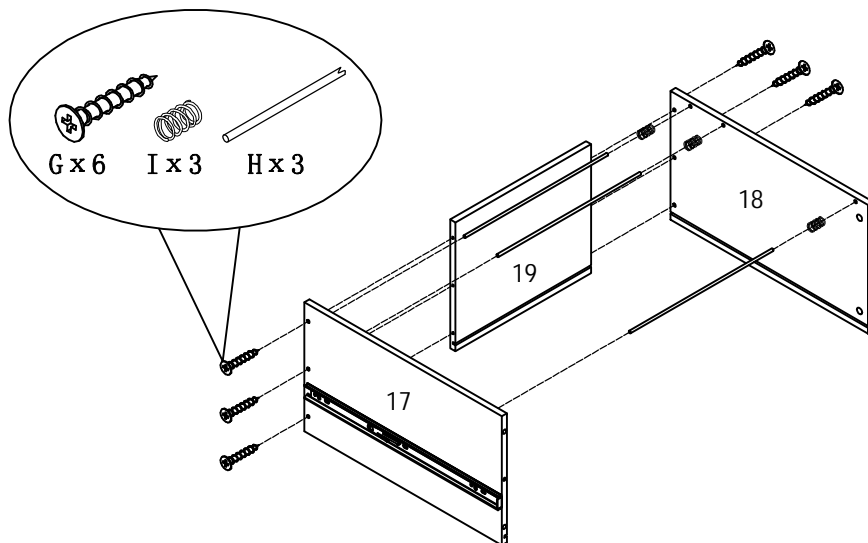

ASSEMBLY INSTRUCTION

ITEM#: 171968

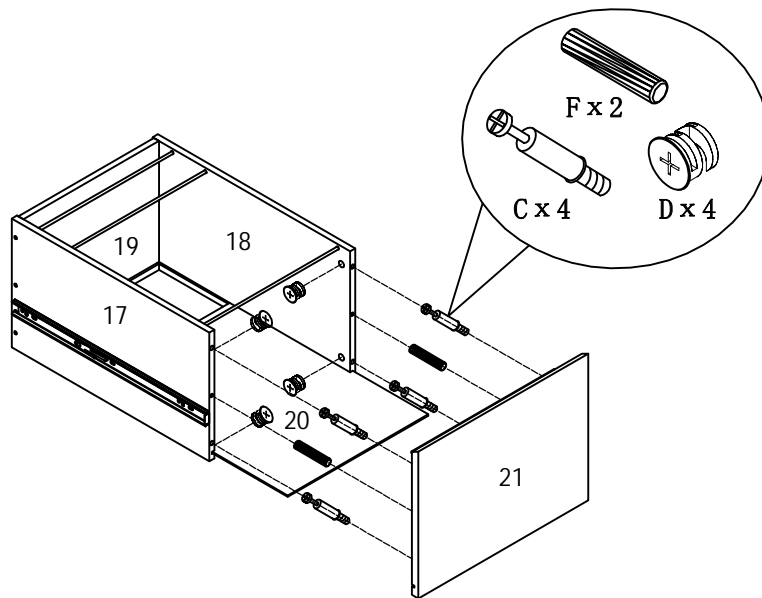

STEP5

STEP6

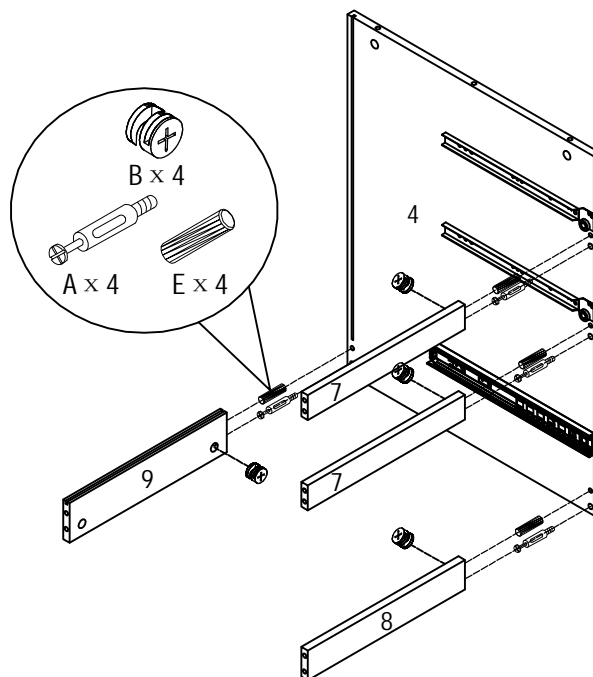

ASSEMBLY INSTRUCTION

ITEM#: 171968

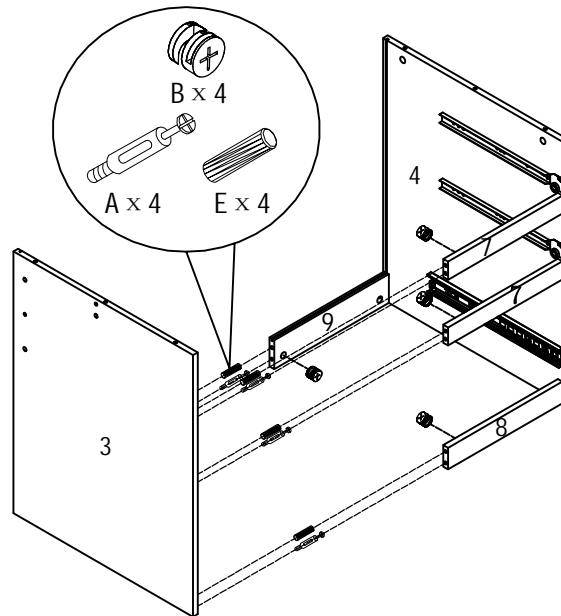

STEP7

STEP8

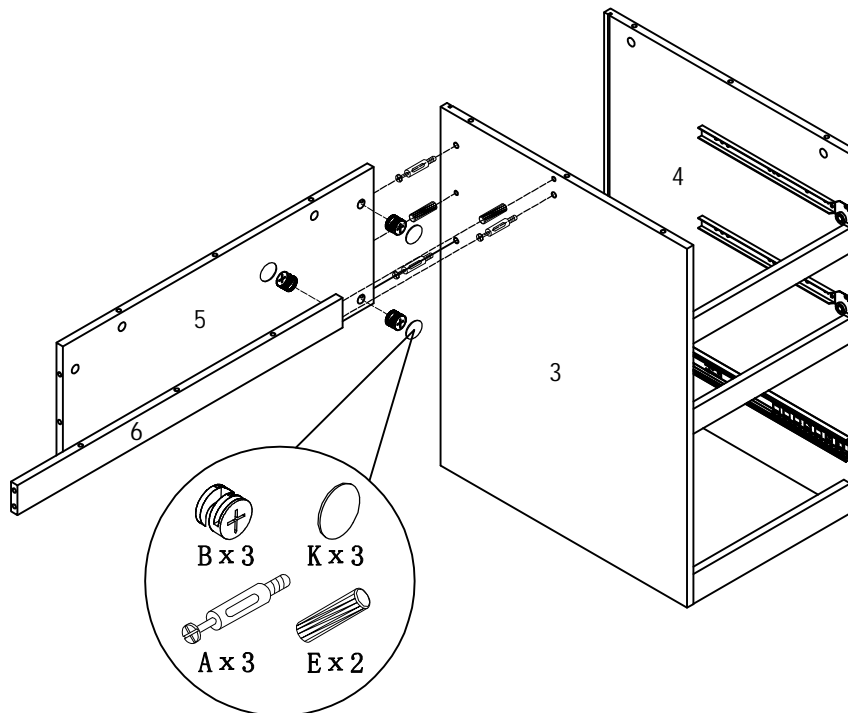

ASSEMBLY INSTRUCTION

ITEM#: 171968

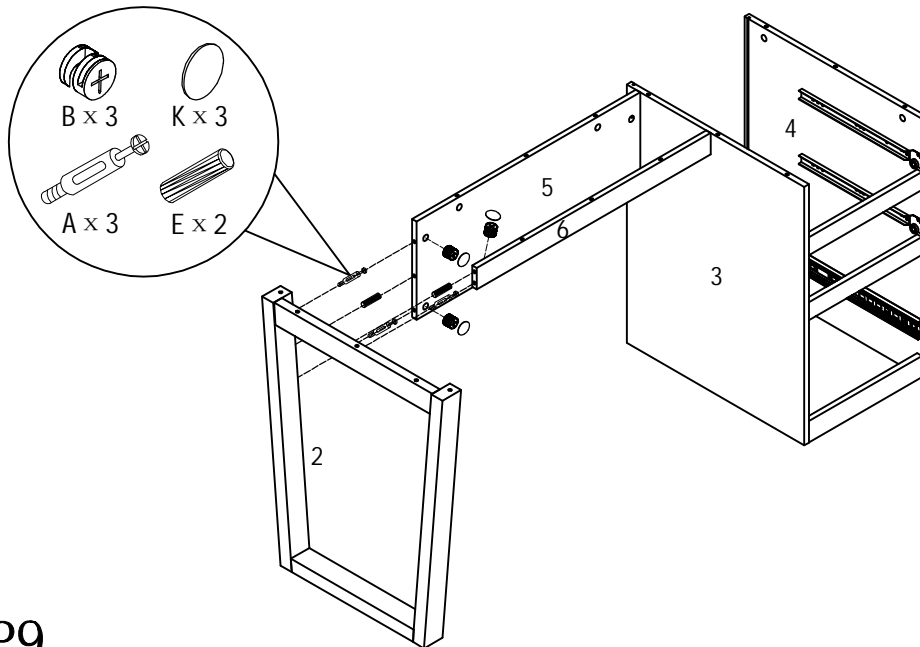

STEP9

STEP10

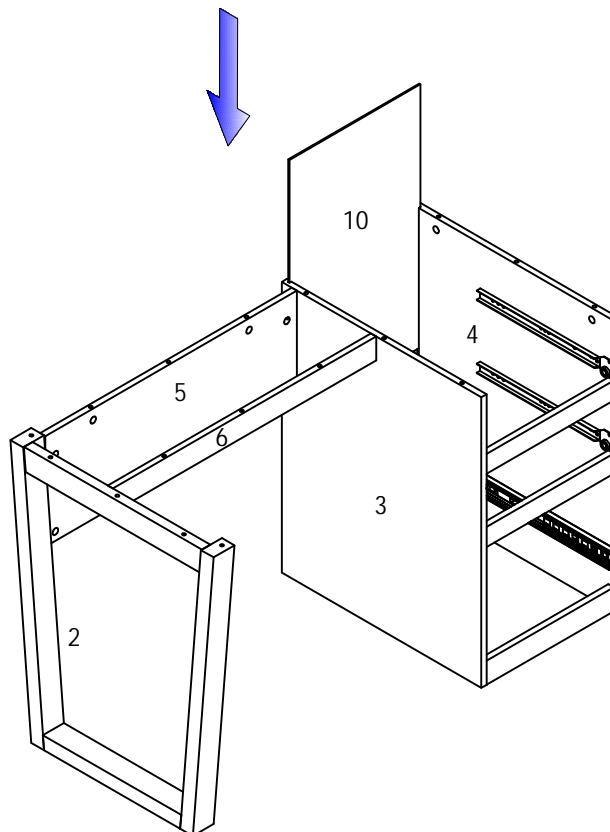

ASSEMBLY INSTRUCTION

ITEM#: 171968

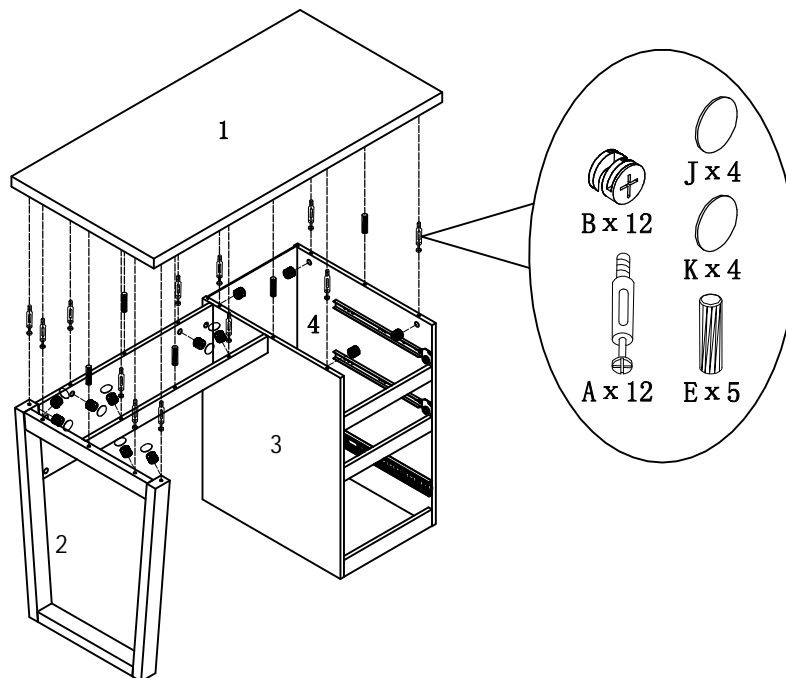

STEP11

STEP12

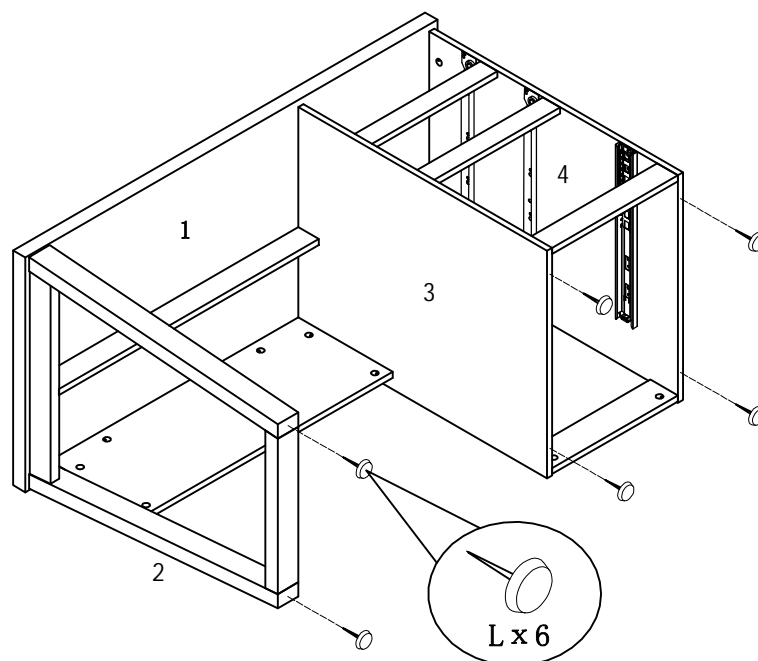

ASSEMBLY INSTRUCTION

ITEM#: 171968

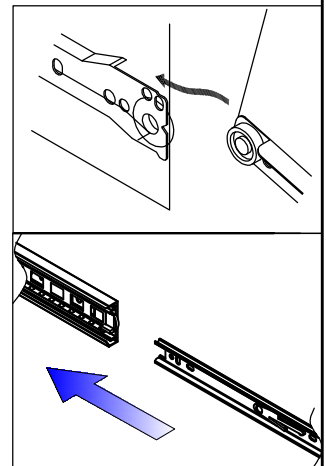
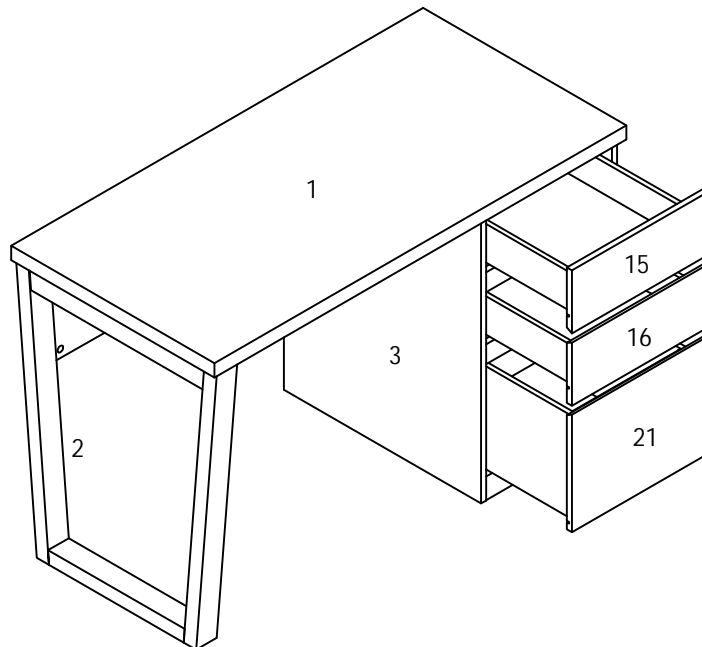

STEP13

STEP14

