

ASSEMBLY INSTRUCTION

PATIO CONVERSATION SET

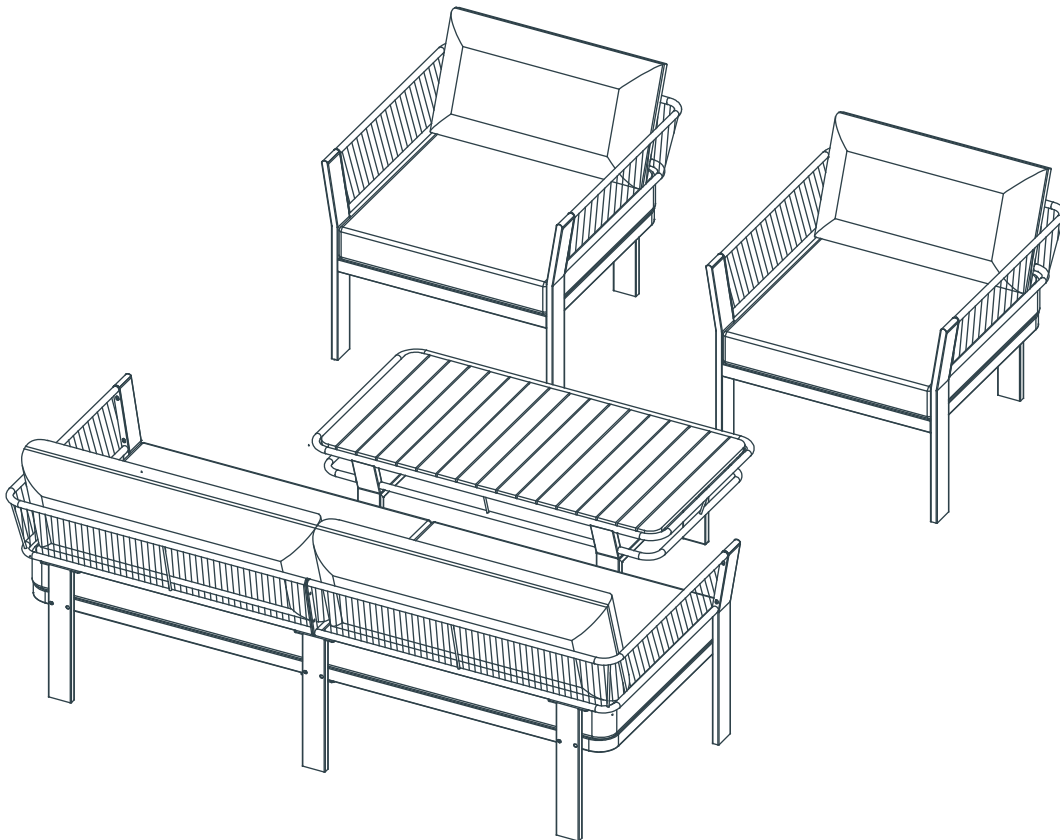

WF318743; WF318744; WF318745

Please read all instructions carefully:

1. Have 2 adults on hand for assembly.
2. 50% Tighten before fixing all screws, Allen wrench is recommended instead of an electric drill.
3. Place the item on a flat ground to adjust and make sure it remains stable.
4. Tighten up all screws with tools gradually.
5. If the screws are not aligned with holes during assembly, please loosen all the other screws to 50% and continue the assembly process.
6. If the item is not stable, please loosen all the screws, adjust it on a flat ground and tighten up all screws again.
7. Note : If one or some screws are fully tightened during assembly, chances are the others will not be aligned with holes. In addition, all the holes are designed to be relatively larger to provide more space for the adjustment of the screws.

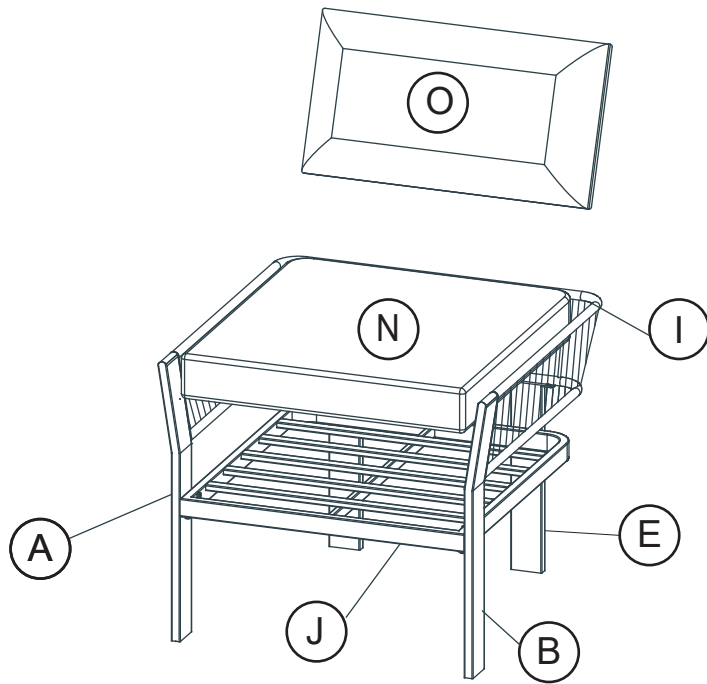

x2

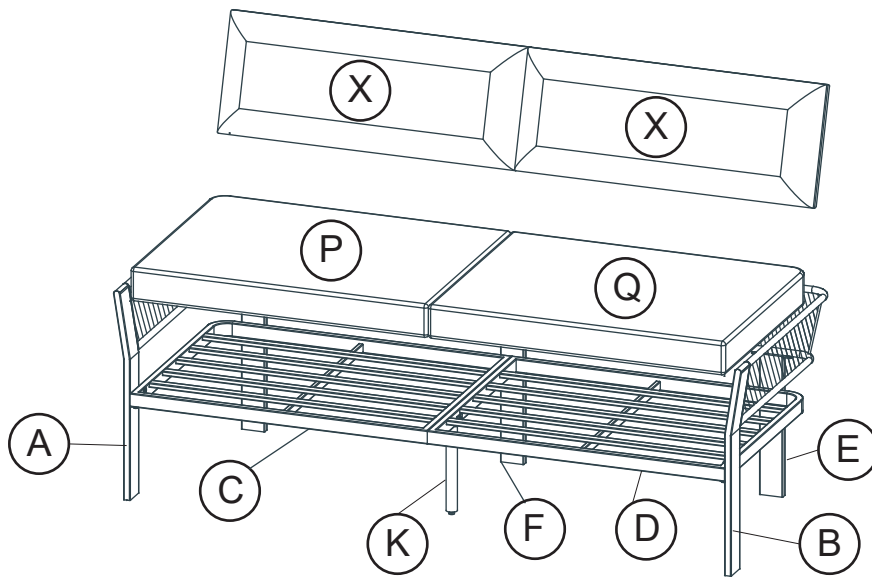



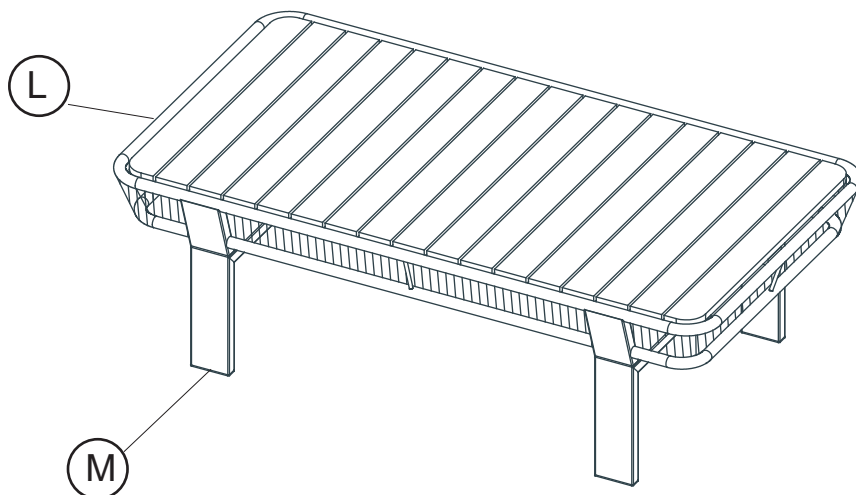



x1



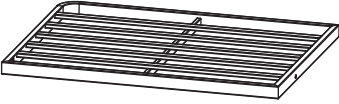
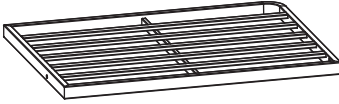

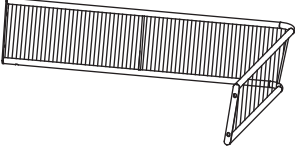
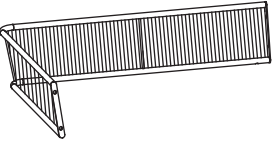

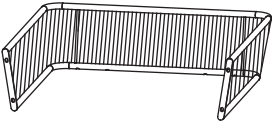
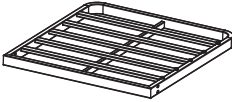
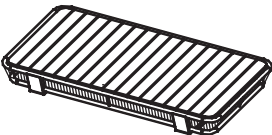
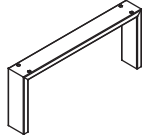
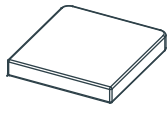
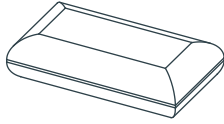
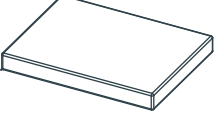
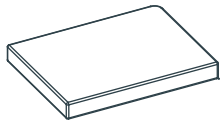
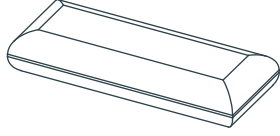



x1

Part List :



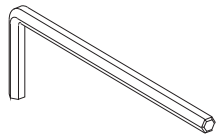

A  Right Front Chair Leg (3pcs)	B  Left Front Chair Leg (3pcs)	C  Right Seat Bench Frame (1pc)	D  Left Seat Bench Frame (1pc)
E  Back Chair Leg (6pcs)	F  Back Middle Chair Leg (1pc)	G  Left Armless (1pc)	H  Right Armless (1pc)
K  Middle Chair Leg (1pc)	I  Armless (2pcs)	J  Seat Chair Frame (2pcs)	L  Top Table (1pc)
M  Table Leg (2pcs)	N  Seat Chair Cushion (2pcs)	O  Back Chair Cushion (2 pcs)	P  Right Seat Bench Cushion (1pc)
Q  Left Seat Bench Cushion (1pc)	X  Back Bench Cushion (2pcs)		

Hardware list:

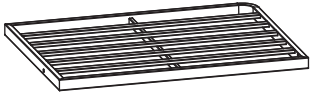
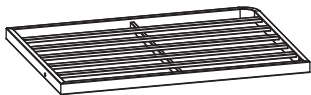

1  Extra (2 pcs) Bolt M6x20 (16 pcs)	2  Extra (2 pcs) Bolt M6x35 (26 pcs)	3  Extra (1 pcs) Bolt M6x55 (1 pcs)	4  Extra (1 pcs) Nult M6 (3 pcs)
5  Key M6 - 10mm (1 pcs)	6  Extra (3 pcs) Flat Washer M6 (71 pcs)	7  Allen Key (2 pcs)	8  Extra (2 pcs) Bolt M6x15 (28 pcs)

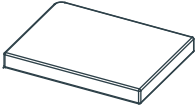
CARTON CONTENT:

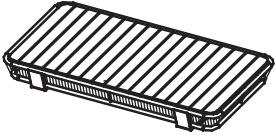
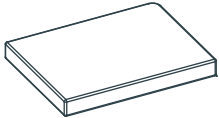
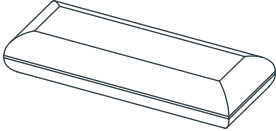
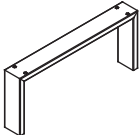

WF318743

<p>C</p>  <p>Left Seat Bench Frame (1pc)</p>	<p>D</p>  <p>Left Seat Bench Frame (1pc)</p>	<p>J</p>  <p>Seat Chair Frame (2pcs)</p>	<p>P</p>  <p>Right Seat Bench Cushion (1pc)</p>
<p>F</p>  <p>Back Middle Chair Leg (1pc)</p>	<p>K</p>  <p>Middle Chair Leg (1pc)</p>		

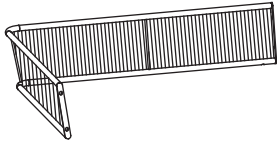
WF318744

<p>L</p>  <p>Top Table (1pc)</p>	<p>Q</p>  <p>Left Seat Bench Cushion (1pc)</p>	<p>X</p>  <p>Back Bench Cushion (2pcs)</p>	<p>M</p>  <p>Table Leg (2pcs)</p>
<p>E</p>  <p>Back Chair Leg (6pcs)</p>	<p>H</p>  <p>Right Armless (1pc)</p>		

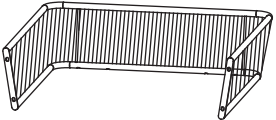
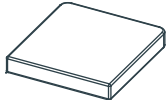
WF318745

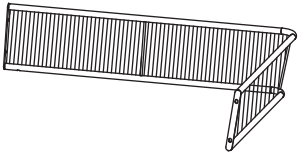
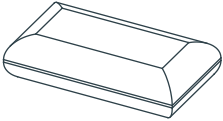
<p>I</p>  <p>Armless (2pcs)</p>	<p>N</p>  <p>Seat Chair Cushion (2pcs)</p>	<p>A</p>  <p>Right Front Chair Leg (3pcs)</p>	<p>B</p>  <p>Left Front Chair Leg (3pcs)</p>
<p>G</p>  <p>Left Armless (1pc)</p>	<p>O</p>  <p>Back Chair Cushion (2 pcs)</p>		

STEP 1

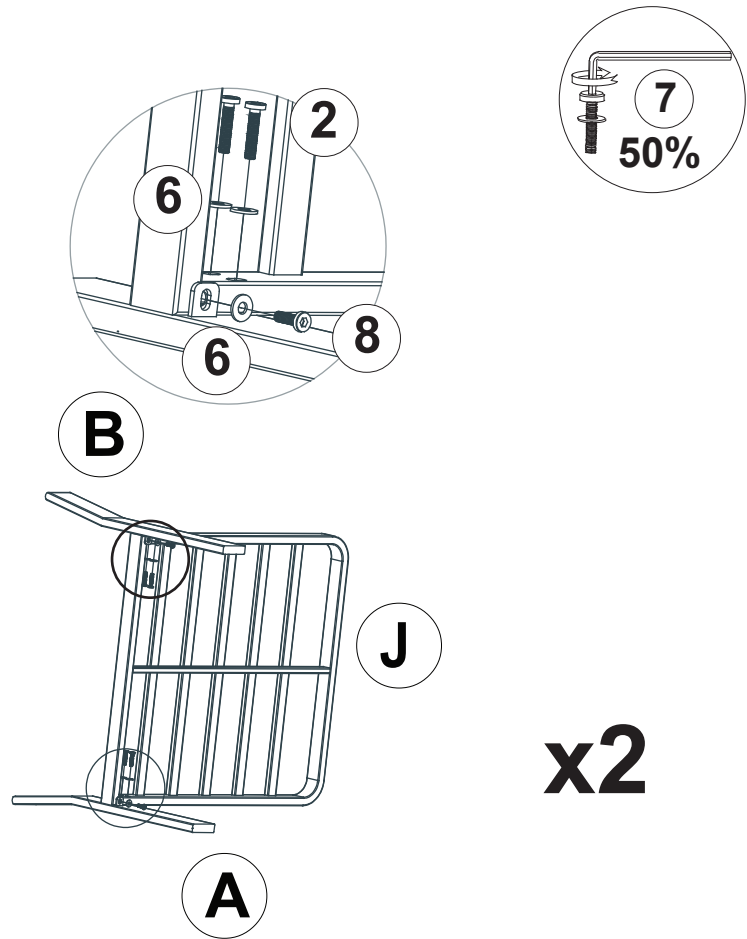
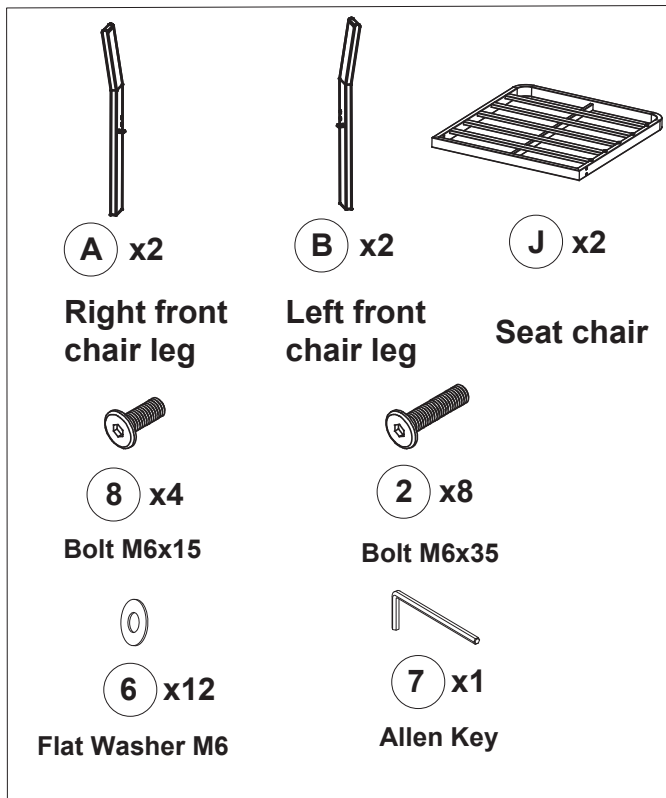

Connect Right Front Chair Leg (A), Left Front Chair Leg (B) & Seat Chair (J), tighten Bolt (8), (2) & flat washer (6) with Allen key

STEP 2

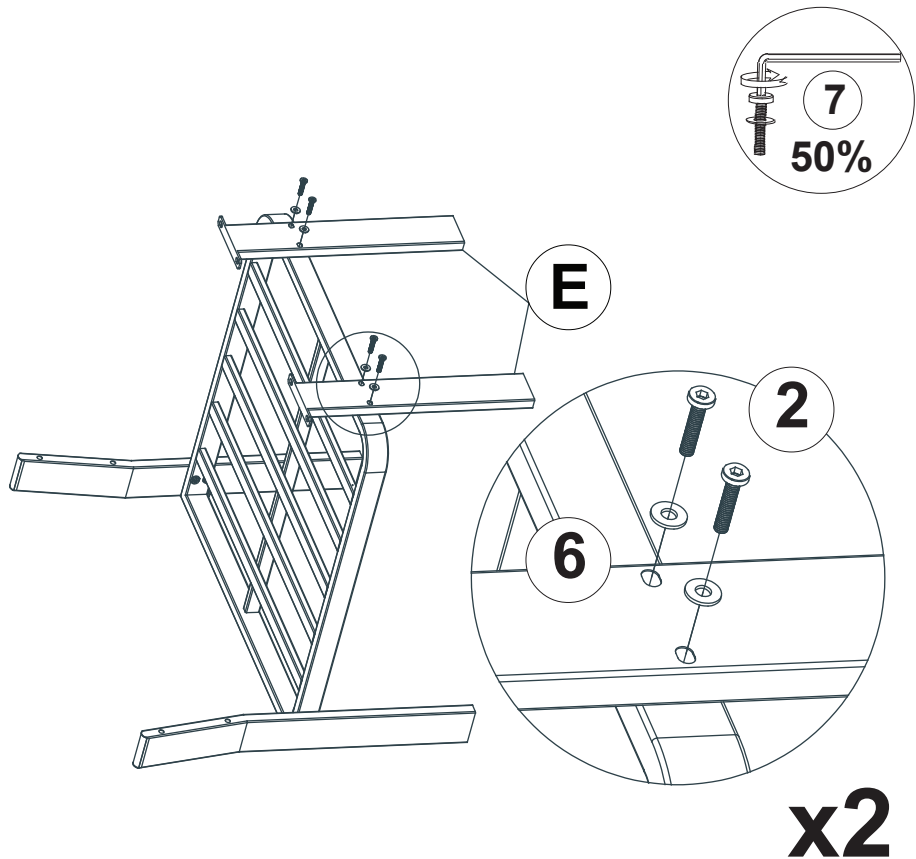
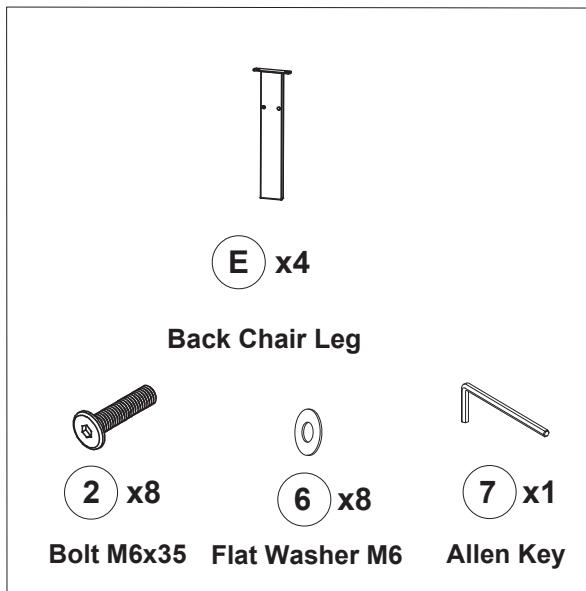

Connect Back Chair Leg (E) & Seat Chair (J), tighten Bolt (2) & flat washer (6) with Allen key (7)

STEP 3

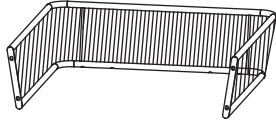
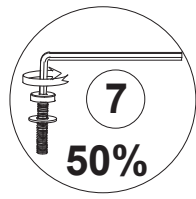

Armless

1 x2



8 x8

6 x8

7 x1

Bolt M6x15

Flat Washer M6

Allen Key

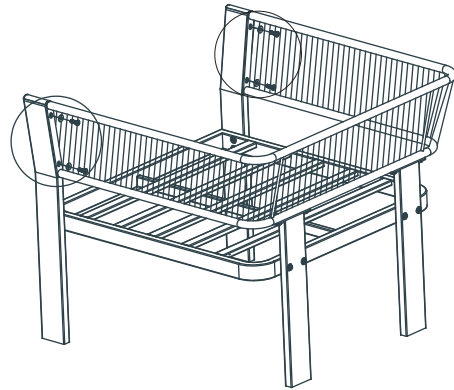
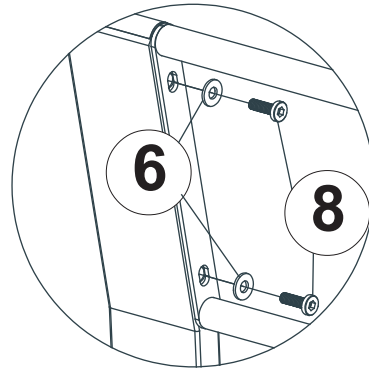

1

x2

Connect Armless (1), Right Front Chair Leg (A), Left Front Chair Leg (B), tightening Bolt (8) & Flat Washer (6) & Allen Key (7).

STEP 4

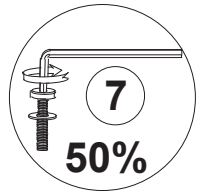

1 x8

Bolt M6x20



6 x8

7 x1

Flat Washer M6

Allen Key

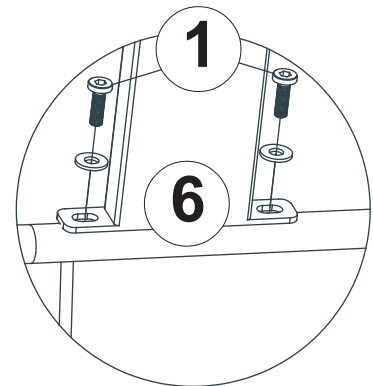
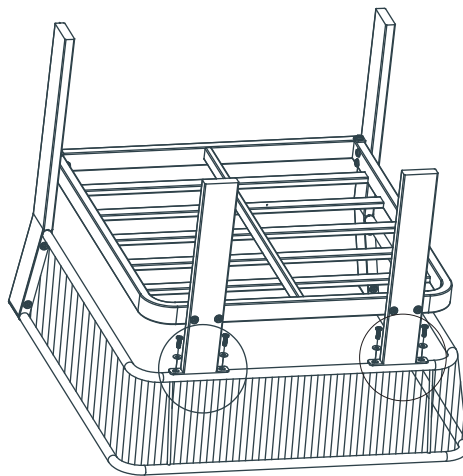

x2

Connect the part from step 3 Back Chair Leg (E), tighten Bolt (1) & Flat Washer (6) with Allen Key (7).

STEP 5

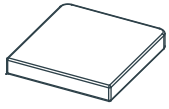

N x2

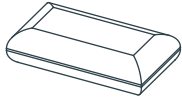

O x2

Seat Chair Cushion Back Chair Cushion

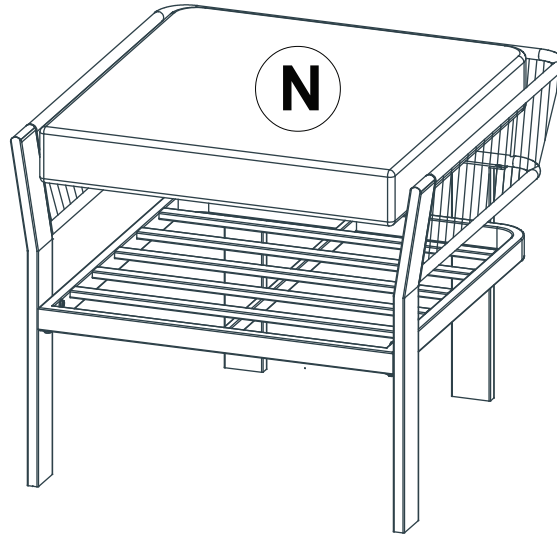
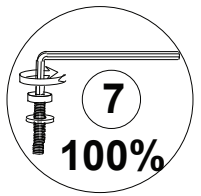
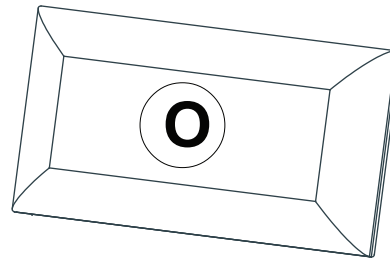

x2

**Put Chair upright, firmly tighten Bolts with Allen Key (7)
Set up the Cushions (N)+(O) to finish Chair.**

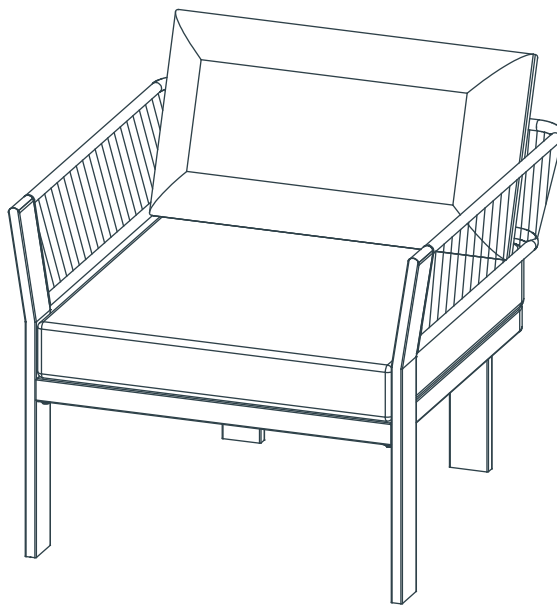

x2

Finish chair

STEP 6

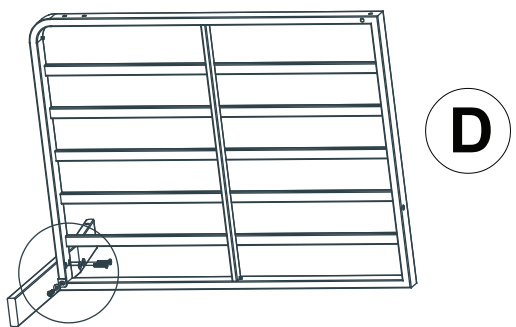
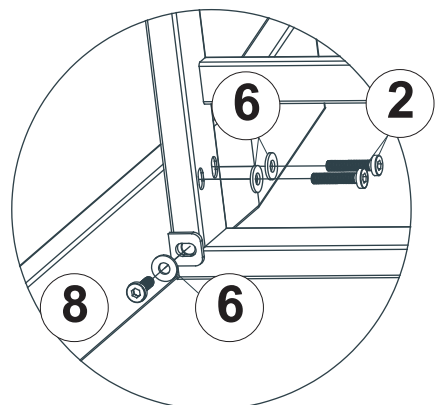
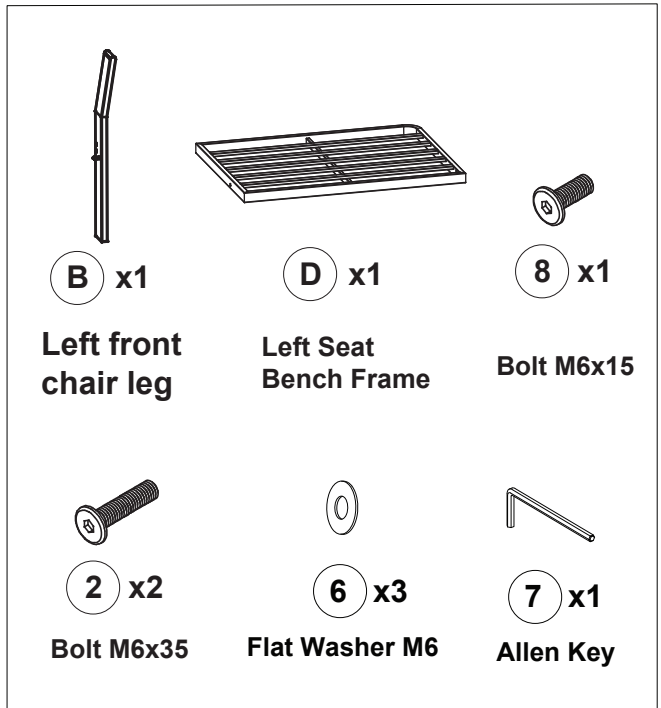
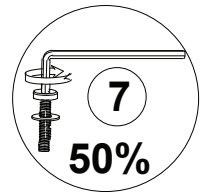

Connect Left front chair leg (B) & Left Seat Bench Frame(D), tighten Bolt (8),(2) & flat washer (6) with Allen key

STEP 7

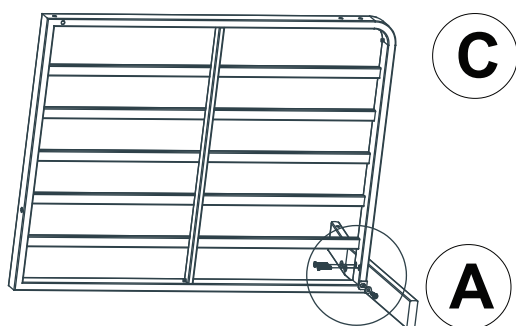
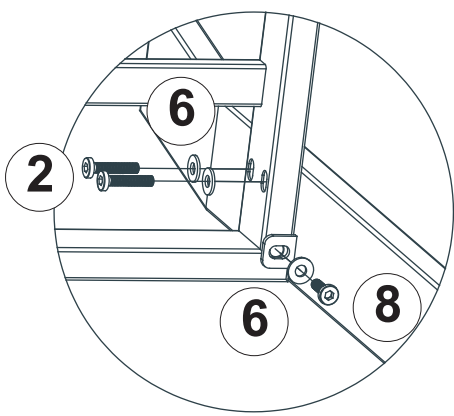
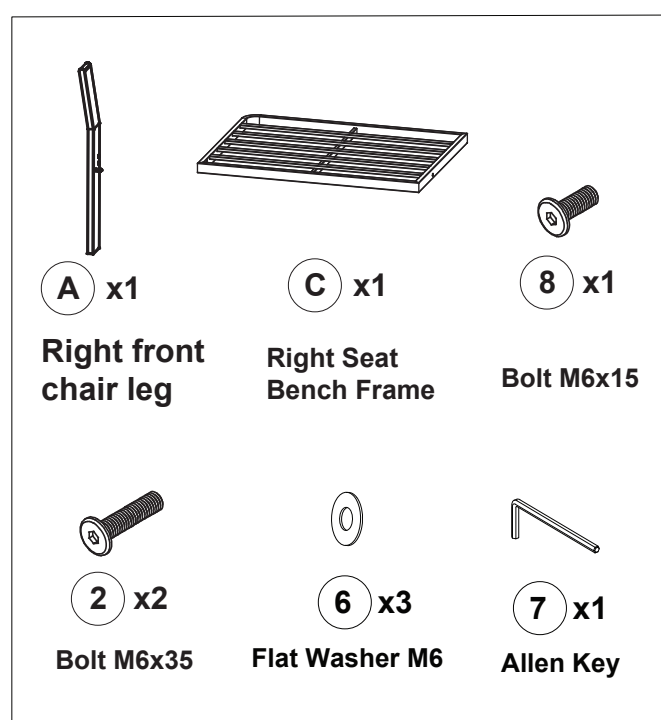
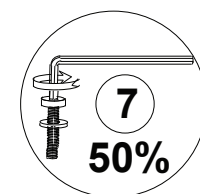

Connect Right front chair leg (A) & Right Seat Bench Frame(C), tighten Bolt (8),(2) & flat washer (6) with Allen key

STEP 8

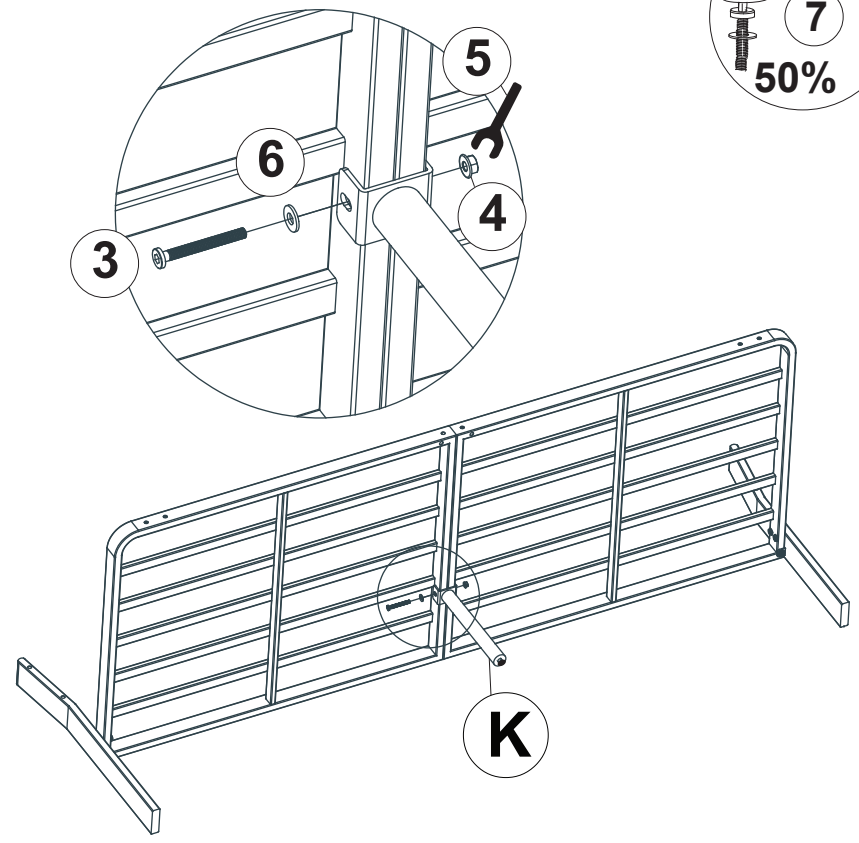
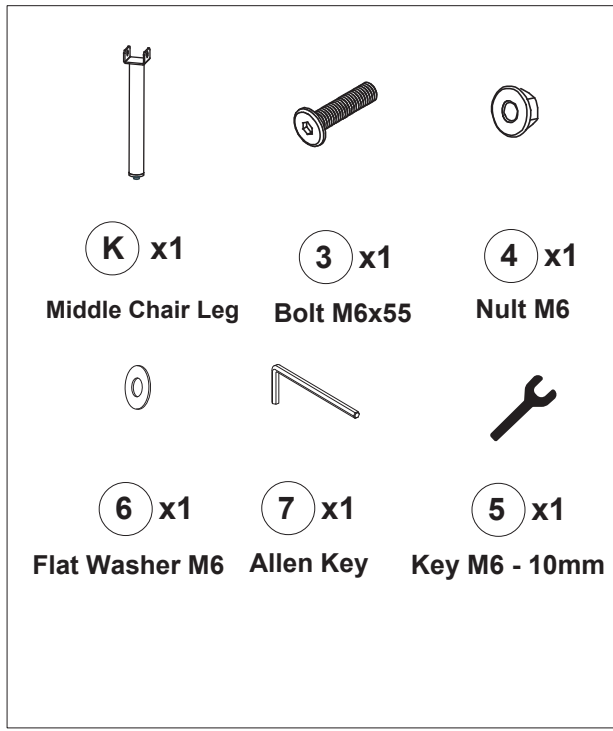
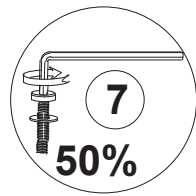

Connect Middle Chair Leg (K), Left Seat Bench Frame(D) & Right Seat Bench tighten Bolt (3), Nut (4) & flat washer (6) with Allen key & Key M6-10mm (5)

STEP 9

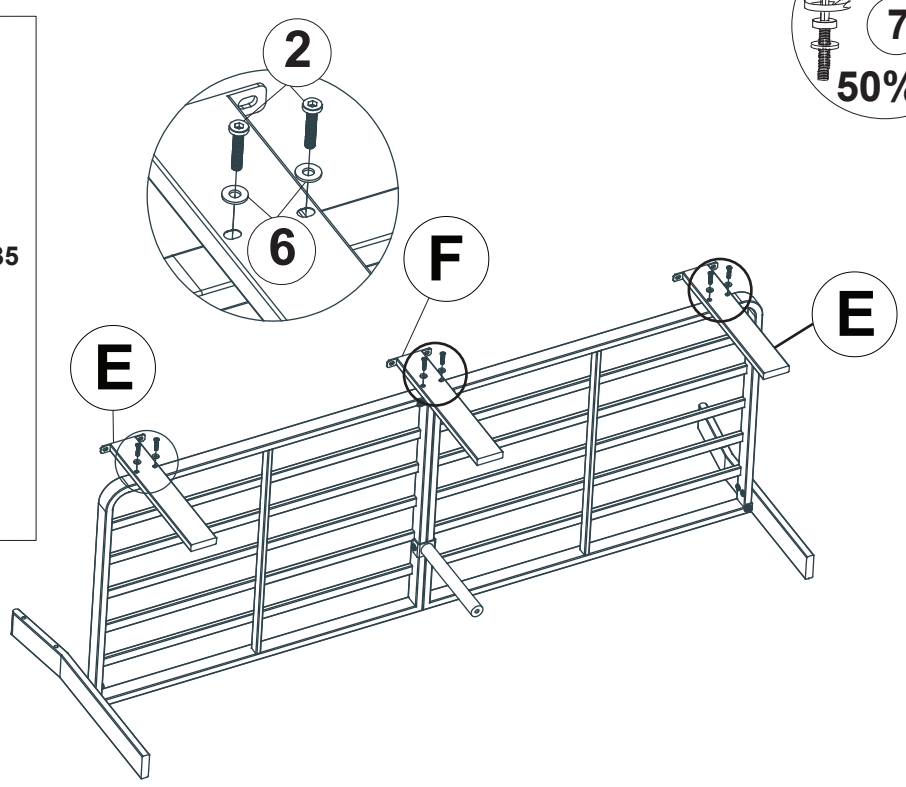
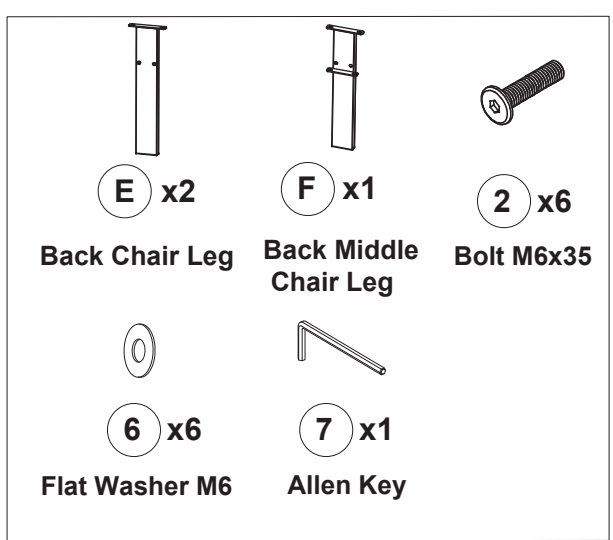
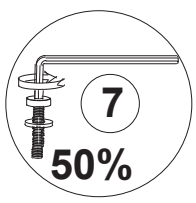

Connect Back Chair Leg (E), Back Middle Chair Leg (F), Left Seat Bench Frame (D) Right Seat Bench (C), tighten Bolt (2), & flat washer (6) with Allen key (7)

STEP 10

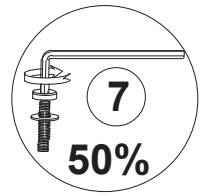

8 x2

Bolt M6x15



6 x2

Flat Washer M6



7 x1

Allen Key

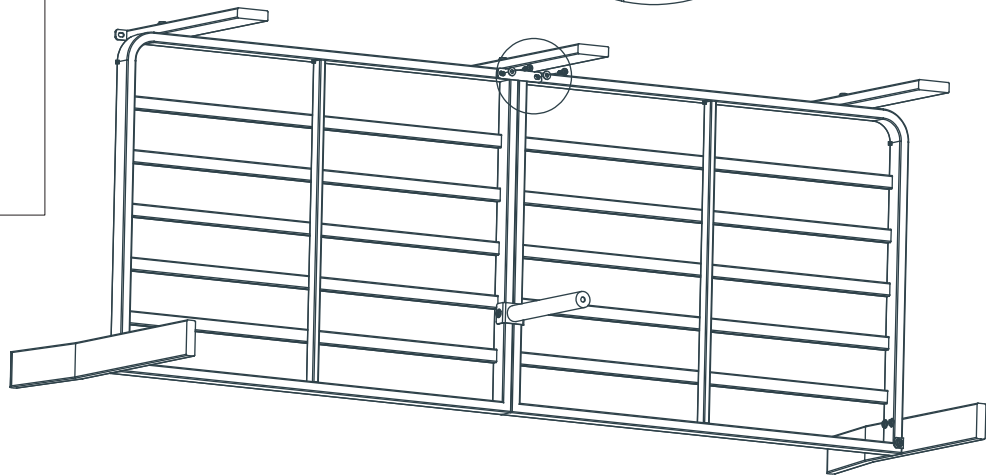
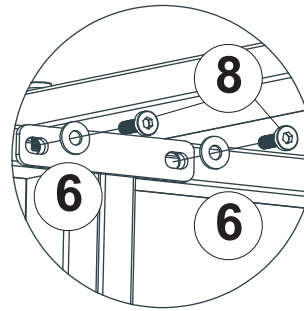

Connect The part from Step 8 & Back Middle Chair Leg (E), tighten Bolt (8) & Flat Washer (6) with Allen Key (7).

STEP 11

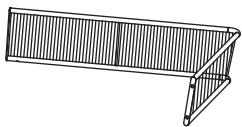
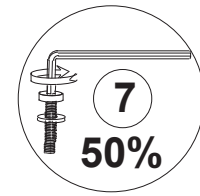

G x1

Left Armless

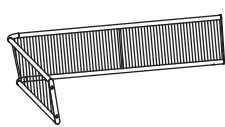

H x1

Right Armless



8 x4

Bolt M6x15



6 x4

Flat Washer M6



7 x1

Allen Key

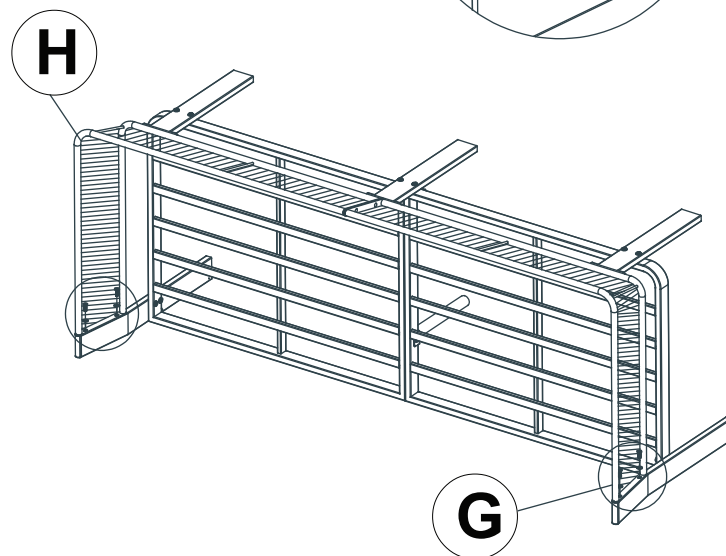
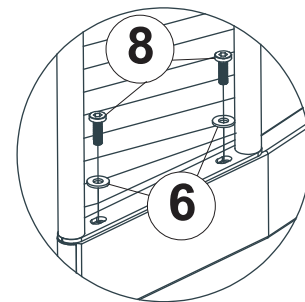

Connect Left Armless(G), Right Armless (H), Right Front Chair Leg (A), Left Front Chair Leg (B), tighten Bolt (8), & flat washer (6) with Allen key (7)

STEP 12

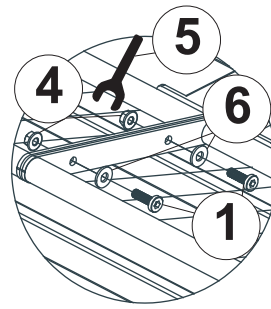
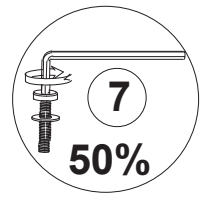

1 x2

4 x2

5 x1

Bolt M6x20 Nult M6 Key M6 - 10mm



6 x2

7 x1

Flat Washer M6 Allen Key

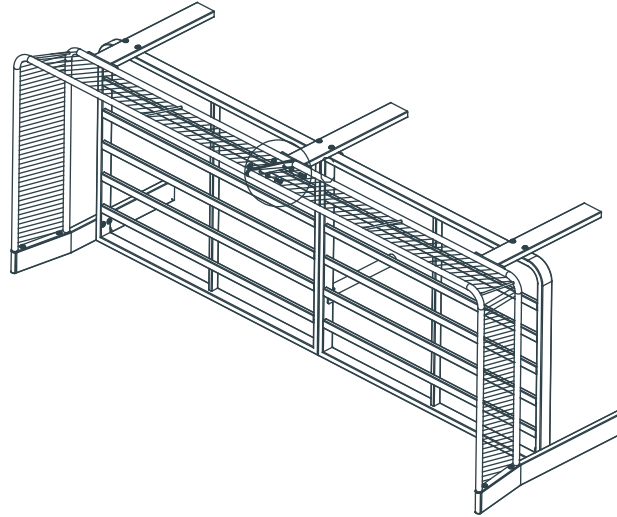

Connect The part from Step 10 Left Armless (H), Right Armless(K), tighten Bolt (1) ,Nult (4) & Flat Washe (6) with Allen Key (7) & Key M6-10mm

STEP 13

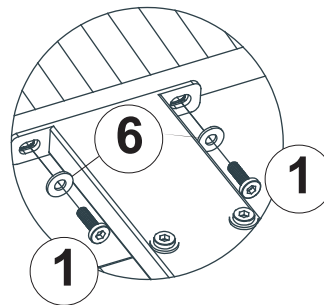
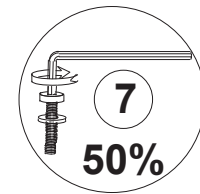

1 x6

Bolt M6x20



6 x6

7 x1

Flat Washer M6 Allen Key

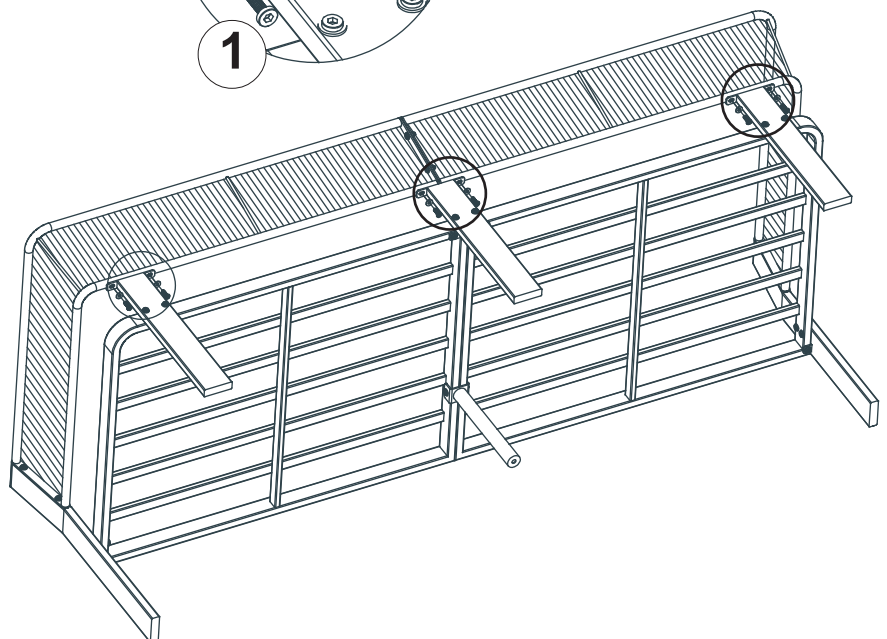

Connect the part from step 11 Back Chair Leg (F), Back Middle Chair Leg tighten Bolt (1) & Flat Washer (6) with Allen Key (7).

STEP 14

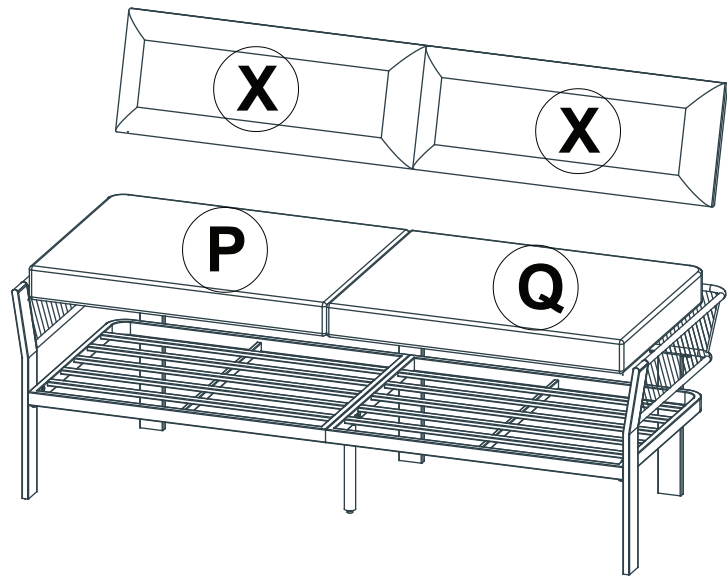
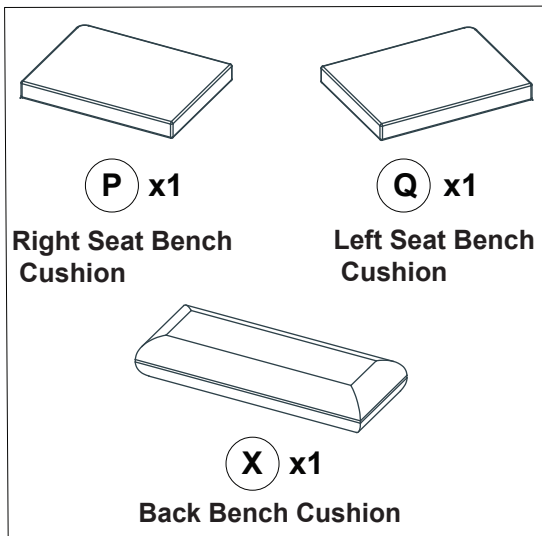
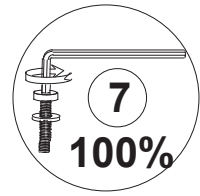

**Put Chair upright, firmly tighten Bolts with Allen Key (7)
Set up the Cushions (P)+(Q)+(X) to finish Chair.**

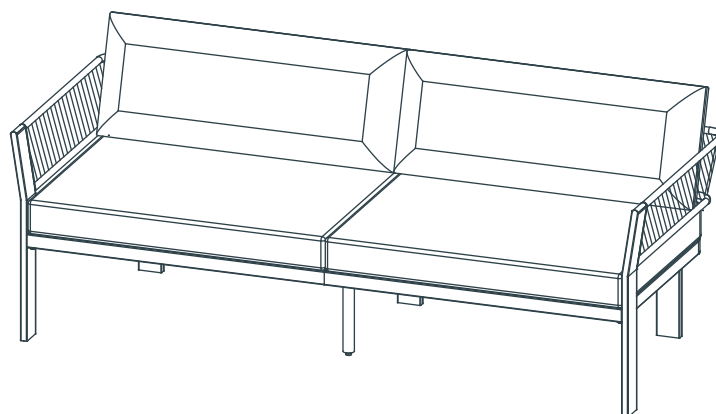

Finish Loveseat

STEP 15

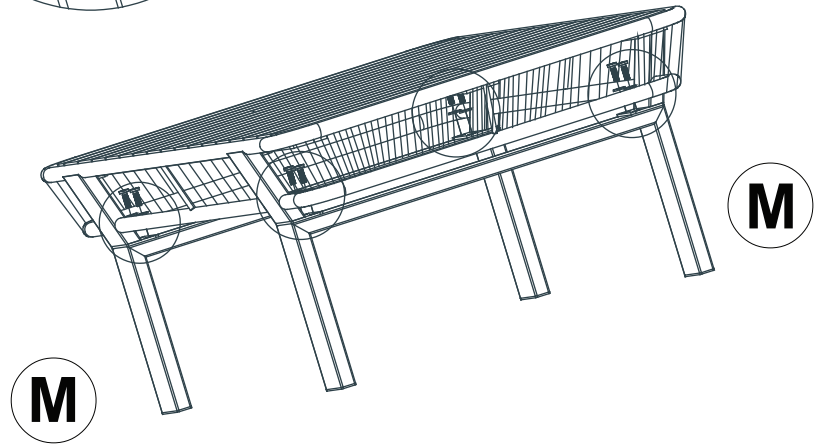
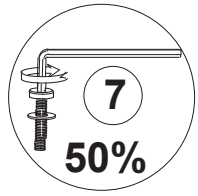
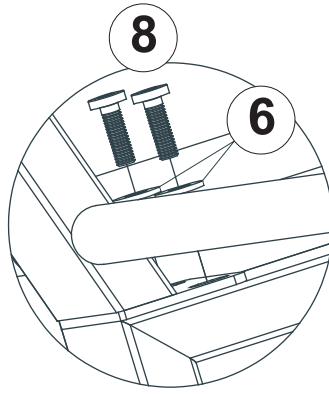
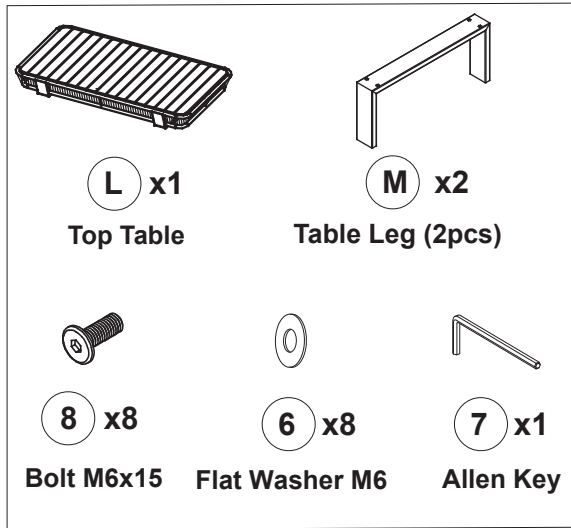

Connect Top Table (L), Table Leg (M), tighten Bolt (8), & flat washer (6) with Allen key (7)

STEP 16

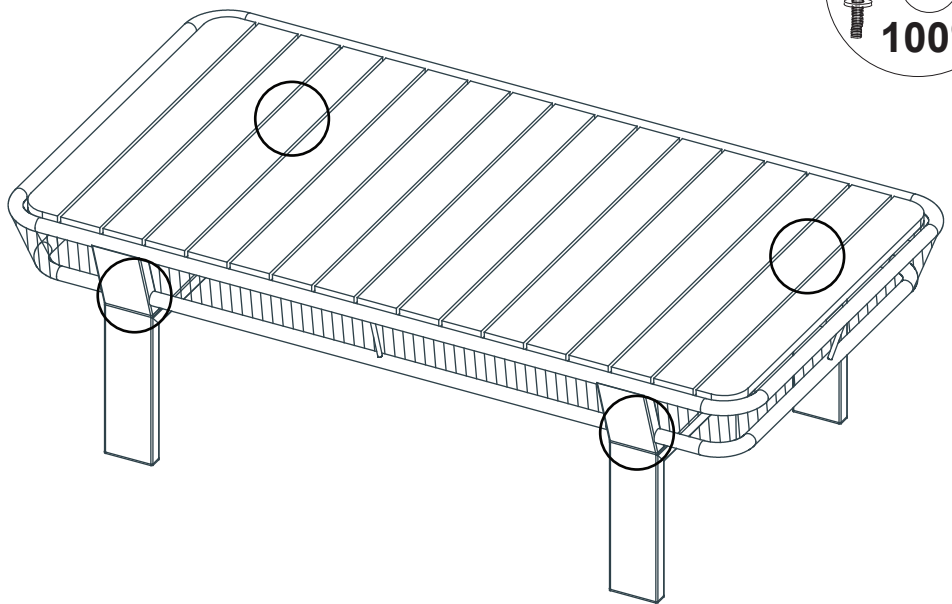
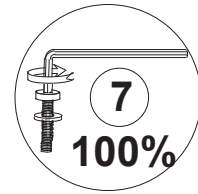
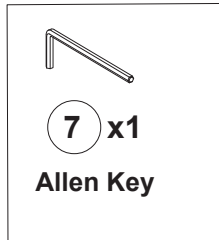

Put Chair upright, firmly tighten Bolts with Allen Key (7)

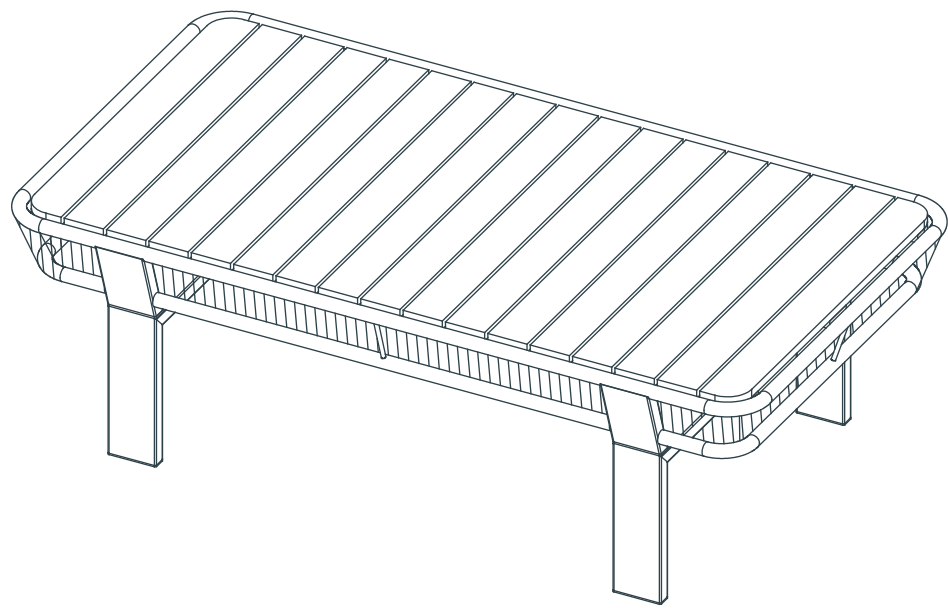

Finish Table

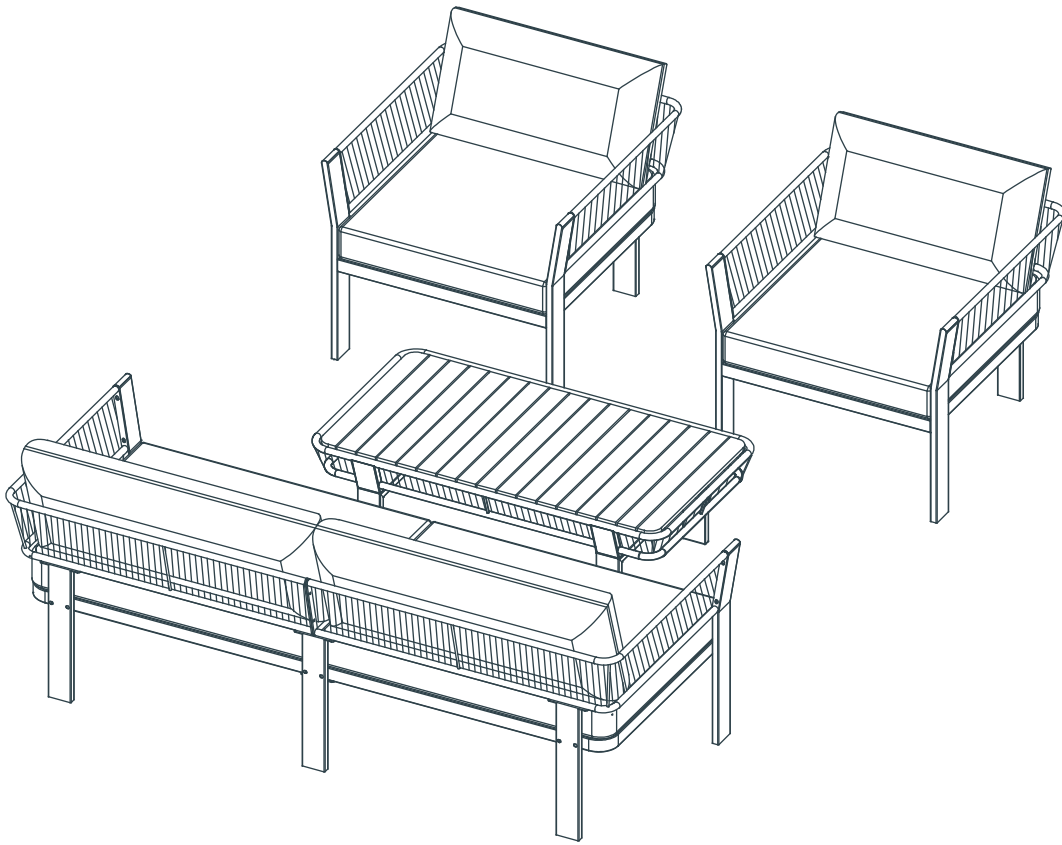

OPTION 1

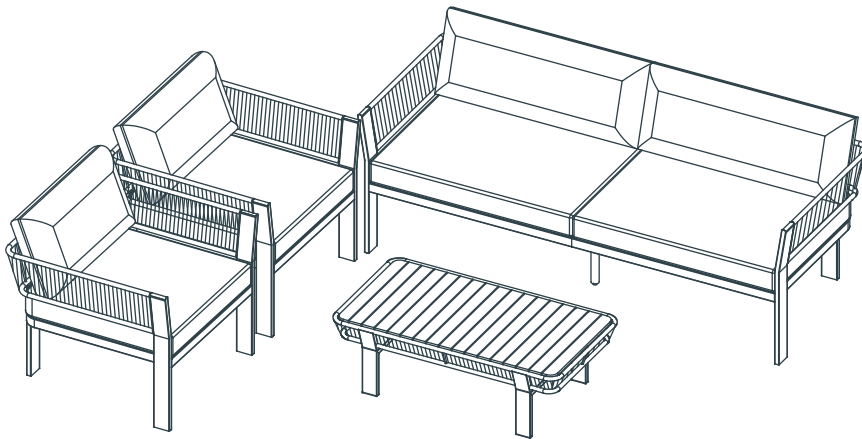

OPTION 2

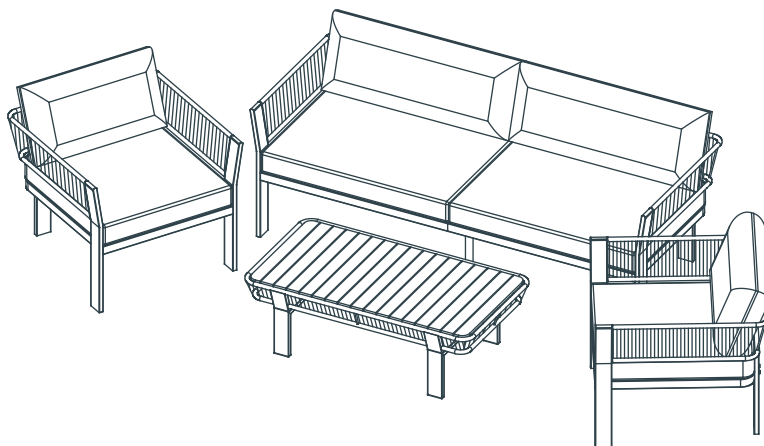

OPTION 3

Finish Patio Conversation Set