

ASSEMBLY INSTRUCTIONS

Item No : WF318109

Description : SIDEBOARD

Thank you for purchasing this quality product. Be sure to check all packing material carefully for small part that may have come loose inside carton during shipment.

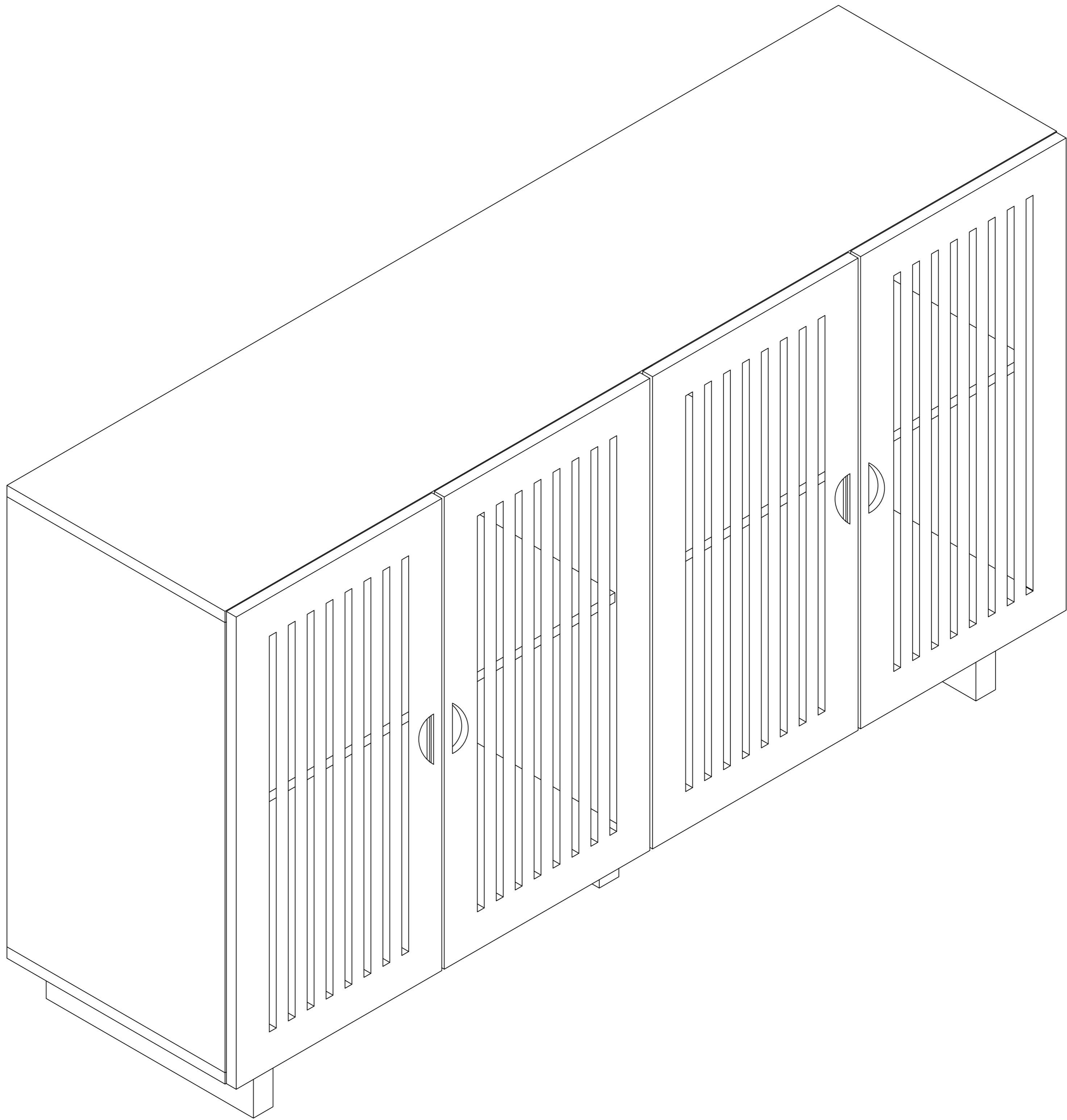

WF318109

ASSEMBLY INSTRUCTIONS

Item No : WF318109

Description : SIDEBOARD

Thank you for purchasing this quality product. Be sure to check all packing material carefully for small part that may have come loose inside carton during shipment.

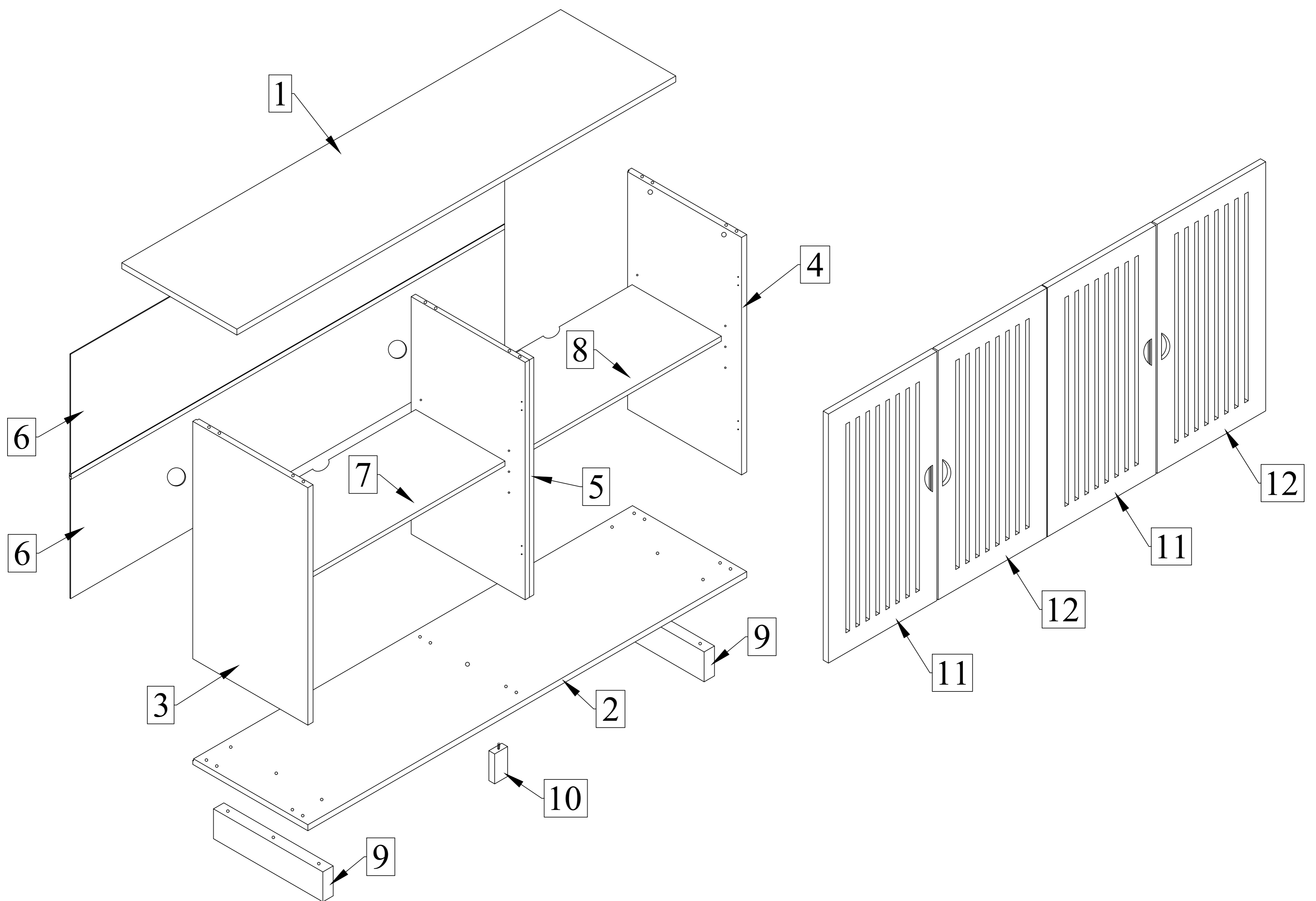

TOOLS REQUIRED (Not provided)

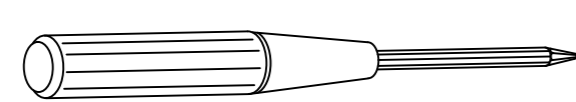

Screwdriver [Apply a battery screw machine for better assembly experience.]

Hardware List				Part List			
No.	Description	Sketch	Quantity	No.	Description	Sketch	Quantity
A	Wood Dowel M8x30MM		12PCS	1	Top Panel		1PC
B	Minifix + Cap	B1 B2	12SETS	2	Bottom Panel		1PC
C	Metal Shelf Support		8PCS	3	Side Panel - L		1PC
D	Magnet		4PCS	4	Side Panel - R		1PC
E	Iron Plate		4PCS	5	Center Panel		1PC
F	Soft Close Hinges 5/8		8PCS	6	Back Panel		2PCS
G	Screw M3.5 x 16MM		48PCS	7	Shelf A (725mm)		1PC
H	Screw M3 x 12MM		56PCS	8	Shelf B (740mm)		1PC
I	Screw M3 x 16MM		8PCS	9	Solid Leg		2PCS
J	JCBC M6 x 45MM		6PCS	10	Center Leg		1PC
K	Allen Key M4		1PC	11	Door Panel L		2PCS
L	H Connector		1PC	12	Door Panel R		2PCS

ASSEMBLY INSTRUCTIONS

Item No : WF318109

Description : SIDEBOARD

Thank you for purchasing this quality product. Be sure to check all packing material carefully for small part that may have come loose inside carton during shipment.

Step 1 : Attach Wood Dowel (A) and Minifix (B1) to parts (1,2,3,4,5) accordingly. Attach Metal Shelf Support (C) to Center & Side Panels (3,4,5). Attach Magnet (D) to Top Panel (1) with Screw (I). Attach Iron Plate (E) and Hinges (F) to Doors (11,12) with Screw (G,H).

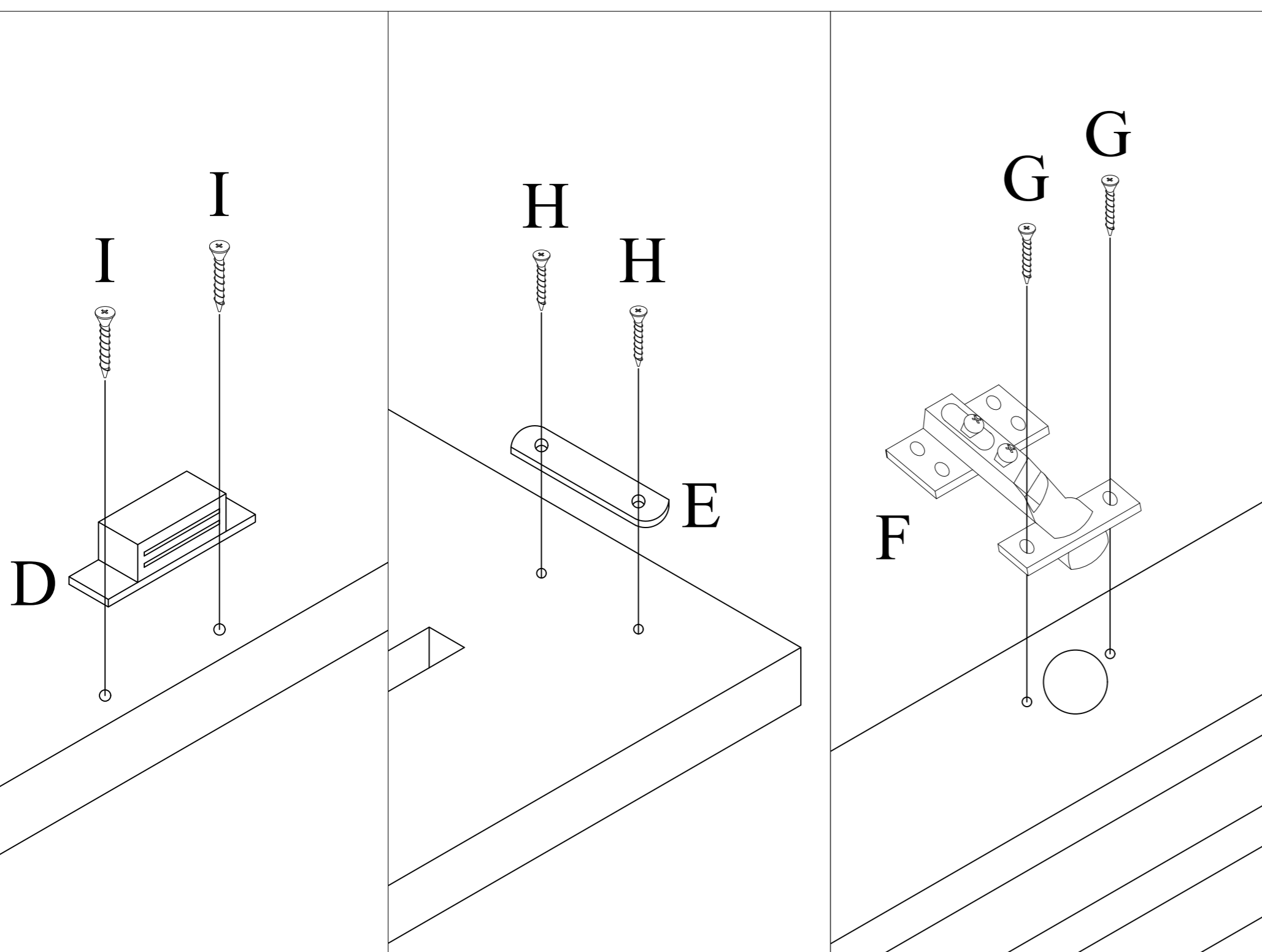
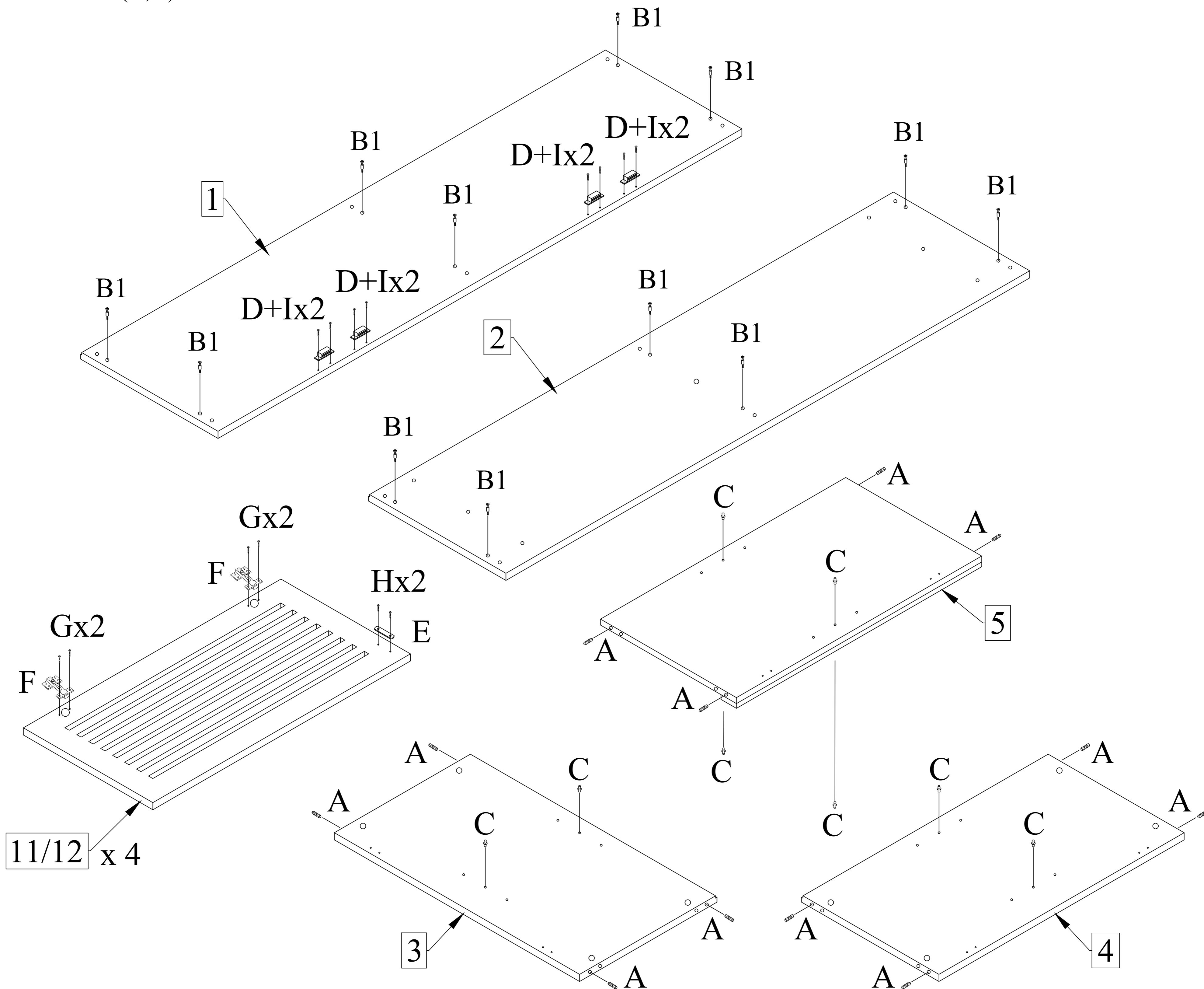

A	Wood Dowel M8x30MM		12PCS
B	Minifix + Cap	B1	12SETS
C	Metal Shelf Support		8PCS
D	Magnet		4PCS
E	Iron Plate		4PCS
F	Soft Close Hinges 5/8		8PCS
G	Screw M3.5 x 16MM		16PCS
H	Screw M3 x 12MM		8PCS
I	Screw M3 x 16MM		8PCS

ASSEMBLY INSTRUCTIONS



Item No : WF318109

Description : SIDEBOARD

Thank you for purchasing this quality product. Be sure to check all packing material carefully for small part that may have come loose inside carton during shipment.

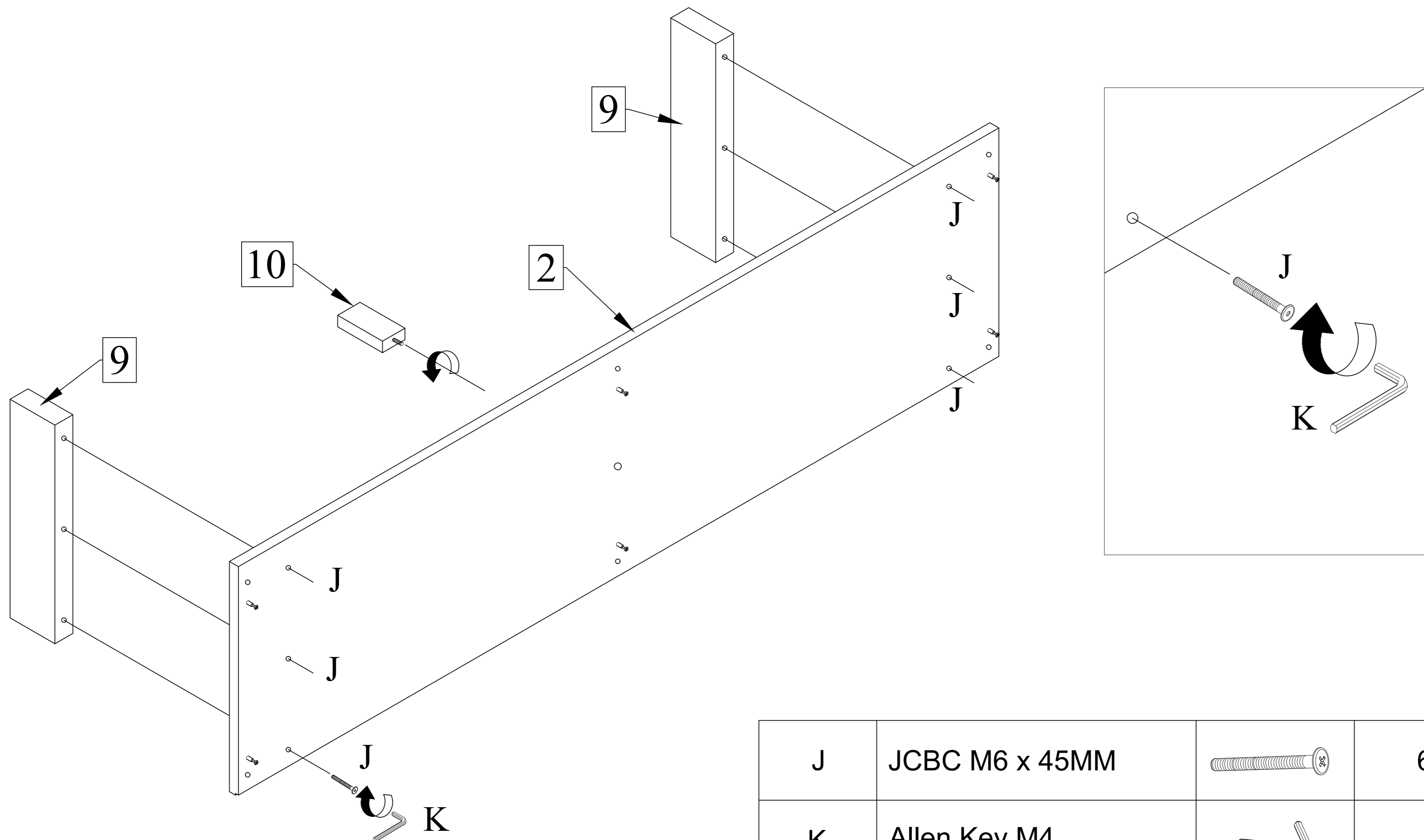
Step 2 : Attach Leg (9) onto Bottom Panel (2) with JCBC (J) using Allen Key (K). Twist Center Leg (10) in.

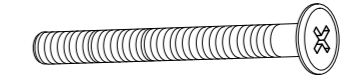

J	JCBC M6 x 45MM		6PCS
K	Allen Key M4		1PC

Step 3 : Connect Side & Center Panel (3,4,5) to Bottom Panel (2,9,10) and lock Minifix Cap (B2).

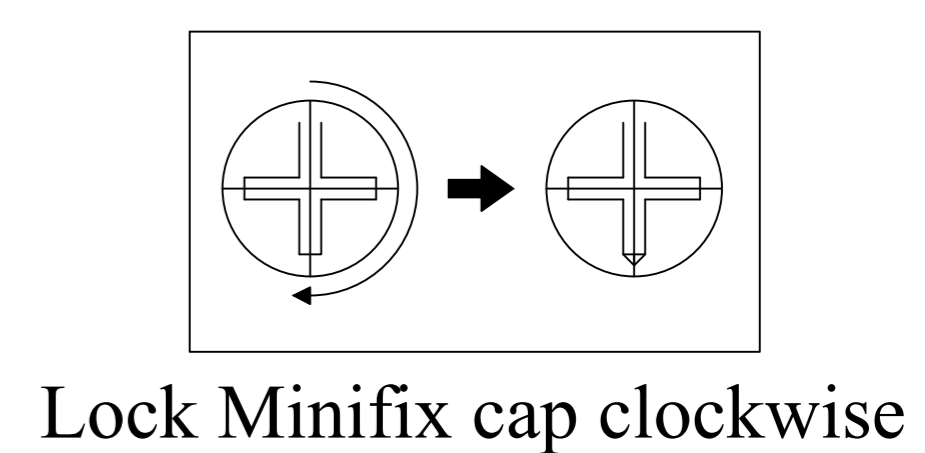
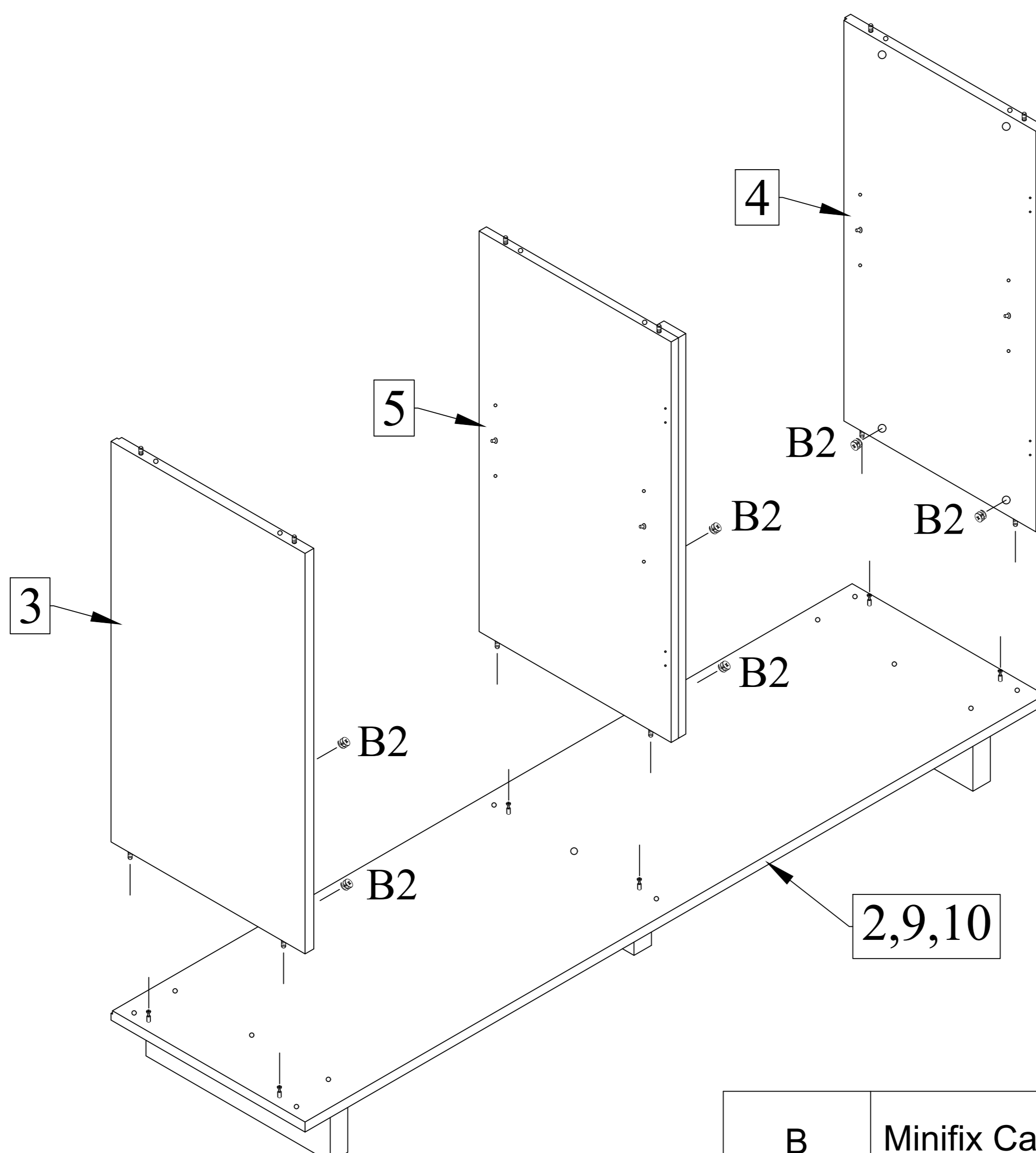

B	Minifix Cap	B2 	6PCS
---	-------------	--	------

ASSEMBLY INSTRUCTIONS

Item No : WF318109

Description : SIDEBOARD

Thank you for purchasing this quality product. Be sure to check all packing material carefully for small part that may have come loose inside carton during shipment.

Step 4 : Attach Top Panel (1) to the assembled parts and lock Minifix Cap (B2)

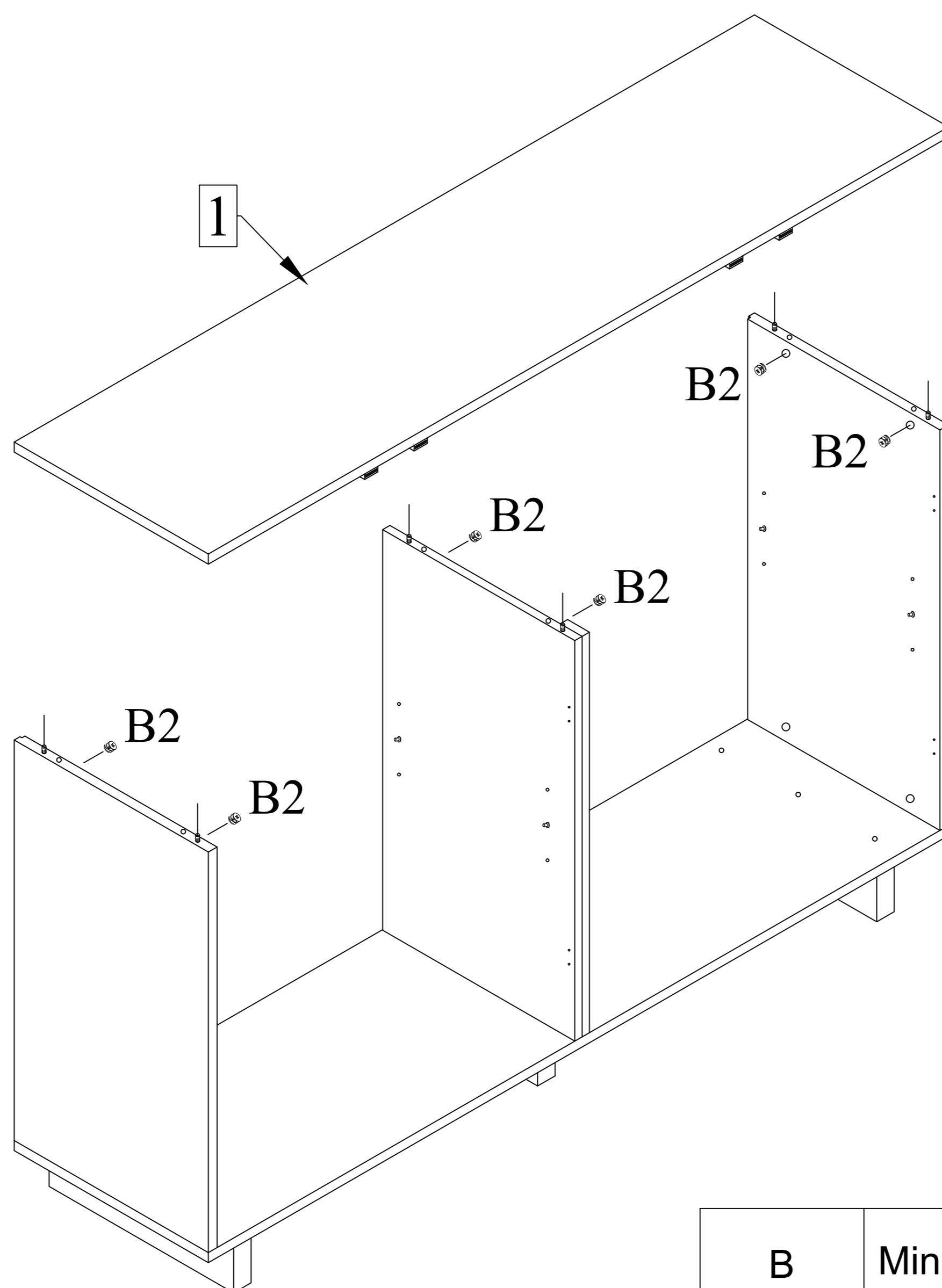



Lock Minifix cap clockwise

B	Minifix Cap	B2 	6PCS
---	-------------	--	------

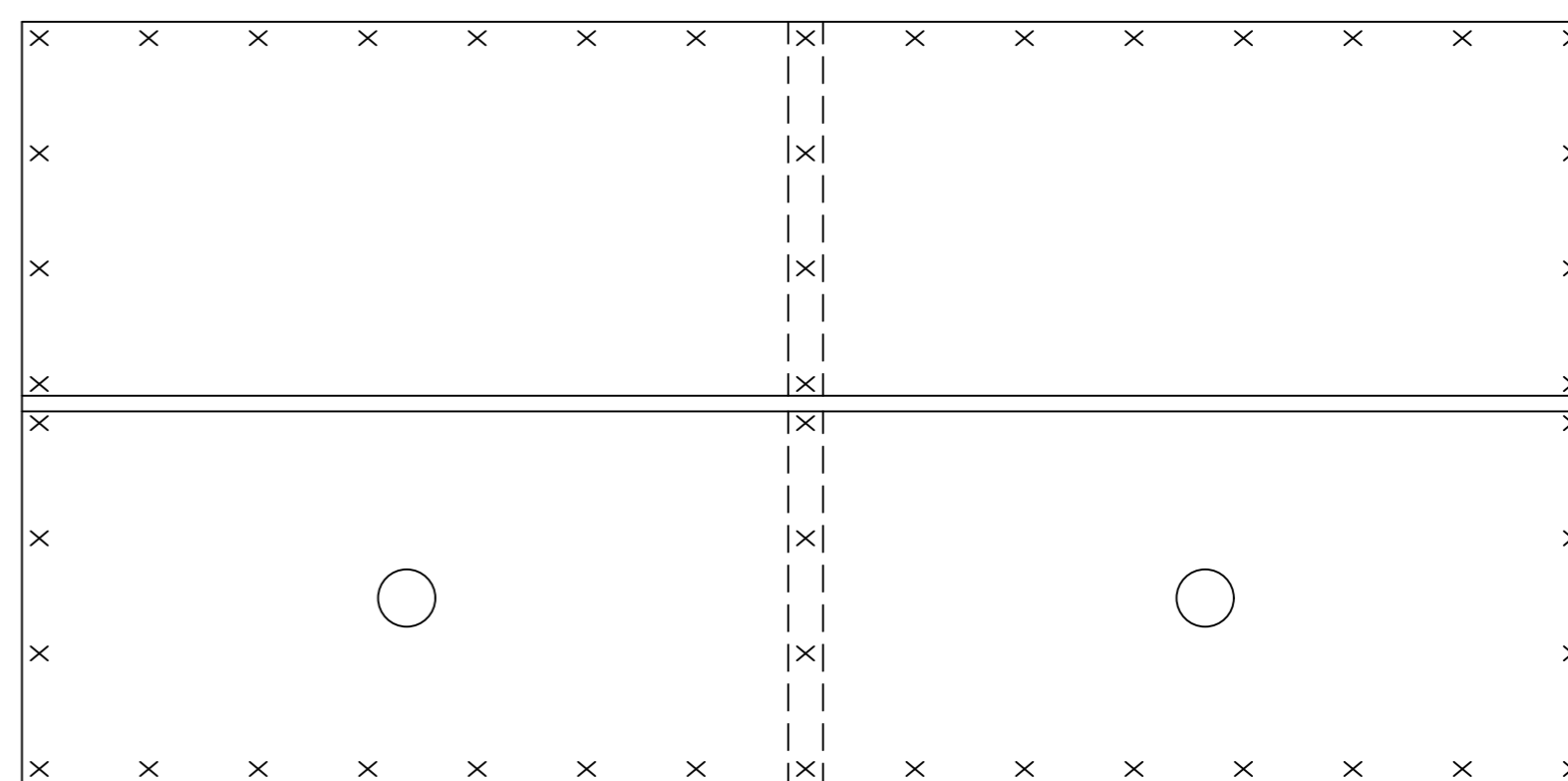
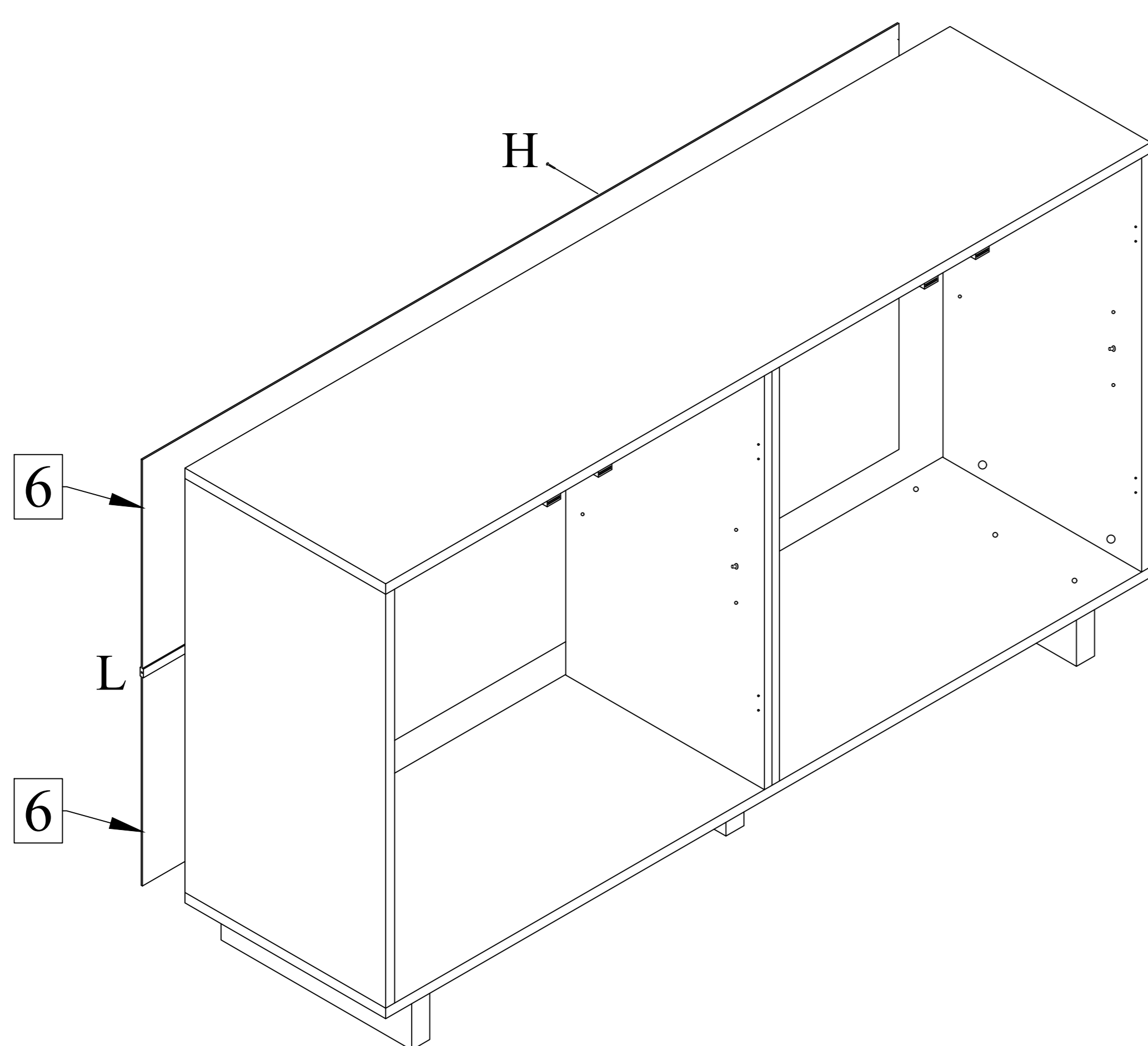
Step 5 : Slot Back Panel (6) into H Connector (L) and attach it from behind using Screw (H).

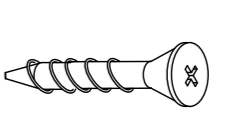

Guidance of screw array

H	Screw M3 x 12MM		48PCS
L	H Connector		1PC

ASSEMBLY INSTRUCTIONS

Item No : WF318109

Description : **SIDEBOARD**

Thank you for purchasing this quality product. Be sure to check all packing material carefully for small part that may have come loose inside carton during shipment.

Step 6 : Insert Shelves (7,8). Please note the length of the shelves, bigger shelf (8) should be on right side from front view.

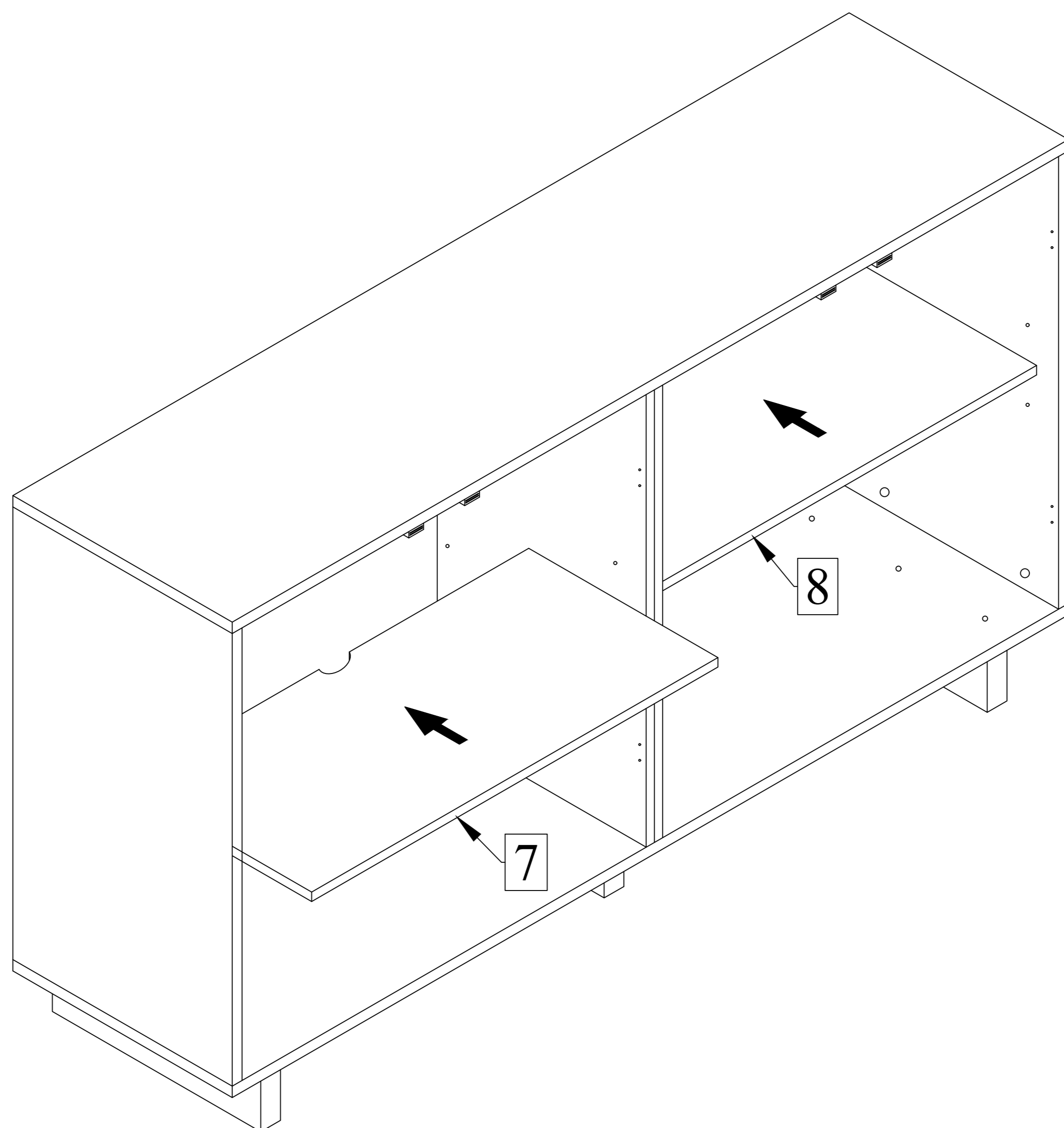

Step 7 : Attach Doors (11,12) using Screw (G). Completed Assembly.

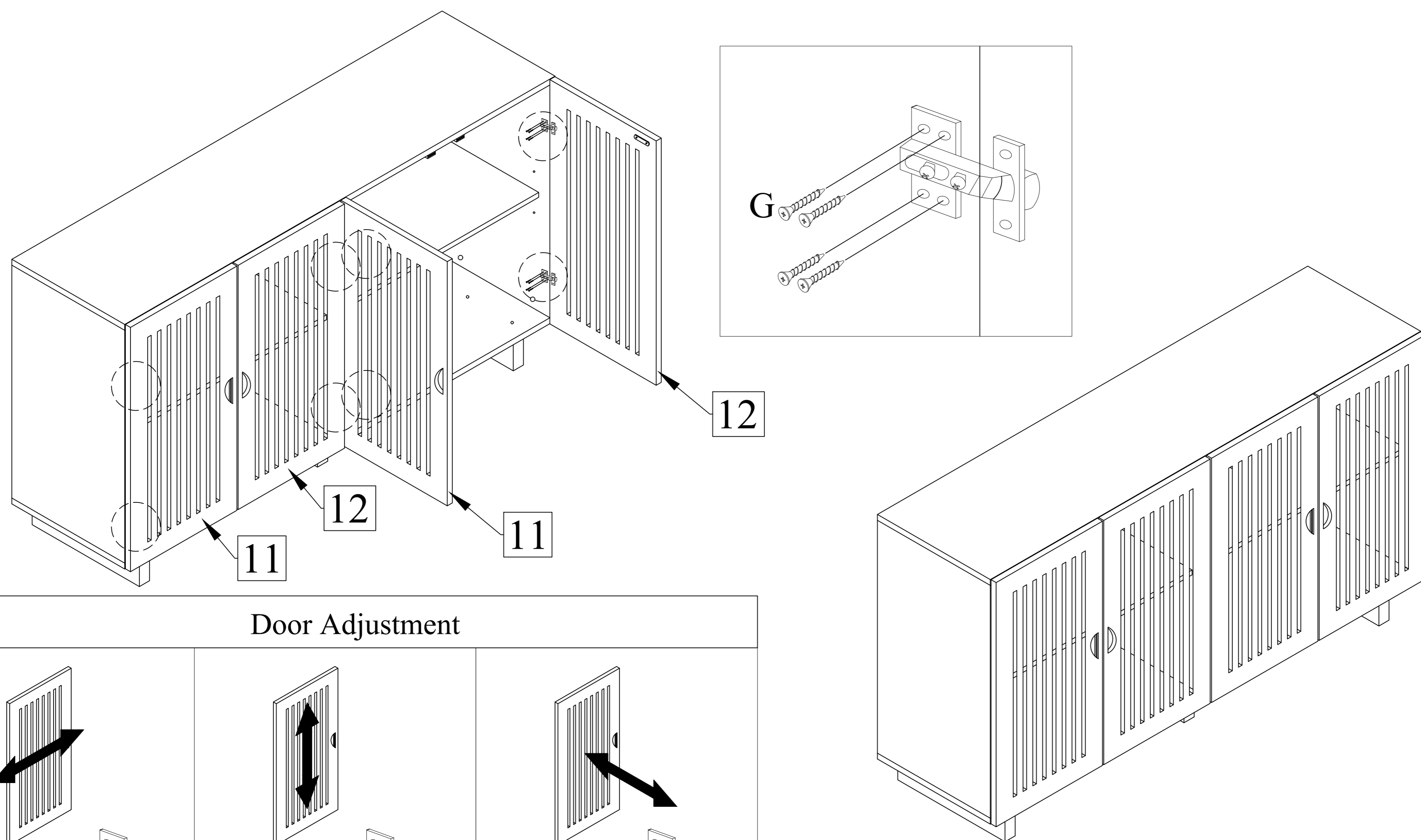

Door Adjustment

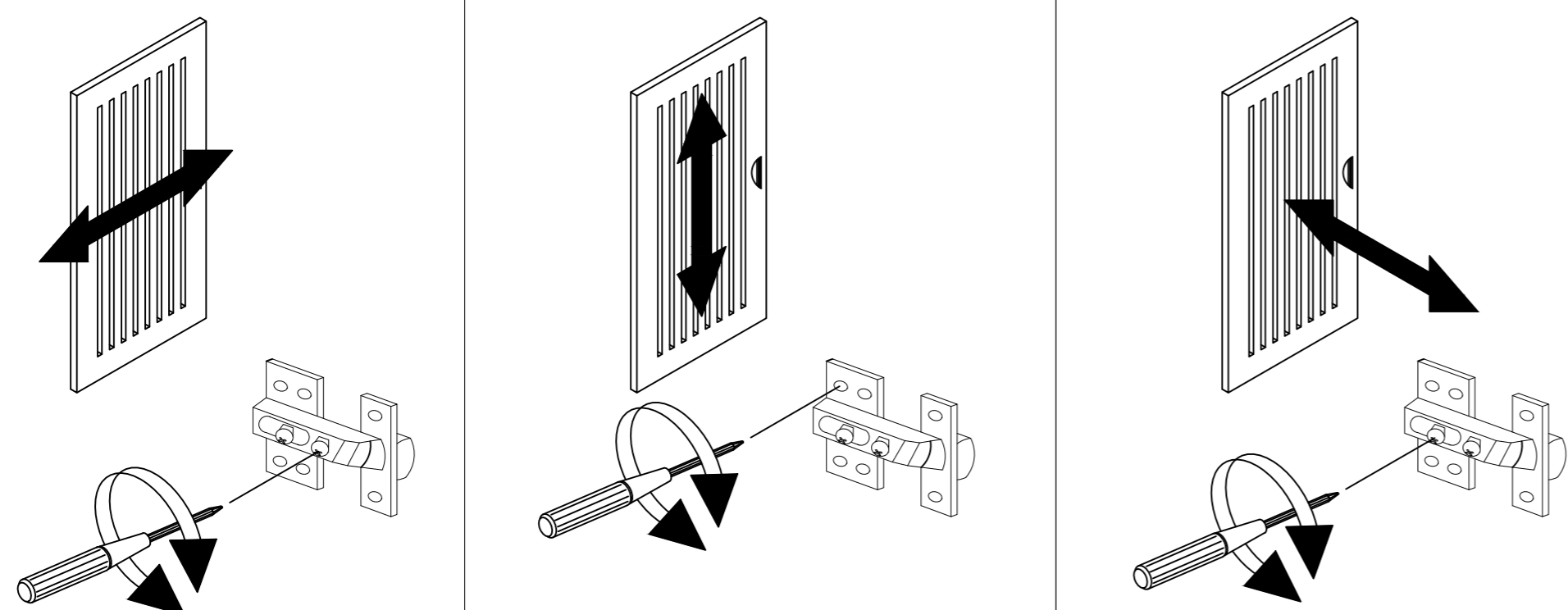

G

Screw M3.5 x 16MM

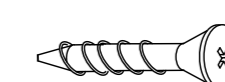

32PCS