

# ASSEMBLY INSTRUCTIONS

**Item No : WF318154**

**Description : SIDEBOARD**

Thank you for purchasing this quality product. Be sure to check all packing material carefully for small part that may have come loose inside carton during shipment.

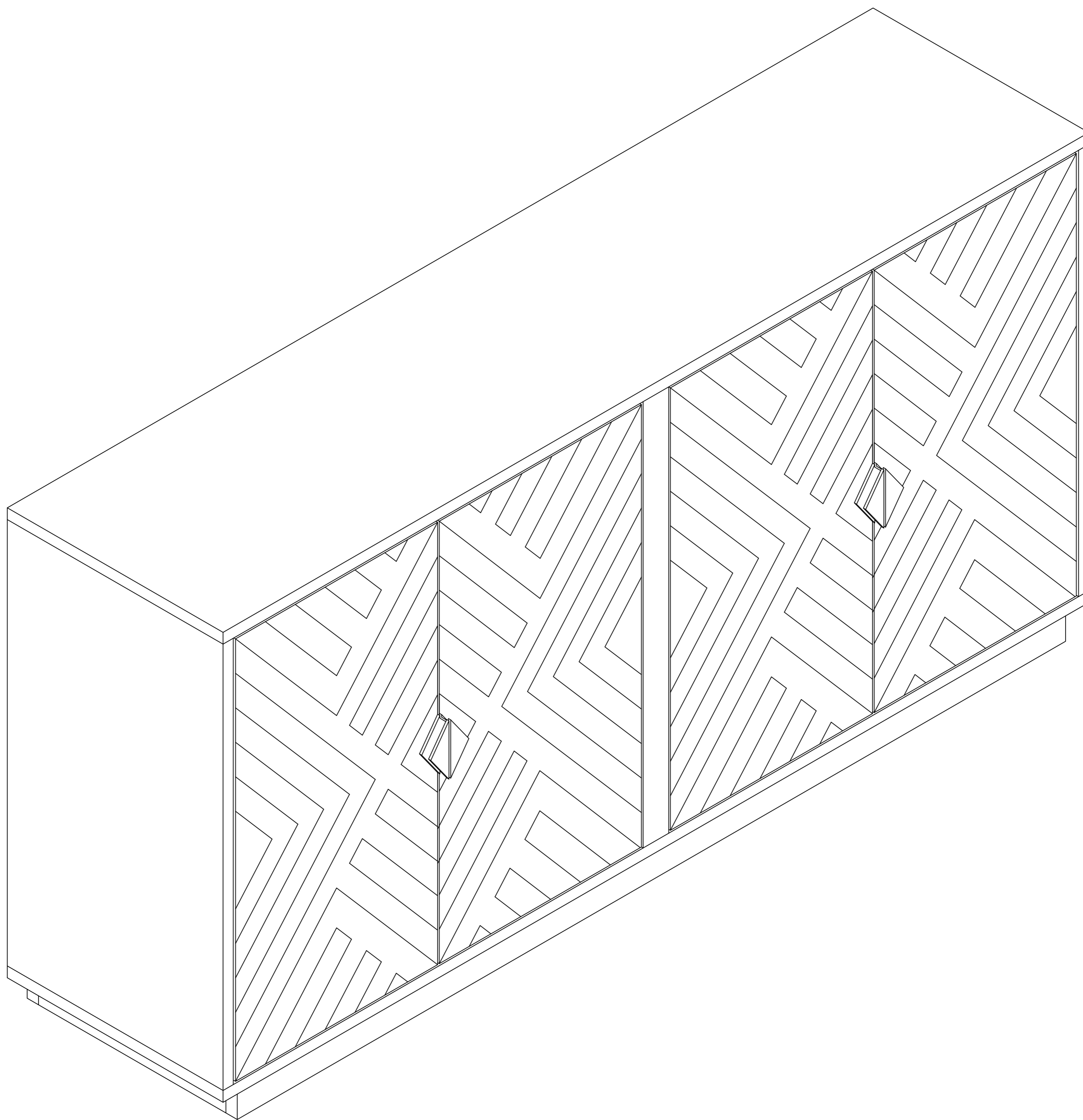

**WF318154**

# ASSEMBLY INSTRUCTIONS

Item No : WF318154

Description : SIDEBOARD

Thank you for purchasing this quality product. Be sure to check all packing material carefully for small part that may have come loose inside carton during shipment.

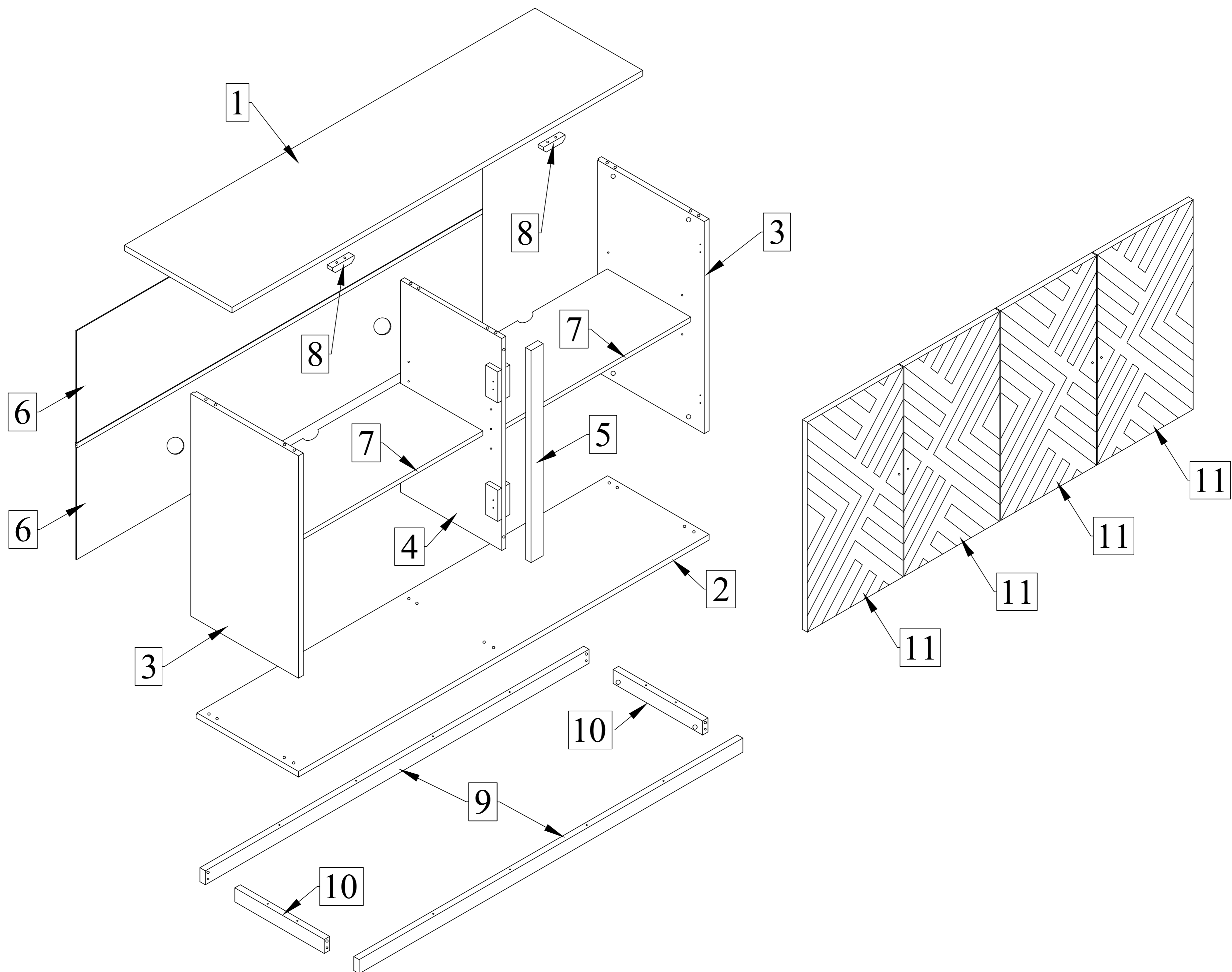

## TOOLS REQUIRED (Not provided)

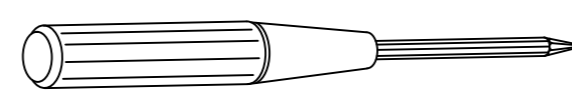

Screwdriver

Hardware List				Part List			
No.	Description	Sketch	Quantity	No.	Description	Sketch	Quantity
A	Wood Dowel M8x30MM		18PCS	1	Top Panel		1PC
B	Minifix + Cap	B1  B2	18SETS	2	Bottom Panel		1PC
C	Metal Shelf Support		8PCS	3	Side Panel		2PCS
D	Screw M4 x 32MM		16PCS	4	Center Panel		1PC
E	Soft Close Hinges 7/8		8PCS	5	Center Rail		1PC
F	Screw M3.5 x 16MM		48PCS	6	Back Panel		2PCS
G	Screw M3 x 12MM		48PCS	7	Shelf		2PCS
H	H Connector		1PC	8	Door Stopper		2PCS
I	Handle with Screw		4SETS	9	Leg Frame		2PCS
				10	Leg Frame		2PCS
				11	Door Panel		4PCS

Apply a battery screw machine for better assembly experience.

# ASSEMBLY INSTRUCTIONS

Item No : WF318154

Description : SIDEBOARD

Thank you for purchasing this quality product. Be sure to check all packing material carefully for small part that may have come loose inside carton during shipment.

Step 1 : Attach Wood Dowel (A) and Minifix (B1) to parts (1,2,3,4,5,9,10) accordingly. Attach Metal Shelf Support (C) to Center & Side Panels (3,4). Attach Door Stopper (8) to Top Panel (1) using Screw (D). Attach Hinges (E) to Doors (11) with Screw (F).

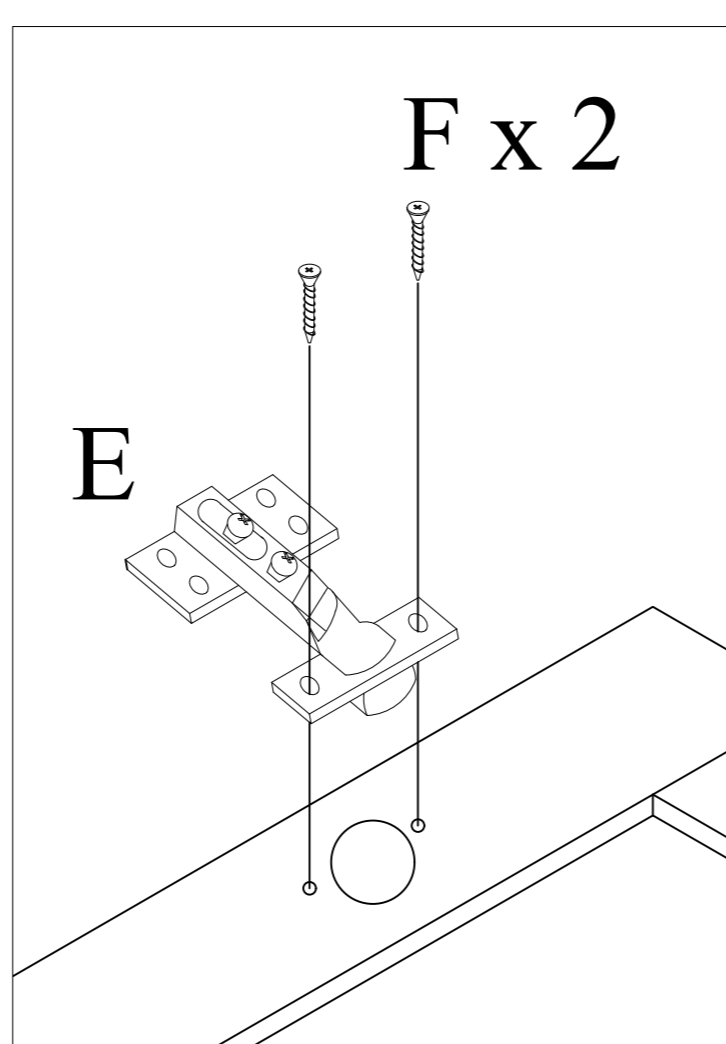
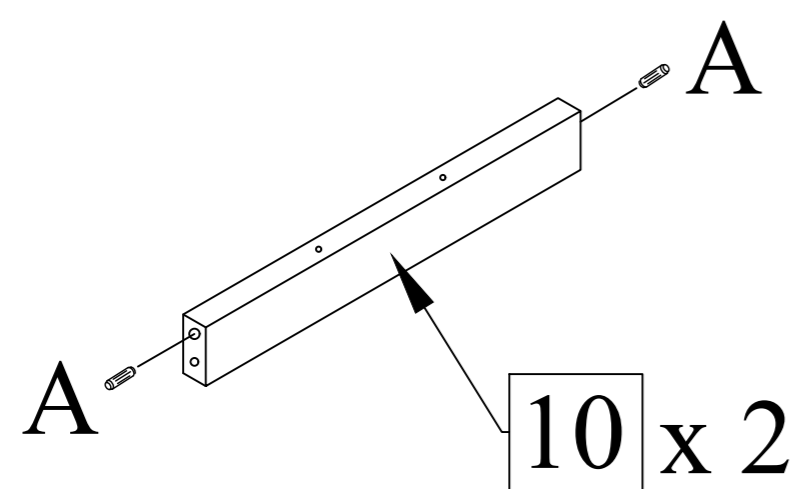
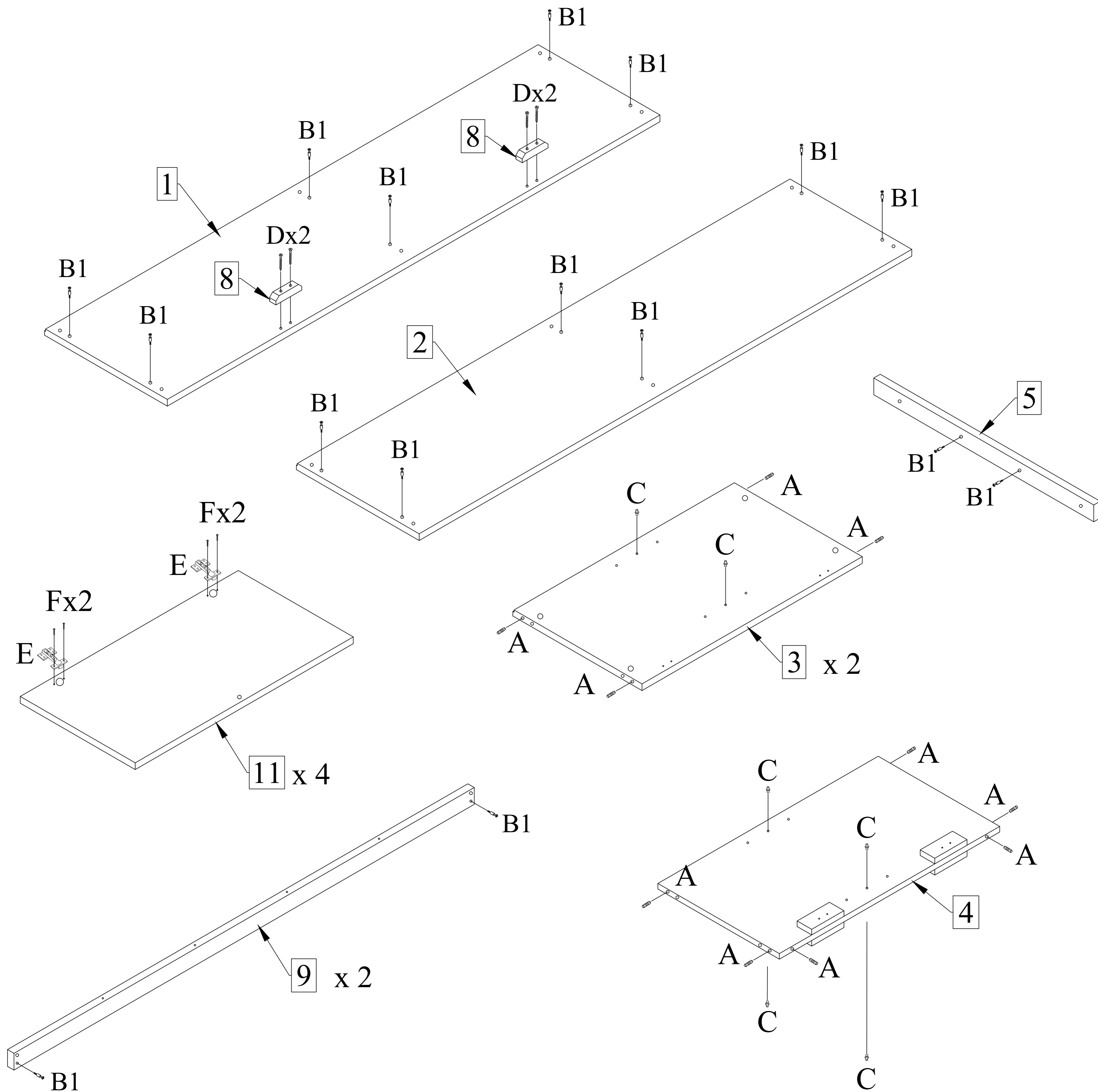

A	Wood Dowel M8x30MM		18PCS
B	Minifix + Cap		18PCS
C	Metal Shelf Support		8PCS
D	Screw M4 x 32MM		4PCS
E	Soft Close Hinges 7/8		8PCS
F	Screw M3.5 x 16MM		16PCS

# ASSEMBLY INSTRUCTIONS

Item No : WF318154

Description : SIDEBOARD

Thank you for purchasing this quality product. Be sure to check all packing material carefully for small part that may have come loose inside carton during shipment.

Step 2 : Attach Center Rail (5) to Center Panel (4) and lock Minifix Cap (B2). Connect Leg Frame (9,10) and lock Minifix Cap (B2). Attach the frame onto Bottom Panel (2) using screw (D).

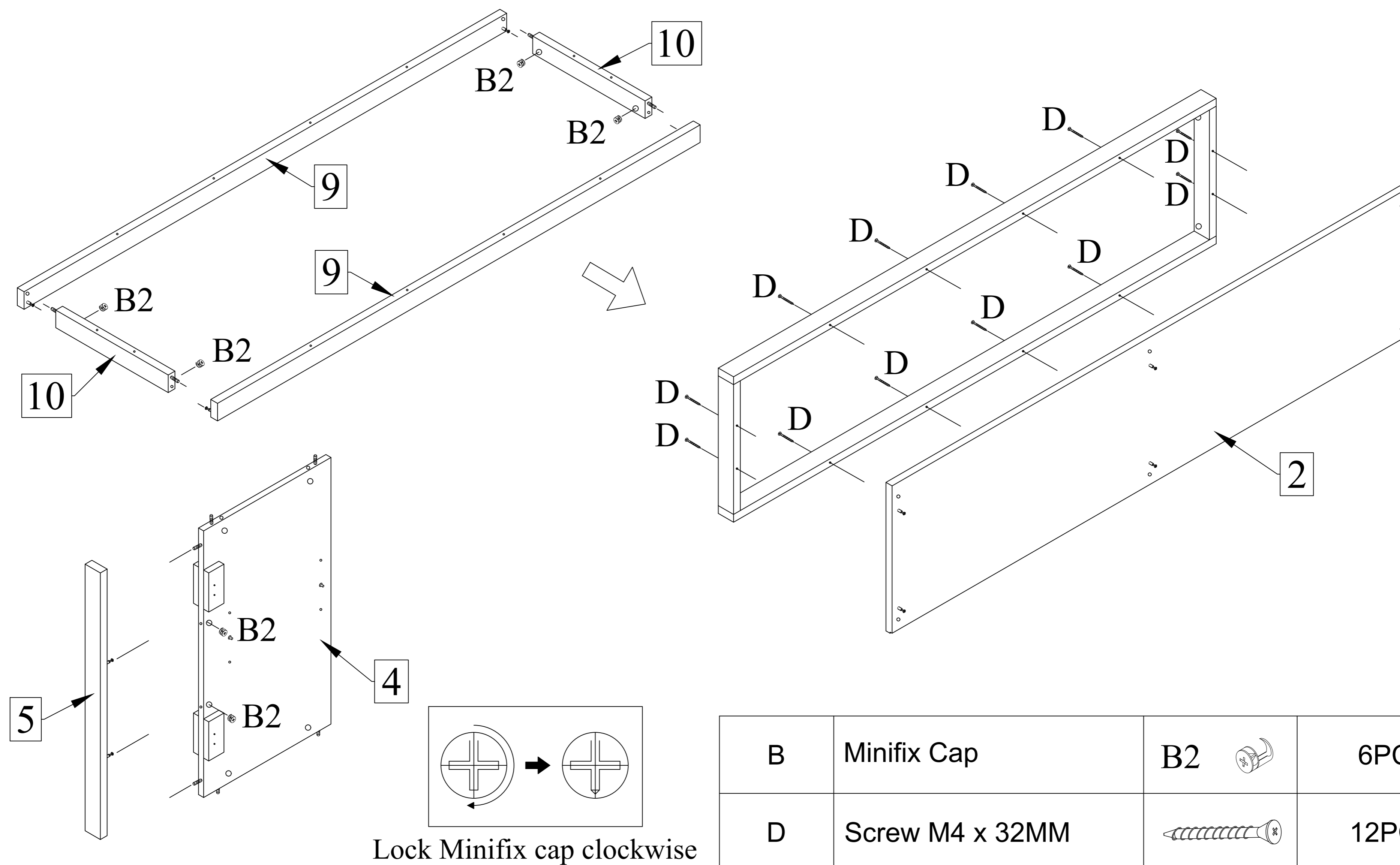

Step 3 : Connect Side & Center Panel (3,4,5) to Bottom Panel (2,9,10) and lock Minifix Cap (B2).

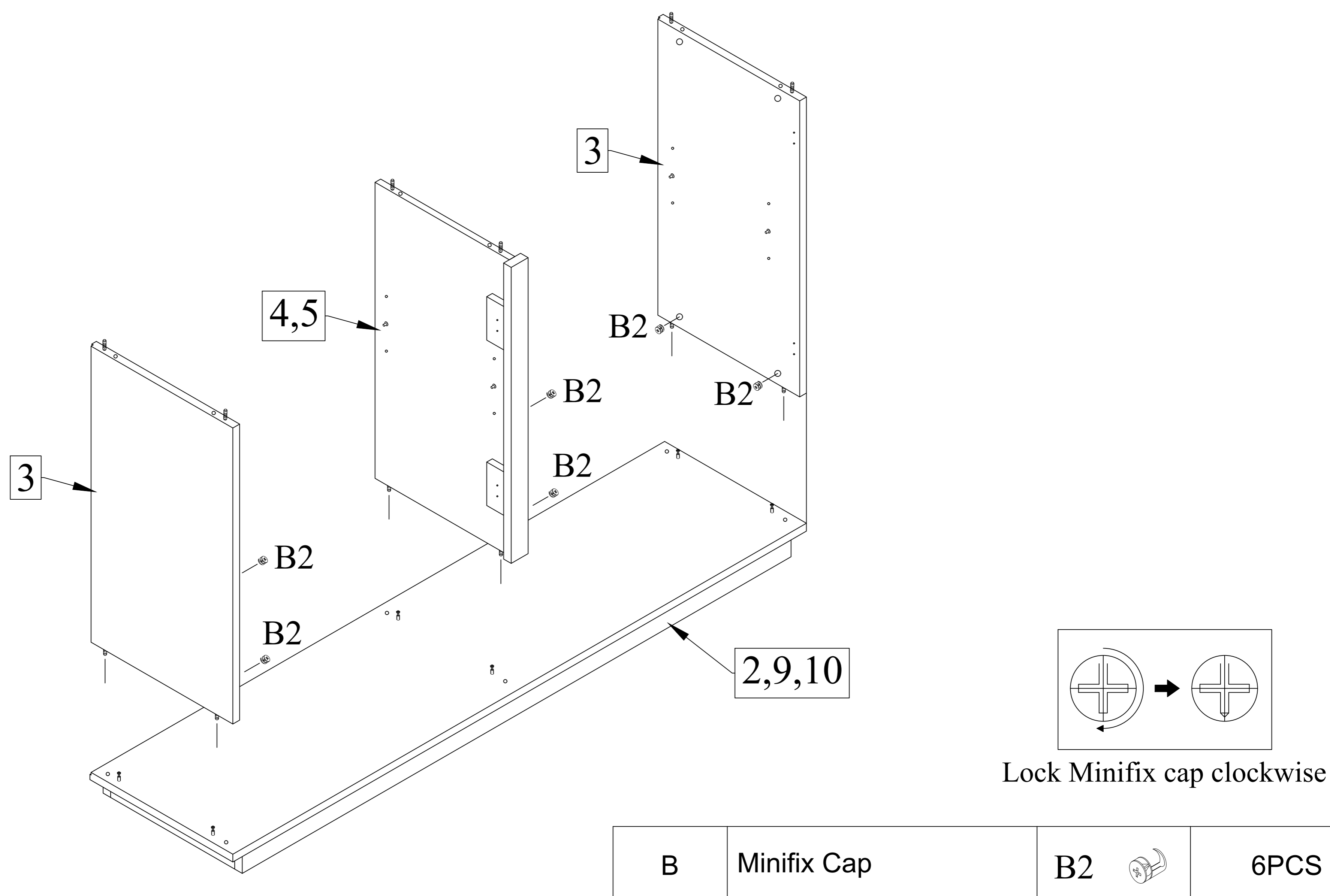

# ASSEMBLY INSTRUCTIONS

Item No : WF318154

Description : SIDEBOARD

Thank you for purchasing this quality product. Be sure to check all packing material carefully for small part that may have come loose inside carton during shipment.

Step 4 : Attach Top Panel (1,8) to the assembled parts and lock Minifix Cap (B2)

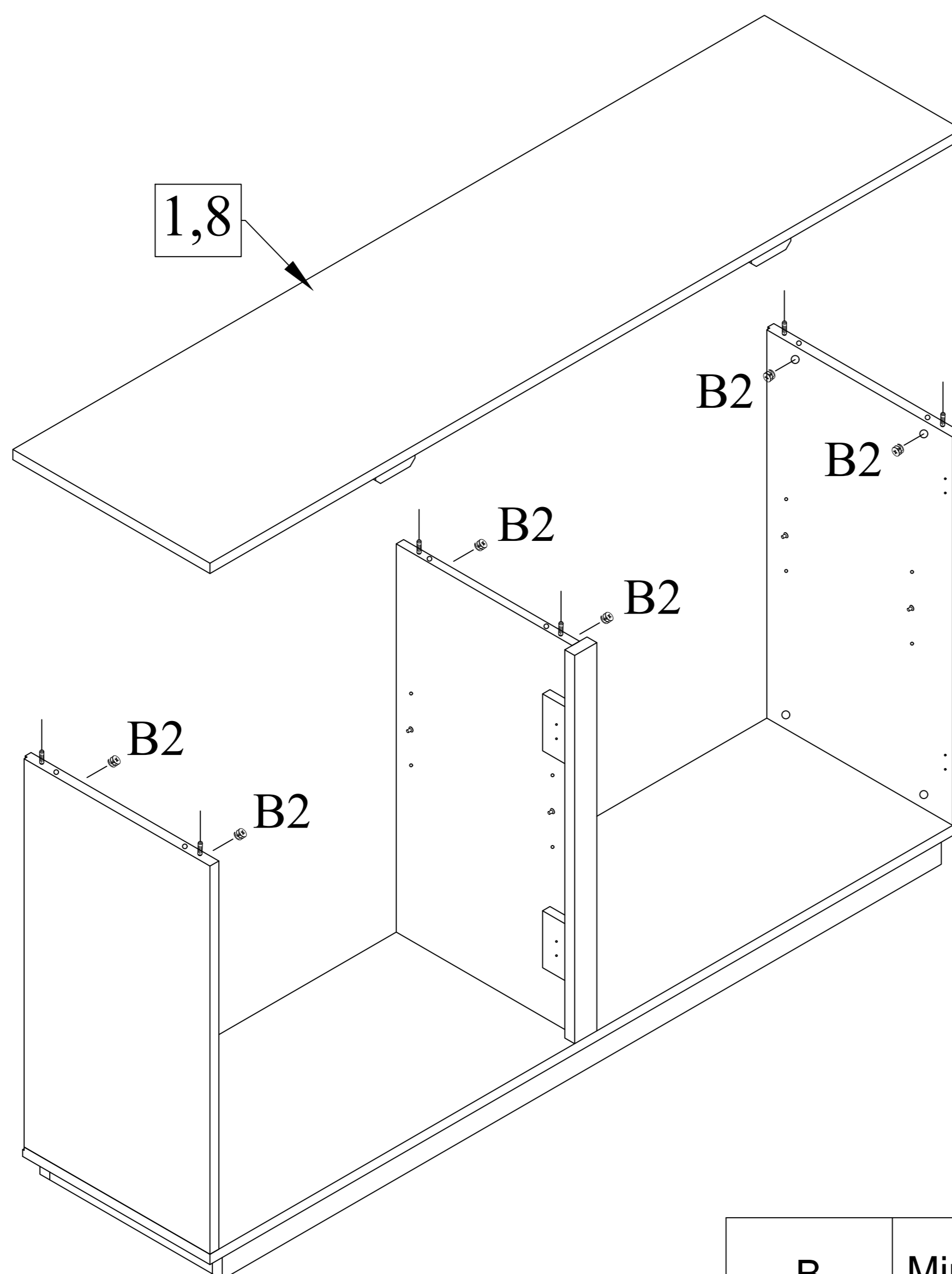



Lock Minifix cap clockwise

B	Minifix Cap	B2 	6PCS
---	-------------	--	------

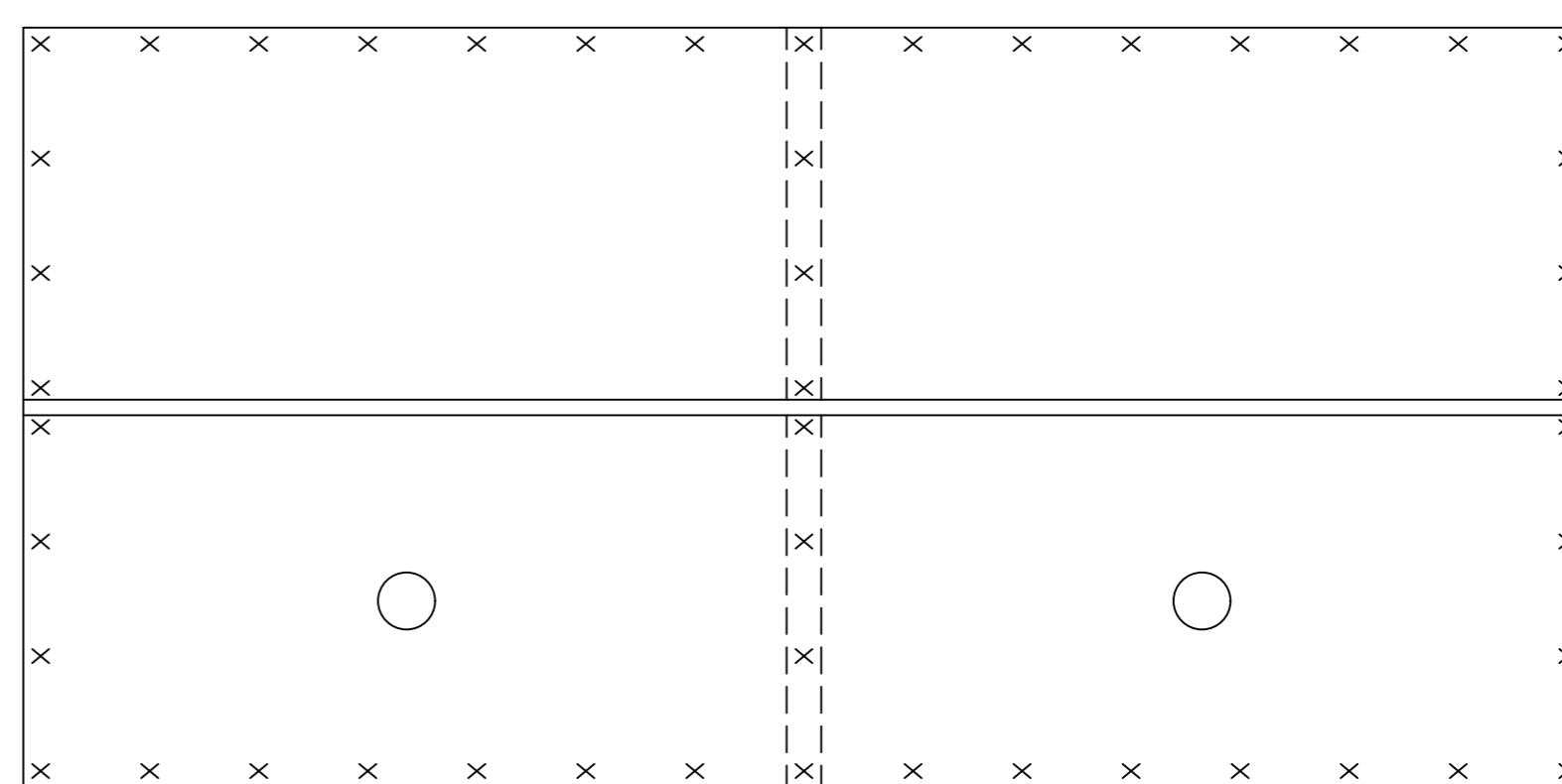
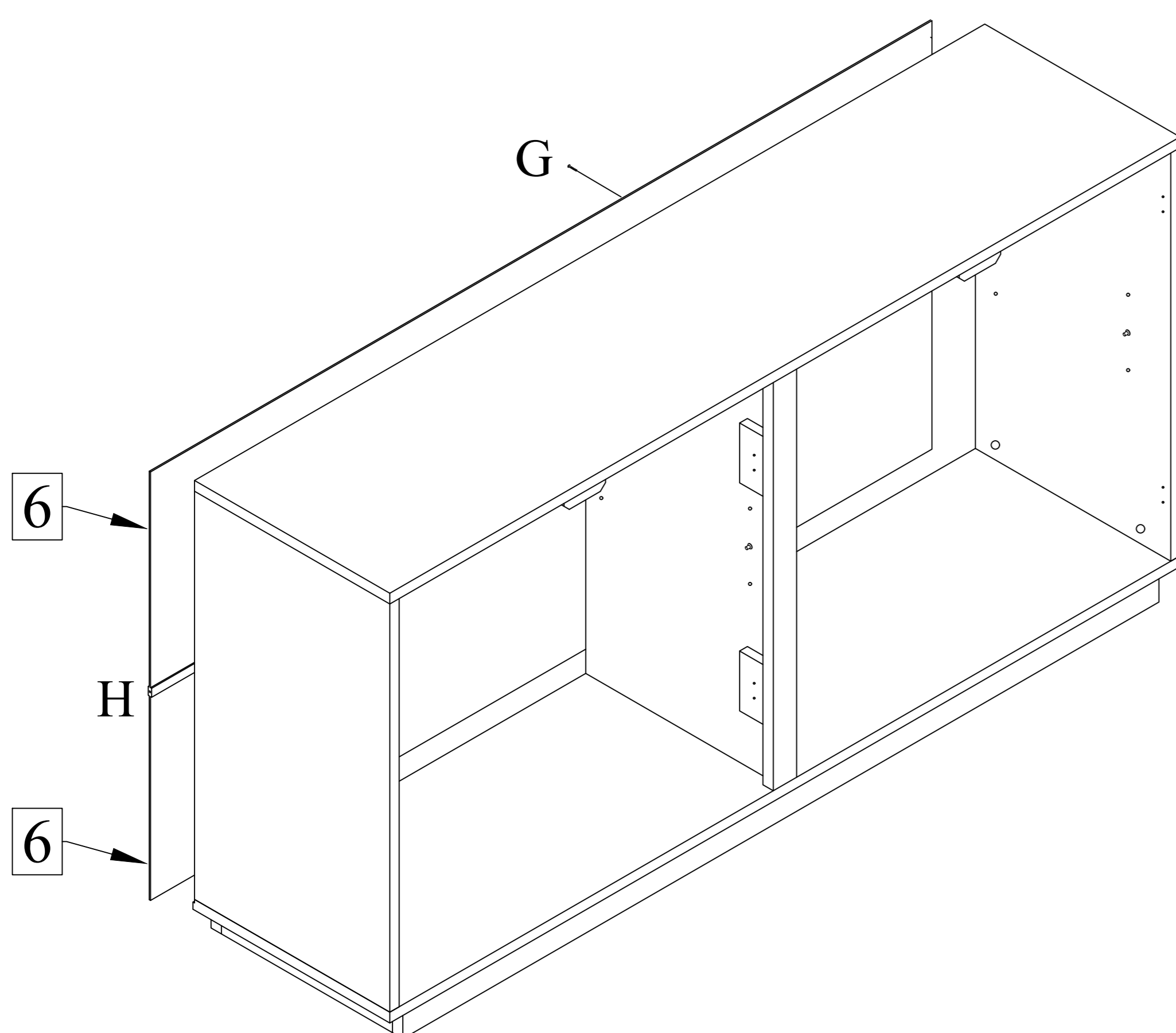
Step 5 : Slot Back Panel (6) into H Connector (H) and attach it from behind using Screw (G).

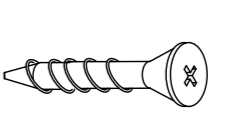

Guidance of screw array

G	Screw M3 x 12MM		48PCS
H	H Connector		1PC

# ASSEMBLY INSTRUCTIONS

Item No : WF318154

Description : SIDEBOARD

Thank you for purchasing this quality product. Be sure to check all packing material carefully for small part that may have come loose inside carton during shipment.

Step 6 : Insert Shelves (7).

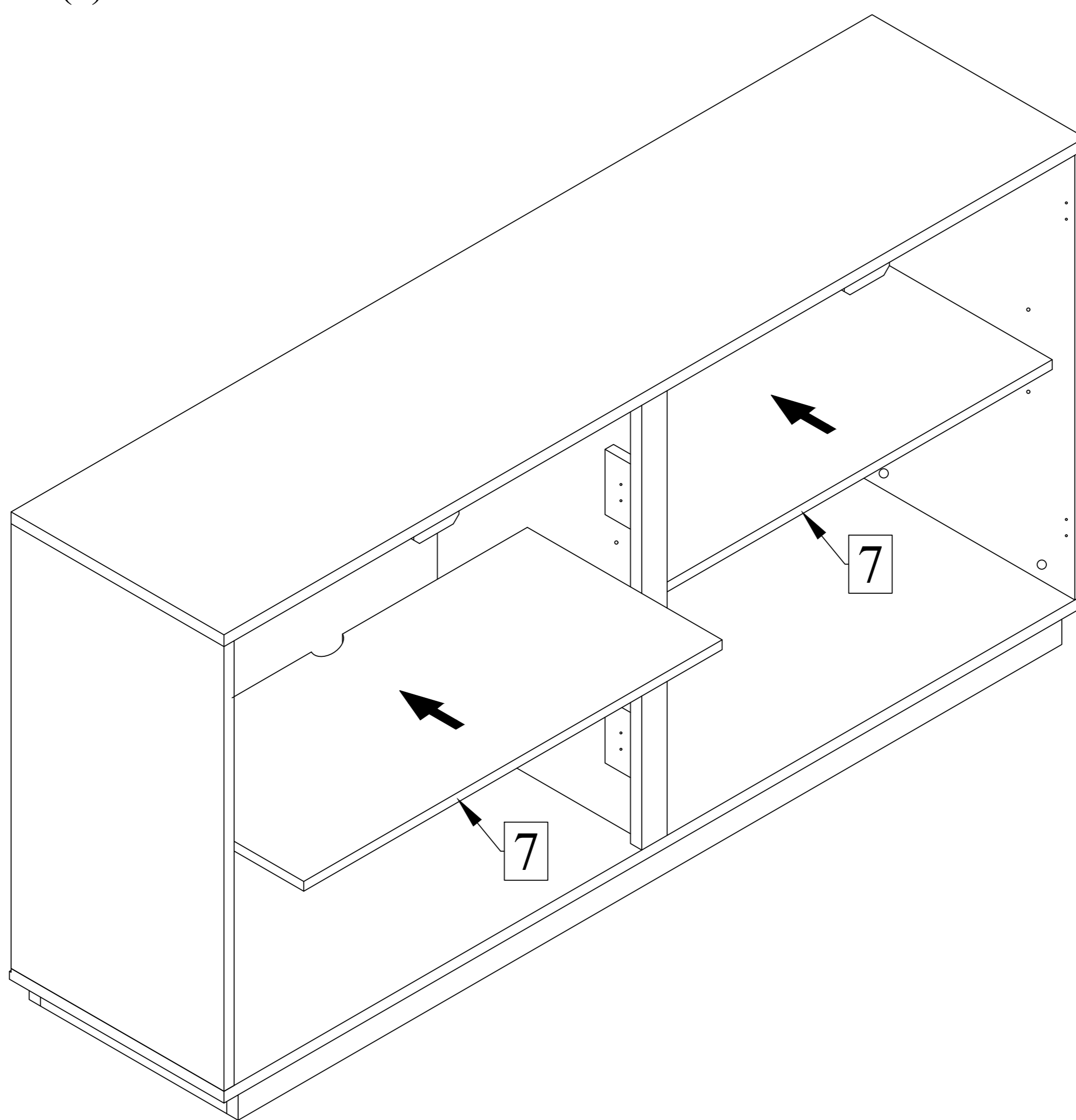

Step 7 : Attach Doors (11) using Screw (F). Attach Handle (I). Completed Assembly.

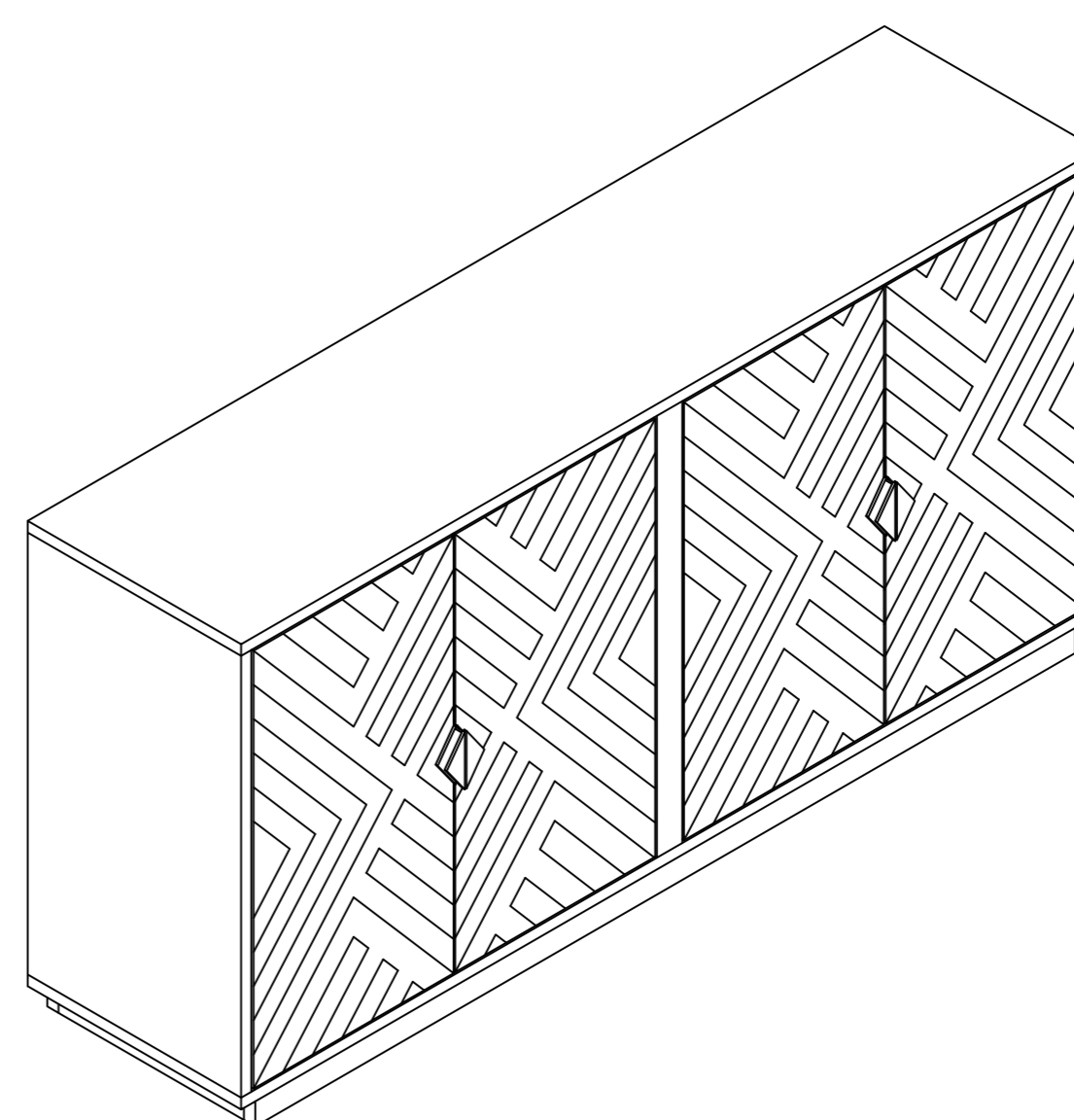
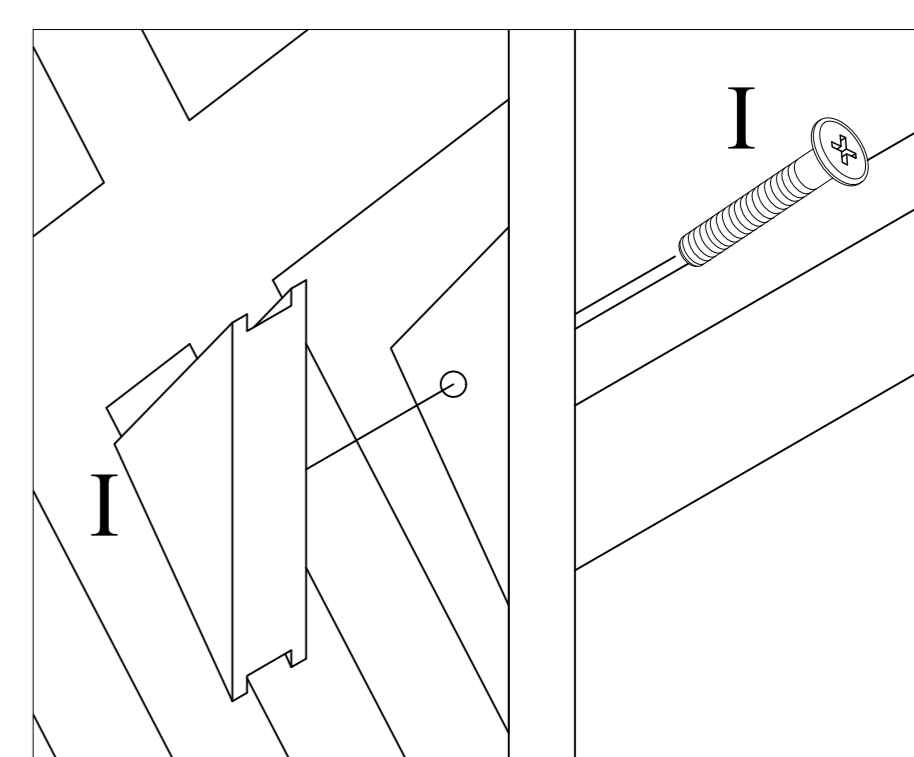
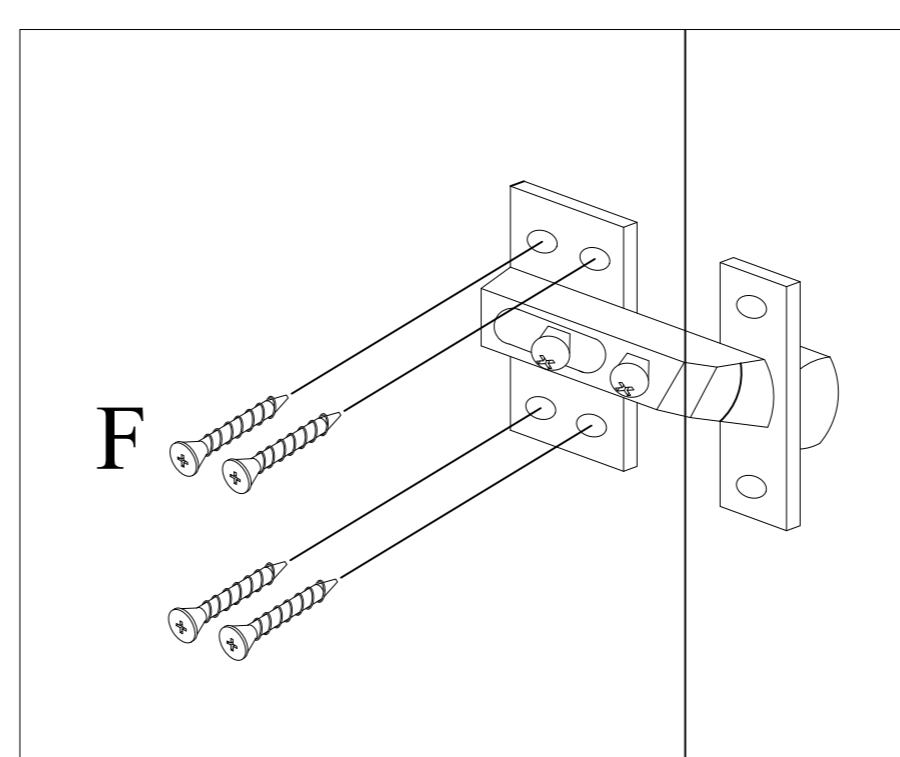
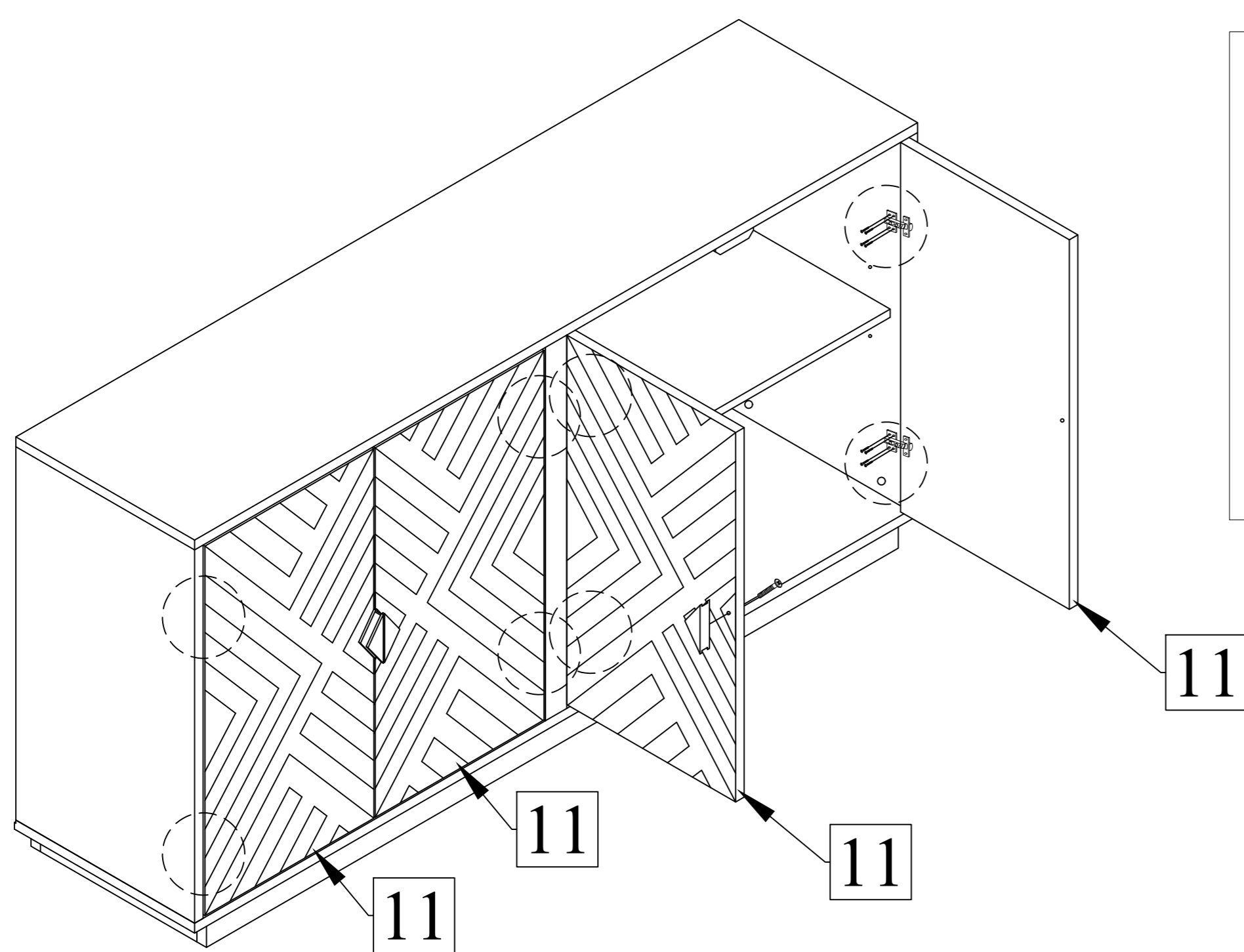

### Door Adjustment

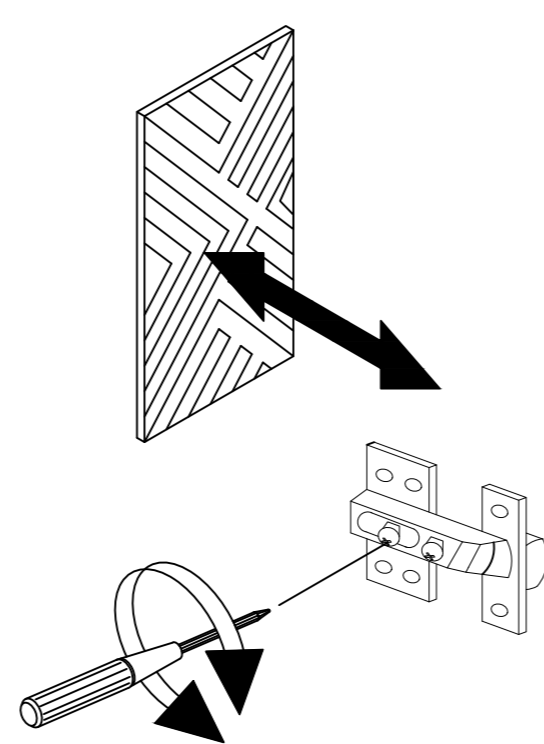
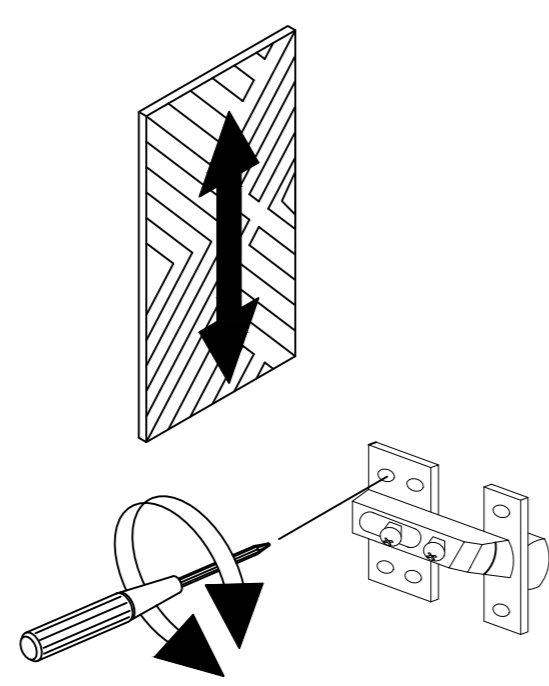
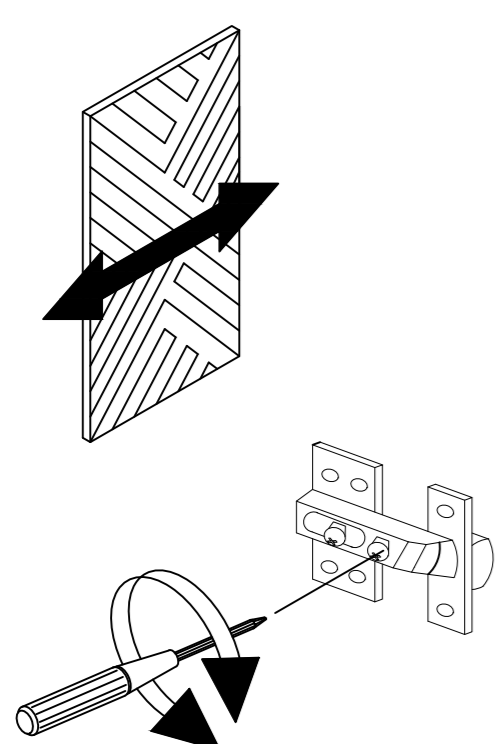

F

Screw M3.5 x 16MM

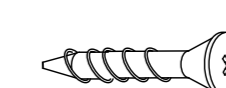

32PCS

I

Handle with Screw



4SETS