

ASSEMBLY INSTRUCTION
ITEM:WF318593 / WF318594

DINING TABLE

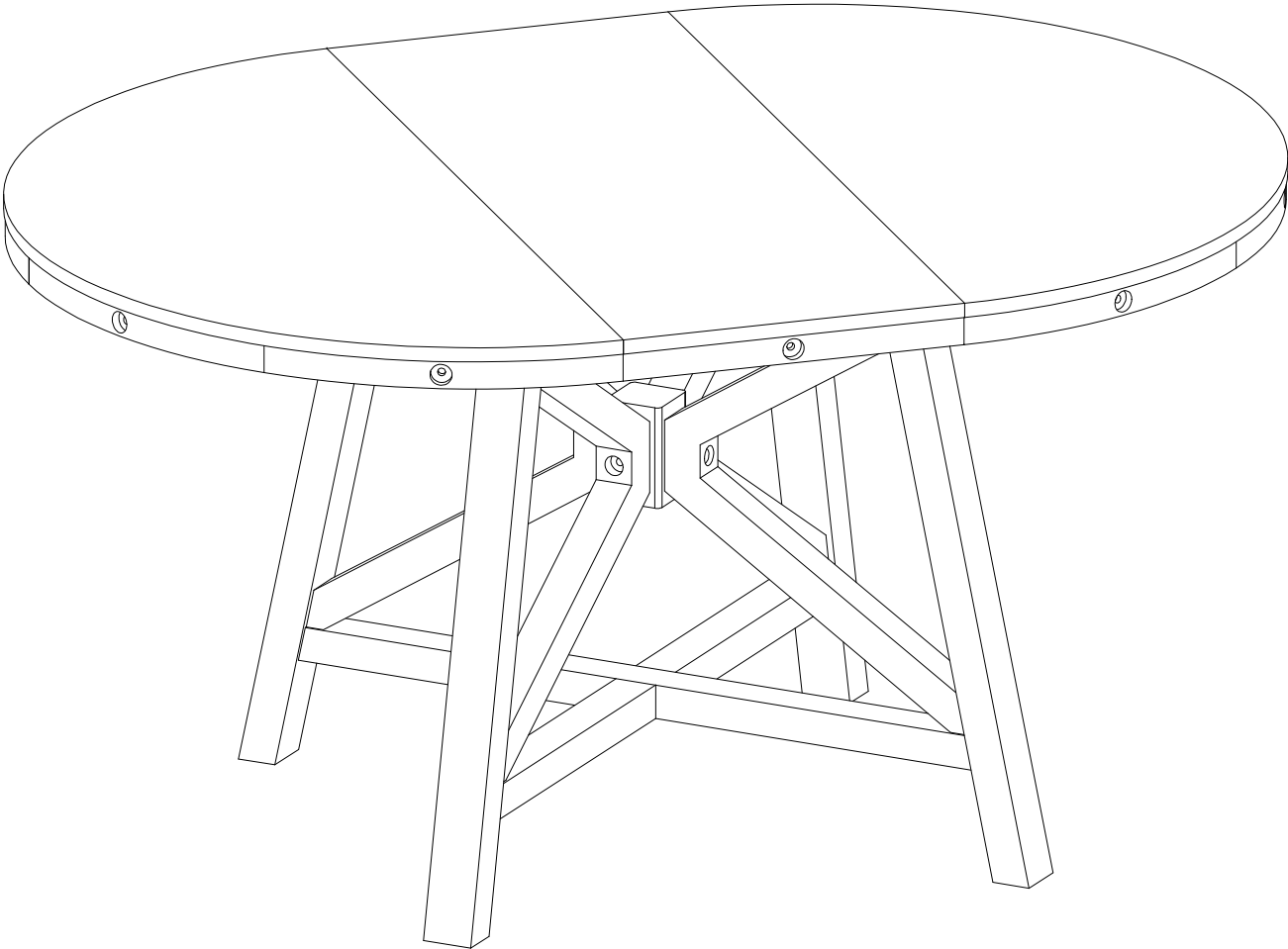

Please read these instructions fully before starting assembly:

1. Place all wooden parts on a clean and smooth surface such as arug or carpet to avoid scratching the parts.
2. Kindly follow the assembly instructions step by step.
3. Do not tighten all screws and bolts until the table is fully assembled.
4. Unscrew the protective plastique supports from the metal insert of the legs before assembly.
5. Parts of the assembly will be easier with 2 people.

Care and maintenance:





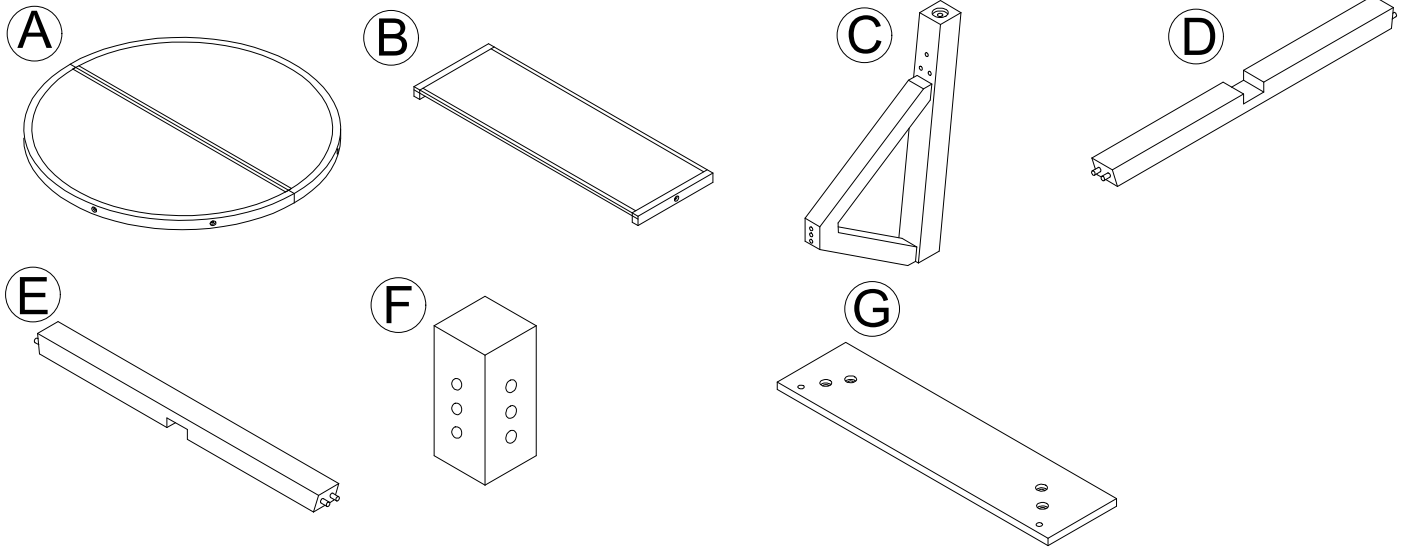





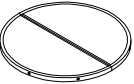

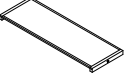

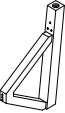

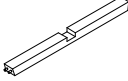
Only clean using a damp cloth and mild detergent, do no use bleach or abrasive cleaners.

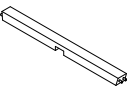
ASSEMBLY INSTRUCTION
ITEM: WF318593 / WF318594

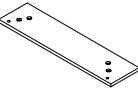

Part List For One

Hardware List For One





A		TOP TABLE (1PC)	1	 Ø5/16"x38mm	BOLT (16PCS)
B		TABLE LEAF (1PC)	2	 Ø5/16"x13mm	SPRING WASHER (16PCS)
C		TABLE LEG (4PCS)	3	 Ø5/16"x19mm	FLAT WASHER (16PCS)
D		LOWER FOOT (1PC)	4	 Ø1/4"x20mm	BOLT (8PCS)
E		UPPER FOOT (1PC)	5	 Ø1/4"x11mm	SPRING WASHER (8PCS)
F		FINIAL (1PC)	6	 Ø1/4"x19mm	FLAT WASHER (8PCS)
G		CONNECTION PANEL (2PCS)	7		L METAL BRACKET (4PCS)
			8	 M4	ALLEN KEY (1PC)
			9		WOOD DOWEL (8PCS)

ASSEMBLY INSTRUCTION

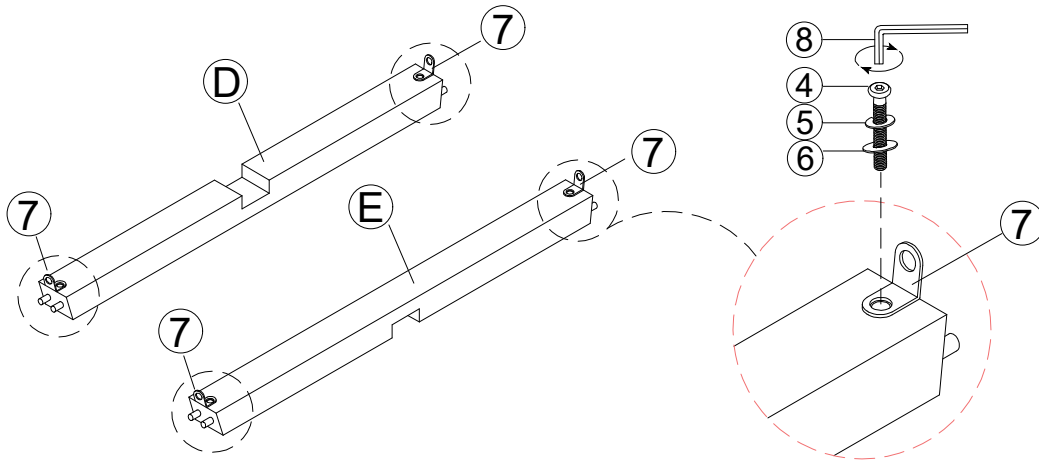
ITEM: WF318593 / WF318594

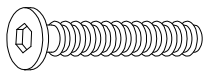





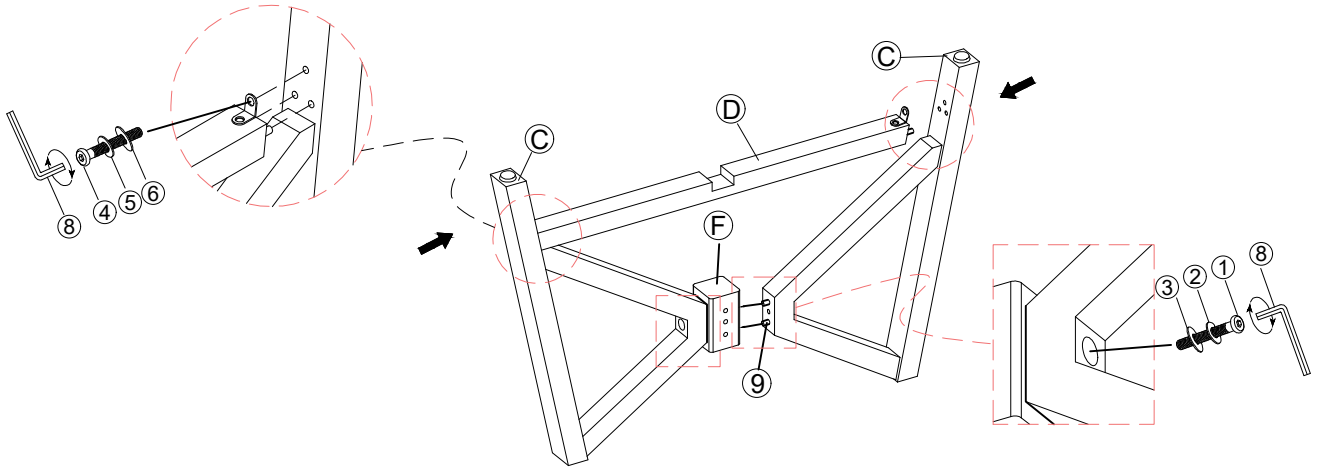

STEP 1

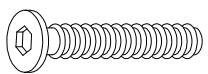

4  Ø1/4"x20mm	BOLT (4PCS)	5  Ø1/4"x11mm	SPRING WASHER (4PCS)
6  Ø1/4"x19mm	FLAT WASHER (4PCS)	7 	L METAL BRACKET (4PCS)
8  M4	ALLEN KEY (1PC)		

STEP 2









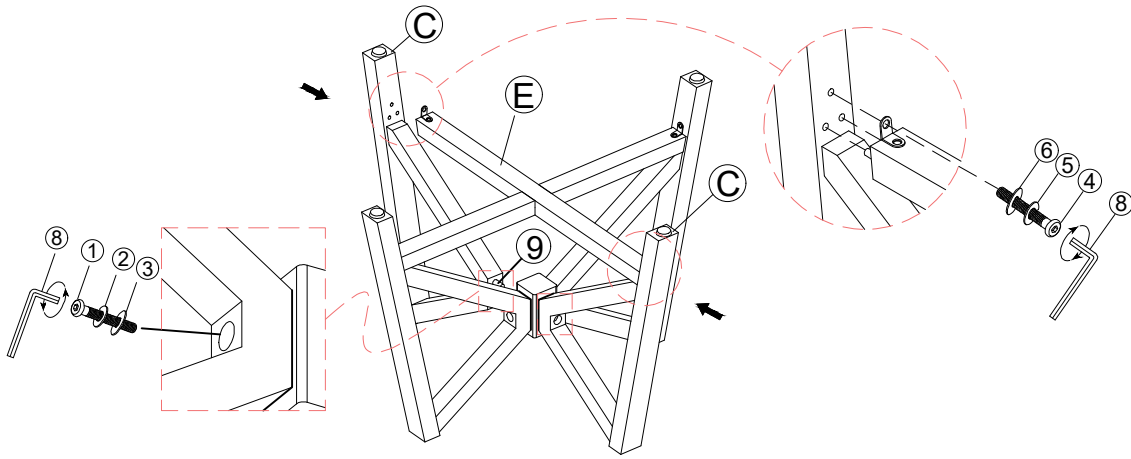

1  Ø5/16"x38mm	BOLT (2PCS)	2  Ø5/16"x13mm	SPRING WASHER (2PCS)
3  Ø5/16"x19mm	FLAT WASHER (2PCS)	4  Ø1/4"x20mm	BOLT (2PCS)
5  Ø1/4"x11mm	SPRING WASHER (2PCS)	6  Ø1/4"x19mm	FLAT WASHER (2PCS)
8  M4	ALLEN KEY (1PC)	9 	WOOD DOWEL (4PCS)

ASSEMBLY INSTRUCTION

ITEM: WF318593 / WF318594

STEP 3



1  Ø5/16"x38mm	BOLT (2PCS)	2  Ø5/16"x13mm	SPRING WASHER (2PCS)
3  Ø5/16"x19mm	FLAT WASHER (2PCS)	4  Ø1/4"x20mm	BOLT (2PCS)
5  Ø1/4"x11mm	SPRING WASHER (2PCS)	6  Ø1/4"x19mm	FLAT WASHER (2PCS)
8  M4	ALLEN KEY (1PC)	9 	WOOD DOWEL (4PCS)

STEP 4

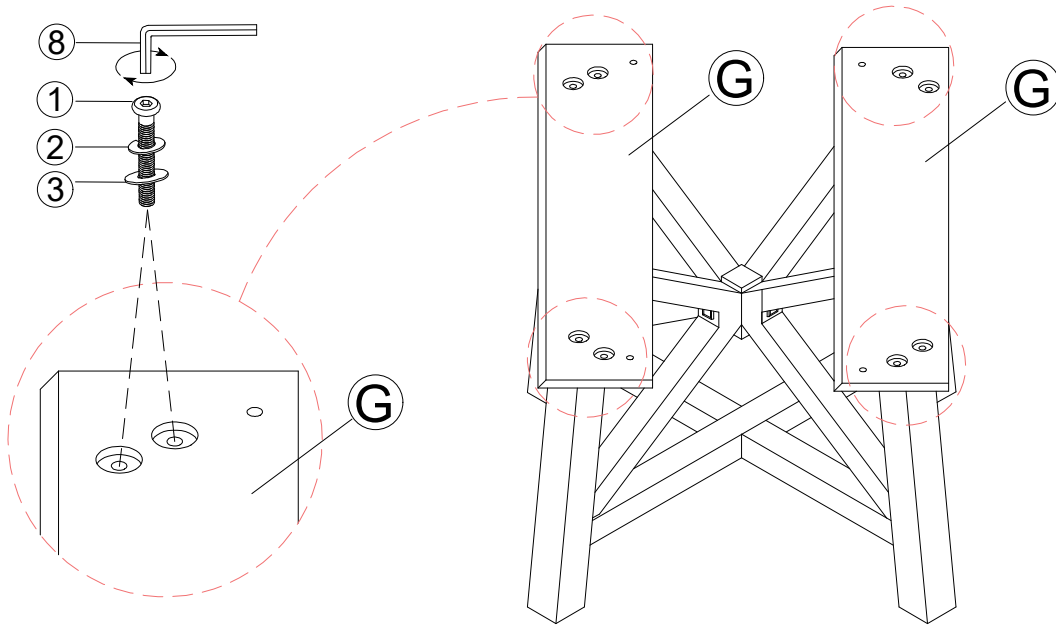

1  Ø5/16"x38mm	BOLT (8PCS)	2  Ø5/16"x13mm	SPRING WASHER (8PCS)
3  Ø5/16"x19mm	FLAT WASHER (8PCS)	8  M4	ALLEN KEY (1PC)

ASSEMBLY INSTRUCTION

ITEM: WF318593 / WF318594

STEP 5

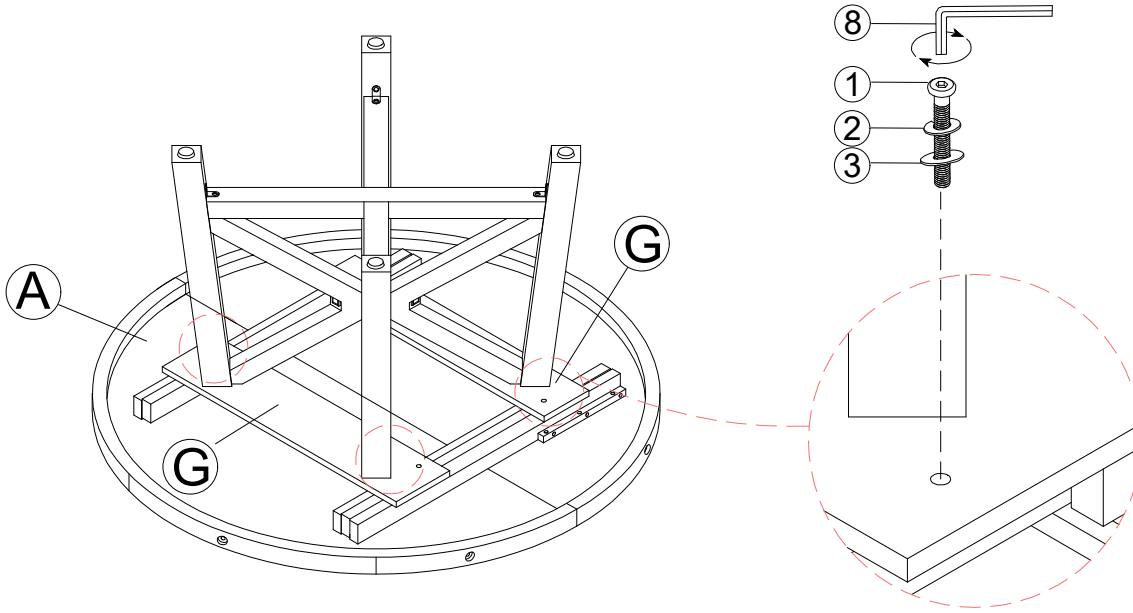

1  Ø5/16"x38mm	BOLT (4PCS)	2  Ø5/16"x13mm	SPRING WASHER (4PCS)
3  Ø5/16"x19mm	FLAT WASHER (4PCS)	8  M4	ALLEN KEY (1PC)

STEP 6

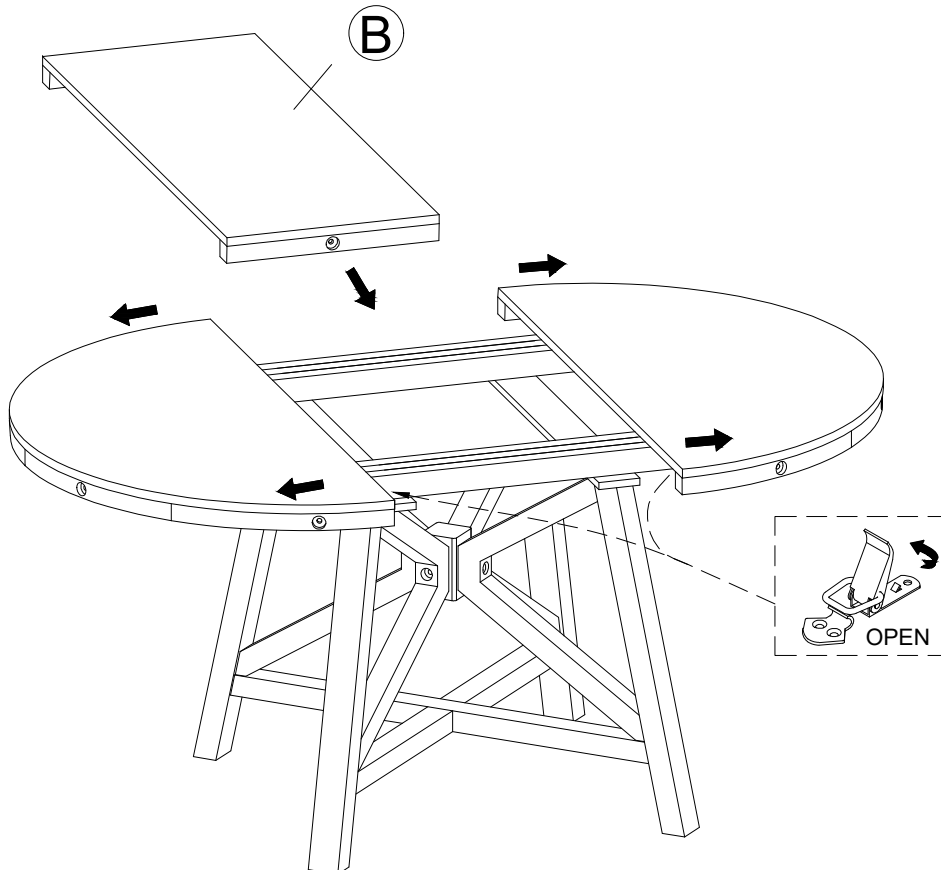

ASSEMBLY INSTRUCTION
ITEM: WF318593 / WF318594

COMPLETE

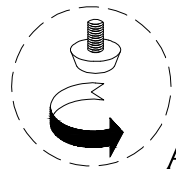
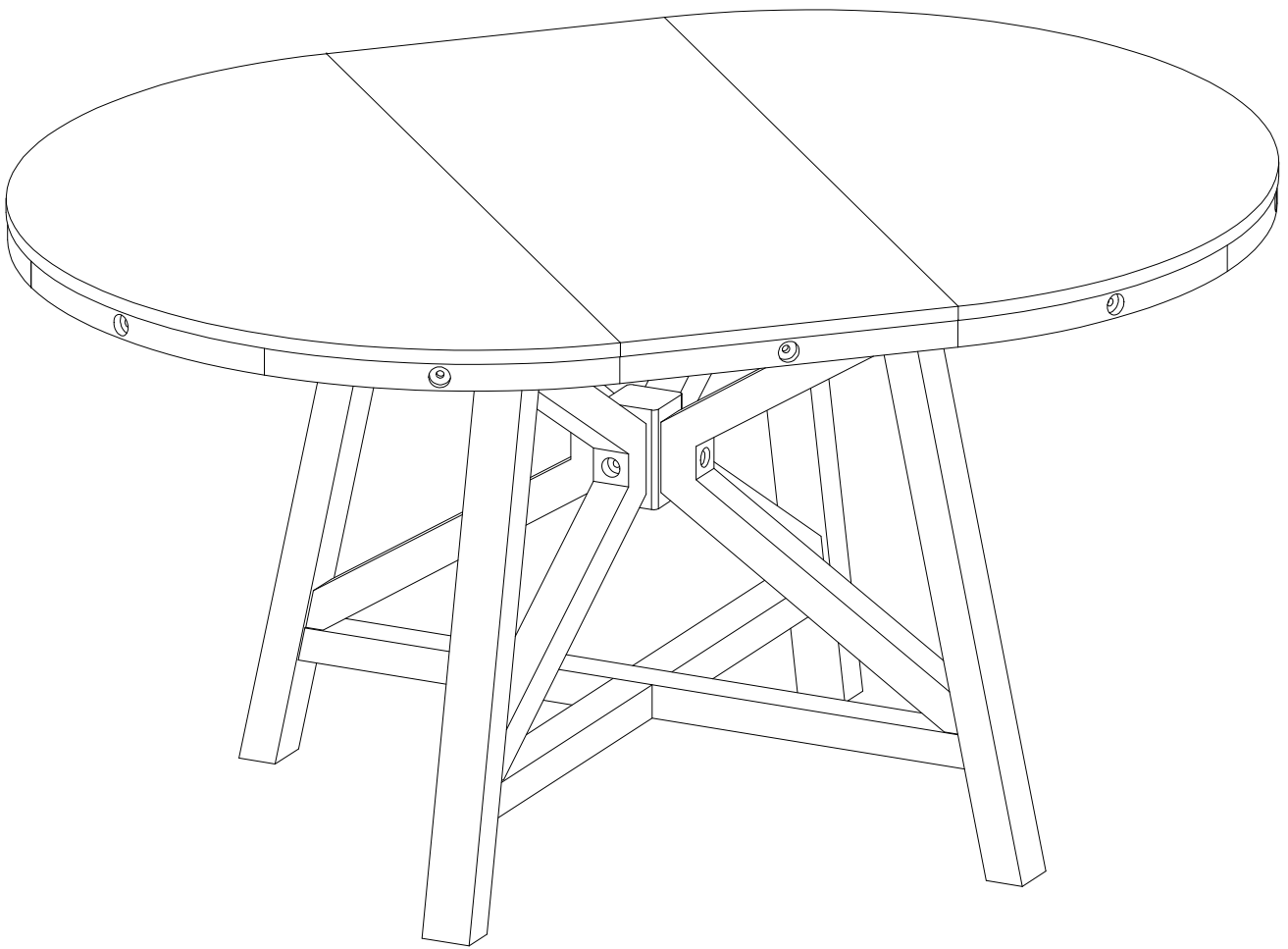

Adjust Leveler=4pcs.