

ASSEMBLY INSTRUCTION
ITEM:WF317096
SIDEBOARD

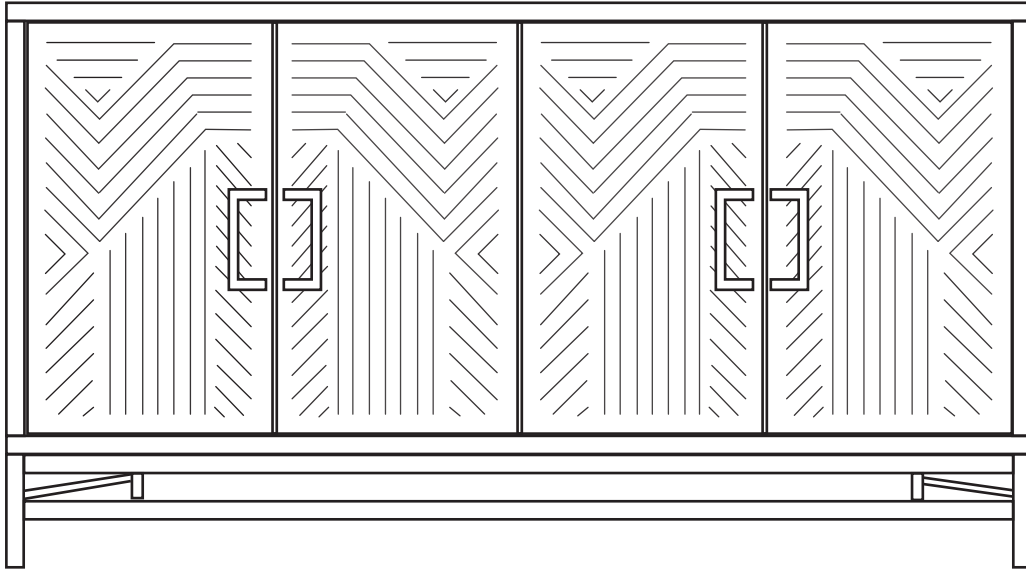

ASSEMBLY INSTRUCTION

ITEM:WF317096

Please read these instructions fully before starting assembly :

Tools required: Phillips screwdriver(medium & large)

- 1.Check you have all the components and tools listed on the following pages.
- 2.Remove all fittings from the plastic bags and separate them into their groups.
- 3.Keep children and animals away from the work area, small parts could choke if swallowed.
- 4.Make sure you have enough space to layout the parts before starting.
- 5.During assembly do not stand or put weight on the product, this could cause damage.
- 6.Assemble the item as close to its final position (in the same room) as possible.
- 7.Assemble on a soft level surface to avoid damaging the unit or your floor.
- 8.Parts of the assembly will be easier with 2 people.
- 9.To reduce the likelihood of damaging your product please ensure that your power drill is set on a low torque setting.
- 10.Assemble all parts and bolts loosely during assembly, only once the product is complete should you fully tighten the bolts.
- 11.Regularly check and ensure That all bolts and fittings are tightend properly.
- 12.Please do not place items that exceed the load capacity.

Care and maintenance

Only clean using a damp cloth and mild detergent, do no use bleach or abrasive cleaners.

ASSEMBLY INSTRUCTION

ITEM:WF317096

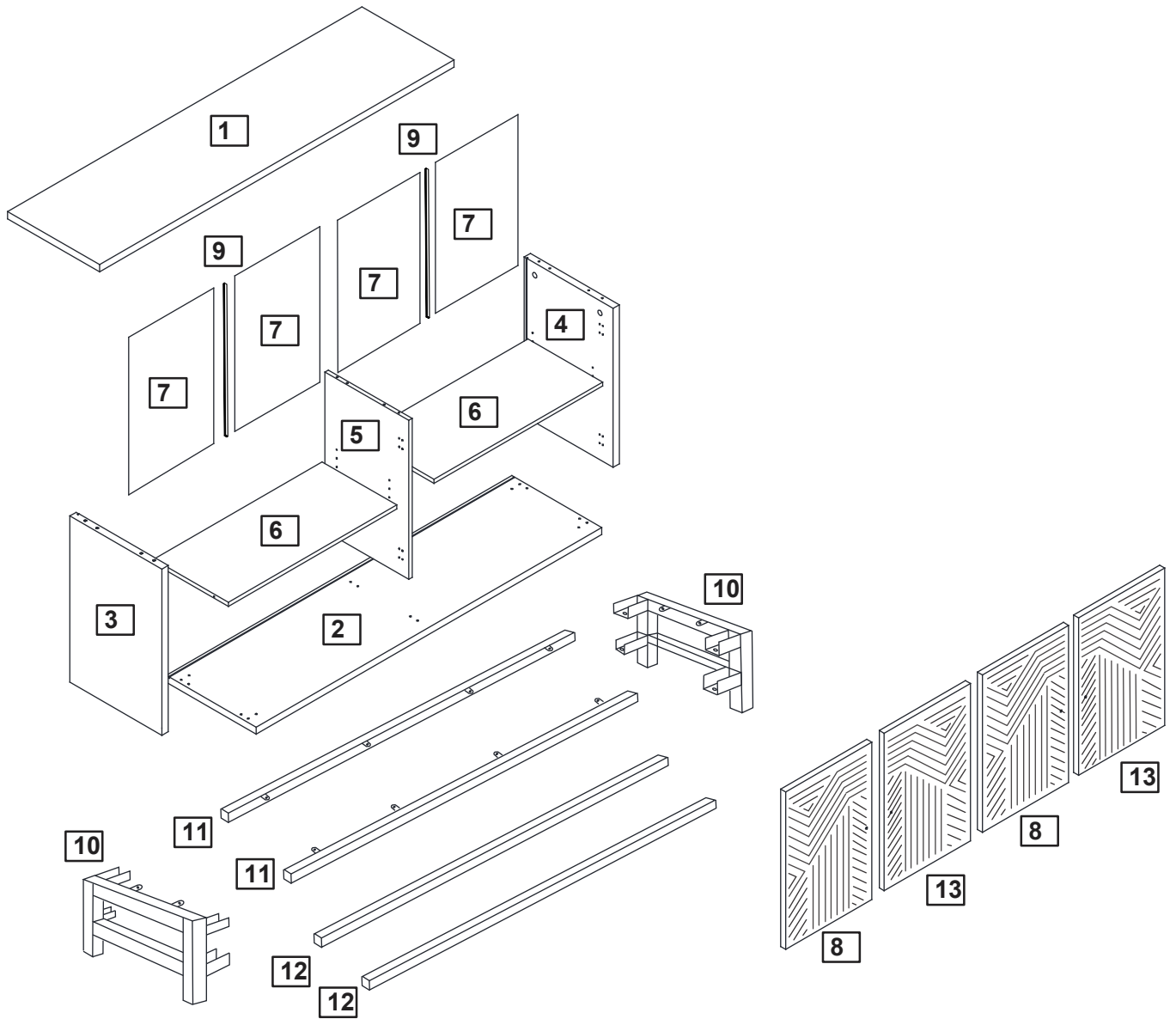





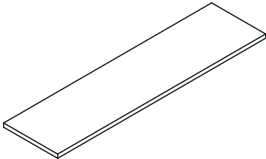
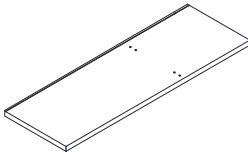
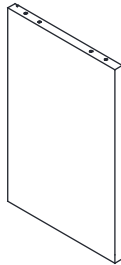
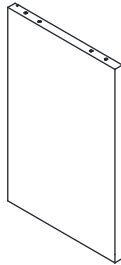
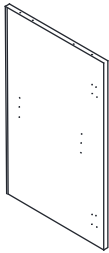
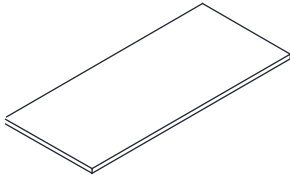

Part List

ITEM:WF317096

Please check you have all the panels listed below

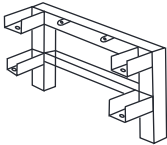
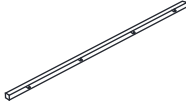
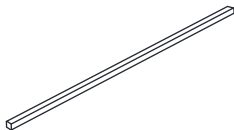
Note: The quantities below are the correct amount to complete the assembly. In some cases more fittings may be supplied than are required.











<p>①</p>  <p>Top Panel 1 PC</p>	<p>②</p>  <p>Bottom Panel 1 PC</p>	<p>③</p>  <p>Left Panel 1 PC</p>	<p>④</p>  <p>Right Panel 1 PC</p>
<p>⑤</p>  <p>Medial panel 1 PC</p>	<p>⑥</p>  <p>Center Shelf 2PCS</p>	<p>⑦</p>  <p>Center Shelf 4 PCS</p>	<p>⑧</p>  <p>Left Door 2PCS</p>
<p>⑨</p>  <p>Rear panel 2 PCS</p>	<p>⑩</p>  <p>Foot part 2 PCS</p>	<p>⑪</p>  <p>Foot part 2PCS</p>	<p>⑫</p>  <p>Foot part 2PCS</p>
<p>⑬</p>  <p>Right Door 2 PCS</p>			

Hardware list

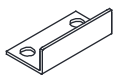
ITEM:WF317096

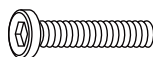
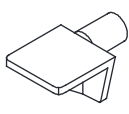
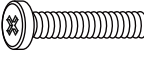
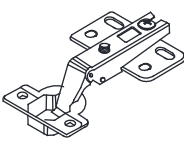
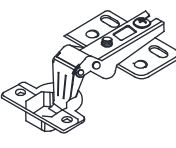
Please check you have all the panels listed below

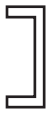
Note: The quantities below are the correct amount to complete the assembly. In some cases more fittings may be supplied than are required.

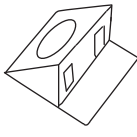

<p>A</p>  <p>Male Camlock x 6</p>	<p>B</p>  <p>Female Camlock x 6</p>	<p>C</p>  <p>Dowel x 12</p>	<p>D</p>  <p>5*60mm Screw x 6</p>
<p>E</p>  <p>E x 1</p>	<p>F</p>  <p>collision x 2</p>	<p>G</p>  <p>3*14mm Screw x 12</p>	<p>H</p>  <p>8*15mm Screw x 4</p>
<p>I</p>  <p>Shelf Support Pin x 8</p>	<p>J</p>  <p>6*12mm Screw x 8</p>	<p>K</p>  <p>Door Hinge x 4</p>	<p>L</p>  <p>Door Hinge x 4</p>
<p>M</p>  <p>4*16mm Screw x 56</p>	<p>N</p>  <p>Handle x 4</p>	<p>O</p>  <p>6*28mm Screw x 8</p>	<p>P</p>  <p>Plastic wedge x 8</p>

Hardware list

ITEM:WF317096

Please check you have all the panels listed below

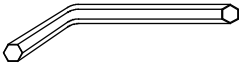
Note: The quantities below are the correct amount to complete the assembly. In some cases more fittings may be supplied than are required.

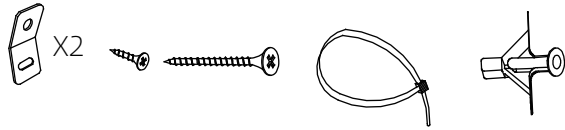
<p>Q</p>  <p>Qx 1</p>	<p>R</p>  <p>Rx 4</p>	<p>S</p>  <p>S₁ S₂ S₃ S₄ S₅</p> <p>Wall Fixing Pack x 1</p>
---	---	---

ASSEMBLY INSTRUCTION

ITEM:WF317096

Step 1

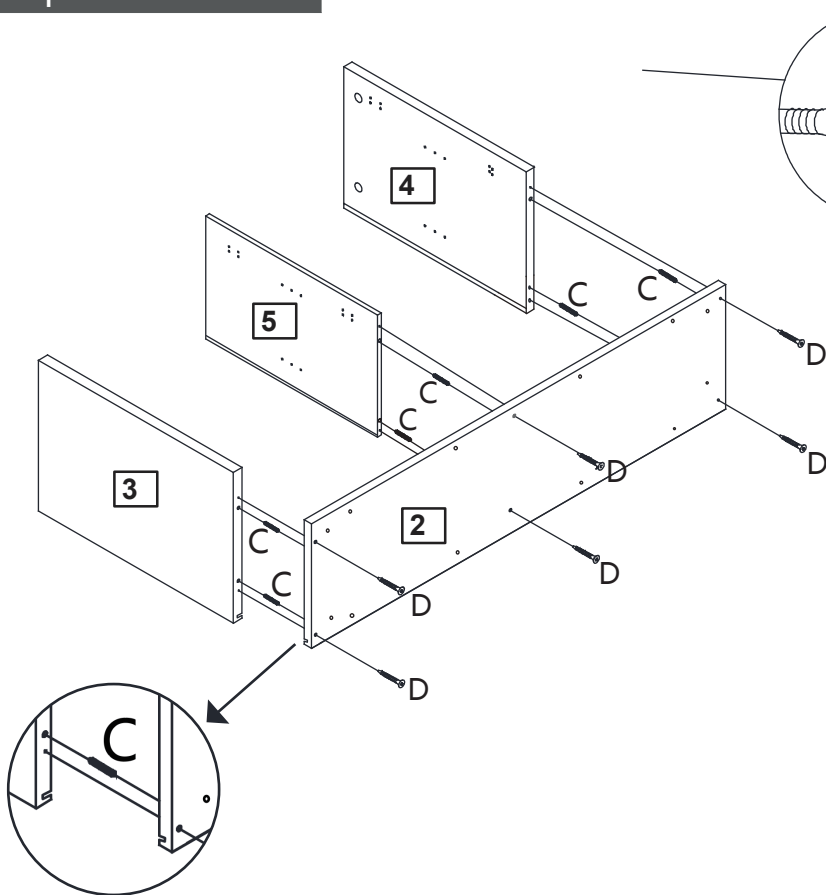

Step 2

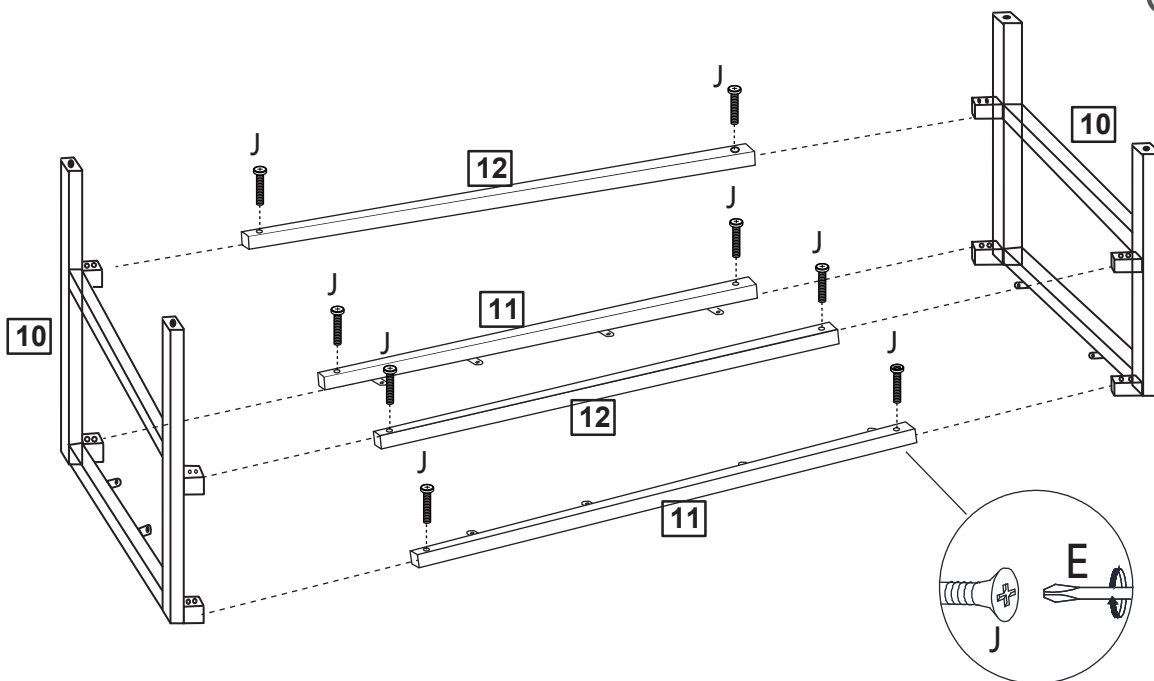

ASSEMBLY INSTRUCTION

ITEM:WF317096

Step 3

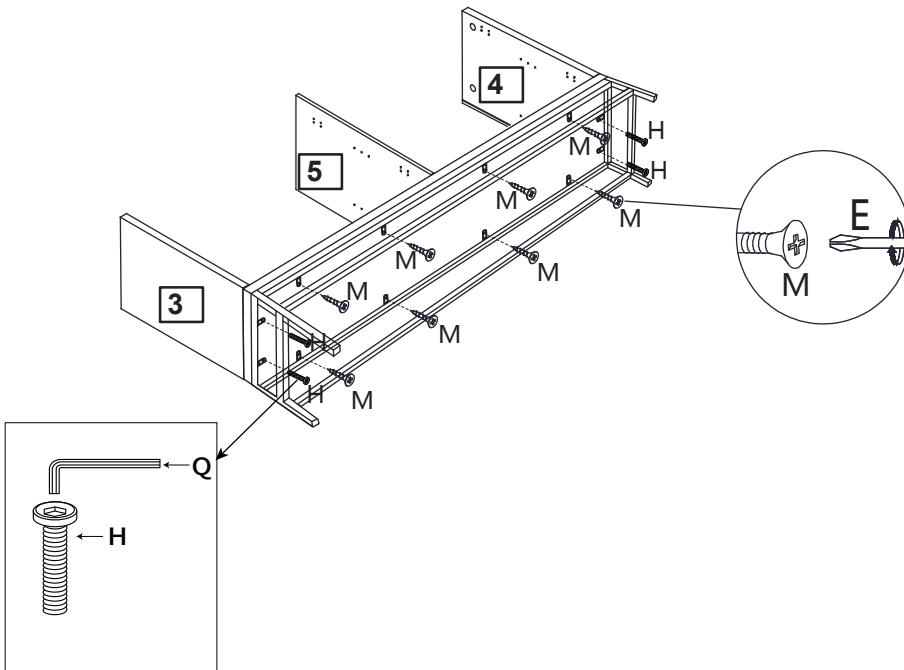

H x 4



M x 8



Q x 1

Step 4

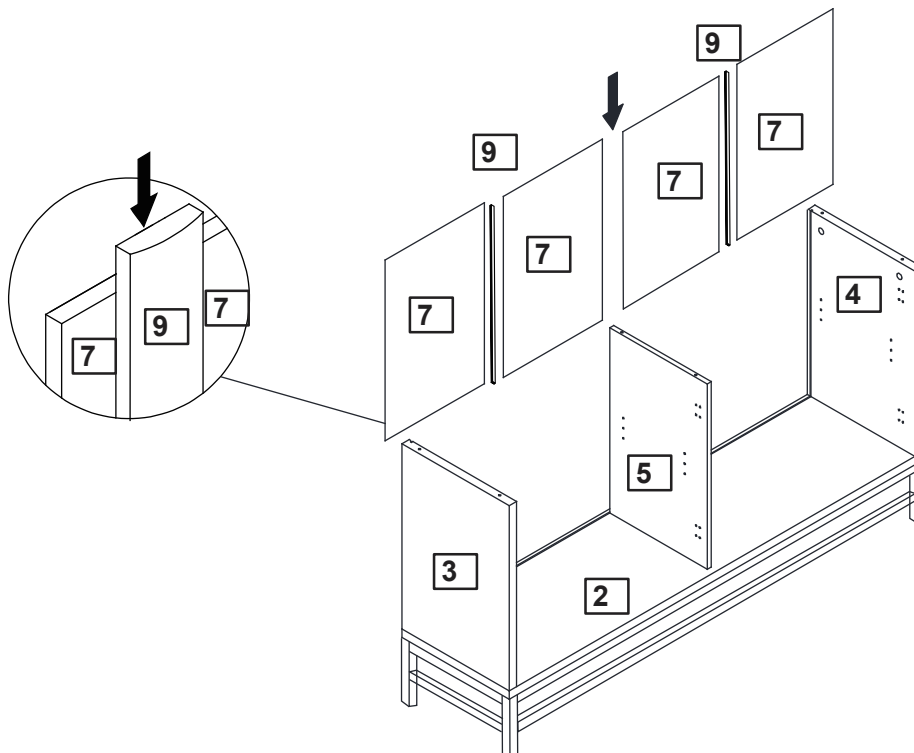

ASSEMBLY INSTRUCTION

ITEM:WF317096

Step 5

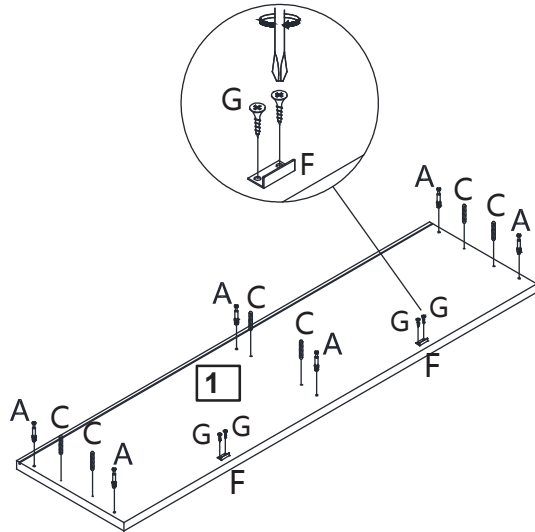

A x 6



C x 6



G x 4

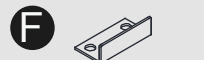

F x 2

Step 6

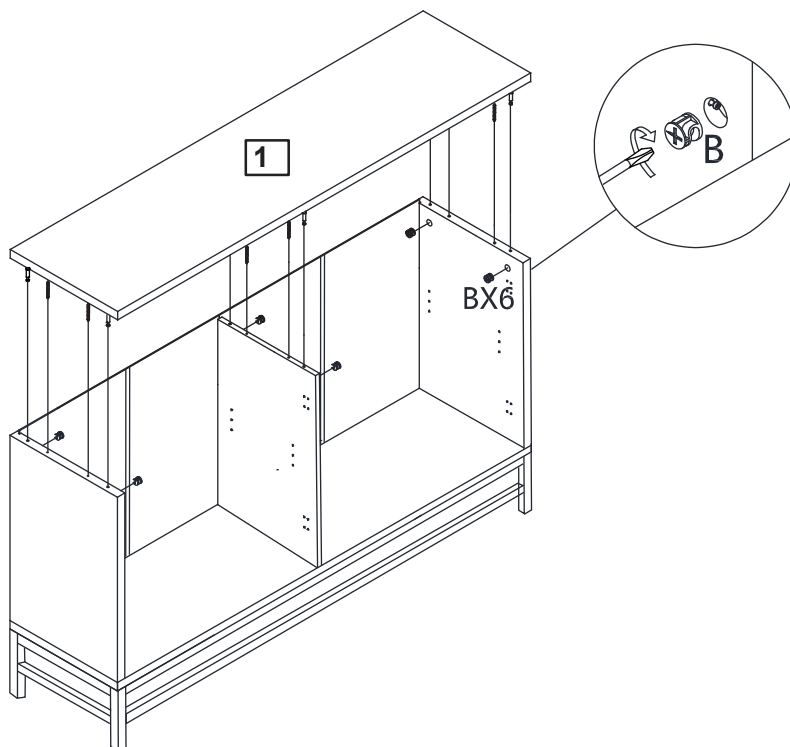

B x 6

ASSEMBLY INSTRUCTION

ITEM:WF317096

Step 7

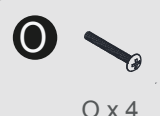
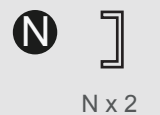
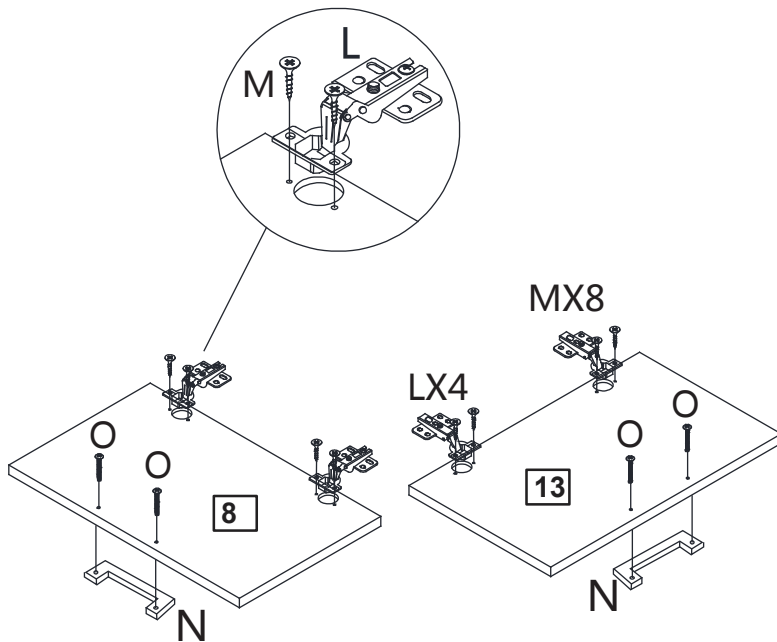

Step 8

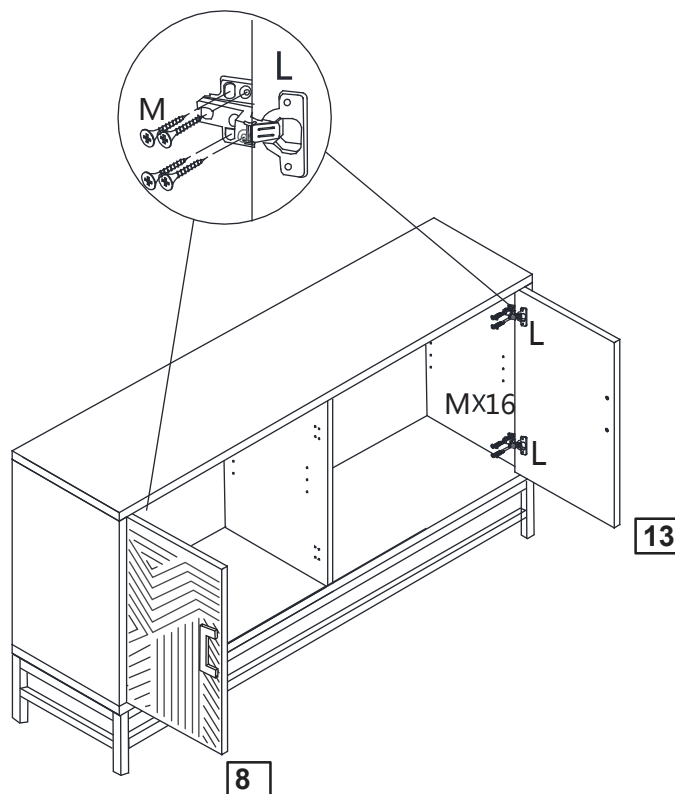

ASSEMBLY INSTRUCTION

ITEM:WF317096

Step 9

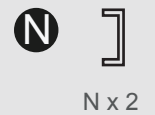
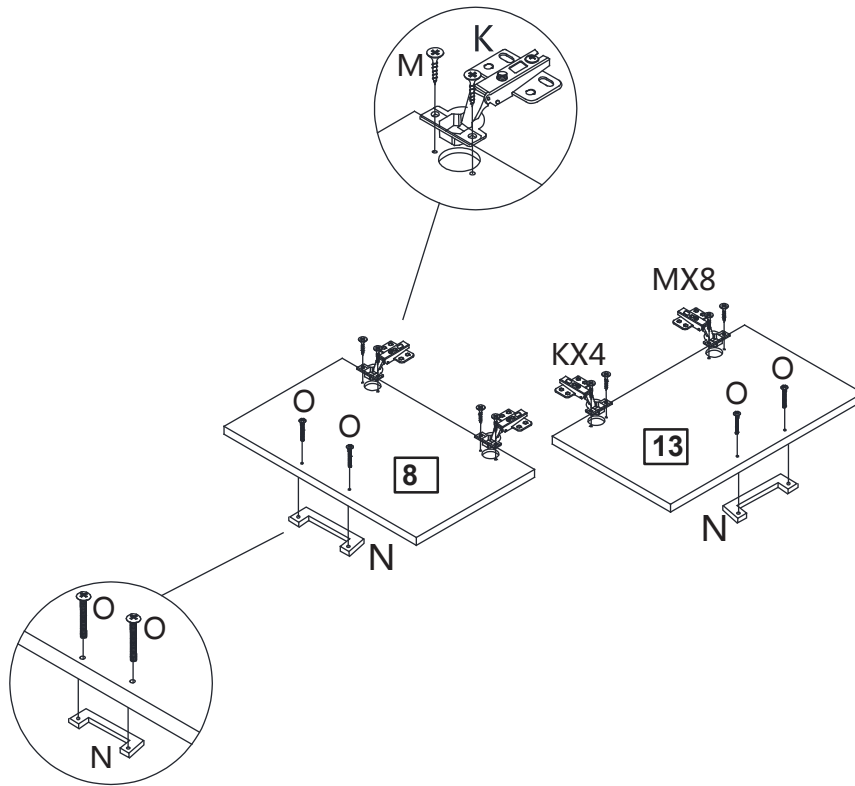

Step 10

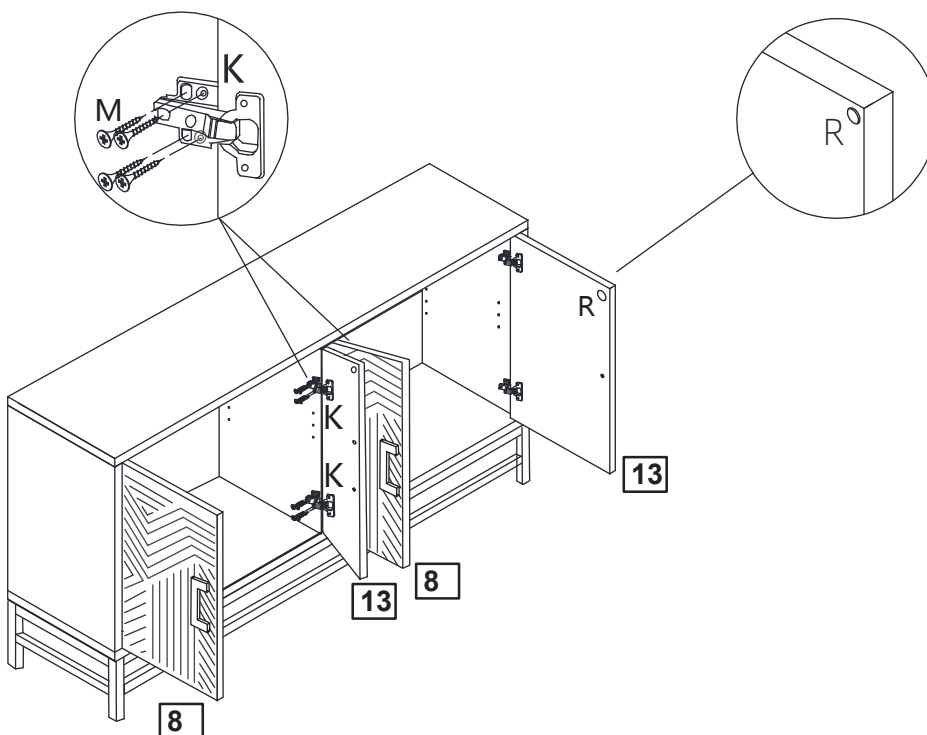

ASSEMBLY INSTRUCTION

ITEM:WF317096

Step 11

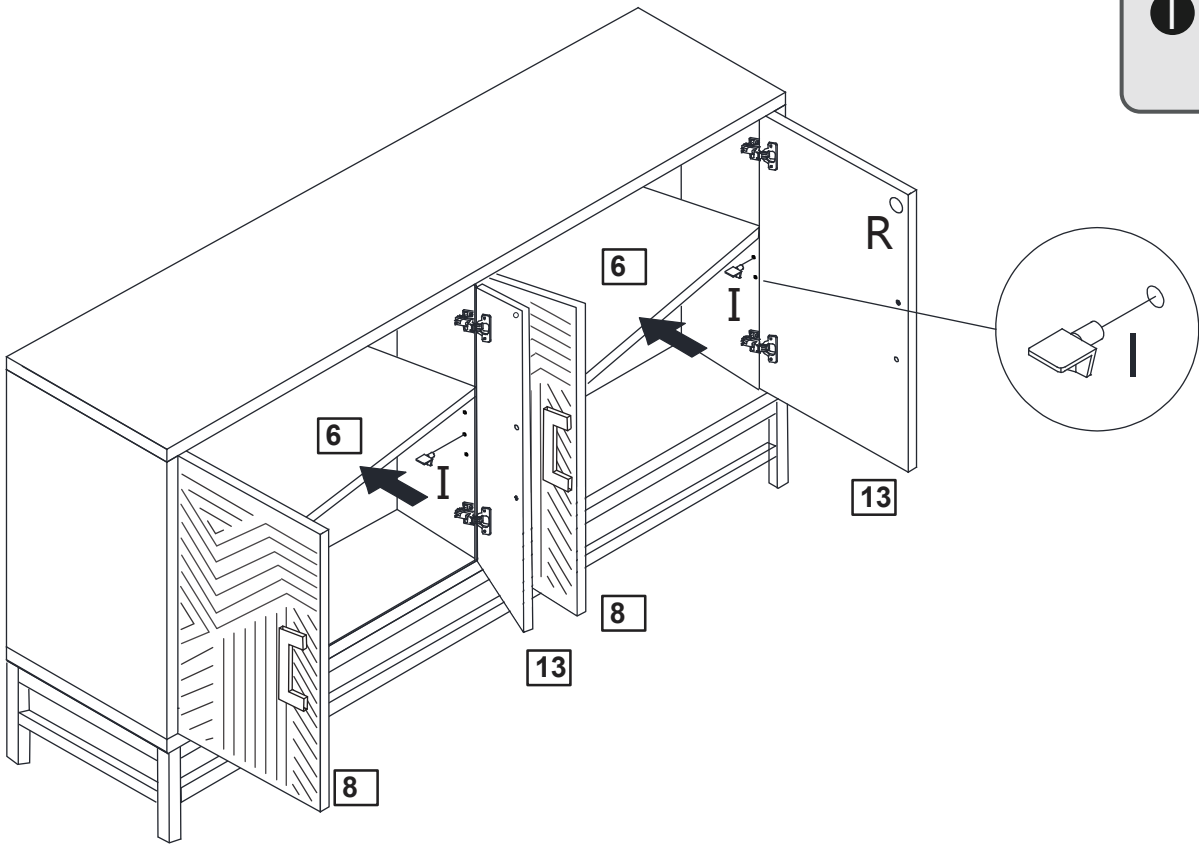

Step 10

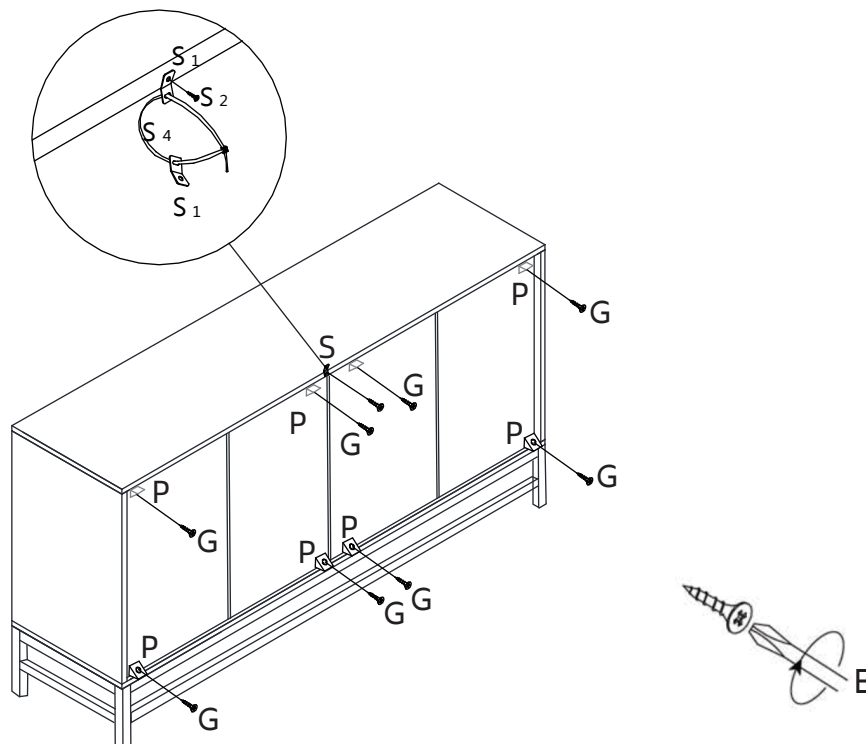

ASSEMBLY INSTRUCTION

ITEM:WF317096

Step 11

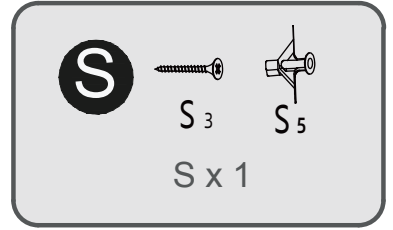
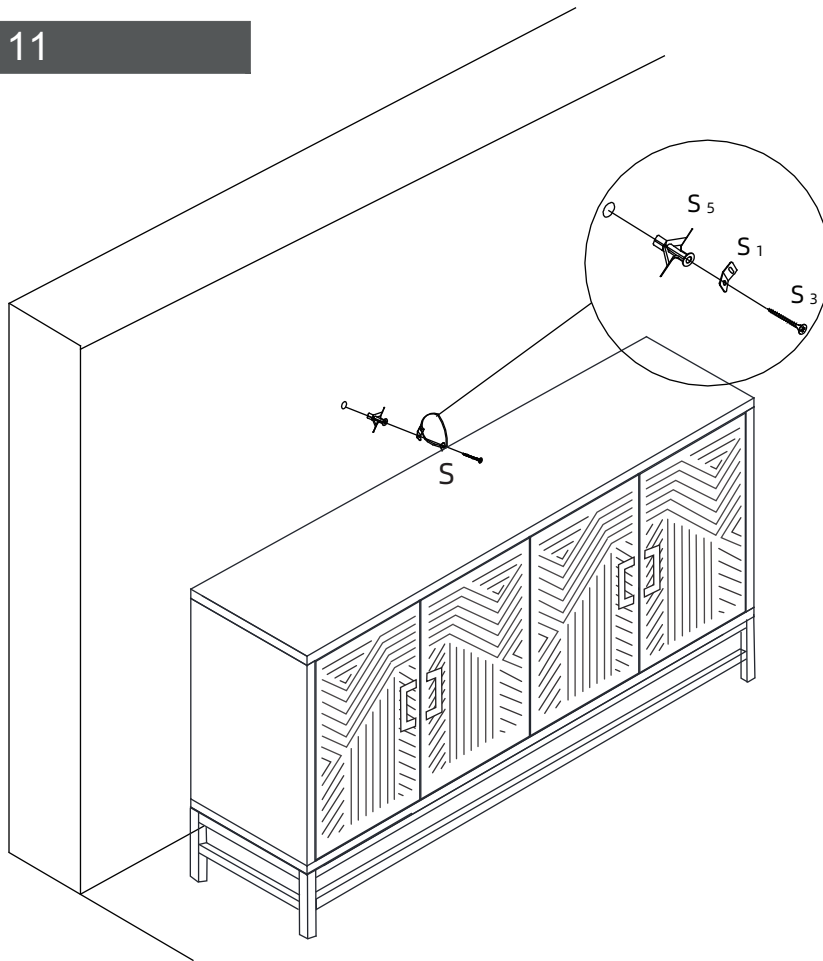

Assembly is complete.

Assembly Steps(EN) / Montageschritte(DE)

HOW TO ADJUST THE HINGES TO ALIGN THE DOORS IF NEEDED.

STEP 1

Open the door.

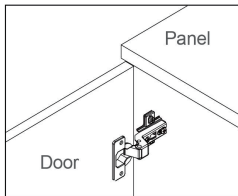

STEP 3

Adjust the flush between door panel and side panel

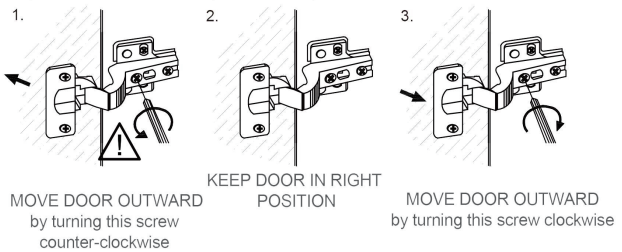

STEP 2

Adjust the door panels up or down

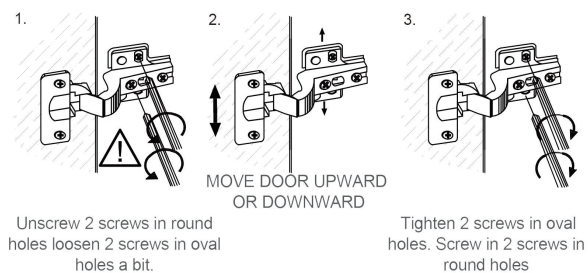

STEP 4

Adjust the Gap between door panel and side panel

