

ASSEMBLY INSTRUCTIONS

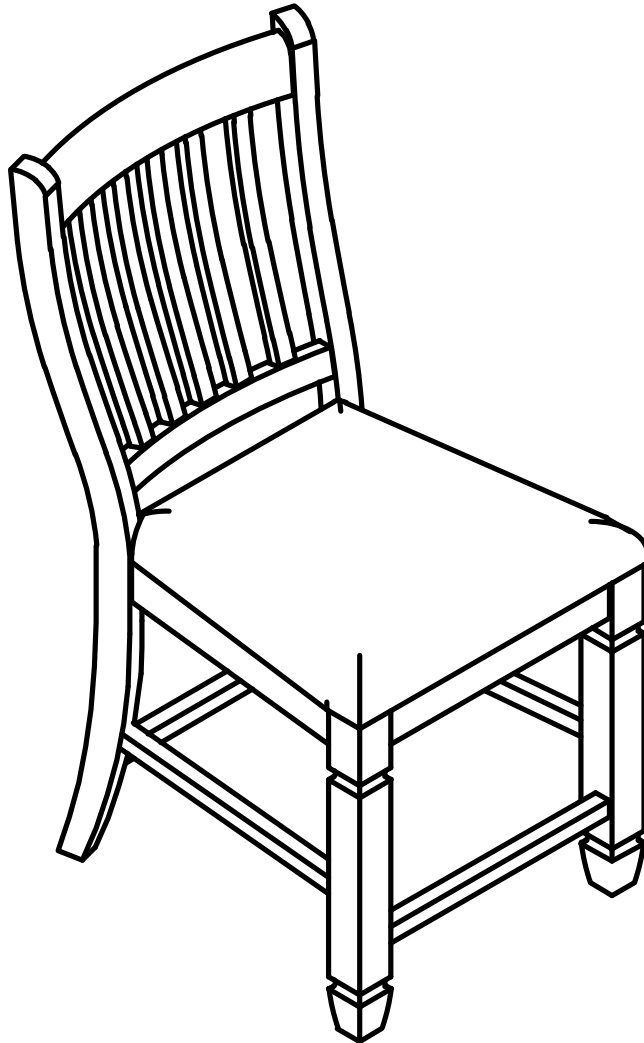

WF316877AAD
WF316877AAE

PRE ASSEMBLY INTRODUCTION

We understand building ready-to-assemble furniture can be a challenging experience for some. To help avoid confusion, we have provided some helpful tips that may speed up the process.

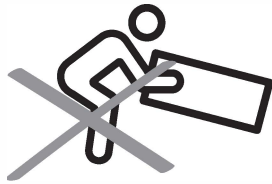

Teamwork

ALWAYS have at least two people to help with transporting and assembling the product to avoid potential injury and/or damage.

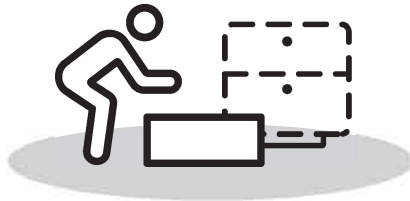
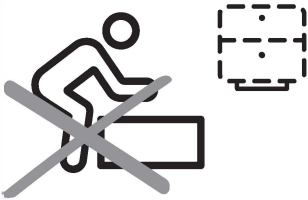

Suitable Location

Assembling near the area of the intended location is highly recommended.



Sufficient Space

Make sure you have enough space to move around during the assembly.

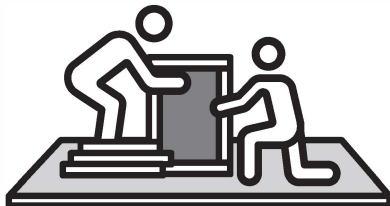

Avoid Scratches

Use cardboard, blankets or a carpeted area while assembling furniture to prevent scratches.

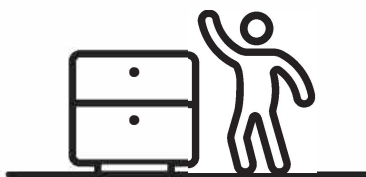
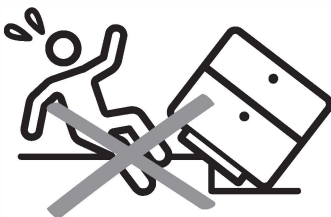

Flat Surface

Make sure the furniture rests on a flat and level surface with each leg evenly touching the floor.

PARTS

#A 1pc

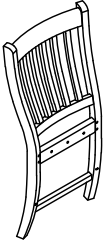

Back chair

#B 1pc

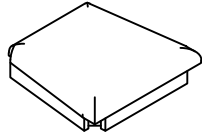

Seat cushion

#C 1pc

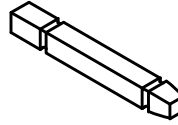

Left front leg

#D 1pc

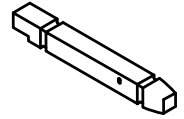

Right front leg

#E 1pc

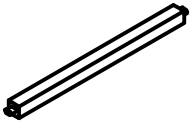

Front stretcher

#F 1pc

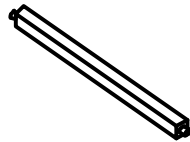

Left side stretcher

#G 1pc



Right side stretcher

HARDWARE

#1

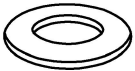

Flat Washer $\text{\O}1/4"$ x 10pcs

#2



Lock Washer $\text{\O}1/4"$ x 10pcs

#3



Bolt $\text{\O}1/4"$ x 1-1/2" x 2pcs

#4



Bolt $\text{\O}1/4"$ x 2-1/8" x 4pcs

#5



Bolt $\text{\O}1/4"$ x 3" x 4pcs

#6

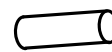

Wooden dowel $\text{\O}8$ x 1-2/8" x 1pc

#7

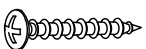

Screw $\text{\O}8$ x 1-1/2" x 6pcs

#8

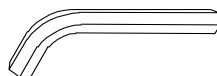

Allen Key 4mm x 1pc

ASSEMBLY INSTRUCTIONS

Step 1

Attach Wooden dowel (#6) and Seat cushion (#B) on the Back chair (#A) by using Flat washer (#1), Lock washer (#2), Bolt (#3) with Allen key (#8).

- Part (#A) 1pc
- Part (#B) 1pc
- Hardware (#1) 2pcs
- Hardware (#2) 2pcs
- Hardware (#3) 2pcs
- Hardware (#6) 1pc

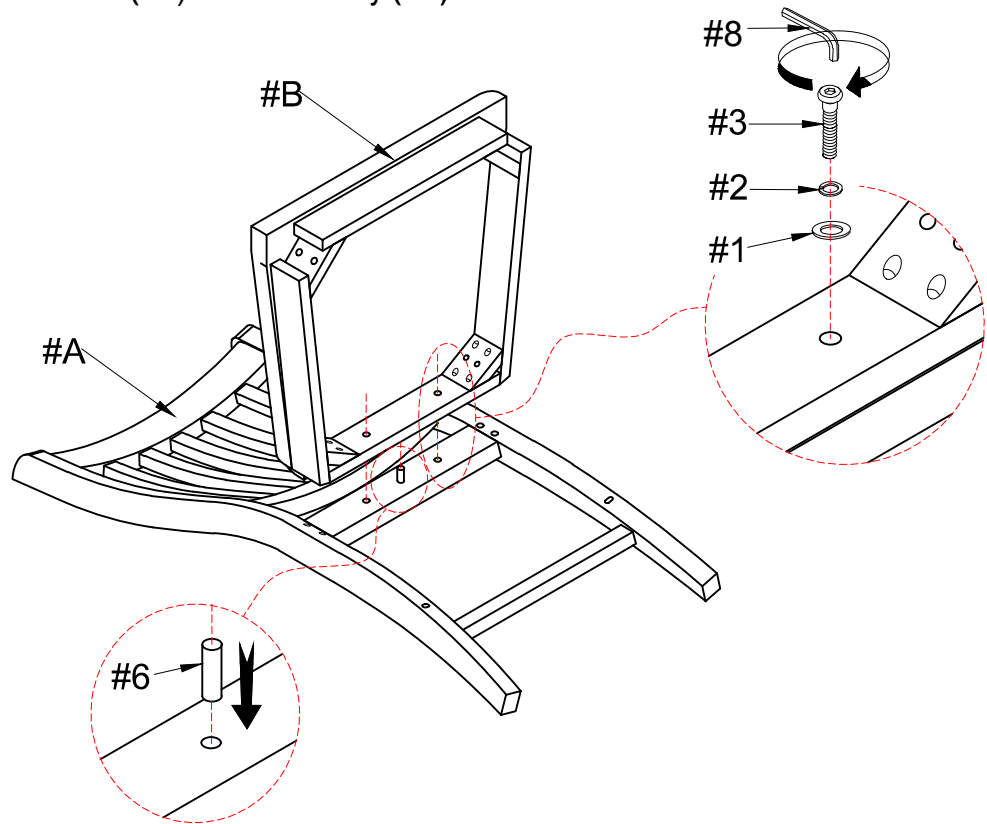

Step 2

Then connect Seat cushion (#B) to the Back chair (#A) by using Flat washer (#1), Lock washer (#2), Bolt (#5) with Allen key (#8).

- Part (#A) 1pc
- Part (#B) 1pc
- Hardware (#1) 4pcs
- Hardware (#2) 4pcs
- Hardware (#5) 4pcs

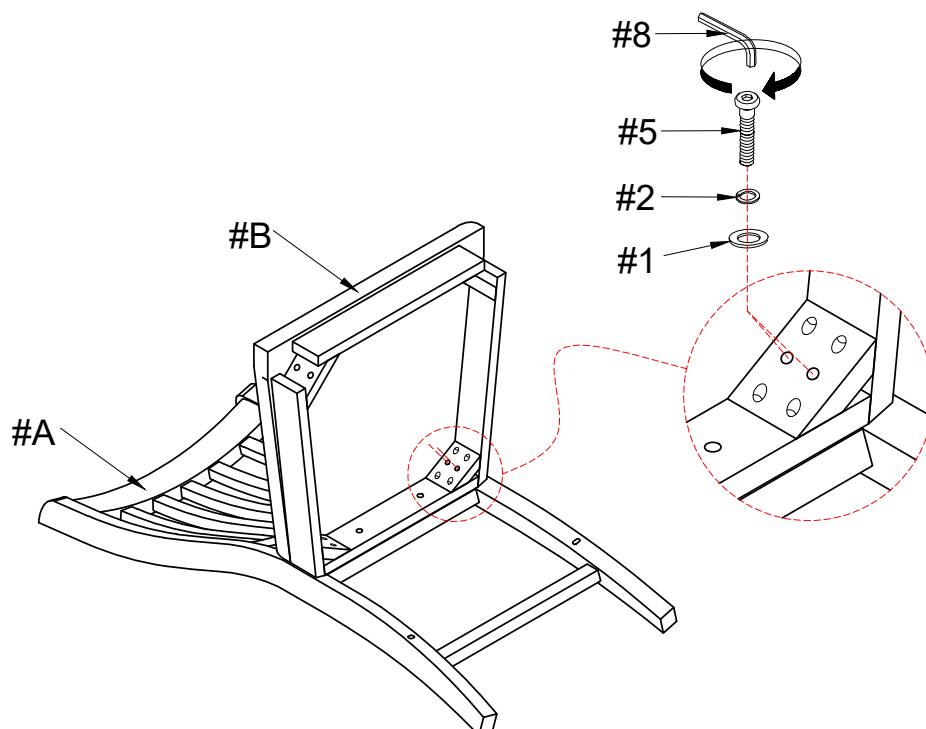

ASSEMBLY INSTRUCTIONS

Step 3

Attach Left side stretcher (#F) and Right side stretcher (#G) on the Back chair (#A).

Part #F 1pc

Part #G 1pc

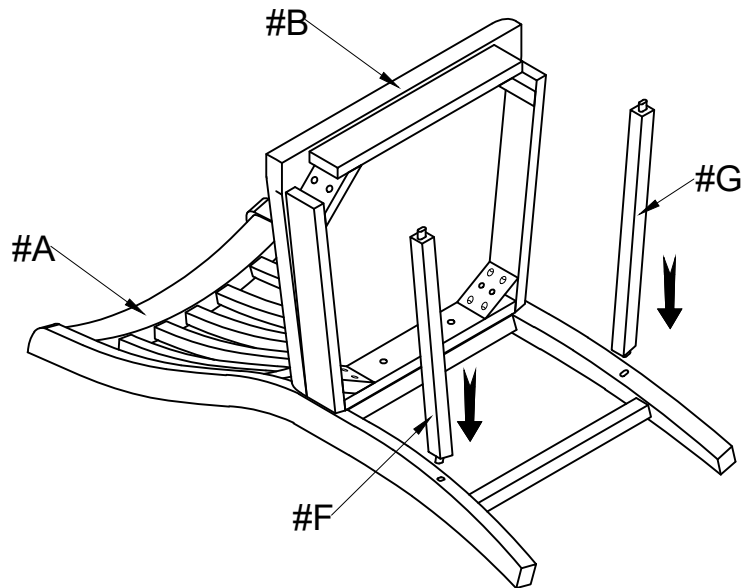

Step 4

Attach Left front leg (#C), Right front leg (#D) and Front stretcher (#E) on the Chair of step 3 by using Flat washer (#1), Lock washer (#2), Bolt (#4) with Allen key (#8).

Part #C 1pc

Part #D 1pc

Part #E 1pc

Hardware #1 4pcs

Hardware #2 4pcs

Hardware #4 4pcs

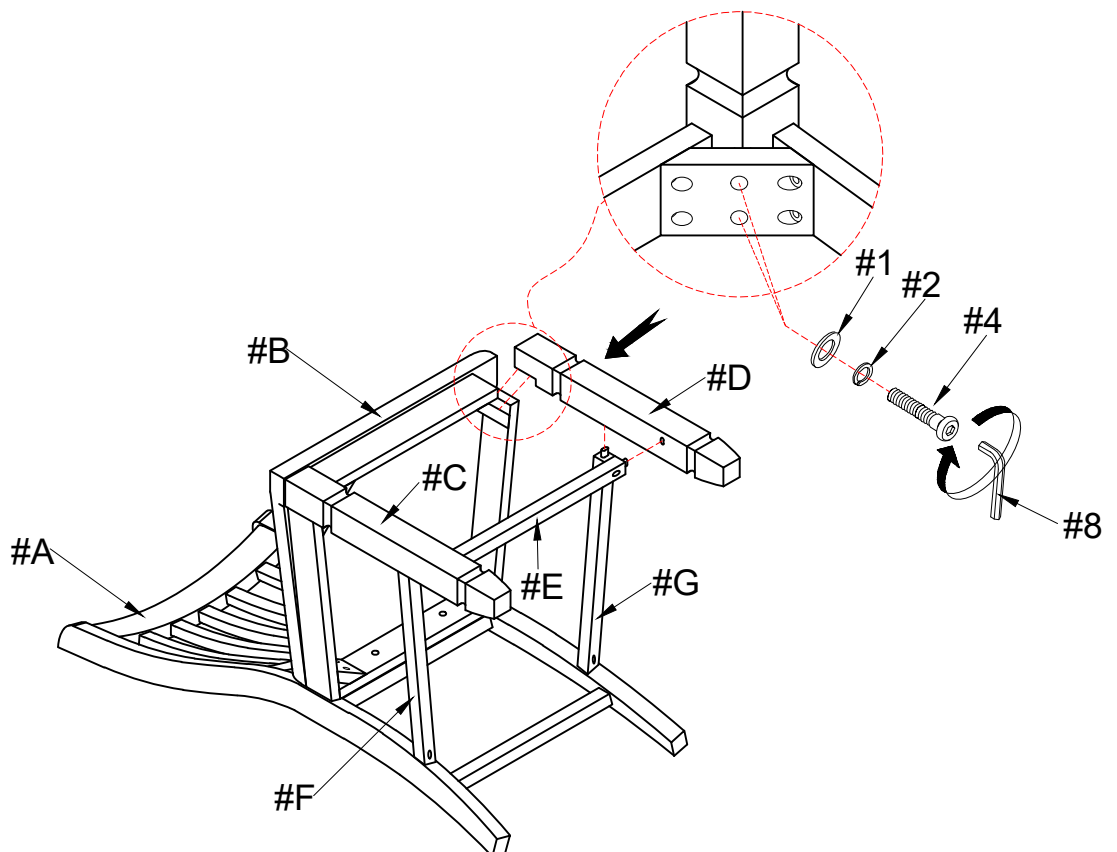

ASSEMBLY INSTRUCTIONS

Step 5

Then using Screw (#7) to connect Left side stretcher (#F), Right side stretcher (#G) and Front stretcher (#E) with Chair.

Hardware (#7) 6pcs

