

ASSEMBLY INSTRUCTIONS

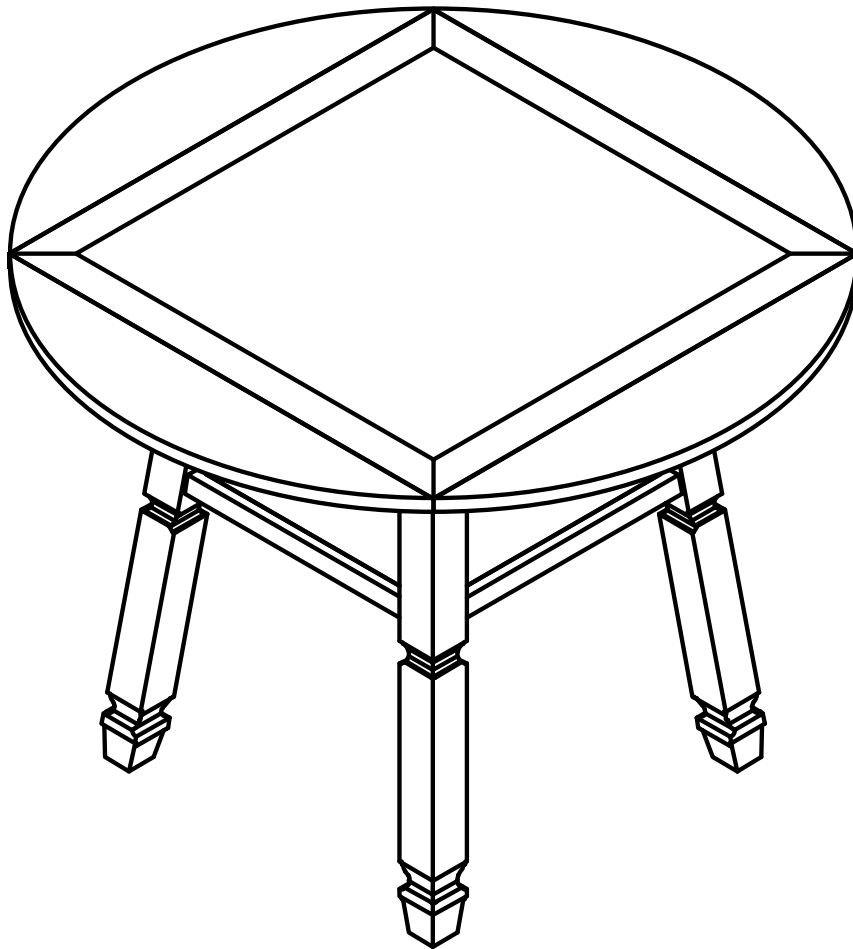

WF316876AAD
WF316876AAE

PRE ASSEMBLY INTRODUCTION

We understand building ready-to-assemble furniture can be a challenging experience for some. To help avoid confusion, we have provided some helpful tips that may speed up the process.

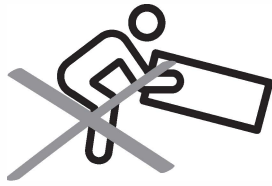

Teamwork

ALWAYS have at least two people to help with transporting and assembling the product to avoid potential injury and/or damage.

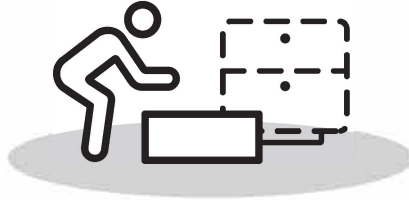
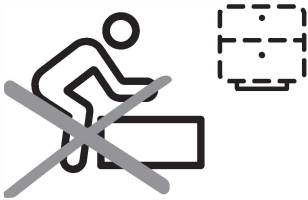

Suitable Location

Assembling near the area of the intended location is highly recommended.



Sufficient Space

Make sure you have enough space to move around during the assembly.



Avoid Scratches

Use cardboard, blankets or a carpeted area while assembling furniture to prevent scratches.

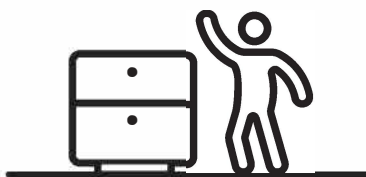
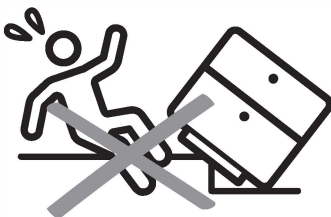

Flat Surface

Make sure the furniture rests on a flat and level surface with each leg evenly touching the floor.

PARTS

#A 1pc

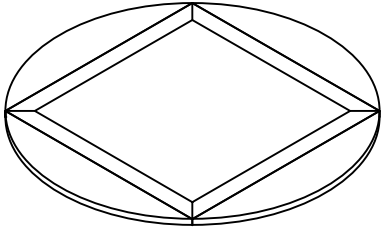
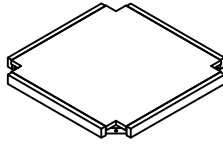

Table top

#B 1pc



Shelf

#C 4pcs

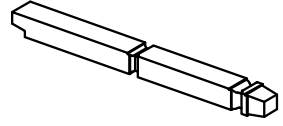

Legs

HARDWARE

#1

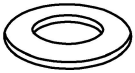

Flat Washer $\text{Ø}5/16''$ x 8pcs

#2



Lock Washer $\text{Ø}5/16''$ x 8pcs

#3



Bolt $\text{Ø}5/16''$ x 2-1/8'' x 8pcs

#4



Allen Key 4mm x 1pc

ASSEMBLY INSTRUCTIONS

Step 1

Attach Legs (#C) on the Table top (#A) by using Flat washer (#1), Lock washer (#2), Bolt (#3) with Allen key (#4).

Part (#A) 1pc

Part (#C) 4pcs

Hardware (#1) 4pcs

Hardware (#2) 4pcs

Hardware (#3) 4pcs

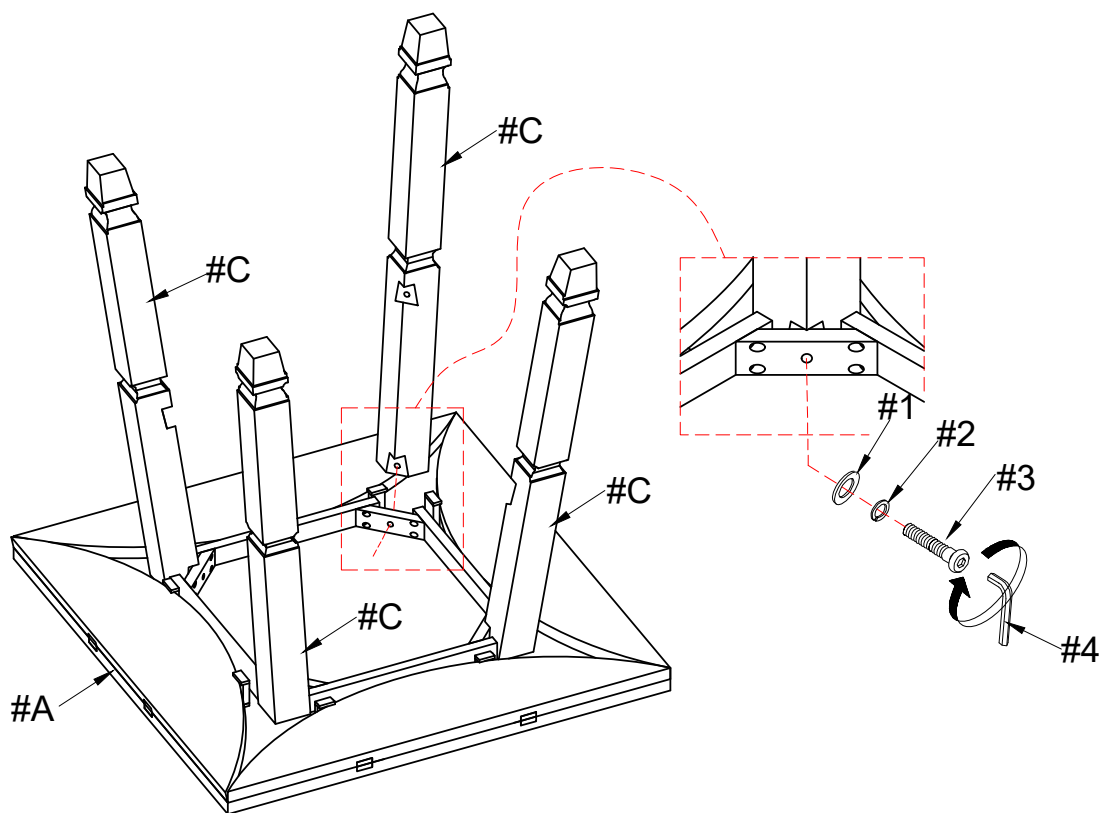

Step 2

Then connect Shelf (#B) to the Table top (#A) by using Flat washer (#1), Lock washer (#2), Bolt (#3) with Allen key (#4).

Part (#B) 1pc

Hardware (#1) 4pcs

Hardware (#2) 4pcs

Hardware (#3) 4pcs

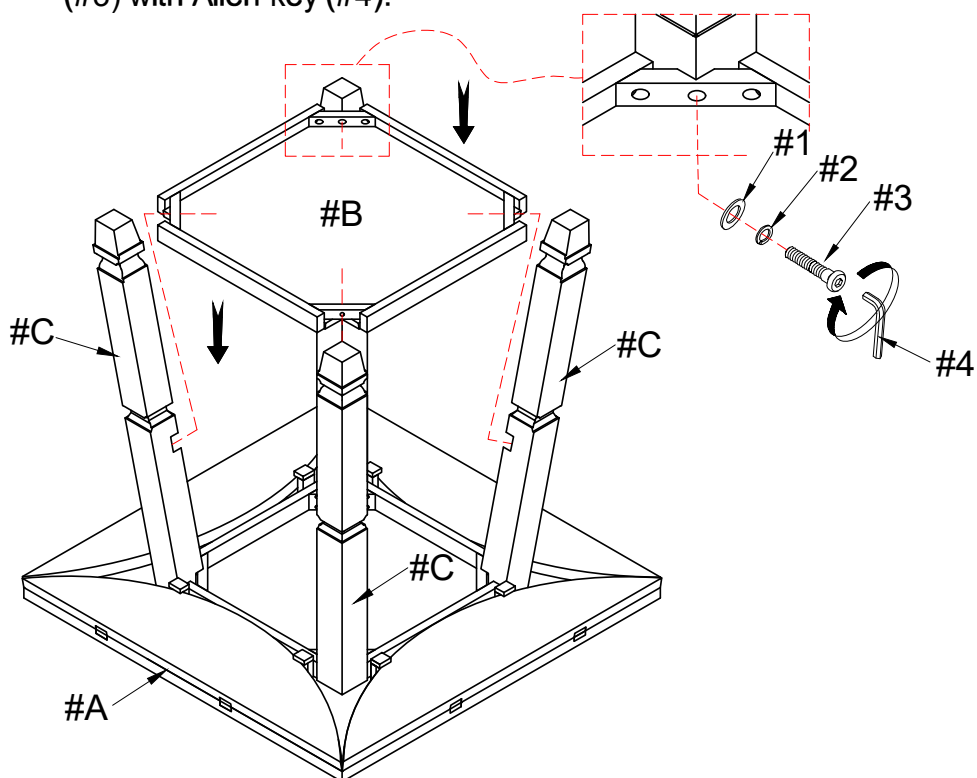

ASSEMBLY INSTRUCTIONS

Step 3

Open the table top to get a complete table.

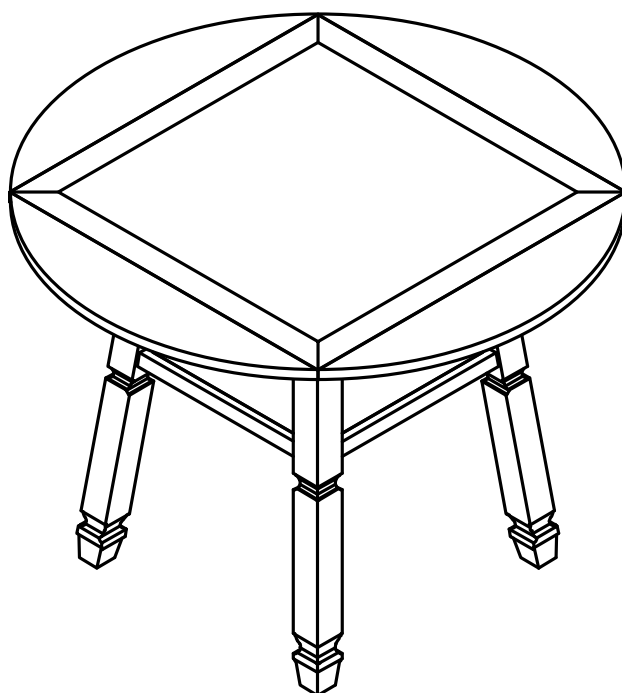
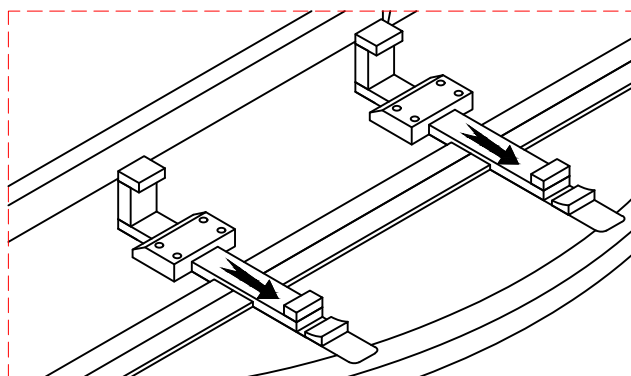
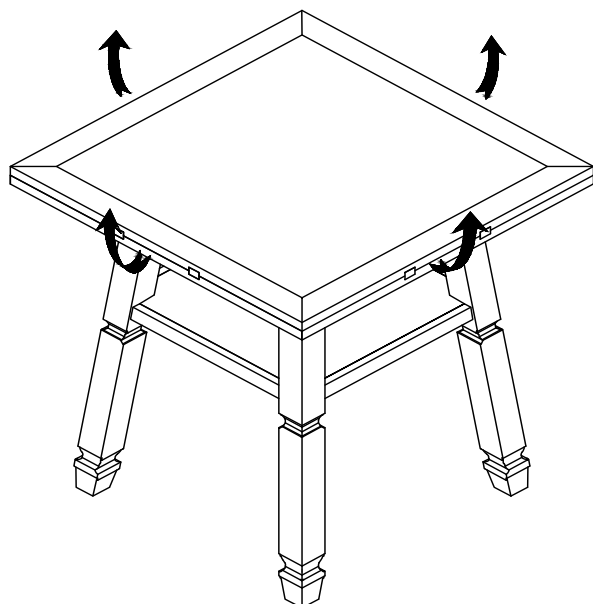

MADE IN VIETNAM