

# ASSEMBLY INSTRUCTIONS

## WF 311953 DINING CHAIR

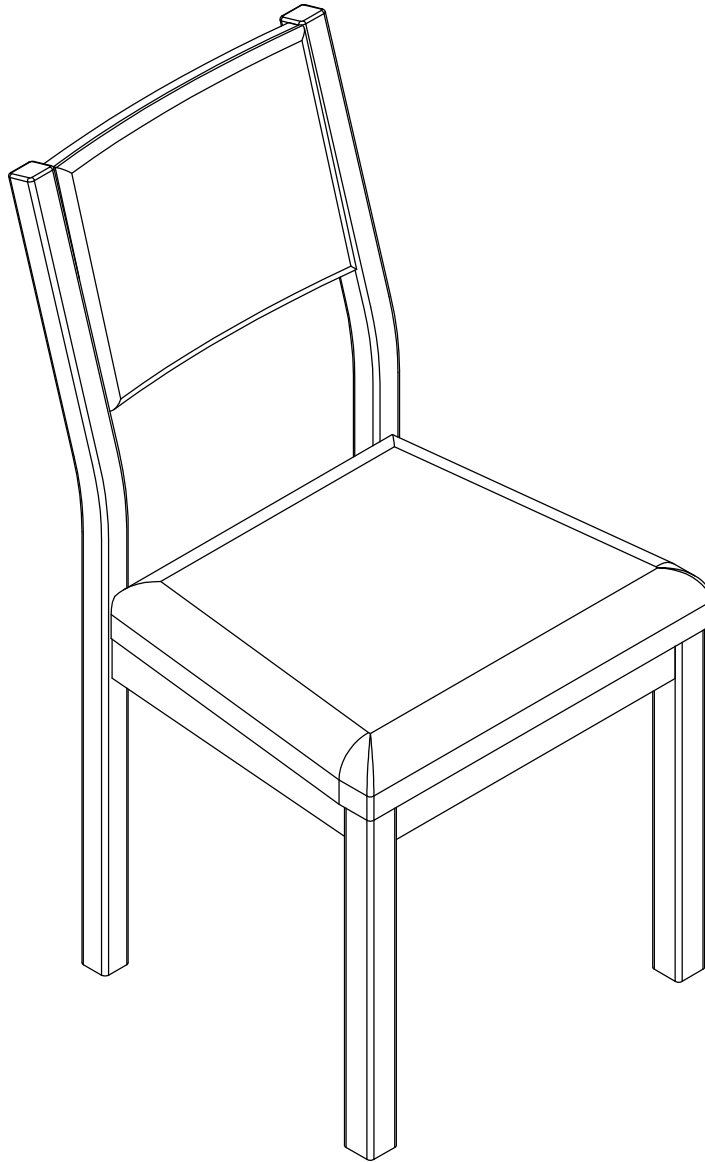





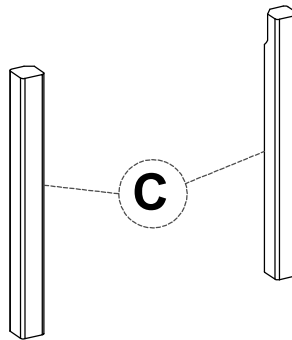
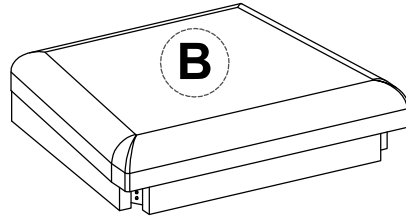
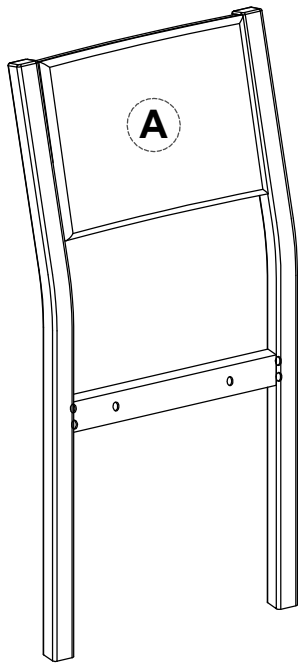

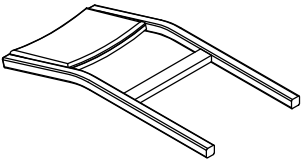

### IMPORTANT NOTE:

- ① PLACE ALL PARTS ON A CLEAN AND SMOOTH SURFACE SUCH AS A RUG OR CARPET TO AVOID THE PARTS FROM BEING SCRATCHED.
- ② BEFORE YOU BEGIN, KINDLY FOLLOW THE ASSEMBLY INSTRUCTIONS STEP BY STEP.
- ③ DO NOT TIGHEN ALL SCREWS AND BOLTS UNTIL THE CHAIR IS FULLY STEP-UP

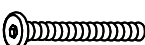

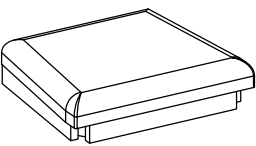



**Part List For One**

**Hardware List For One**

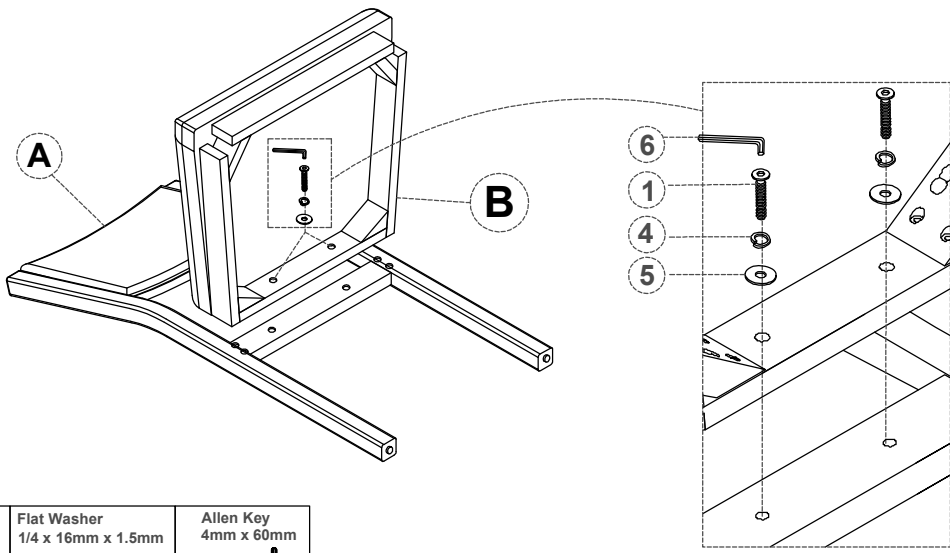
No	Parts Desc.	Q'ty	No	Hardware Desc.	Q'ty
A	BACK FRAME 	1pcs	1	Bolts 1/4"* 35mm 	2pcs
			2	Bolts 1/4"* 70mm 	4pcs
			3	Bolts 1/4"* 50mm 	4pcs
B	SEAT FRAME 	1pcs	4	Spring Washer 1/4"* 13mm x 1.5mm 	10pcs
			5	Flat Washer 1/4"* 16mm x 1.5mm 	10pcs
			6	Allen Key 4mm*60mm 	1pcs
C	FRONT LEGS 	2pcs			





**STEP 1**

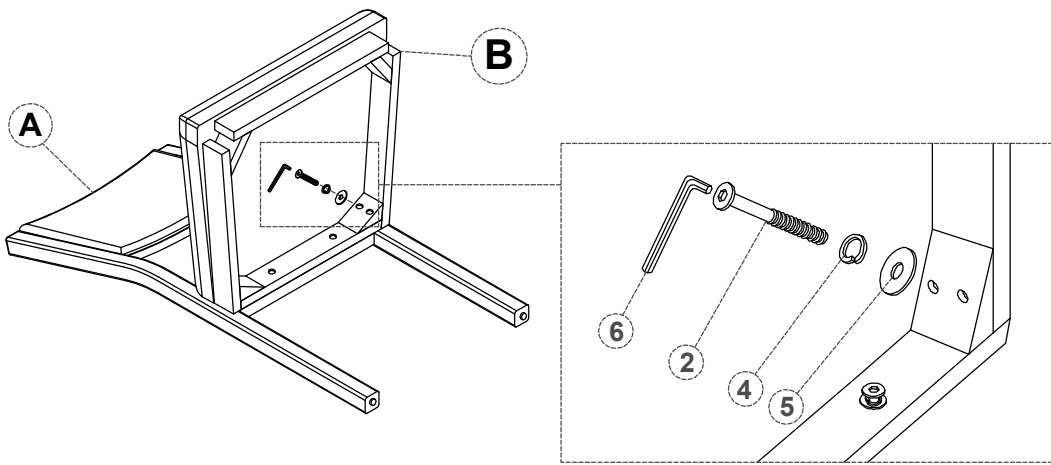

<b>Bolts</b> 1/4 x 35mm  ① x 2	<b>Spring Washer</b> 1/4 x 11mm x 1.5mm  ④ x 2	<b>Flat Washer</b> 1/4 x 16mm x 1.5mm  ⑤ x 2	<b>Allen Key</b> 4mm x 60mm  ⑥ x 1
---	--	--	--





**STEP 2**

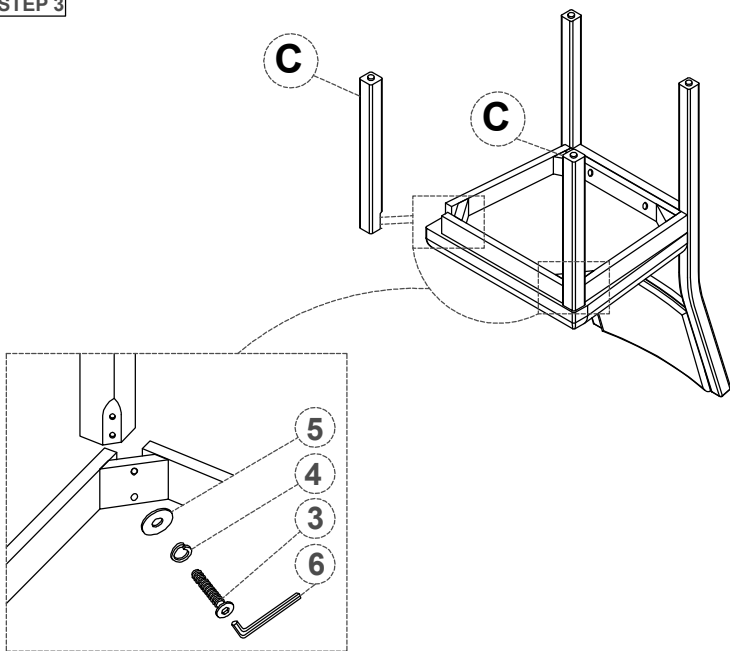

<b>Bolts</b> 1/4 x 70mm  ② x 4	<b>Spring Washer</b> 1/4 x 11mm x 1.5mm  ④ x 4	<b>Flat Washer</b> 1/4 x 16mm x 1.5mm  ⑤ x 4	<b>Allen Key</b> 4mm x 60mm  ⑥ x 1
---	--	--	--

**STEP 3**



<b>Bolts</b> 1/4 x 50mm  ③ x 4	<b>Spring Washer</b> 1/4 x 11mm x 1.5mm  ④ x 4	<b>Flat Washer</b> 1/4 x 16mm x 1.5mm  ⑤ x 4	<b>Allen Key</b> 4mm x 60mm  ⑥ x 1
---	--	--	--

**FINISHED**

