

ASSEMBLY INSTRUCTIONS

WF 311952 DINING TABLE

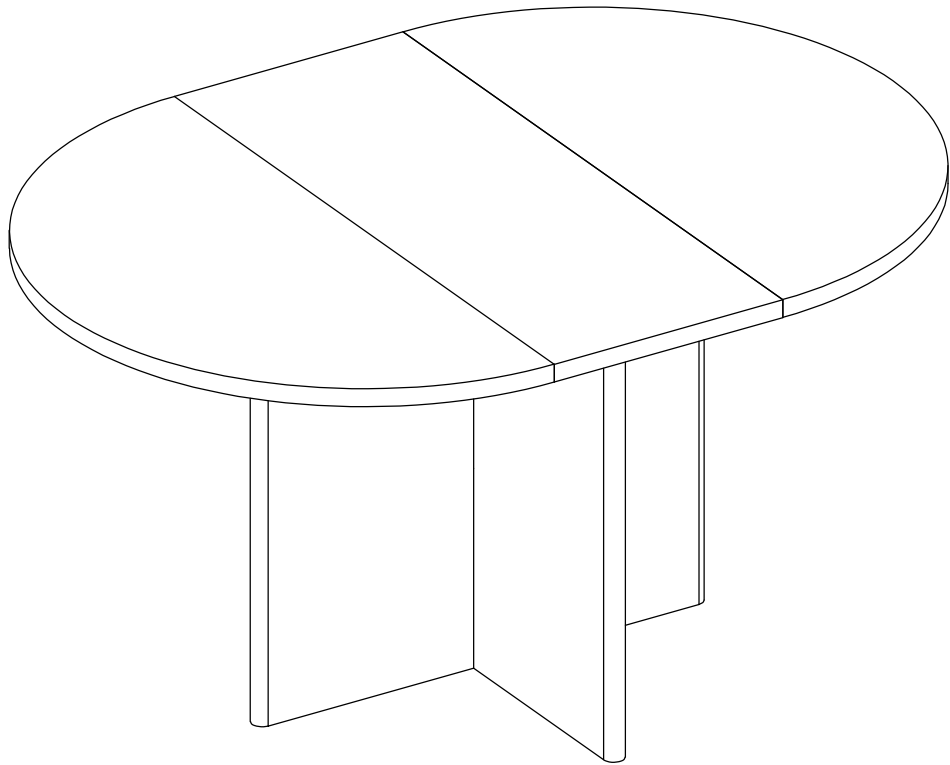





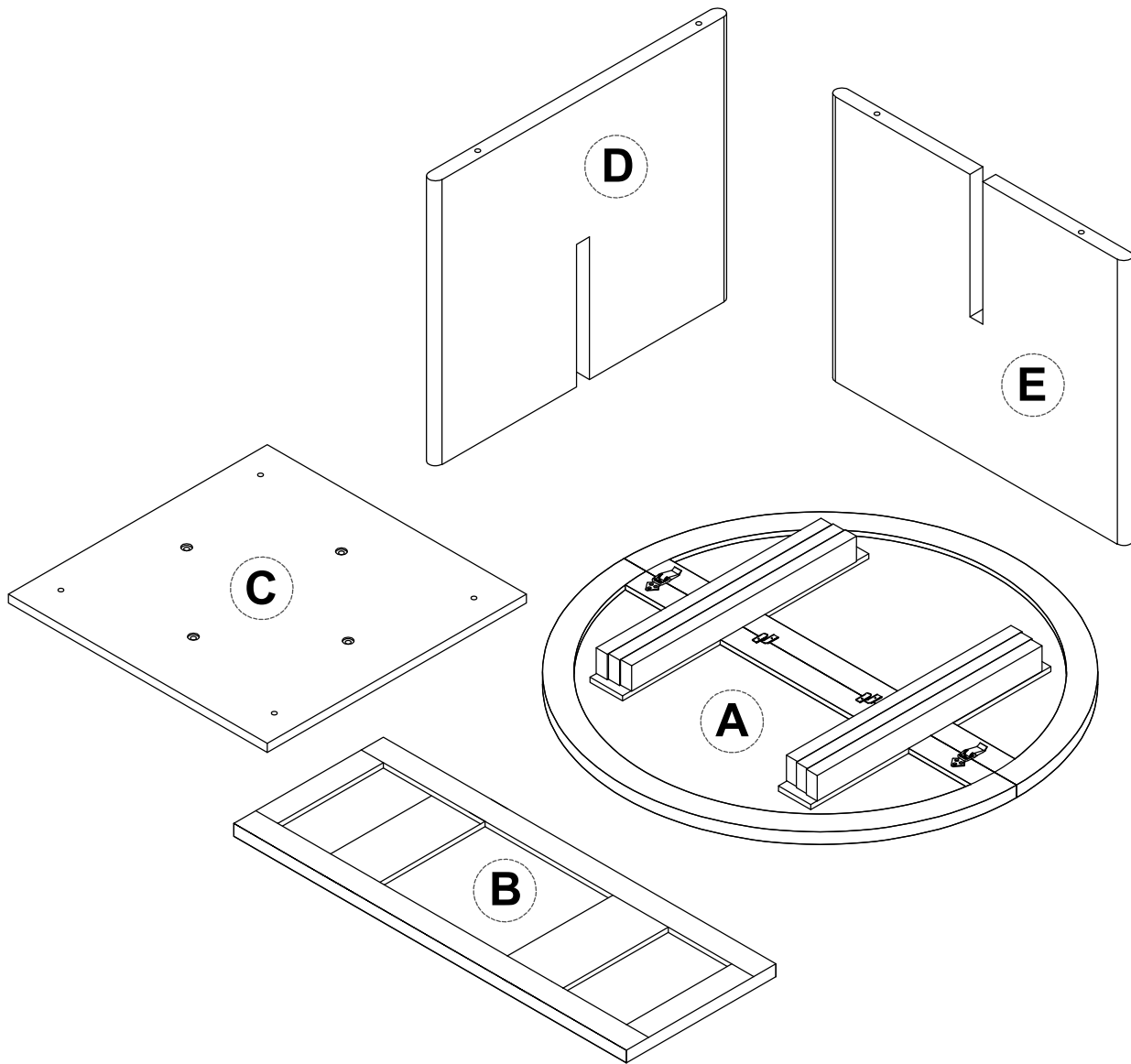

IMPORTANT NOTE:

- ① PLACE ALL PARTS ON A CLEAN AND SMOOTH SURFACE SUCH AS A RUG OR CARPET TO AVOID THE PARTS FROM BEING SCRATCHED.
- ② BEFORE YOU BEGIN, KINDLY FOLLOW THE ASSEMBLY INSTRUCTIONS STEP BY STEP.
- ③ DO NOT TIGHEN ALL SCREWS AND BOLTS UNTIL THE TABLE IS FULLY STEP-UP

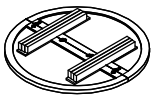

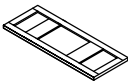
Part List For One

Hardware List For One

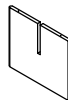
No	Parts Desc.	No	Hardware Desc.	Q'ty
A	TOP PANEL 	1	Bolts 5/16"* 40mm 	8pcs
		2	Spring Washer 5/16"* 13mm x 1.5mm 	8pcs
B	MOVABLE BOARD 	3	Flat Washer 5/16"* 16mm x 1.5mm 	8pcs
		4	Allen Key 4mm*60mm 	1pcs
D	TABLE LEGS 			
E	TABLE LEGS 			



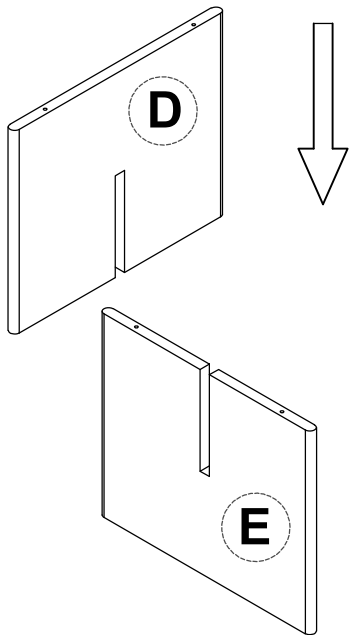

STEP 1

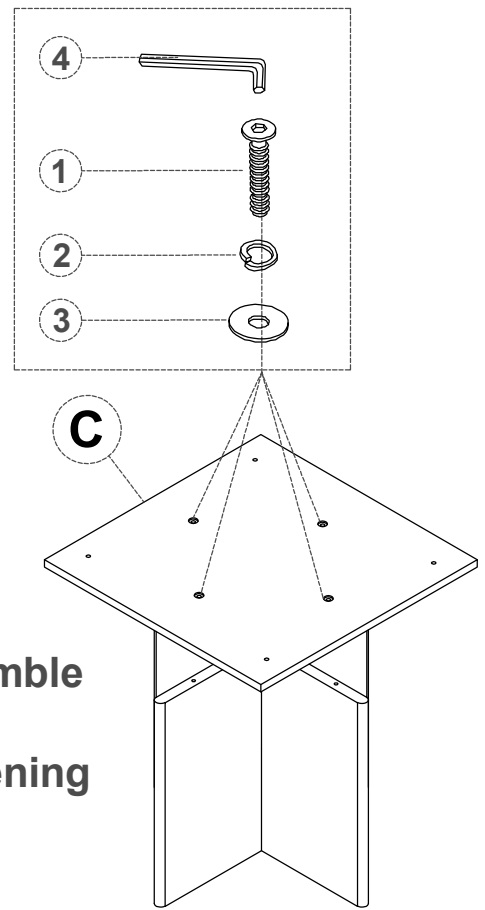

STEP 2







Please assemble
all the parts
before tightening
the bolts

Bolts 5/16 x 40mm  ① x 4	Spring Washer 5/16 x 11mm x 1.5mm  ② x 4	Flat Washer 1/4 x 16mm x 1.5mm  ③ x 4	Allen Key 4mm x 60mm  ④ x 1
---	---	--	--

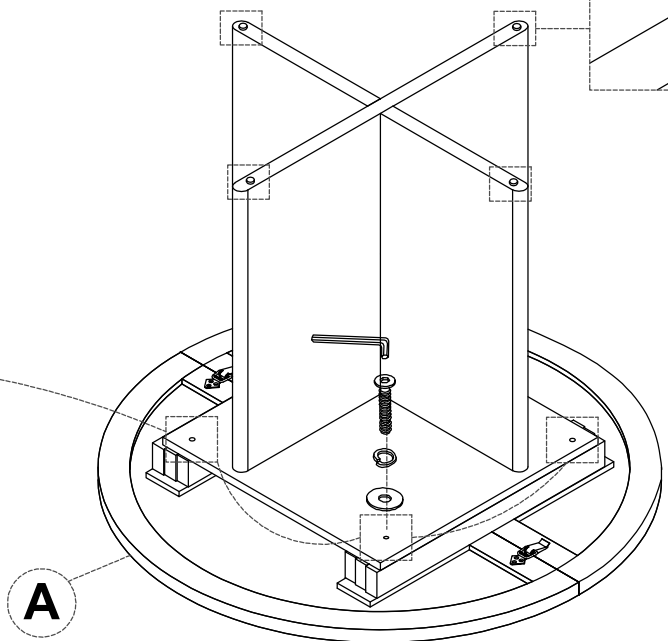
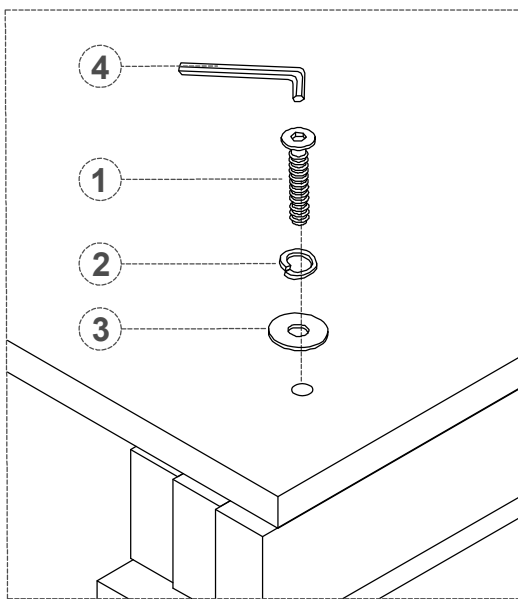
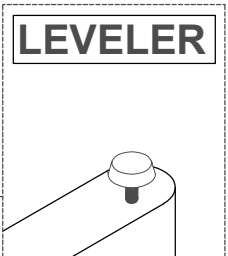
STEP 3

Please assemble all the parts
before tightening the bolts



Bolts 5/16 x 40mm  ① x 4	Spring Washer 5/16 x 11mm x 1.5mm  ② x 4	Flat Washer 1/4 x 16mm x 1.5mm  ③ x 4	Allen Key 4mm x 60mm  ④ x 1
--	---	--	--

STEP 4

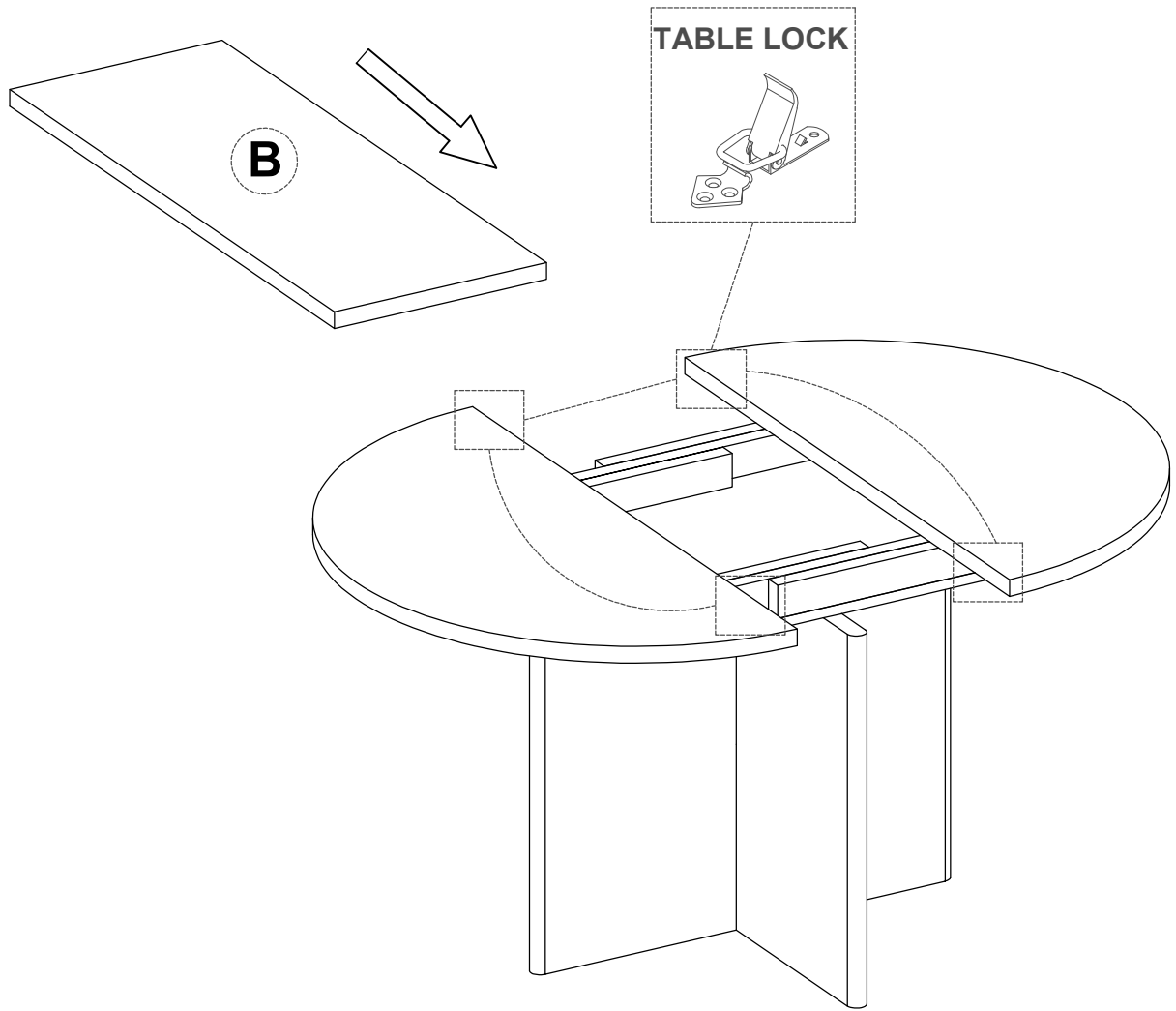

FINISHED

