

# ASSEMBLY INSTRUCCIONES

ITEM NOTE : WF310957

## DINING TABLE

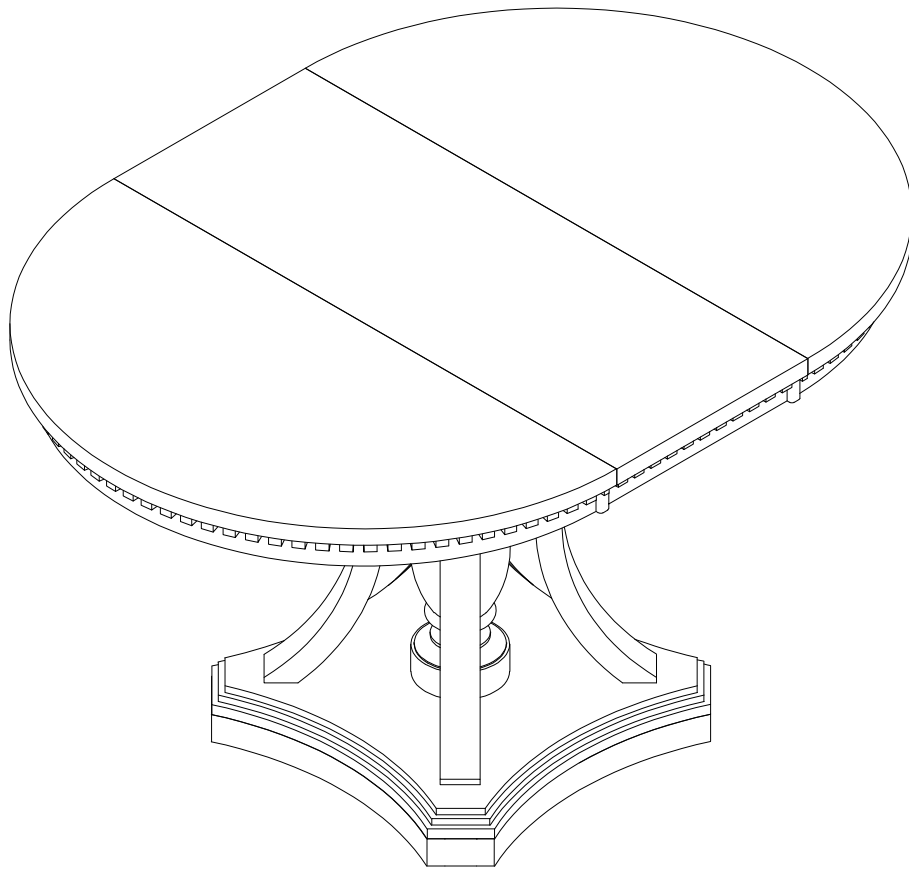





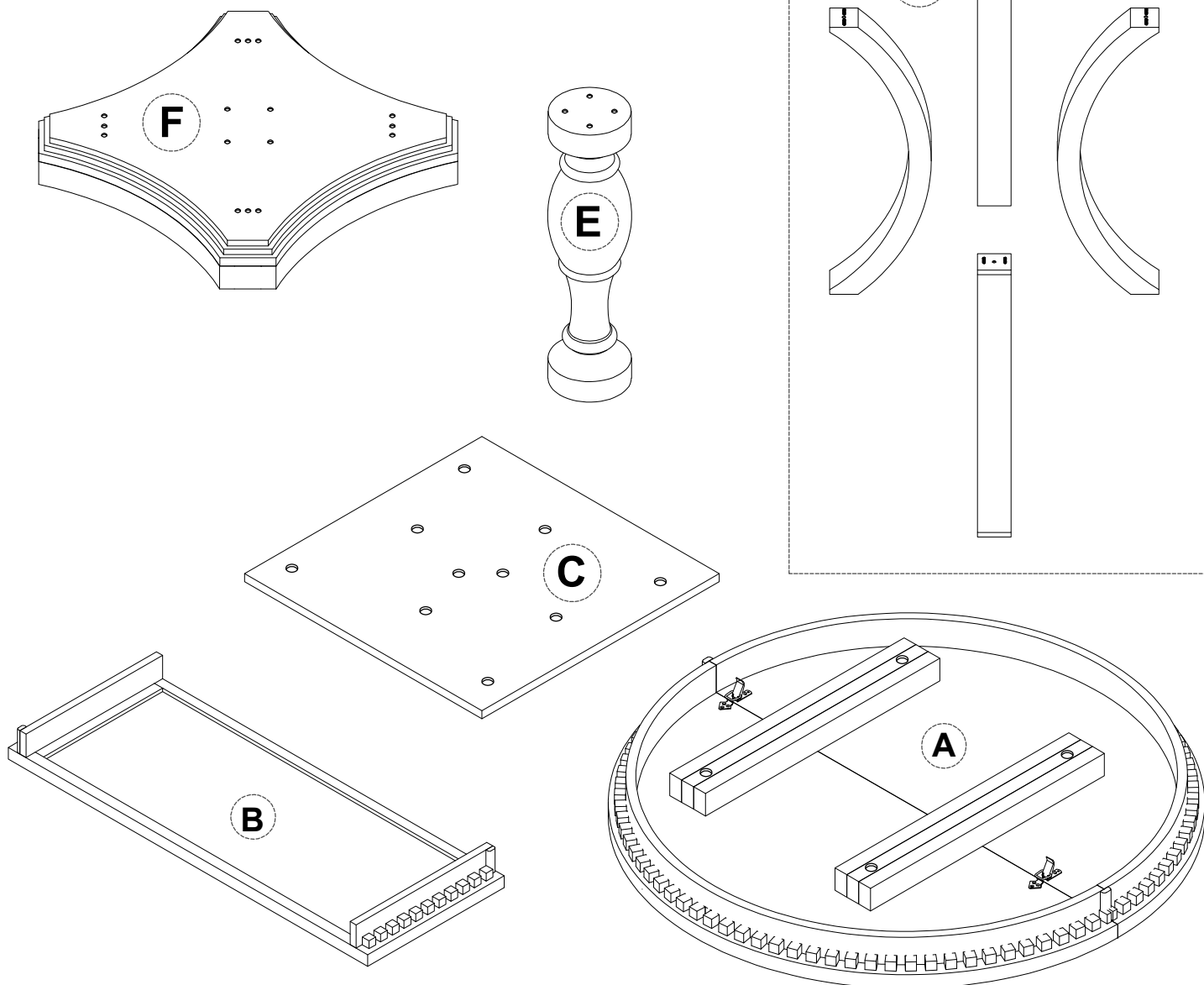

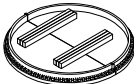
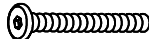
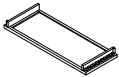
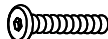
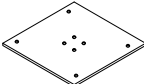
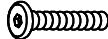

### IMPORTANT NOTE:

- ① PLACE ALL PARTS ON A CLEAN AND SMOOTH SURFACE SUCH AS A RUG OR CARPET TO AVOID THE PARTS FROM BEING SCRATCHED.
- ② BEFORE YOU BEGIN, KINDLY FOLLOW THE ASSEMBLY INSTRUCTIONS STEP BY STEP.
- ③ DO NOT TIGHTEN ALL SCREWS AND BOLTS UNTIL THE TABLE IS FULLY SET-UP

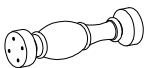

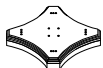



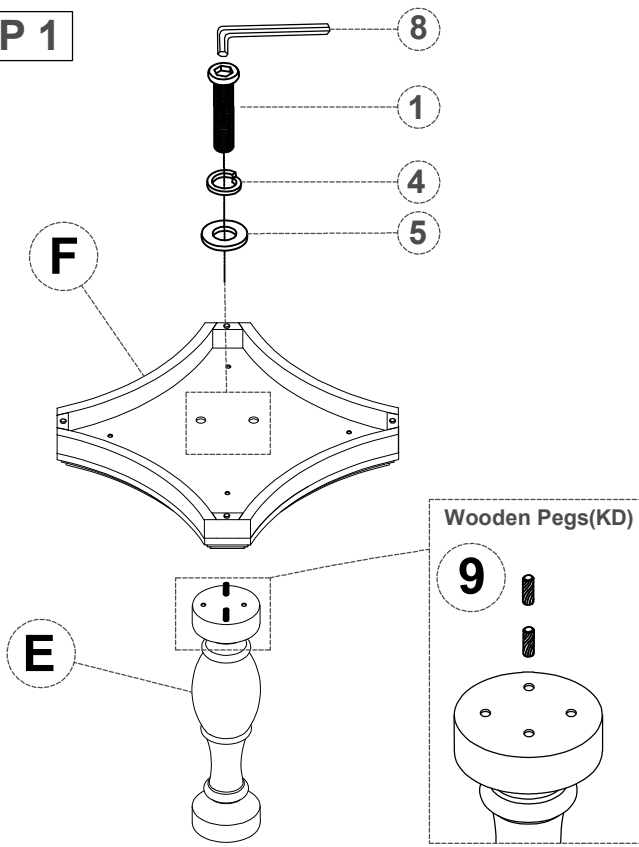

### Part List For One

### Hardware List For One

No	Parts Desc.	Q'ty	No	Hardware Desc.	Q'ty
A	TOP PANEL 	1pcs	1	Bolts 5/16" x 50mm 	4pcs
B	LFAF 	1pcs	2	Bolts 5/16" x 40mm 	4pcs
C	JOINT PLATE BETWEEN LEGS AND TABLETOP 	1pcs	3	Bolts 1/4" x 35mm 	8pcs
D	LEGS 	4pcs	4	Spring Washer 5/16" x 13mm x 1.5mm 	8pcs
E	LEGS 	1pcs	5	Flat Washer 5/16" x 16mm x 1.5mm 	8pcs
F	MIDDLE STRETCHER 	1pcs	6	Spring Washer 1/4" x 13mm x 1.5mm 	8pcs
			7	Flat Washer 1/4" x 16mm x 1.5mm 	8pcs
			8	Allen Key 4mm*60mm 	1pcs
			9	Wooden Pegs 	4pcs





### STEP 1

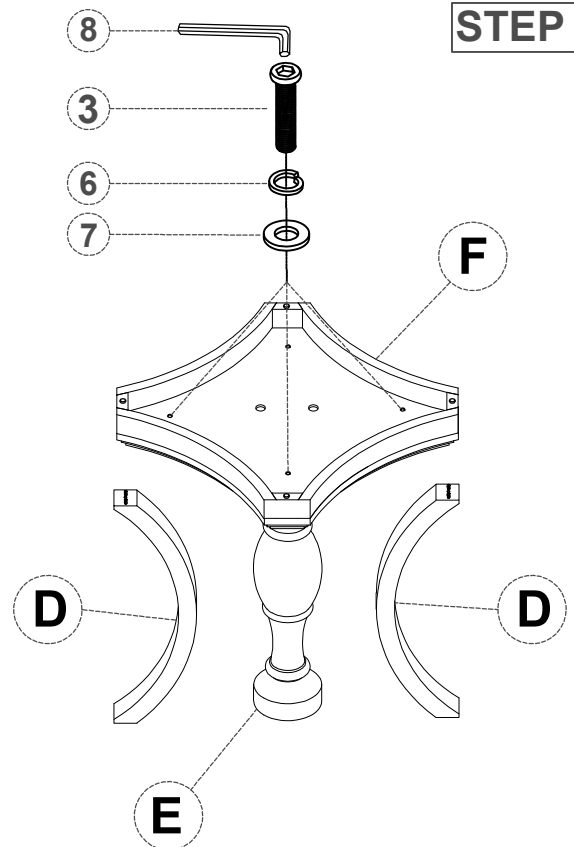

<b>Bolts</b> 5/16 x 50mm	<b>Spring Washer</b> 5/16 x 13mm x 1.5mm	<b>Flat Washer</b> 5/16 x 16mm x 1.5mm	<b>Allen Key</b> 4mm x 60mm	<b>Wooden Pegs</b>
 ① x 2	 ④ x 2	 ⑤ x 2	 ⑧ x 1	 ⑨ x 2





### STEP 2

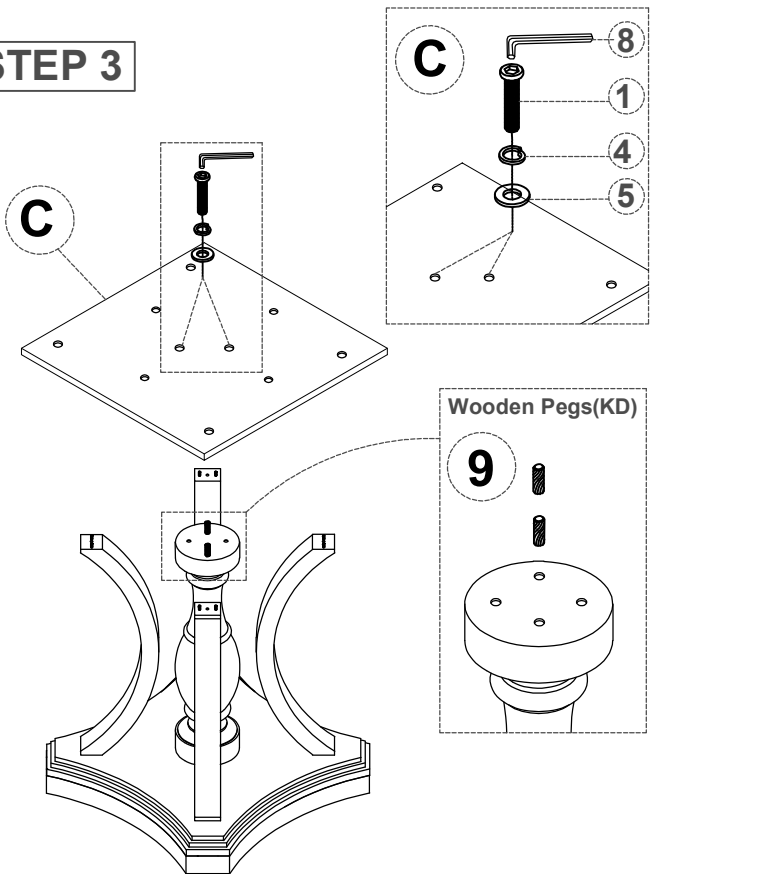

<b>Bolts</b> 1/4 x 35mm	<b>Spring Washer</b> 1/4 x 13mm x 1.5mm	<b>Flat Washer</b> 1/4 x 16mm x 1.5mm	<b>Allen Key</b> 4mm x 60mm
 ③ x 4	 ⑥ x 4	 ⑦ x 4	 ⑧ x 1





### STEP 3

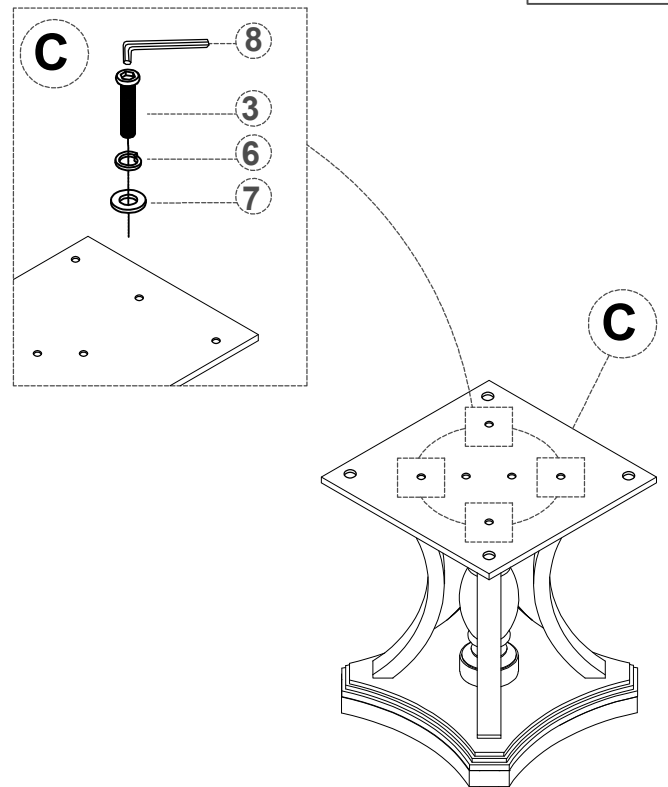

<b>Bolts</b> 5/16 x 50mm	<b>Spring Washer</b> 5/16 x 13mm x 1.5mm	<b>Flat Washer</b> 5/16 x 16mm x 1.5mm	<b>Allen Key</b> 4mm x 60mm	<b>Wooden Pegs</b>
 ① x 2	 ④ x 2	 ⑤ x 2	 ⑧ x 1	 ⑨ x 2

### STEP 4



<b>Bolts</b> 1/4 x 35mm	<b>Spring Washer</b> 1/4 x 13mm x 1.5mm	<b>Flat Washer</b> 1/4 x 16mm x 1.5mm	<b>Allen Key</b> 4mm x 60mm
 ③ x 4	 ⑥ x 4	 ⑦ x 4	 ⑧ x 1

# STEP 5

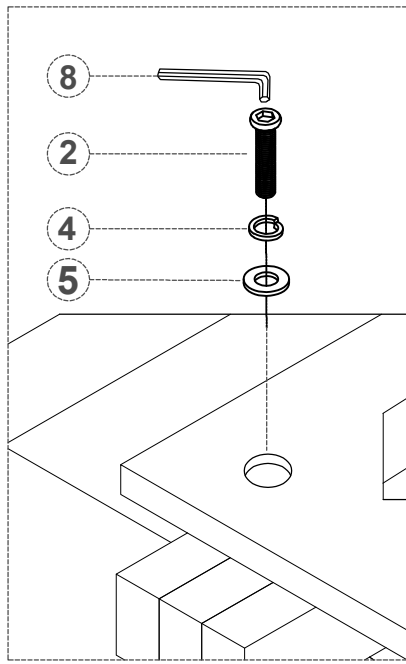

Adjust leg

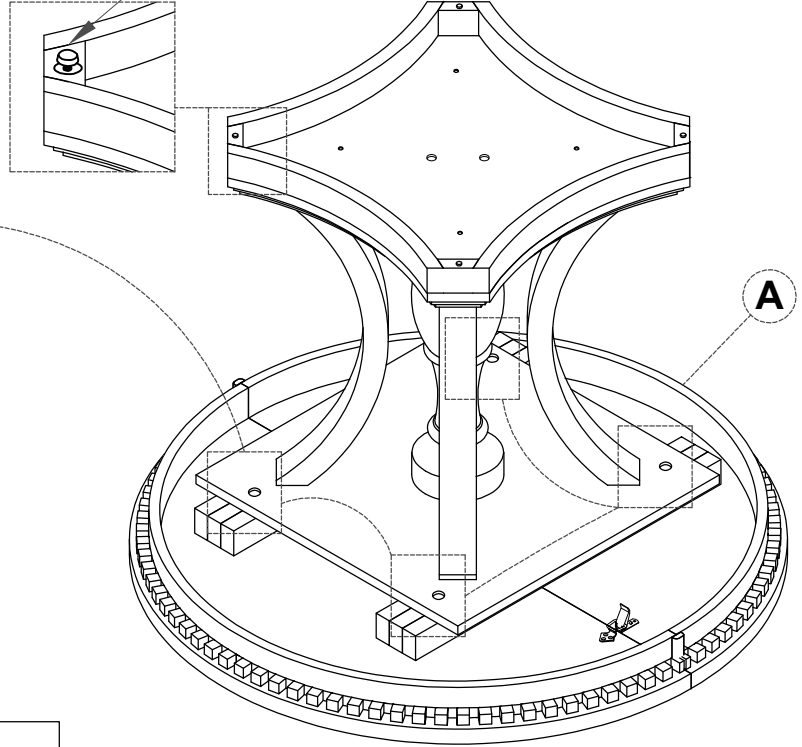

Bolts  
5/16 x 40mm



② x 4

Spring Washer  
5/16 x 13mm x 1.5mm



④ x 4

Flat Washer  
5/16 x 16mm x 1.5mm



⑤ x 4

Allen Key  
4mm x 60mm



⑧ x 1

# FINISH

