

ASSEMBLY INSTRUCTIONS

ITEM NO.WF311400

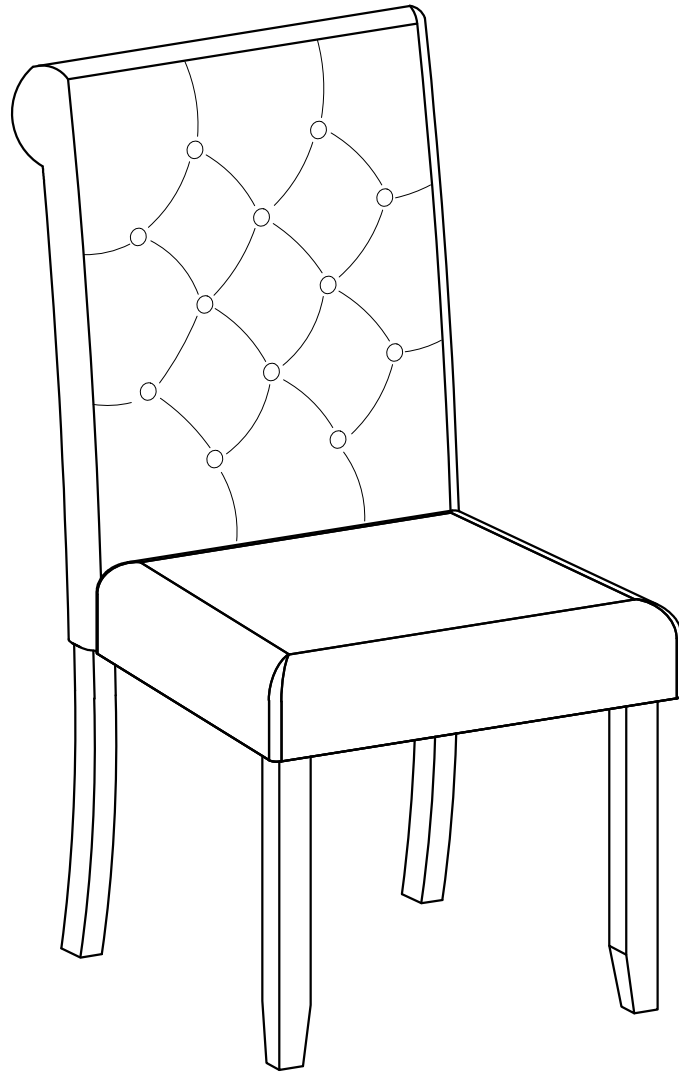



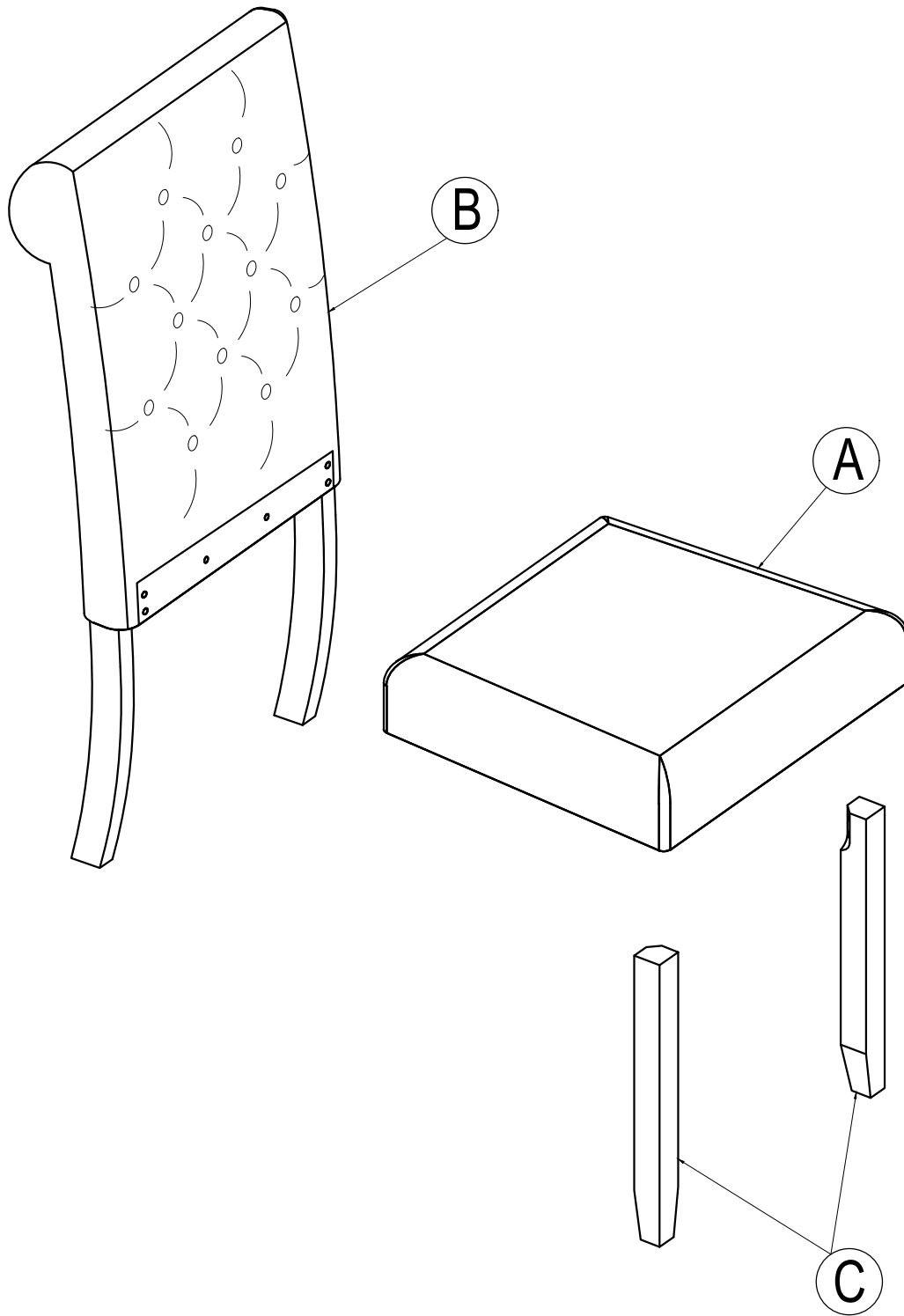

IMPORTANT NOTE :

- ① PLACE ALL PARTS ON A CLEAN AND SMOOTH SURFACE SUCH AS A RUG OR CARPET TO AVOID THE PARTS FROM BEING SCRATCHED.
- ② BEFORE YOU BEGIN,KINDLY FOLLOW THE ASSEMBLY INSTRUCTIONS STEP BY STEP.
- ③ DO NOT TIGHTEN ALL SCREWS AND BOLTS UNTIL THE CHAIR IS FULLY SET-UP.

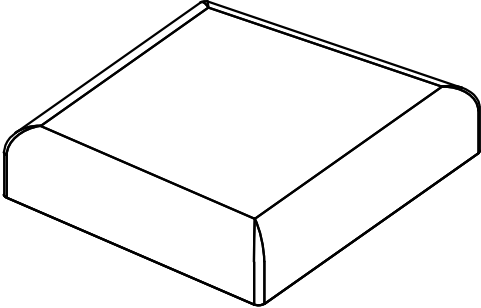
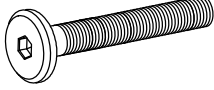
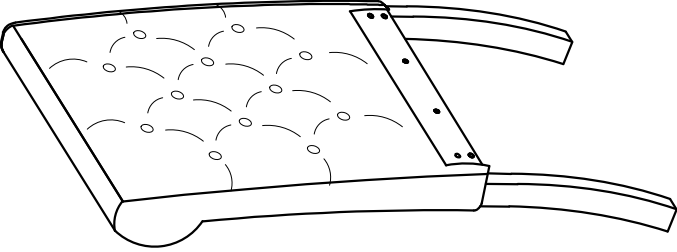
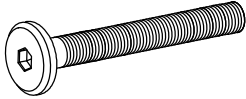
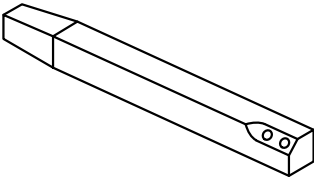
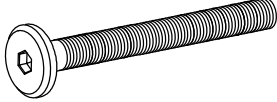

Part List

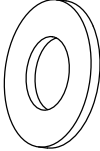
Hardware List

| | |
|--|---|
| <p>Ⓐ</p>  | <p>①</p>  <p>Ø 1/4" x 40mm</p> |
| <p>SEAT CHAIR (4 pcs)</p> | <p>BOLT (8 pcs)</p> |
| <p>Ⓑ</p>  | <p>②</p>  <p>Ø 1/4" x 55mm</p> |
| <p>BACK CHAIR (4 pcs)</p> | <p>BOLT (16 pcs)</p> |
| <p>Ⓒ</p>  | <p>③</p>  <p>Ø 1/4" x 75mm</p> |
| <p>LEG FRONT (8 pcs)</p> | <p>BOLT (16 pcs)</p> |
| | <p>④</p>  <p>Ø5/16" x 13mm</p> |
| | <p>FLAT WASHER (40pcs)</p> |
| | <p>⑤</p>  <p>Ø5/16" x 19mm</p> |
| | <p>LOCK WASHER (40pcs)</p> |
| | <p>⑥</p>  <p>4mm</p> |
| | <p>ALLEN KEY (1pc)</p> |

STEP 1

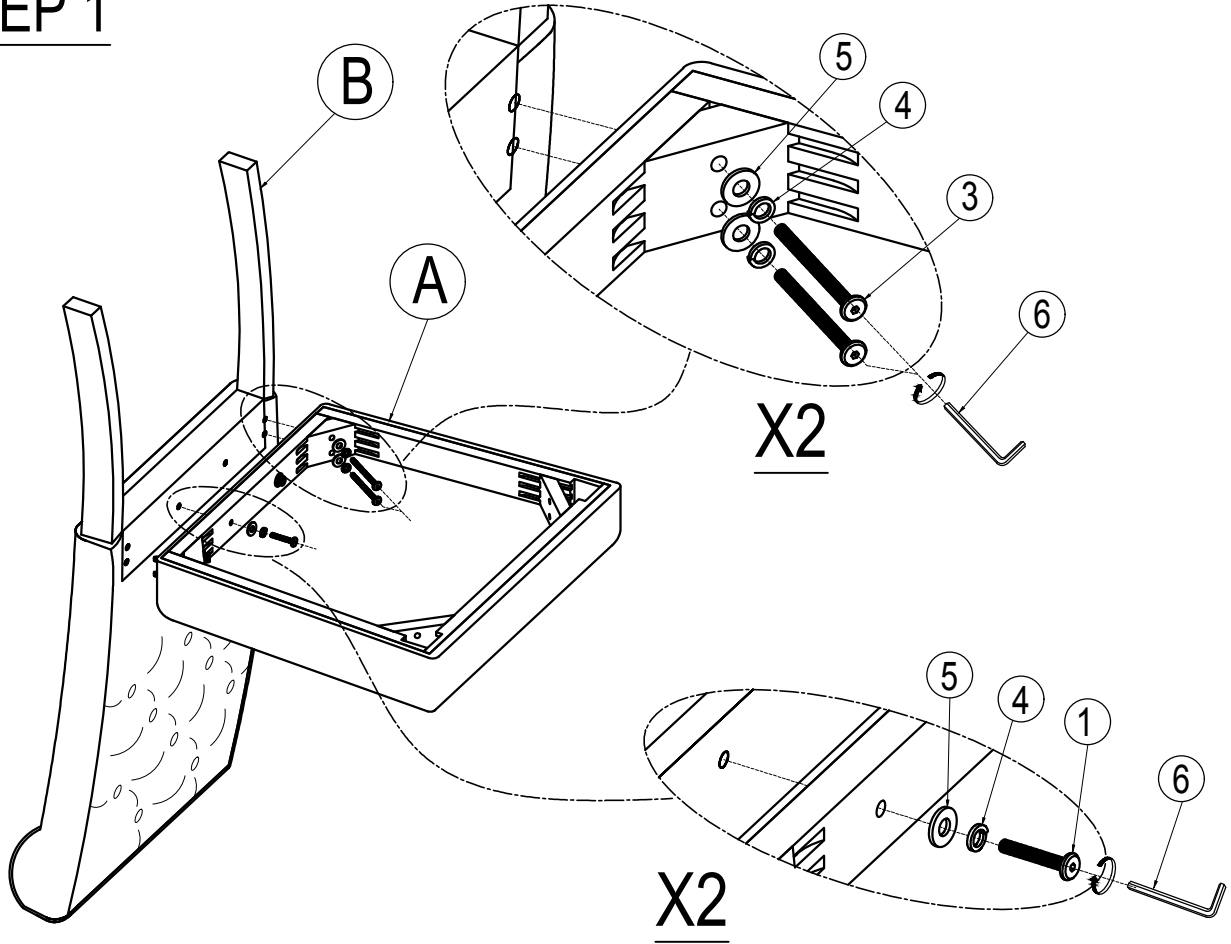

STEP 2

