

ASSEMBLY INSTRUCTIONS
Item No : WF304838AAB/AAK/AAE
Description : SIDEBOARD

Thank you for purchasing this quality product. Be sure to check all packing material carefully for small part that may have come loose inside carton during shipment.

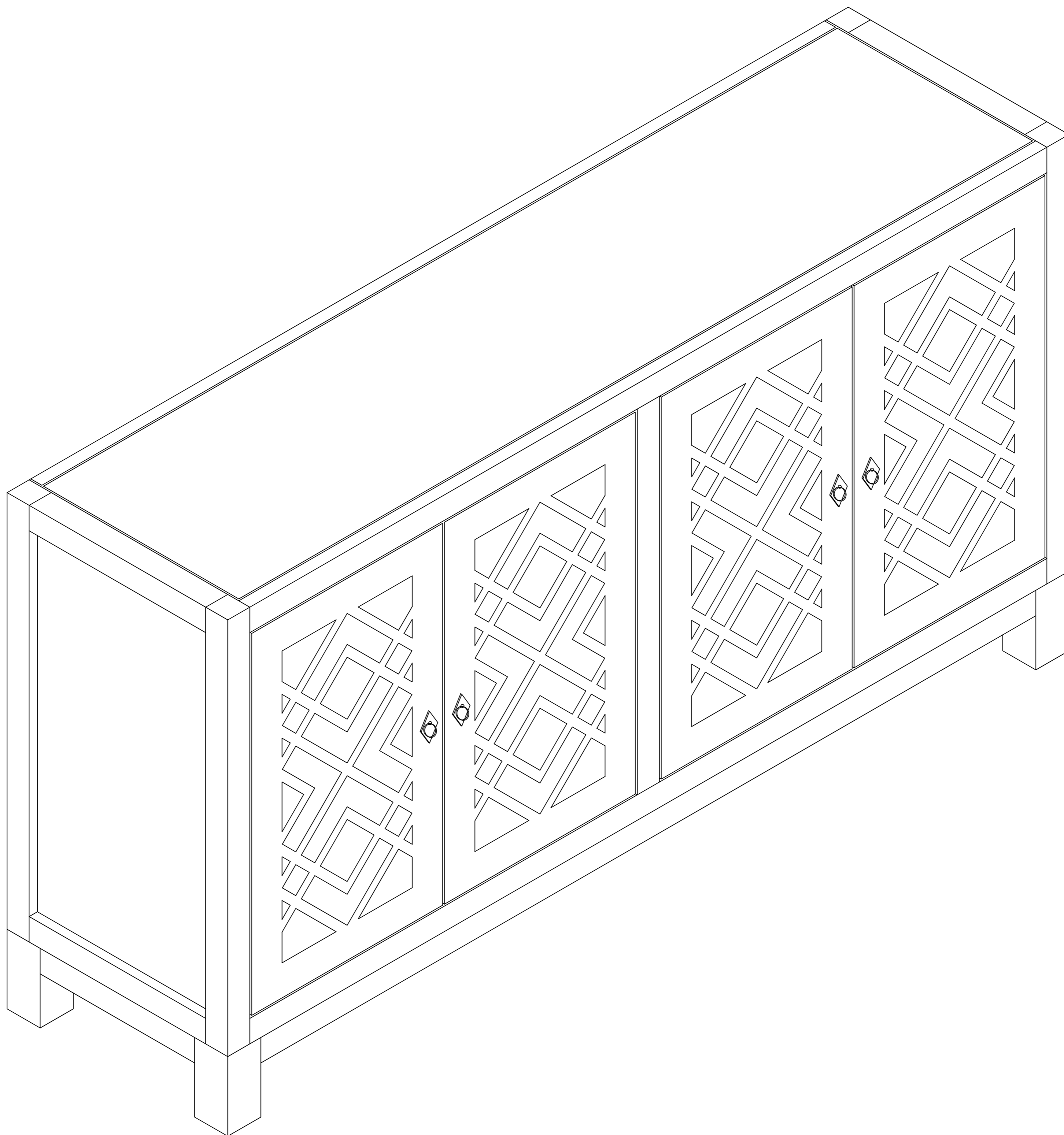

WF304838AAB/AAK/AAE

ASSEMBLY INSTRUCTIONS

Item No : WF304838AAB/AAK/AAE

Description : SIDEBOARD

Thank you for purchasing this quality product. Be sure to check all packing material carefully for small part that may have come loose inside carton during shipment.

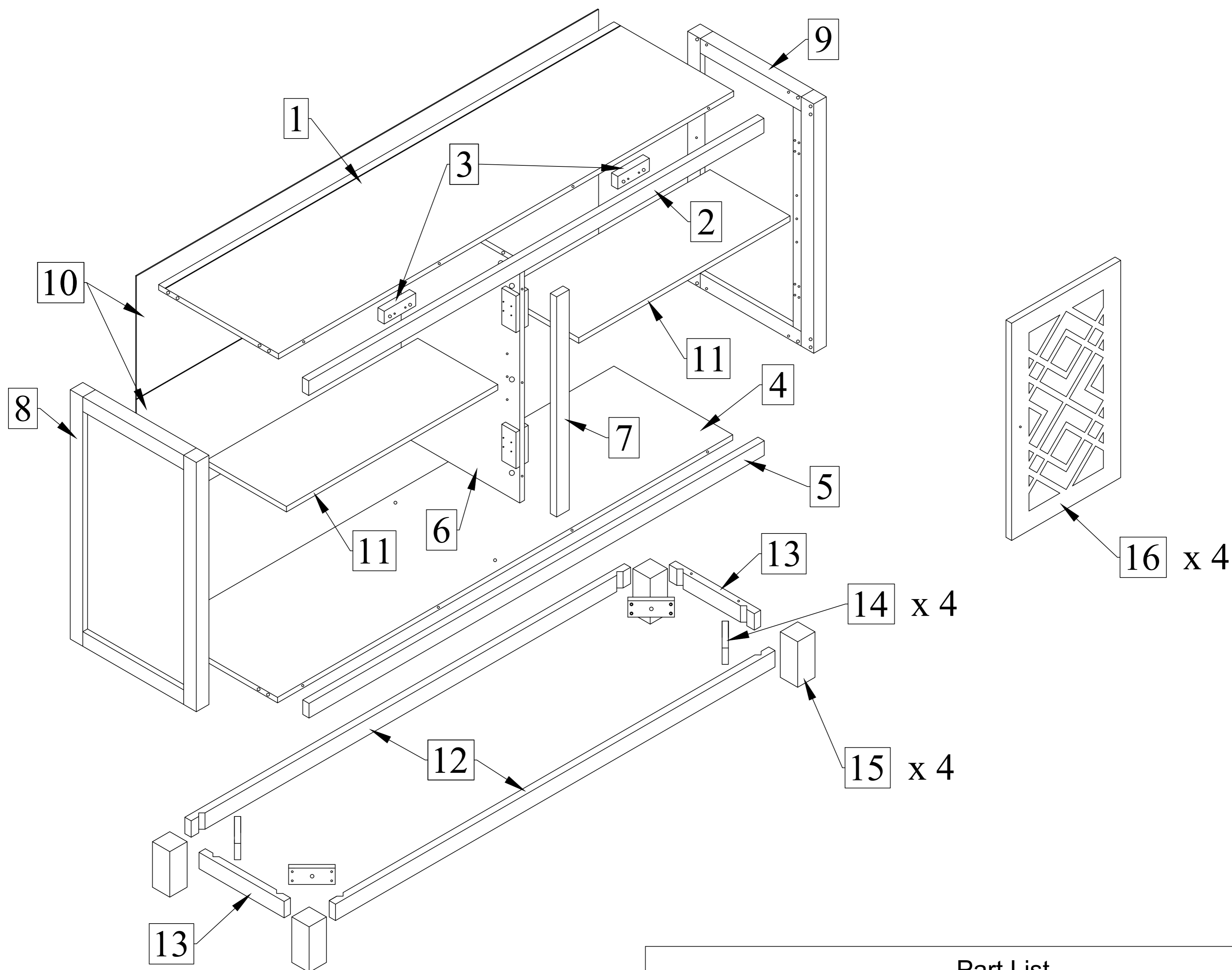

TOOLS REQUIRED (Not provided)

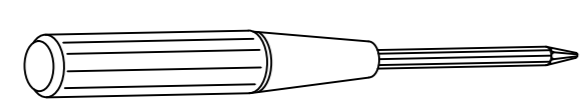

Screwdriver

Hardware List

No.	Description	Sketch	Quantity
A	Wood Dowel M8x30MM		24PCS
B	Minifix + Cap	B1 B2	21SETS
C	Metal Shelf Support		8PCS
D	Soft Close Hinges 7/8		8PCS
E	Screw M3.5 x 16MM		94PCS
F	H Connector		1PC
G	Screw M4 x 32MM		37PCS
H	JCBC M6 x 45MM		4PCS
I	Spring Washer		4PCS
J	Flat Washer		4PCS
K	Allen Key M5		1PC
L	Handle with Screw		4SETS

Part List

No.	Description	Sketch	Quantity
1	Top Panel		1PC
2	Top Rail		1PC
3	Door Stopper		2PCS
4	Bottom Panel		1PC
5	Bottom Rail		1PC
6	Center Panel		1PC
7	Center Rail		1PC
8	Side Panel - L		1PC
9	Side Panel - R		1PC
10	Back Panel		2PCS
11	Shelves		2PCS
12	Leg Frame		2PCS
13	Leg Frame		2PCS
14	Leg Frame Connector		4PCS
15	Leg		4PCS
16	Doors		4PCS

ASSEMBLY INSTRUCTIONS

Item No : WF304838AAB/AAK/AAE

Description : SIDEBOARD

Thank you for purchasing this quality product. Be sure to check all packing material carefully for small part that may have come loose inside carton during shipment.

Step 1 : Attach Wood Dowel (A) and Minifix (B1) to parts (1,2,4,5,6,7,8,9) accordingly. Attach Metal Shelf Support (C) to Center & Side Panels (6,8,9). Attach Hinges (D) to Doors (16) with Screw (E). Slot Back Panel (10) into H Connector (F).

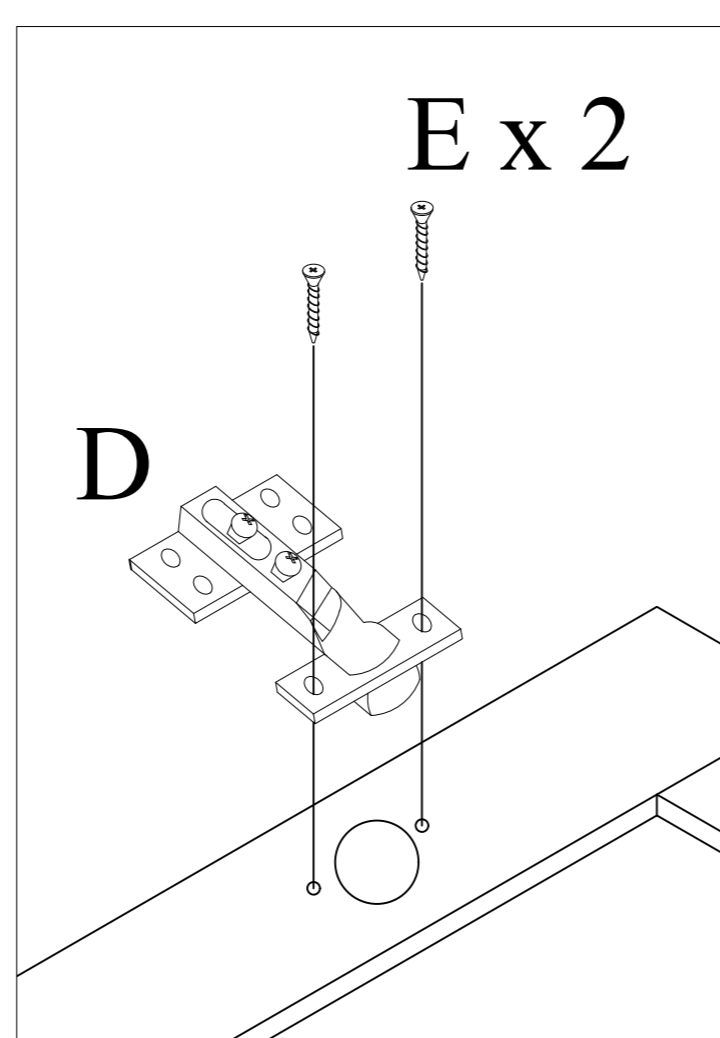
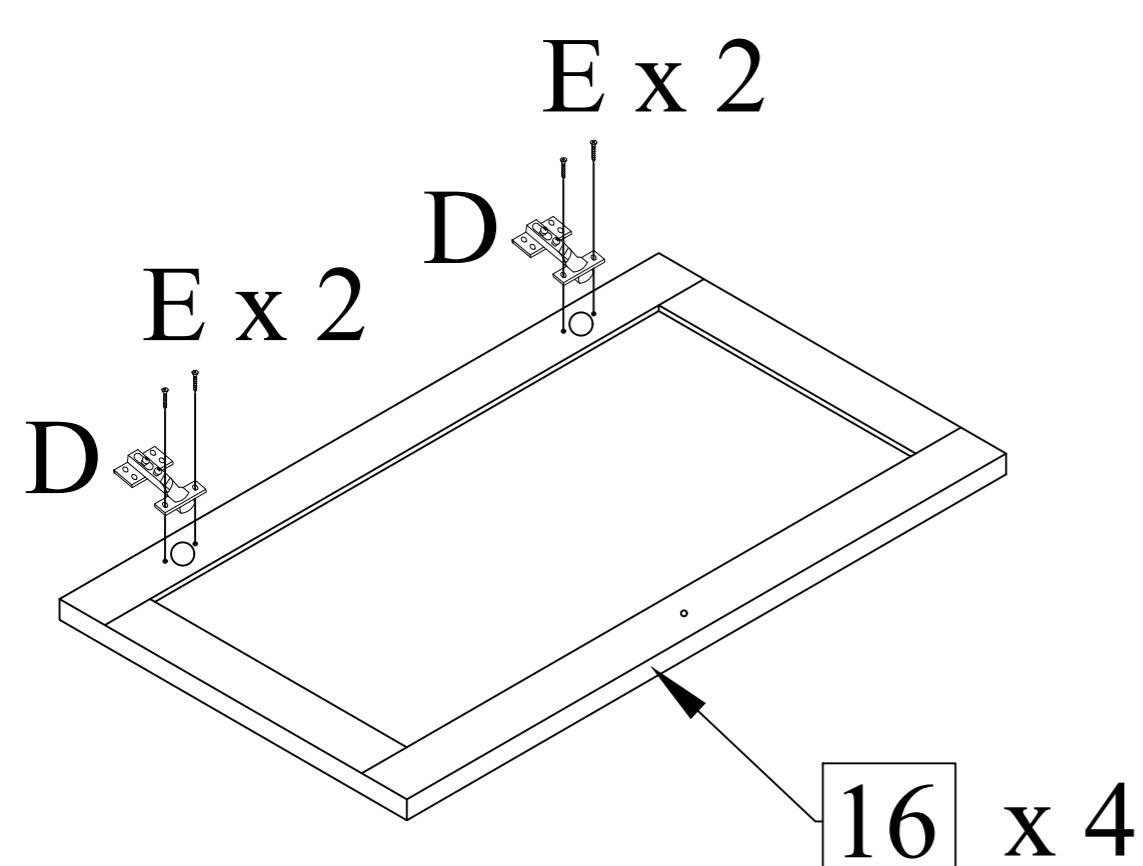
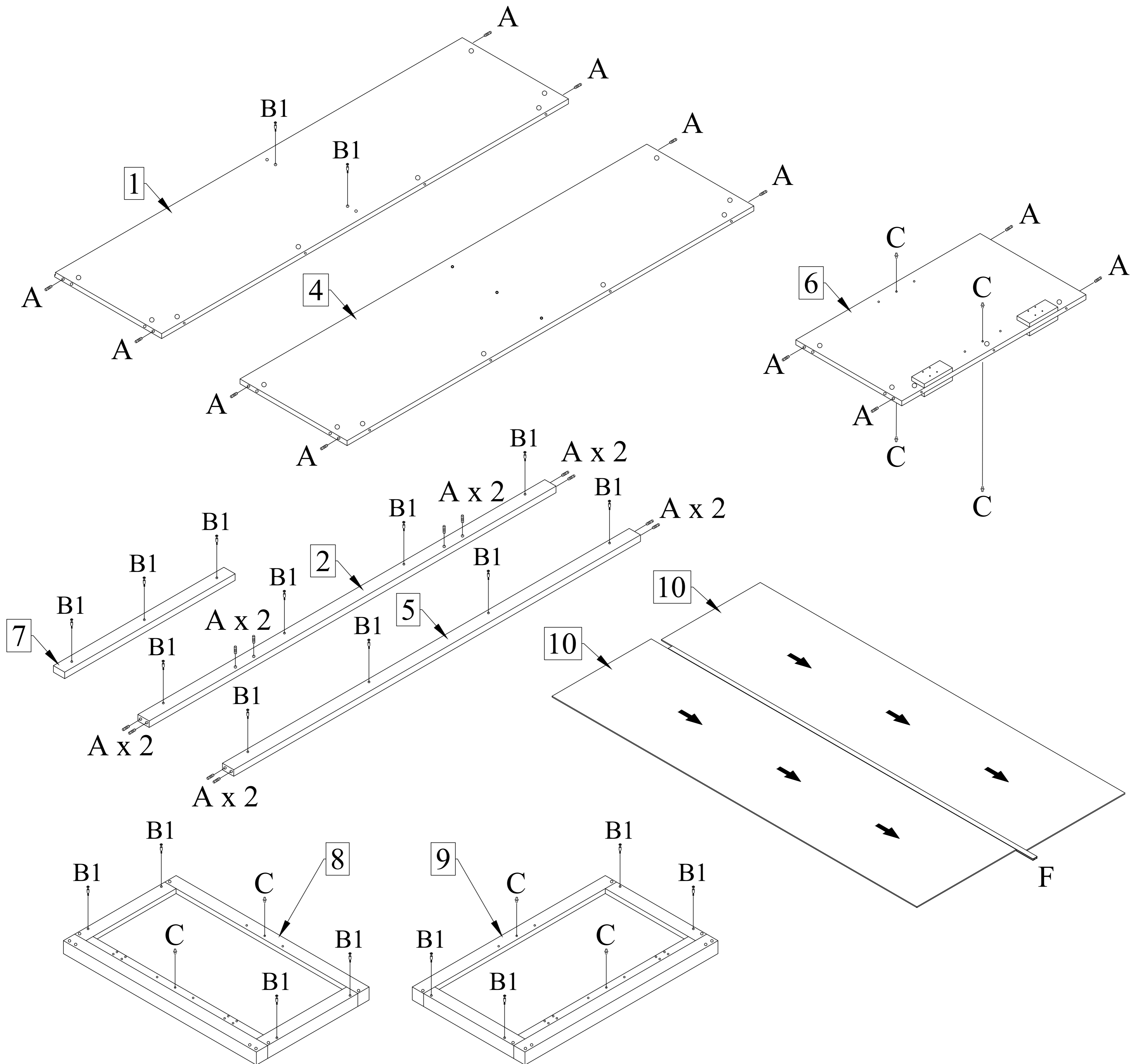

A	Wood Dowel M8x30MM		24PCS
B	Minifix + Cap		21PCS
C	Metal Shelf Support		8PCS
D	Soft Close Hinges 7/8		8PCS
E	Screw M3.5 x 16MM		16PCS
F	H Connector		1PC

ASSEMBLY INSTRUCTIONS

Item No : WF304838AAB/AAK/AAE

Description : SIDEBOARD

Thank you for purchasing this quality product. Be sure to check all packing material carefully for small part that may have come loose inside carton during shipment.

Step 2 : Attach Door Stopper (3) to Top Rail (2) using Screw (G). Attach the connected part (2,3) to Top Panel (1) and lock Minifix Cap (B2). Connect Bottom Rail (5) to Bottom Panel (4) and lock Minifix Cap (B2). Connect Center Rail (7) to Center Panel (6) and lock Minifix Cap(B2).

B	Minifix Cap	B2	11PCS
G	Screw M4 x 32MM		4PCS

Lock Minifix cap clockwise

Step 3 : Connect Center Panel (6,7) to Top Panel (1,2,3) and lock Minifix Cap (B2). Then, connect it with Bottom Panel (4,5) using Screw (G)

B	Minifix Cap	B2	2PCS
G	Screw M4 x 32MM		3PCS

Lock Minifix cap clockwise

ASSEMBLY INSTRUCTIONS

Item No : WF304838AAB/AAK/AAE

Description : SIDEBOARD

Thank you for purchasing this quality product. Be sure to check all packing material carefully for small part that may have come loose inside carton during shipment.

Step 4 : Connect Side Panels (8,9) to the assembled parts and lock Minifix Cap (B2).

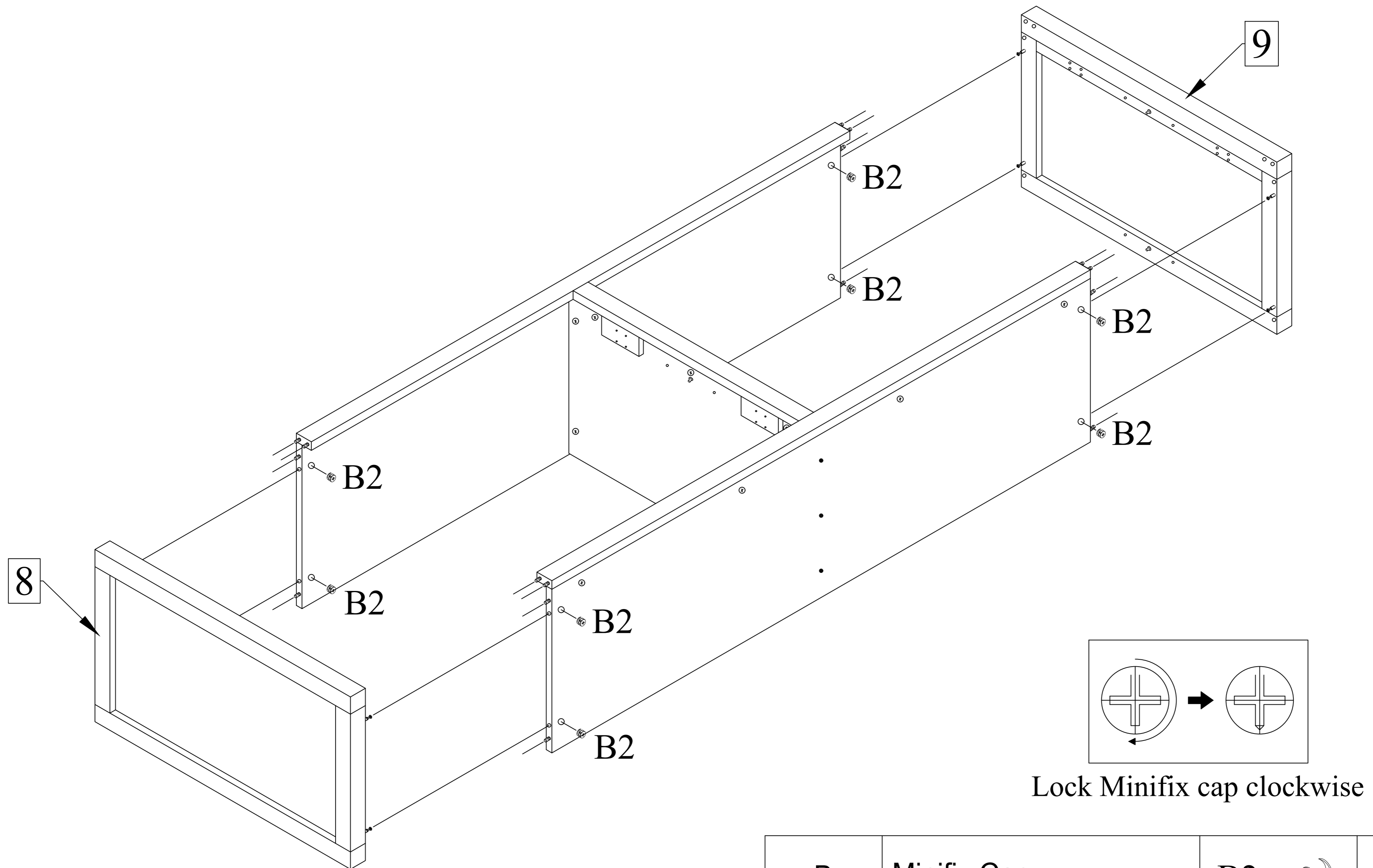

B	Minifix Cap	B2	8PCS
---	-------------	----	------

Step 5 : Insert Back Panel (10) from behind using Screw (E).

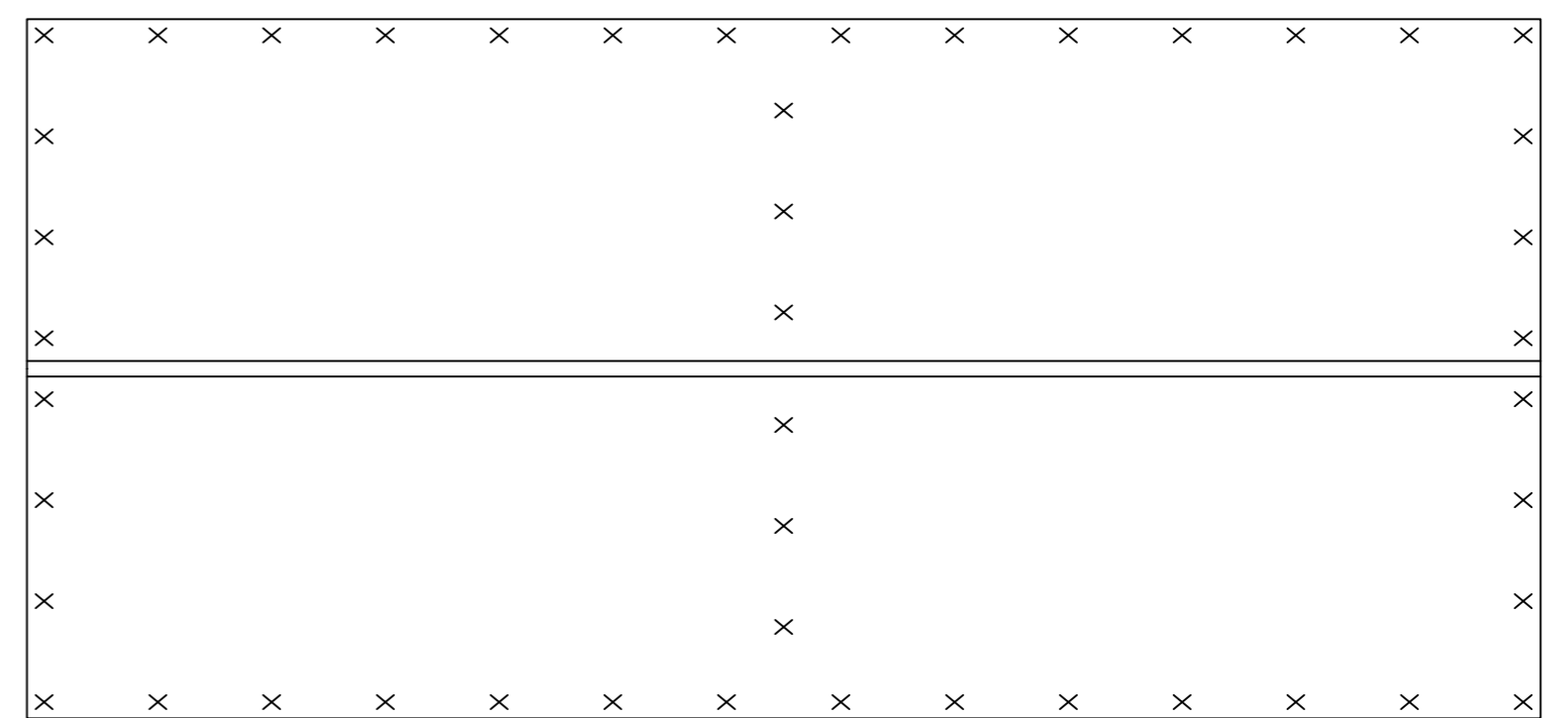
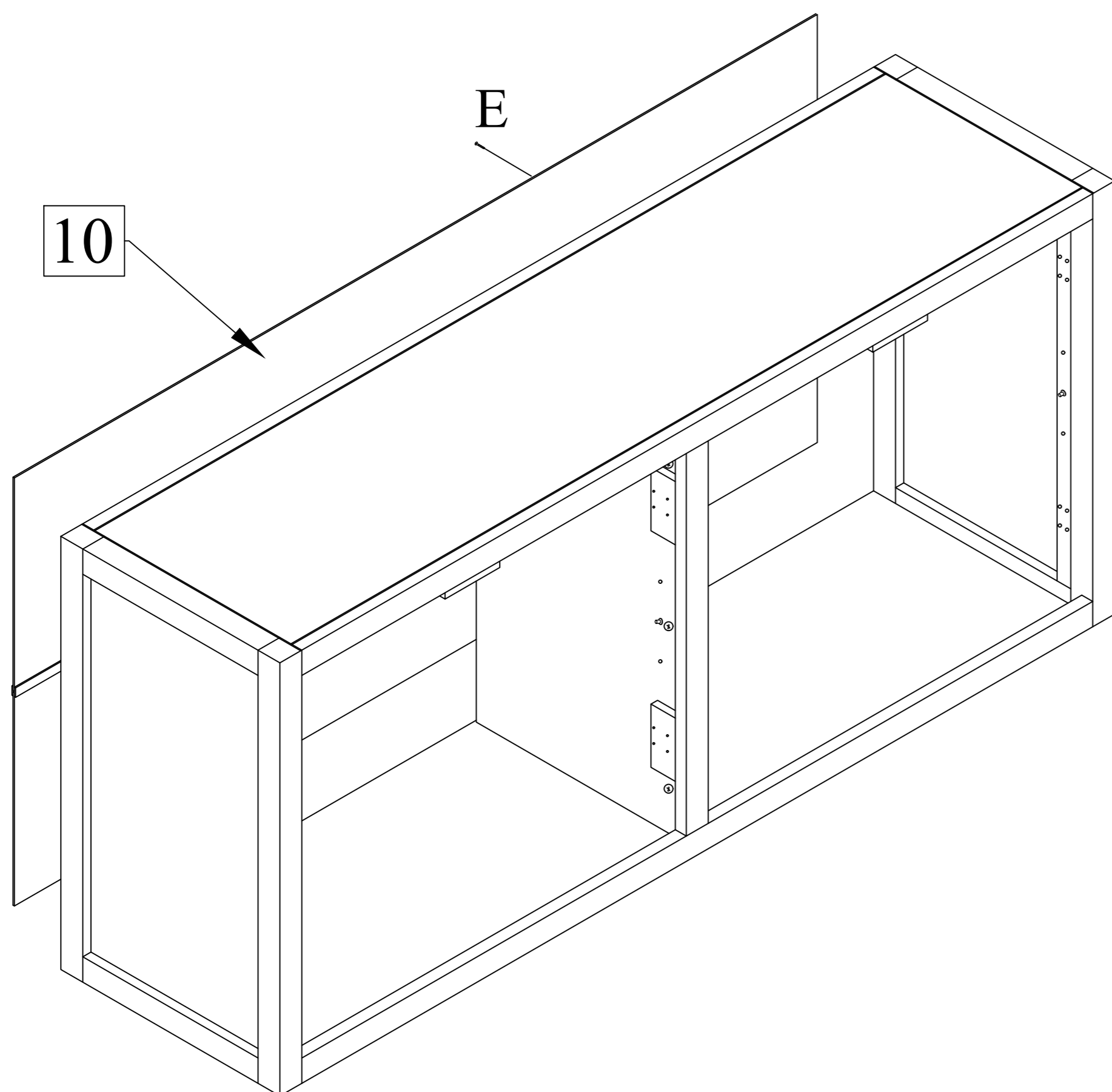

Guidance of screw array

E	Screw M3.5 x 16MM		46PCS
---	-------------------	--	-------

ASSEMBLY INSTRUCTIONS

Item No : WF304838AAB/AAK/AAE

Description : SIDEBOARD

Thank you for purchasing this quality product. Be sure to check all packing material carefully for small part that may have come loose inside carton during shipment.

Step 6 : Assemble Leg Frame (12,13,14) with Screw (G). Attach Leg (15) onto in with JCBC and Washer (H,I,J) using Allen Key (K). Then, turn sideboard upside-down and attach leg frame onto it using Screw (G).

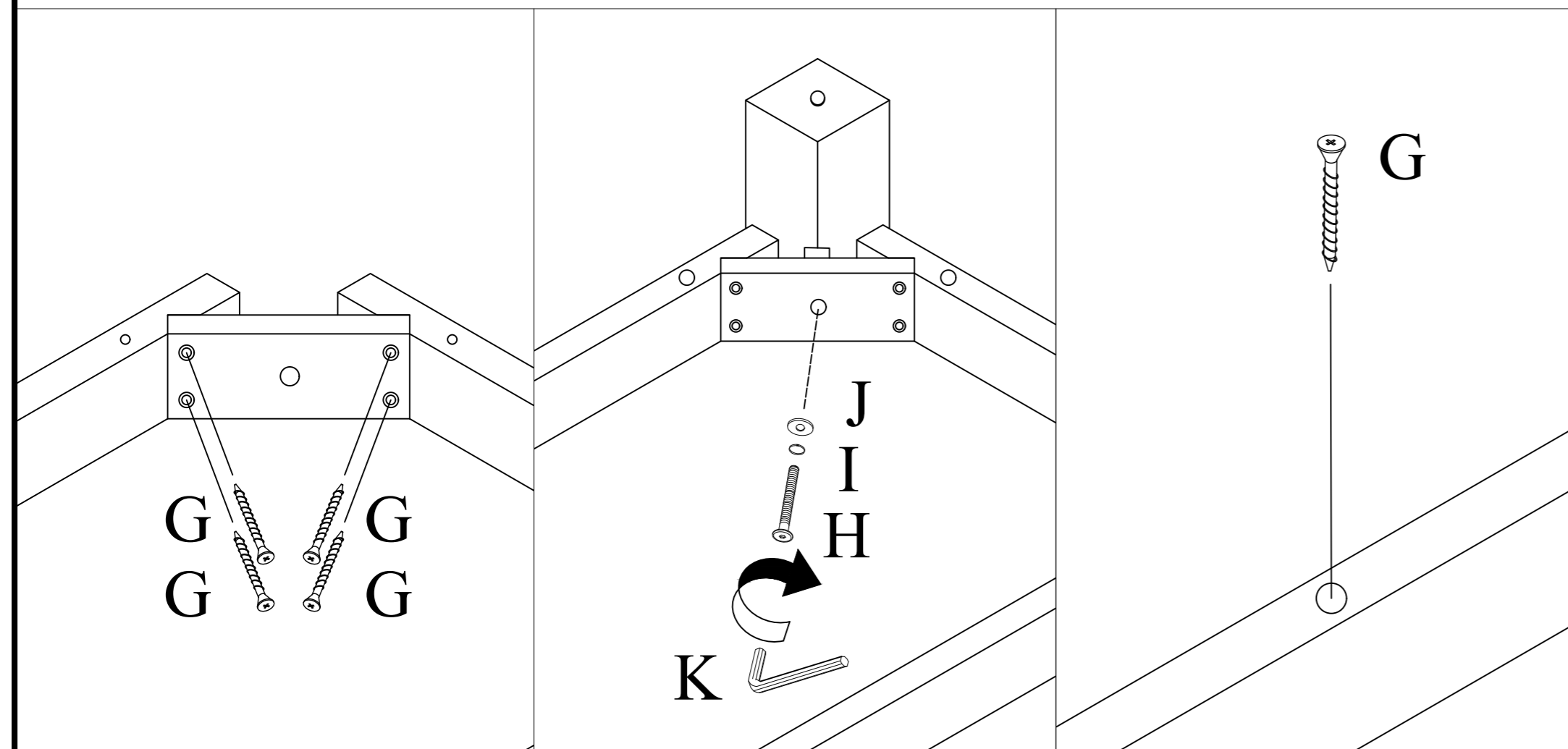
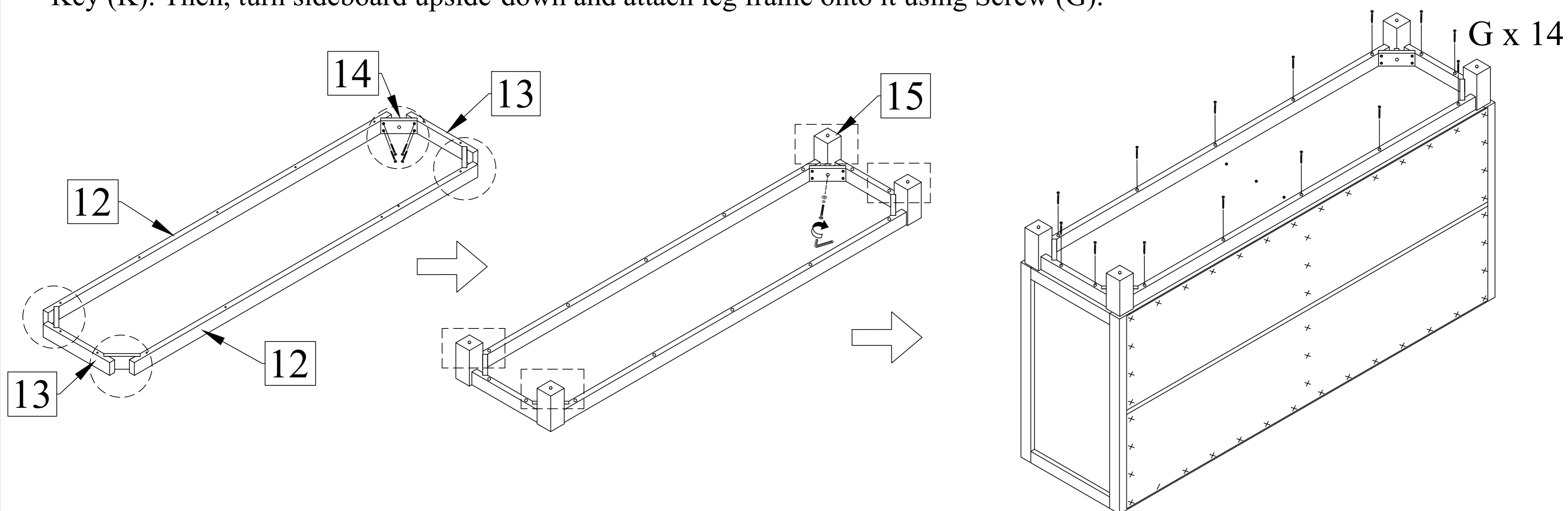

G	Screw M4 x 32MM		30PCS
H	JCBC M6 x 45MM		4PCS
I	Spring Washer		4PCS
J	Flat Washer		4PCS
K	Allen Key M4		1PC

Step 7 : Turn the sideboard and put Shelves (11) in. Attach Doors (16) using Screw (E). Attach Handle (L). Completed Assembly.

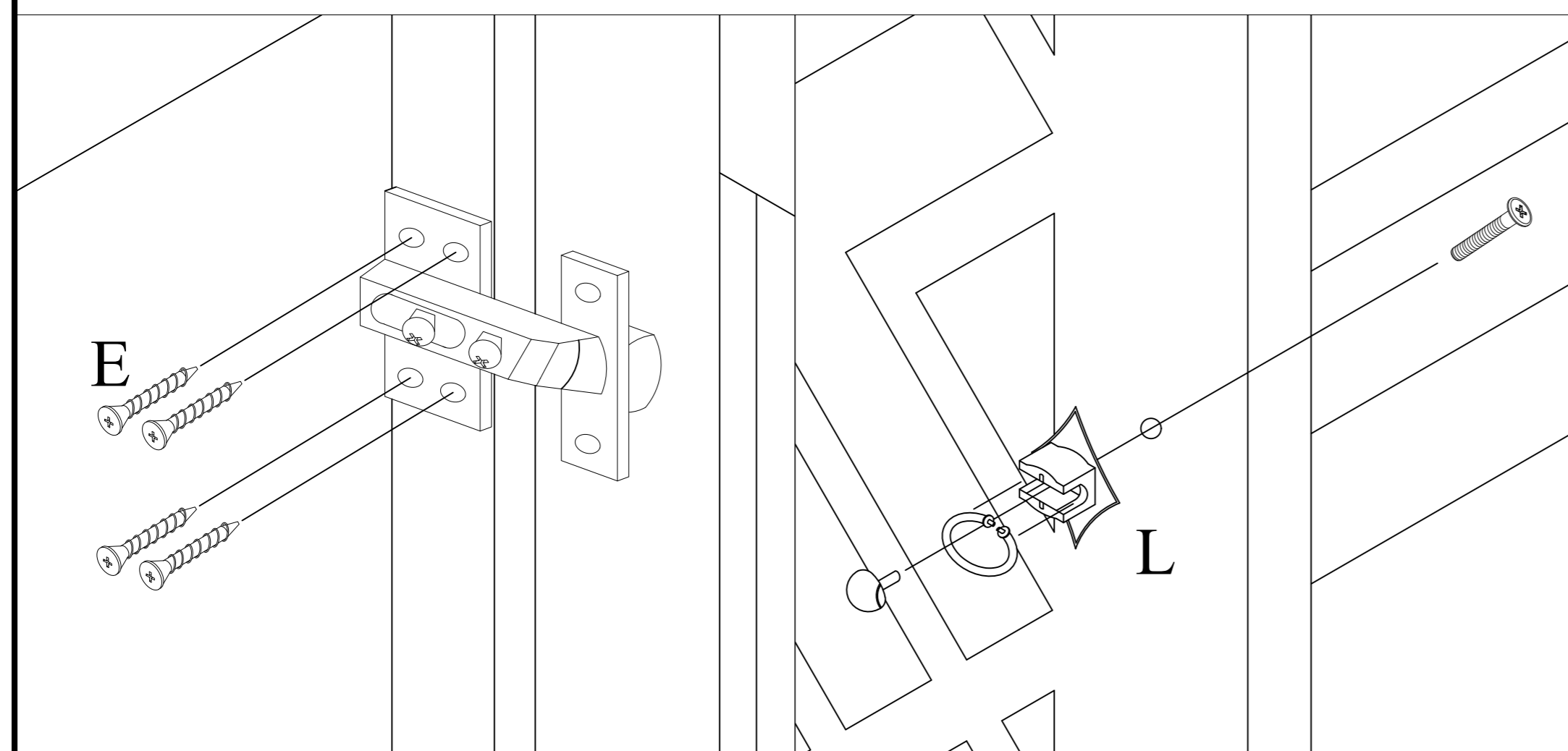
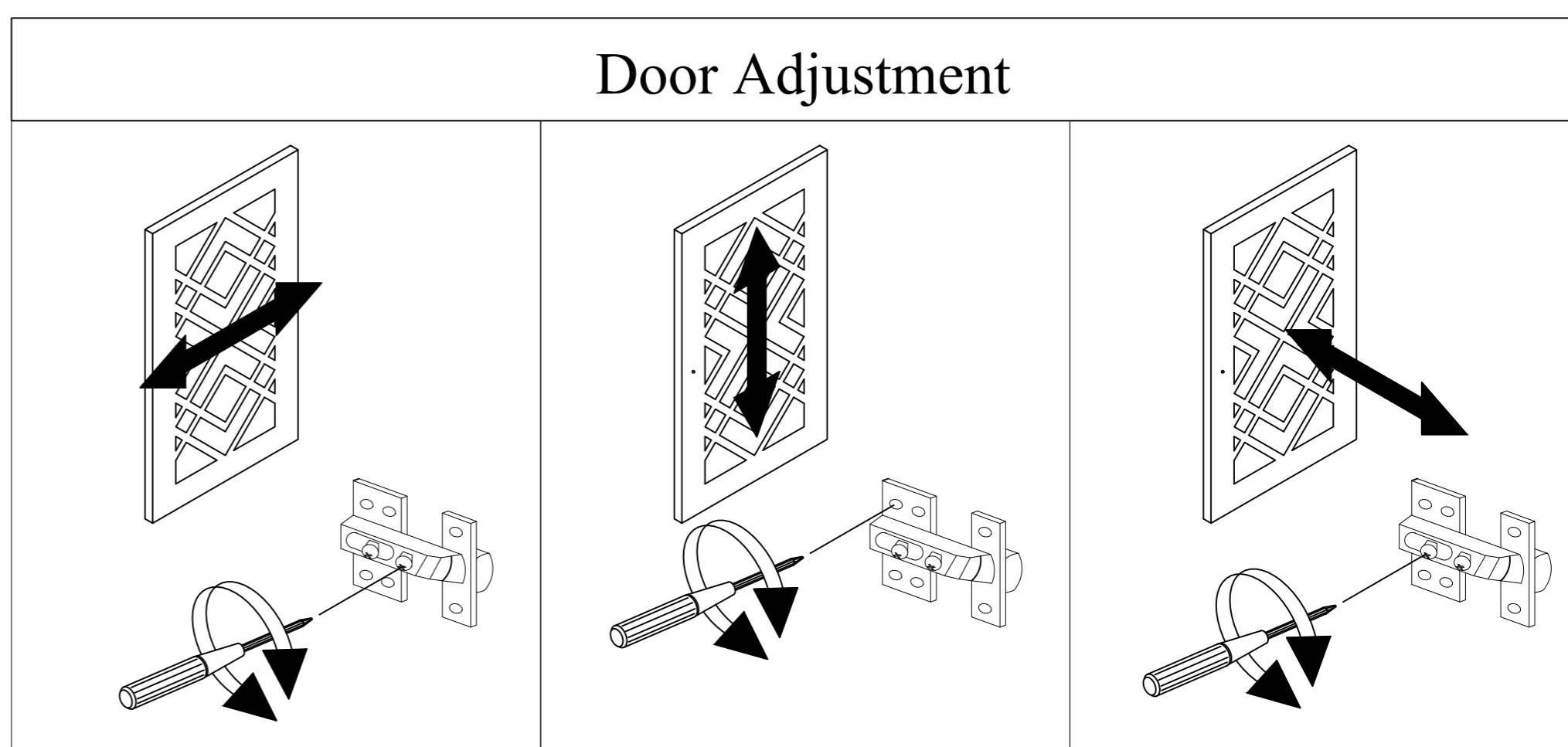
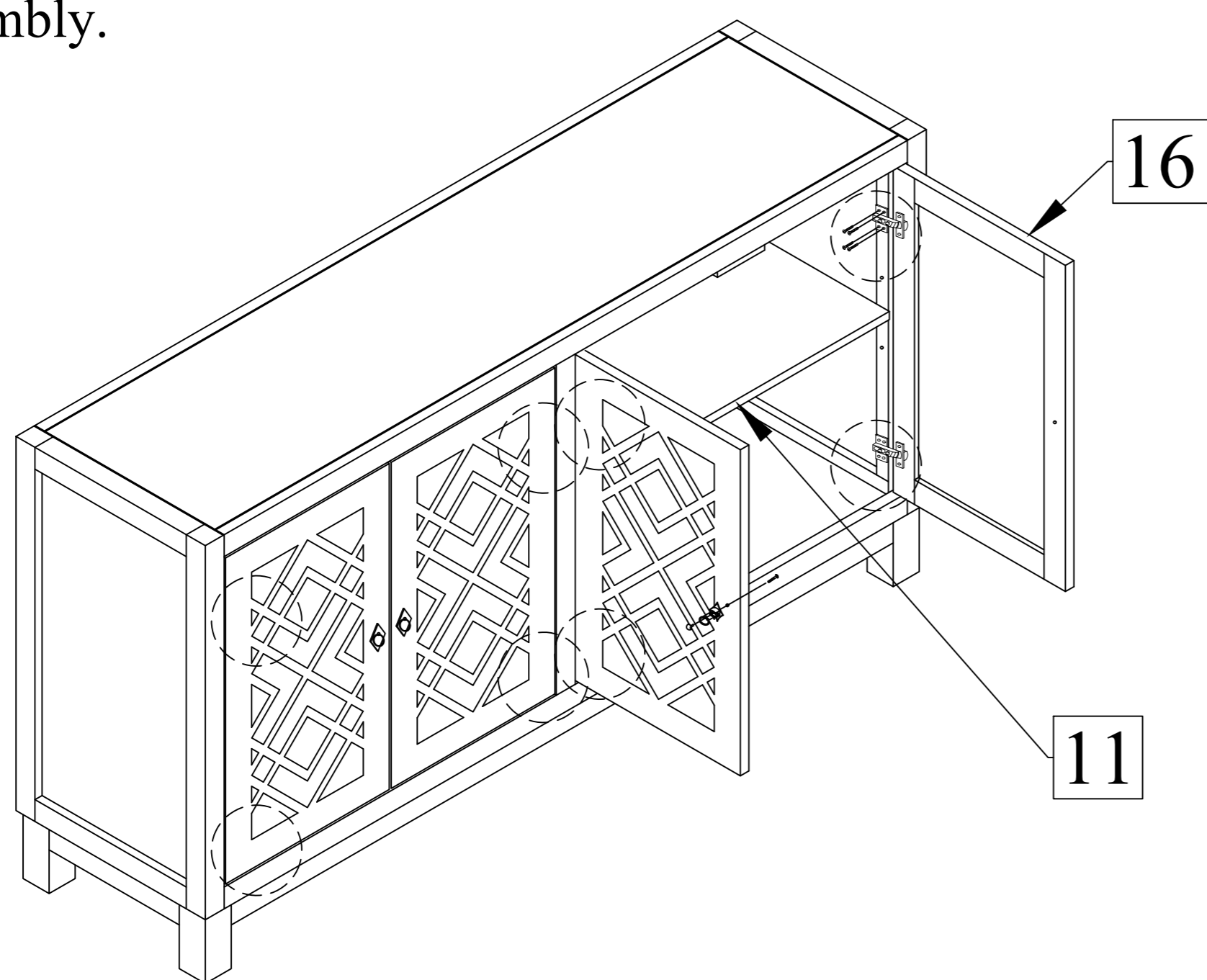

E	Screw M3.5 x 16MM		32PCS
L	Handle with Screw		4SETS