

ASSEMBLY INSTRUCTIONS

WF299347AAD PREVE TABLE

Read this instruction carefully. Refer hardware and furniture parts list for guidance. Be sure all parts are complete, before assembling. Place all wooden furniture part on a clean and flat soft surface to prevent scratches. Refer steps provided as assembling guide.

PART LIST				HARDWARE LIST		
ITEM	DESCRIPTION	QTY	ITEM	DESCRIPTION	QTY	
1	TABLE TOP	1 PC	A	JCBC SCREW M6 x 40MM	30 PCS	
2	TABLE LEG - L & R	4 PCS	B	SPRING WASHER 13MM	30 PCS	
3	CENTER STRETCHER RAIL	1 PC	C	FLAT WASHER 13MM	30 PCS	
4	LEG APRON SUPPORT	2 PCS	D	ALLEN KEY M4 (SHORT)	1 PC	
5	MOULDING PLATE	2 PCS				

CAUTIONS :

1. Do not **FULLY-TIGHTEN** the nuts or nut bolts until all are in place.
2. To prevent thread damage. Ensure that nuts or nut bolts are not over-tighten.
3. Hardware are to be kept out of reach from children.

STEP 1

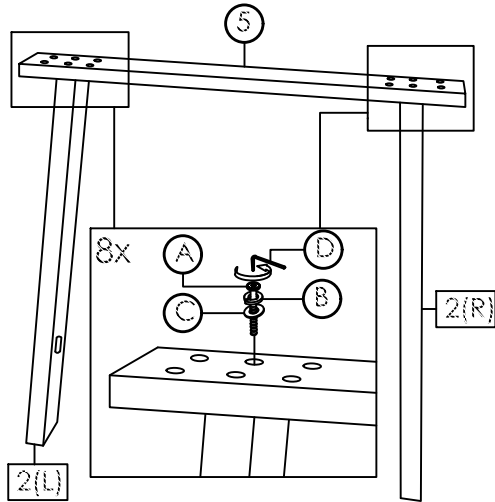

STEP 2

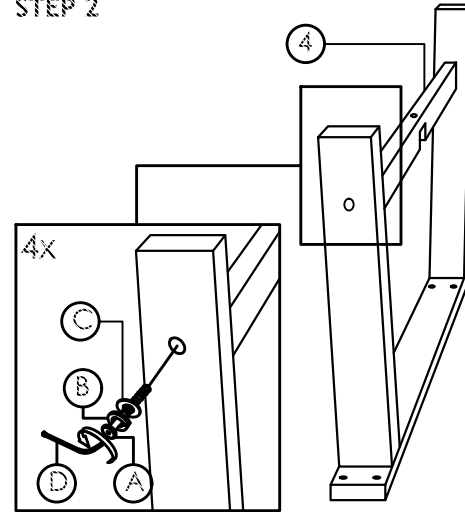

STEP 4

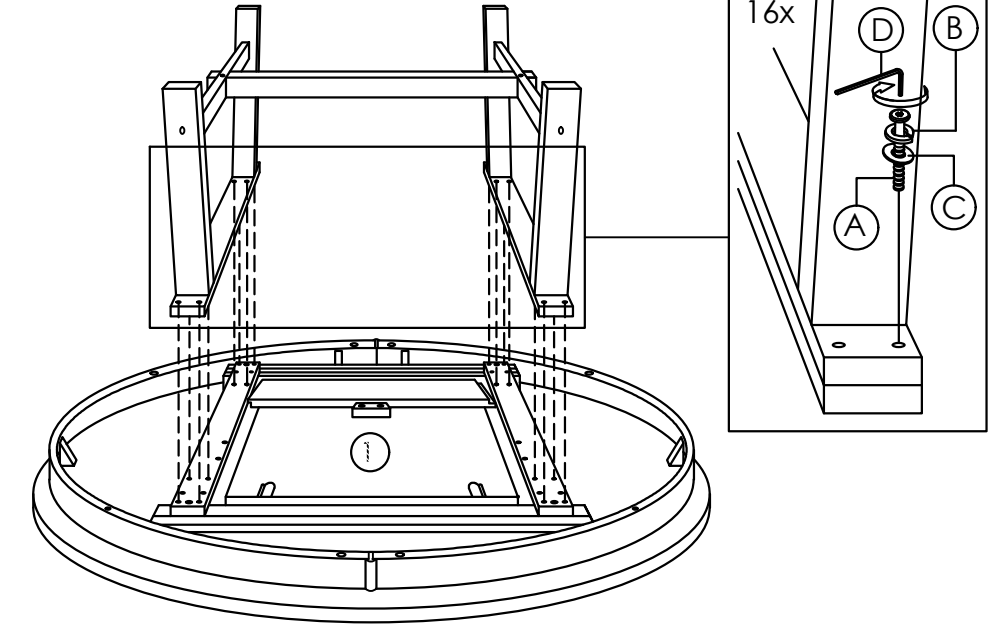

STEP 3

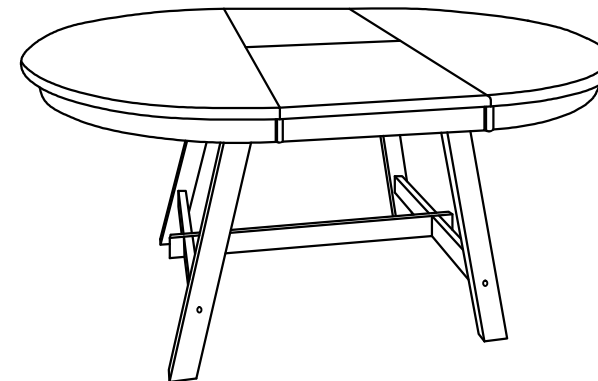
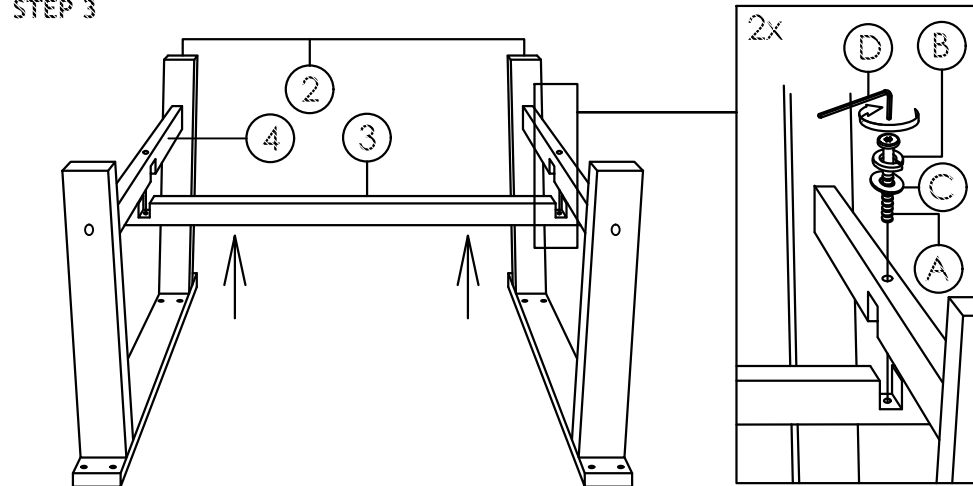

COMPLETED ASSEMBLY