

ASSEMBLY INSTRUCTIONS

WF295549 - DINING TABLE

IMPORTANT NOTE :



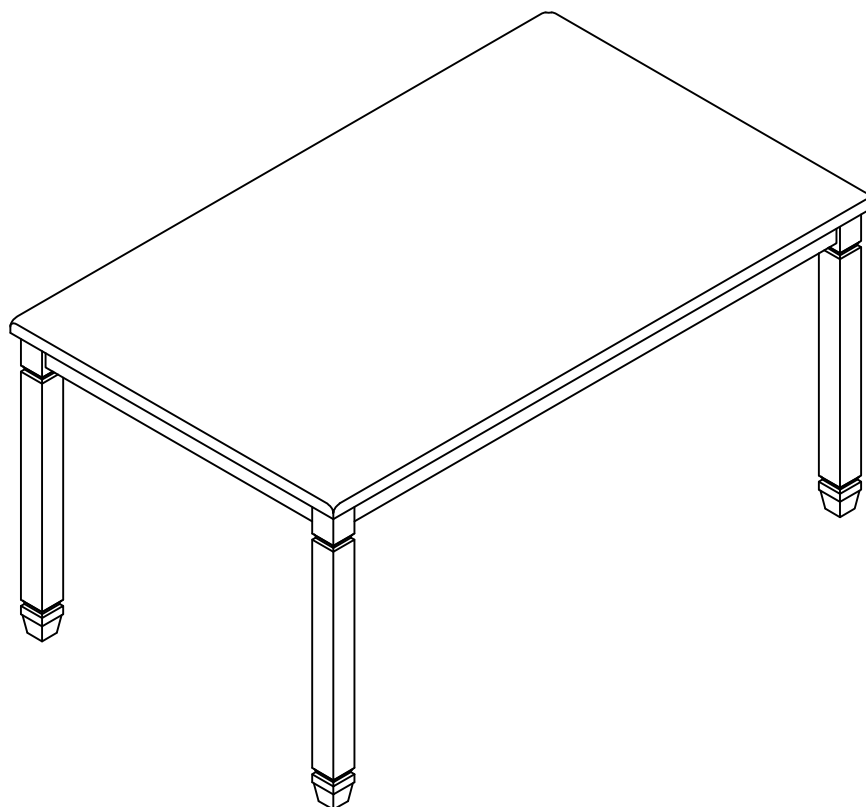

** PLACE ALL PARTS ON A CLEAN AND SMOOTH SURFACE SUCH AS A RUG OR CARPET TO AVOID THE PARTS FROM BEING SCRATCHED.

** BEFORE YOU BEGIN, KINDLY FOLLOW THE ASSEMBLY INSTRUCTIONS STEP BY STEP.

**DO NOT TIGHTEN ALL SCREWS AND BOLTS UNTIL THE CHAIR IS FULLY SET-UP.

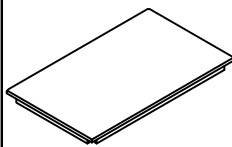

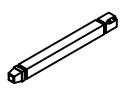
CARTONS ONLY ONE/ CARTONS SEULEMENT UN

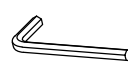
PART LISTS				HARDWARE LISTS			
NO.	DESCRIPTION	SKETCH	Q'TY	NO.	DESCRIPTION	SKETCH	Q'TY
1	TABLE TOP		1 PC	A	BOLT Ø5/16" x 70mmL		8 PCS
2	LEGS		4 PCS	B	SPRING WASHER Ø5/16" x 13mmL		8 PCS
				C	FLAT WASHER Ø5/16" x 19mmL		8 PCS
				D	ALLEN KEY		1 PC

ASSEMBLY INSTRUCTIONS

REMOVE MDF
CORNER SUPPORT

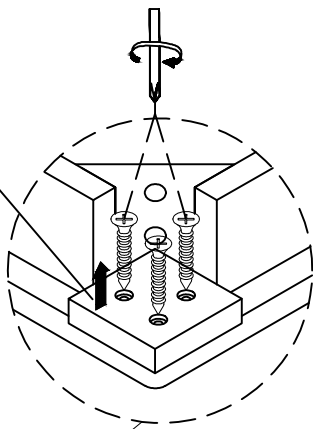

STEP 1:

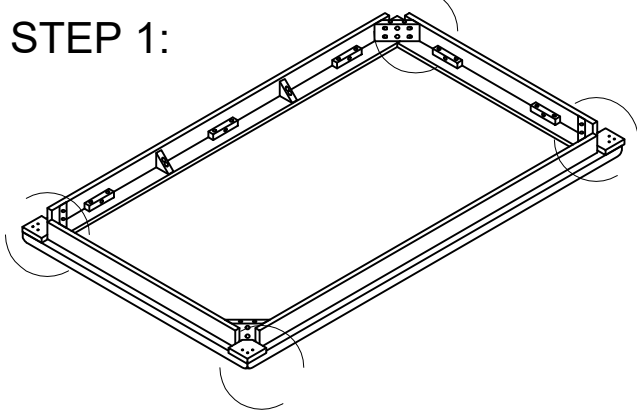

STEP 2:

