

# ASSEMBLY INSTRUCTIONS

## ITEM: WF294956AAK/AAP

Important note/ Note importante :

1. Place all wooden parts on a clean and smooth surface such as a rug or carpet to avoid scratching the parts.
2. Kindly follow the assembly instructions step by step.
3. Do not tighten all screws and bolts until the table is fully assembled.
4. Unscrew the protective plastic supports from the metal insert of the table legs before assembly.

### PARTS IDENTIFICATION

( A ) Chair Back

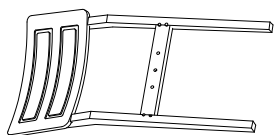

1 pc

( B ) Seat Frame

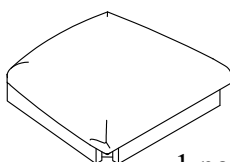

1 pc

( C ) Front Leg

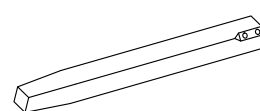

2 pcs

### HARDWARE IDENTIFICATION

( 1 ) Bolt  
(1/4"x80mm)



( 4pcs )

( 2 ) Bolt  
(1/4"x60mm)



( 4pcs )

( 3 ) Bolt  
(1/4"x38mm)



( 2pcs )

( 4 ) Spring Washer  
(1/4"x11mm)



( 10pcs )

( 5 ) Flat Washer  
(1/4"x16mm)



( 10pcs )

( 6 ) Allen Key



( 1pc )

#### STEP 1

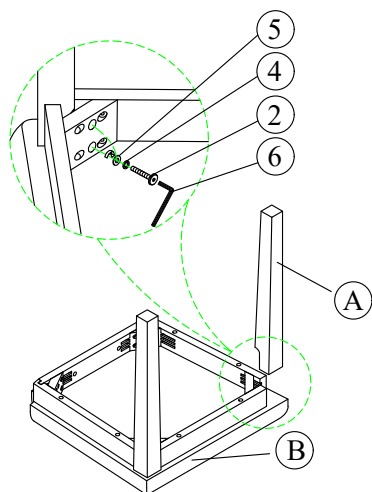

#### STEP 2

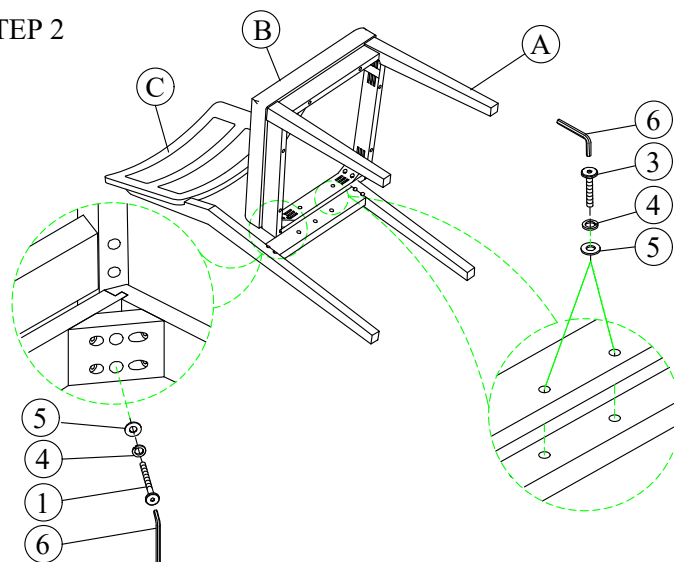

COMPLETE

