

# ASSEMBLY INSTRUCTIONS

ITEM NO.WF290973

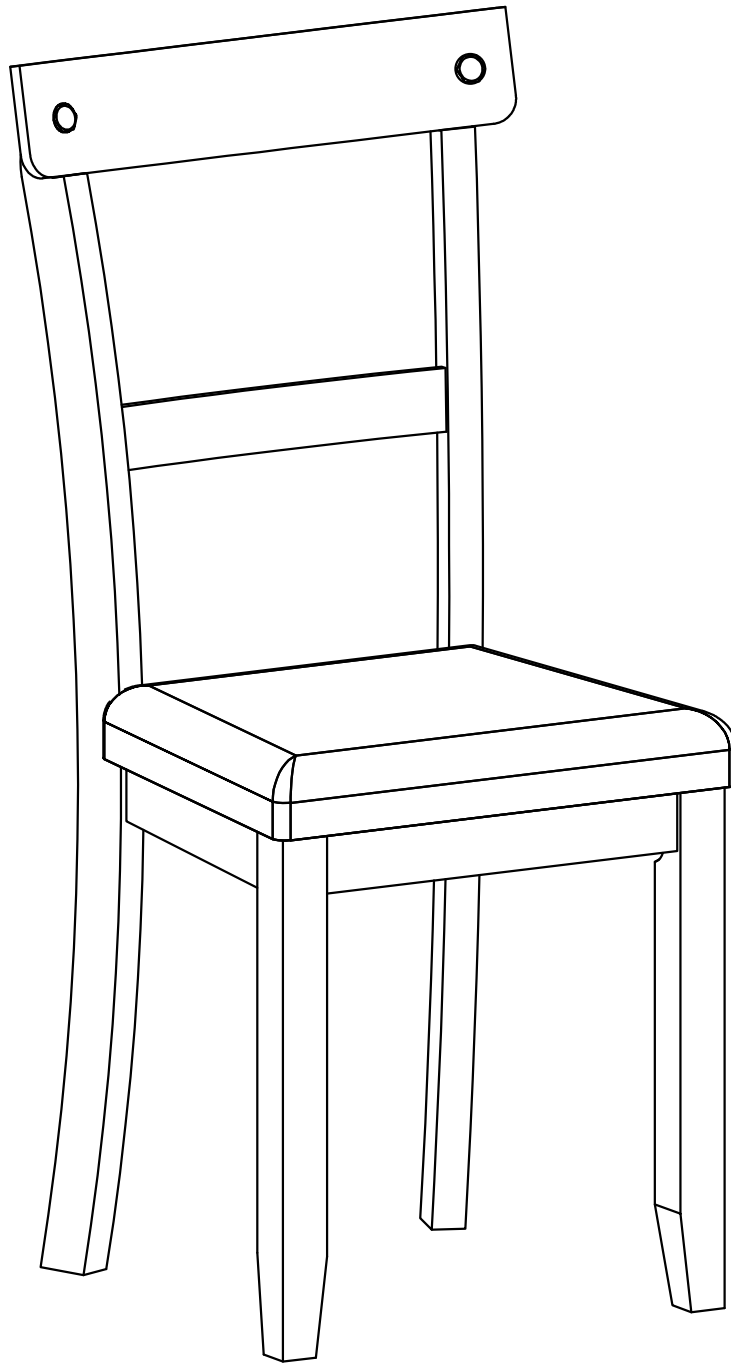



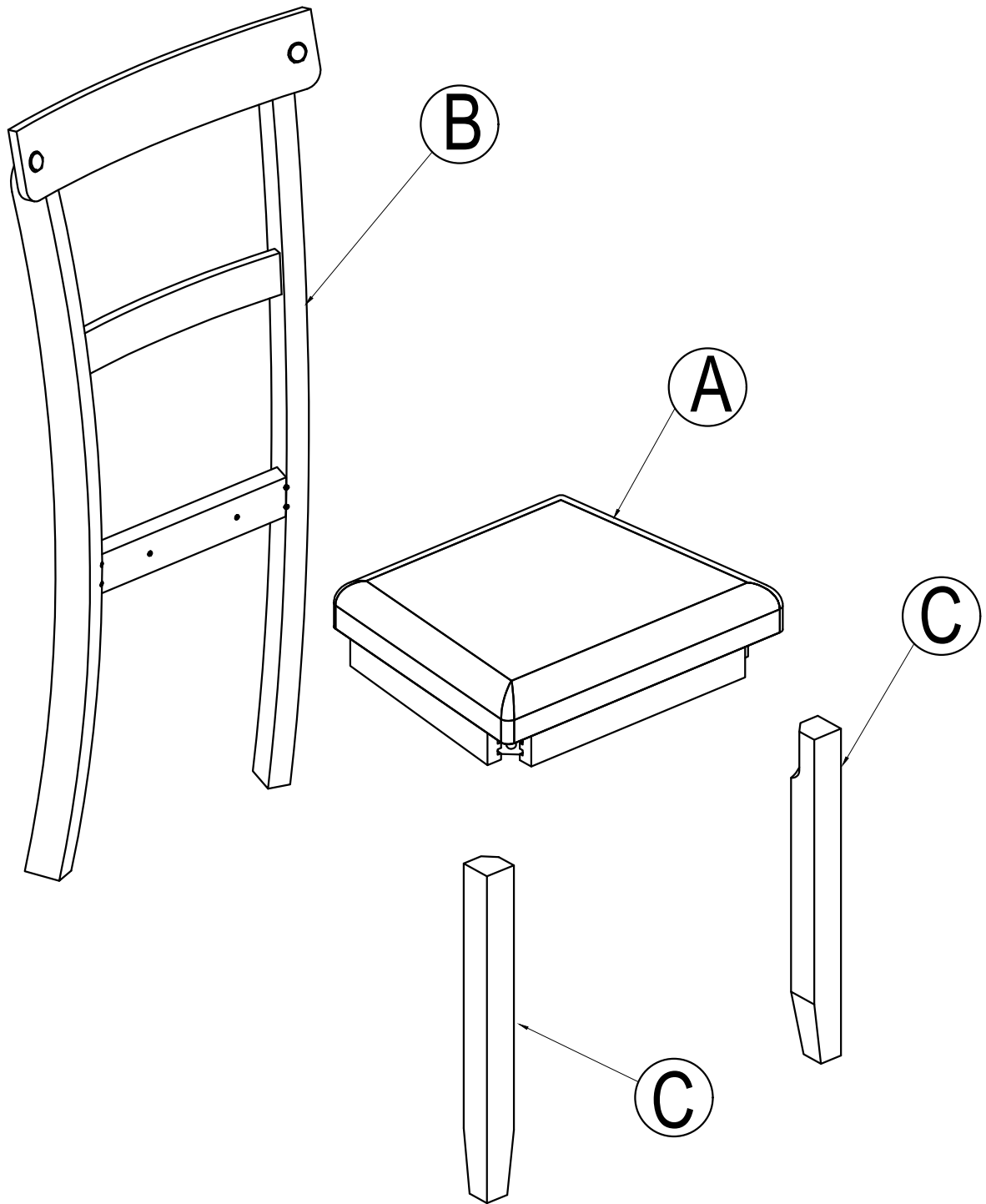

## IMPORTANT NOTE :

- ① PLACE ALL PARTS ON A CLEAN AND SMOOTH SURFACE SUCH AS A RUG OR CARPET TO AVOID THE PARTS FROM BEING SCRATCHED.
- ② BEFORE YOU BEGIN,KINDLY FOLLOW THE ASSEMBLY INSTRUCTIONS STEP BY STEP.
- ③ DO NOT TIGHTEN ALL SCREWS AND BOLTS UNTIL THE CHAIR IS FULLY SET-UP.

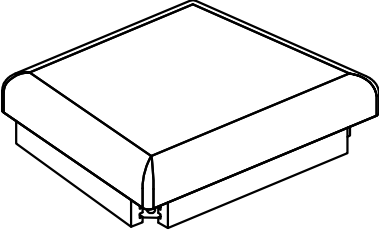
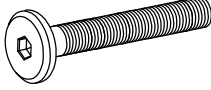
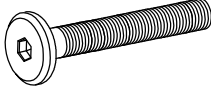
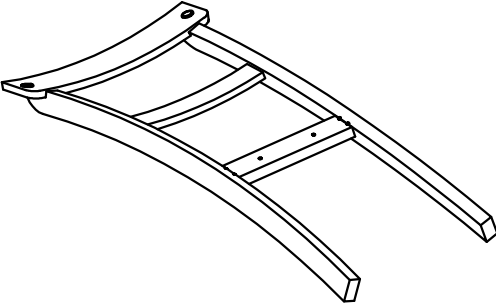
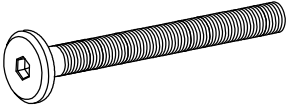

# Part List

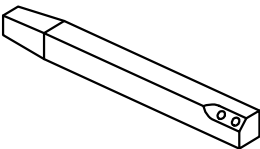
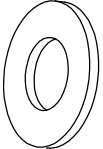
# Hardware List

<p><b>(A)</b></p>  <p>CUSHION SEAT (4PCS)</p>	<p><b>(1)</b></p>  <p>Ø 1/4" x 40mm</p>
	<p>BOLT (8pcs)</p>
	<p><b>(2)</b></p>  <p>Ø 1/4" x 55mm</p>
	<p>BOLT (16pcs)</p>
<p><b>(B)</b></p>  <p>CHAIR BACK (4PCS)</p>	<p><b>(3)</b></p>  <p>Ø 1/4" x 75mm</p>
	<p>BOLT (16pcs)</p>
	<p><b>(4)</b></p>  <p>Ø5/16" x 13mm</p>
	<p>FLAT WASHER (40pcs)</p>
<p><b>(C)</b></p>  <p>FRONT LEGS (8PCS)</p>	<p><b>(5)</b></p>  <p>Ø5/16" x 19mm</p>
	<p>LOCK WASHER (40pcs)</p>
	<p><b>(6)</b></p>  <p>4mm</p>
	<p>ALLEN KEY (1pc)</p>

# STEP 1:

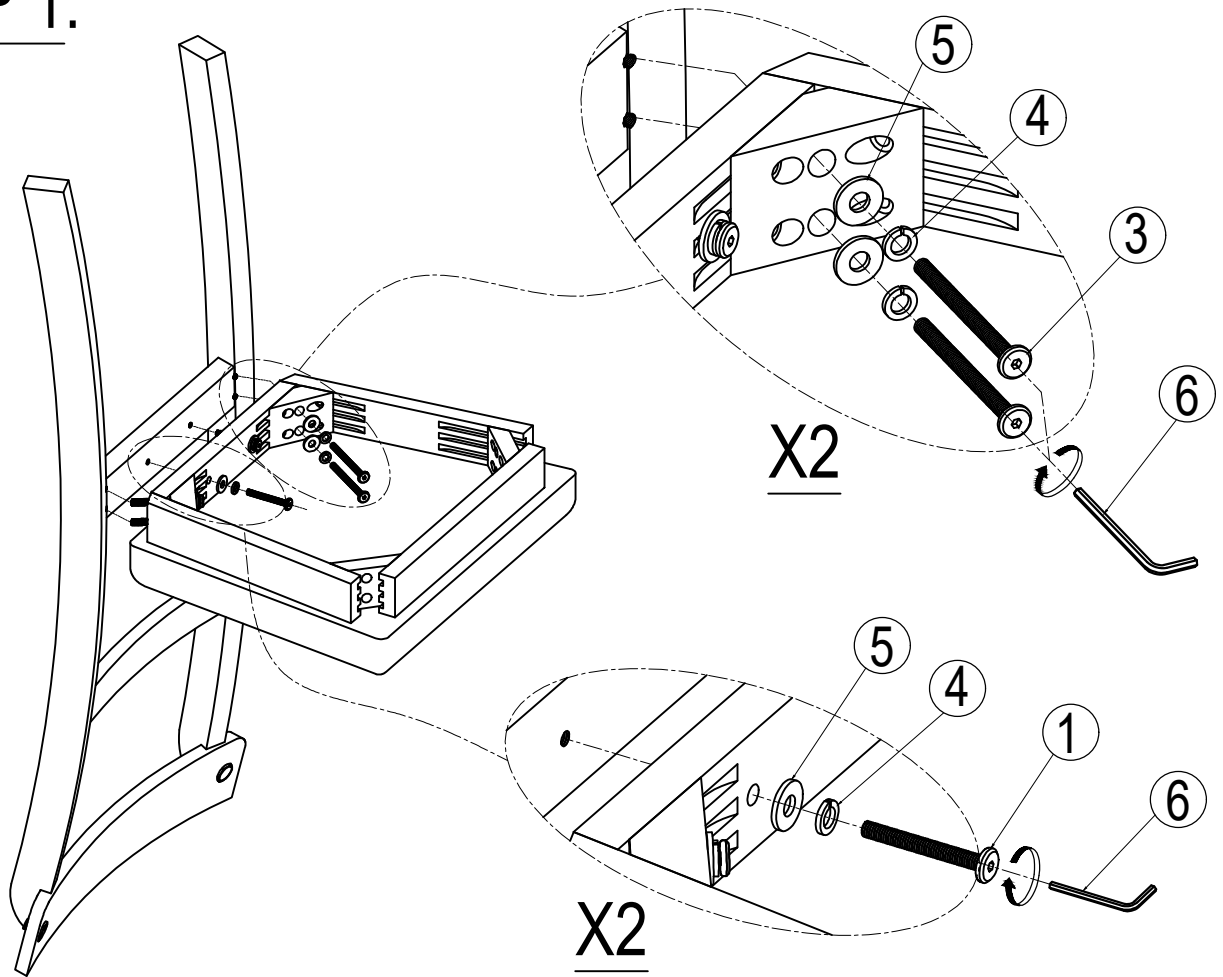

# STEP 2:

