

# ASSEMBLY INSTRUCTIONS

ITEM NO.WF289811

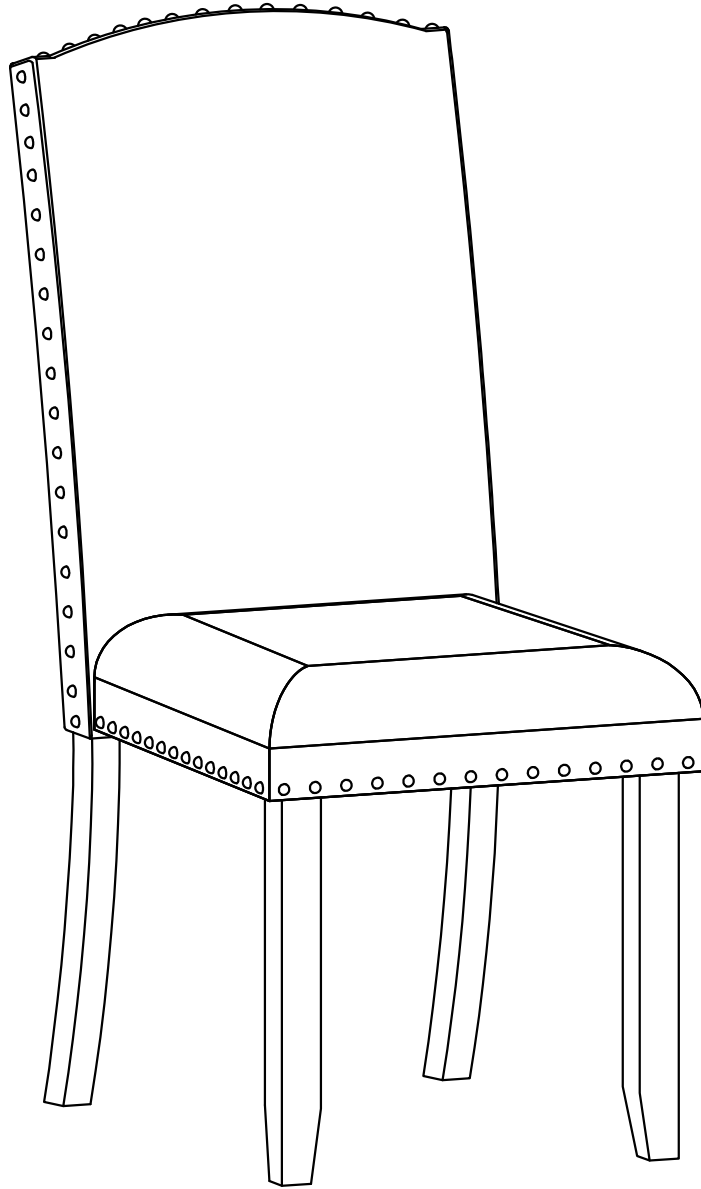

## IMPORTANT NOTE :

- ① PLACE ALL PARTS ON A CLEAN AND SMOOTH SURFACE SUCH AS A RUG OR CARPET TO AVOID THE PARTS FROM BEING SCRATCHED.
- ② BEFORE YOU BEGIN,KINDLY FOLLOW THE ASSEMBLY INSTRUCTIONS STEP BY STEP.
- ③ DO NOT TIGHTEN ALL SCREWS AND BOLTS UNTIL THE CHAIR IS FULLY SET-UP.

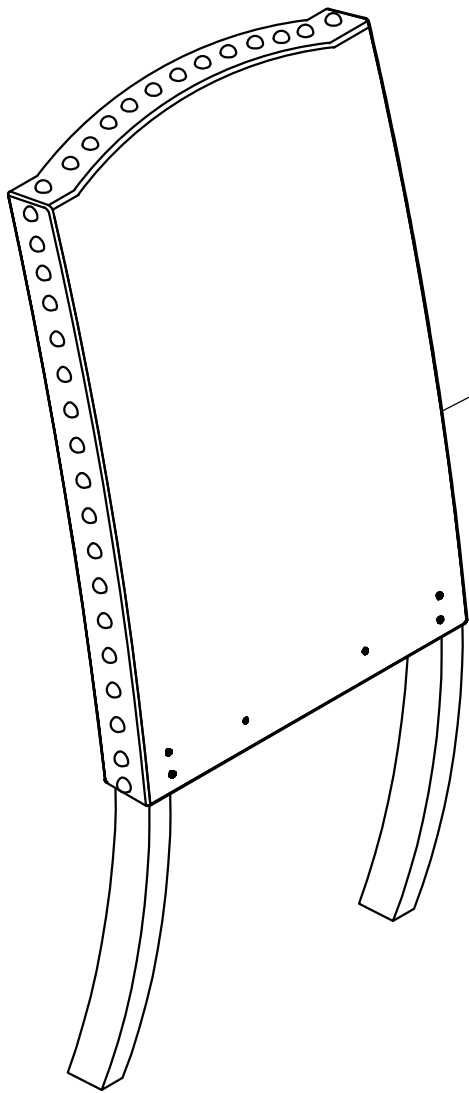

**B**

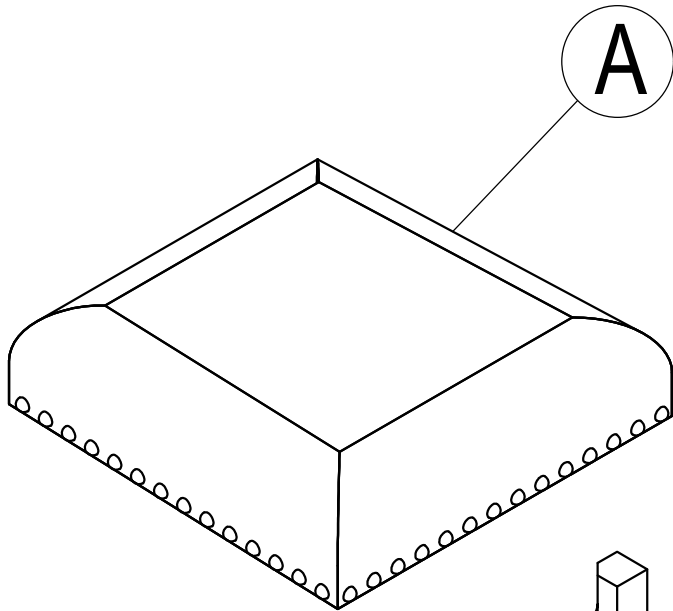

**A**

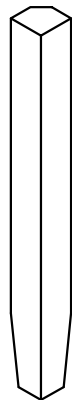

**C**

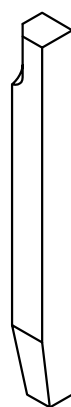

**C**

# Part List

# Hardware List

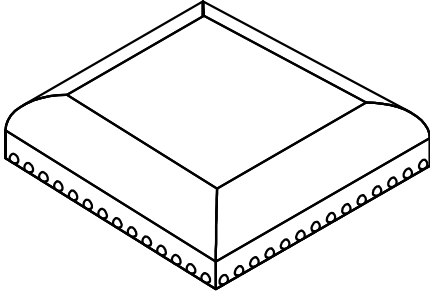
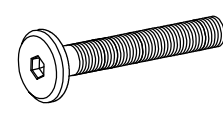
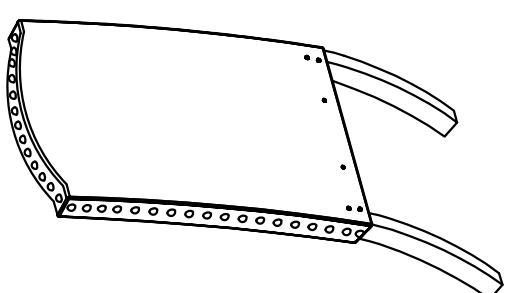
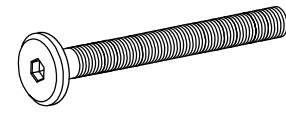
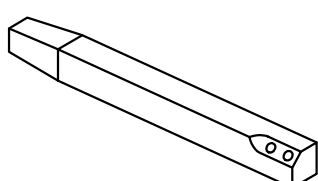
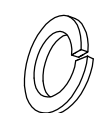
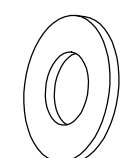
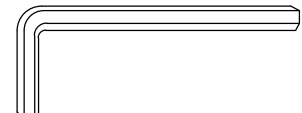
<p>(A)</p> 	<p>(1)</p>  <p>Ø 1/4" x 45mm</p>
<p>SEAT CHAIR (4pcs)</p>	<p>BOLT (24pcs)</p>
<p>(B)</p> 	<p>(2)</p>  <p>Ø 1/4" x 75mm</p>
<p>BACK CHAIR (4pcs)</p>	<p>BOLT (16pcs)</p>
<p>(C)</p> 	<p>(3)</p>  <p>Ø5/16" x 13mm</p>
<p>LEG FRONT (8pcs)</p>	<p>FLAT WASHER (40pcs)</p>
	<p>(4)</p>  <p>Ø5/16" x 19mm</p>
	<p>LOCK WASHER (40pcs)</p>
	<p>(5)</p>  <p>4mm</p>
	<p>ALLEN KEY (1pc)</p>

# STEP 1

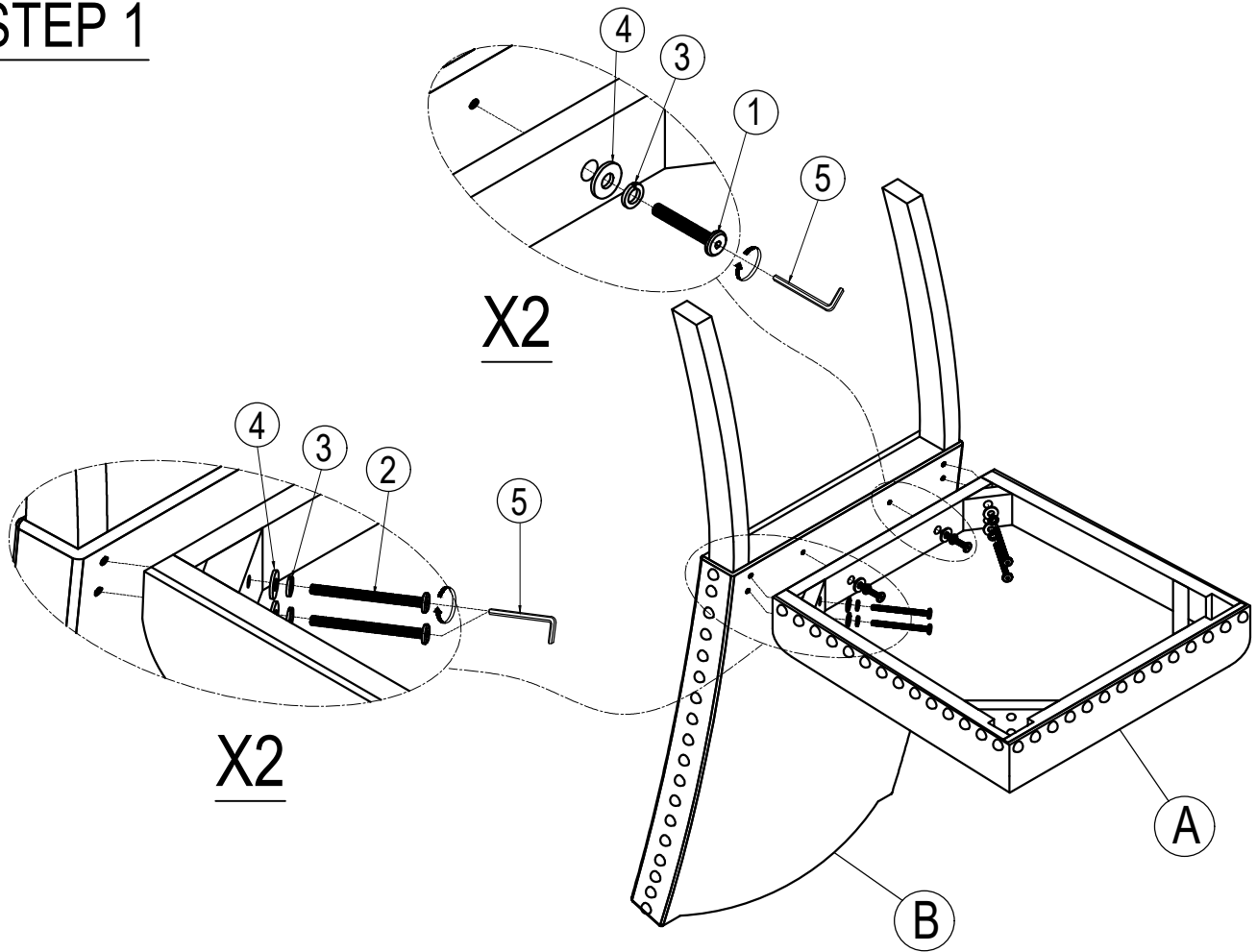

# STEP 2

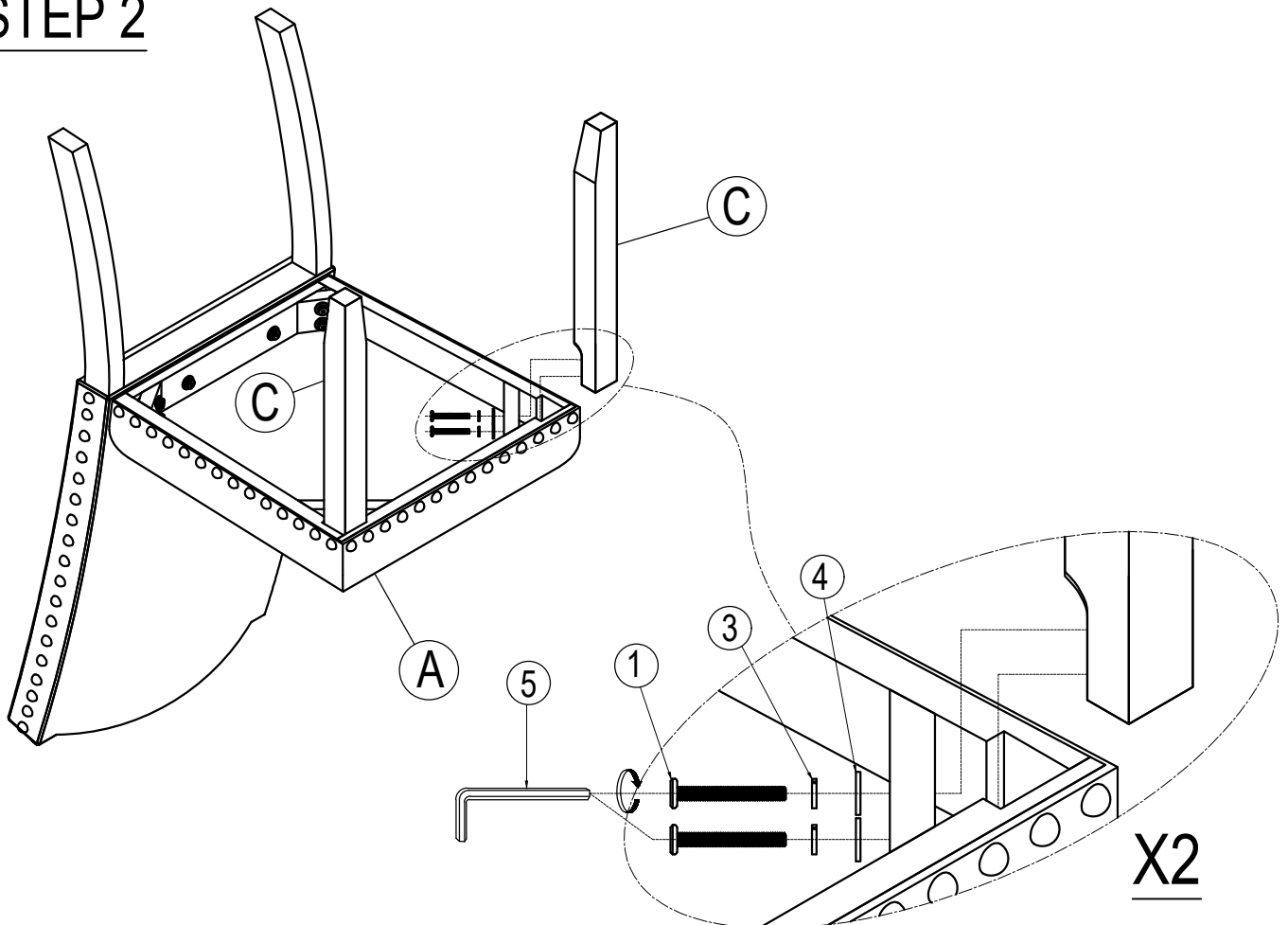

# ASSEMBLY INSTRUCTIONS

ITEM NO.WF289811

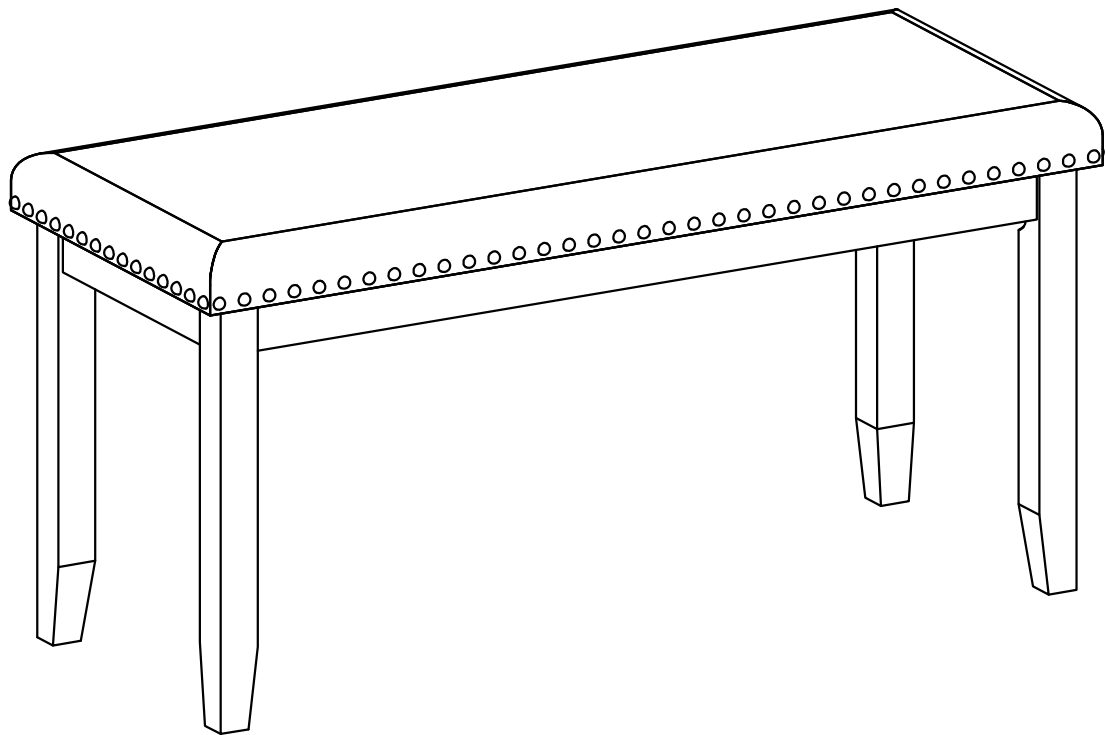



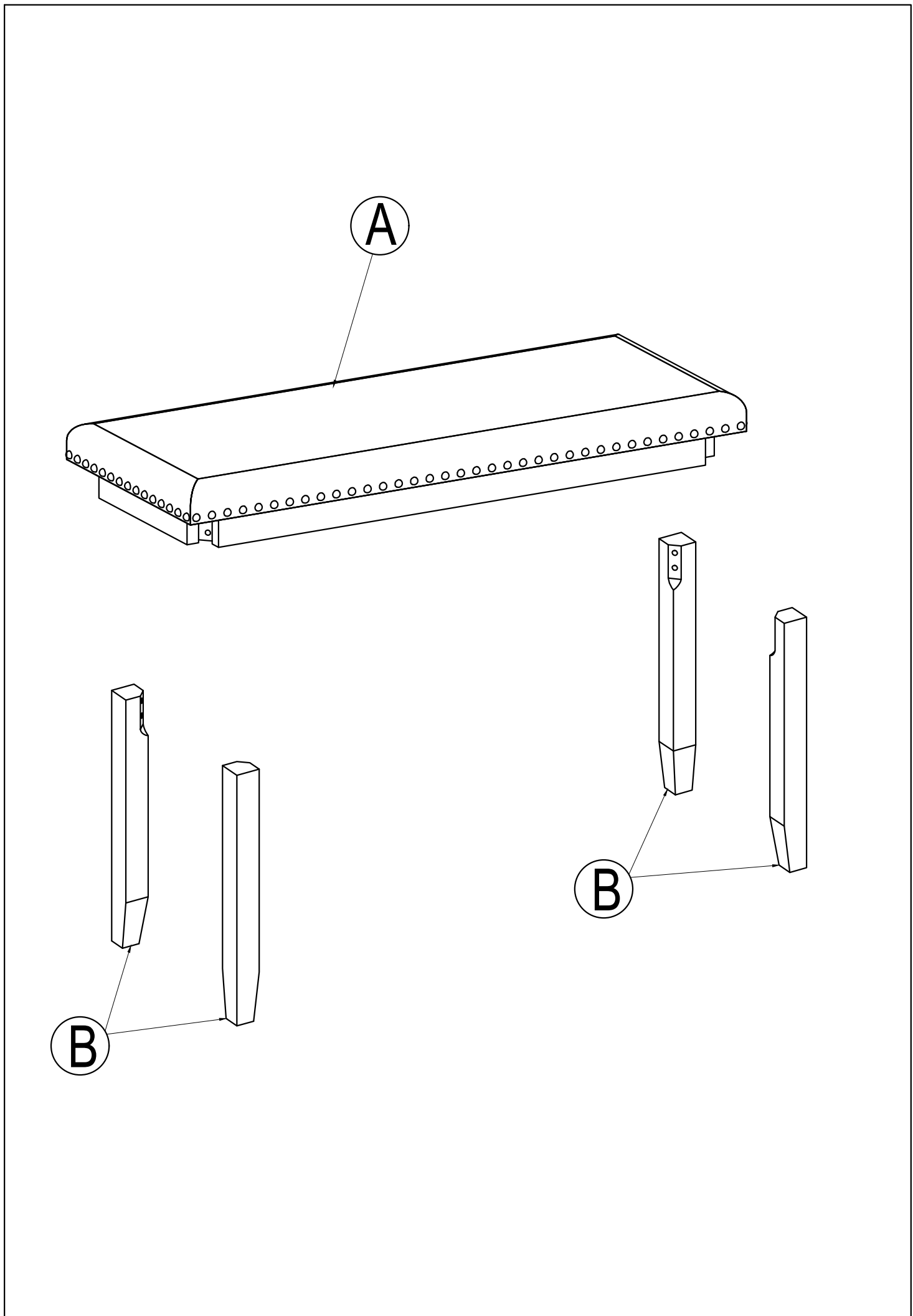

## IMPORTANT NOTE :

- ① PLACE ALL PARTS ON A CLEAN AND SMOOTH SURFACE SUCH AS A RUG OR CARPET TO AVOID THE PARTS FROM BEING SCRATCHED.
- ② BEFORE YOU BEGIN,KINDLY FOLLOW THE ASSEMBLY INSTRUCTIONS STEP BY STEP.
- ③ DO NOT TIGHTEN ALL SCREWS AND BOLTS UNTIL THE BENCH IS FULLY SET-UP.

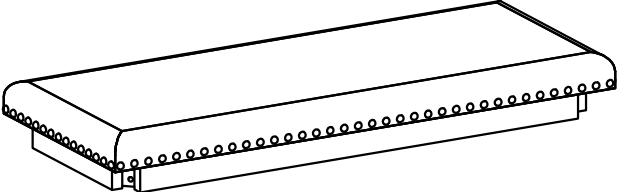
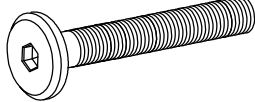

# Part List

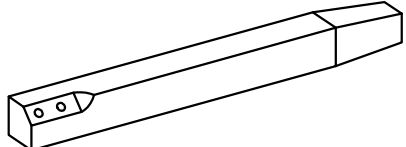
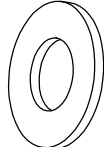
# Hardware List

<p>Ⓐ</p>  <p>BENCH CUSHION SEAT (1 pc)</p>	<p>①</p>  <p>Ø1/4" x 50 mm</p> <p>BOLT (8 pcs)</p>
	<p>②</p>  <p>Ø5/16" x 13 mm</p> <p>FLAT WASHER (8 pcs)</p>
<p>Ⓑ</p>  <p>BENCH LEG (4 pcs)</p>	<p>③</p>  <p>Ø5/16" x 19 mm</p> <p>LOCK WASHER (8 pcs)</p>
	<p>④</p>  <p># 4 x 38 mm</p> <p>ALLEN KEY (1 pc)</p>

# STEP 1:

