

ASSEMBLY INSTRUCTIONS

ITEM NO.WF290169

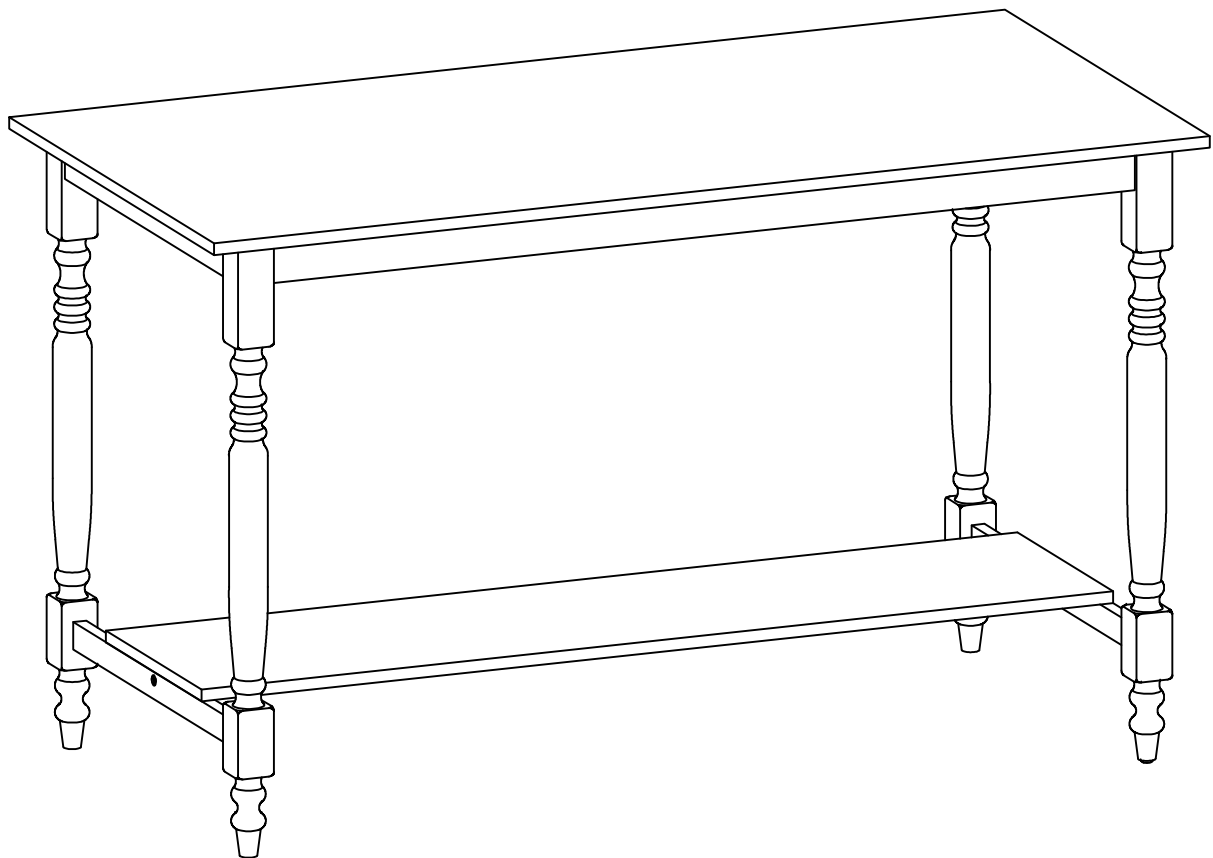



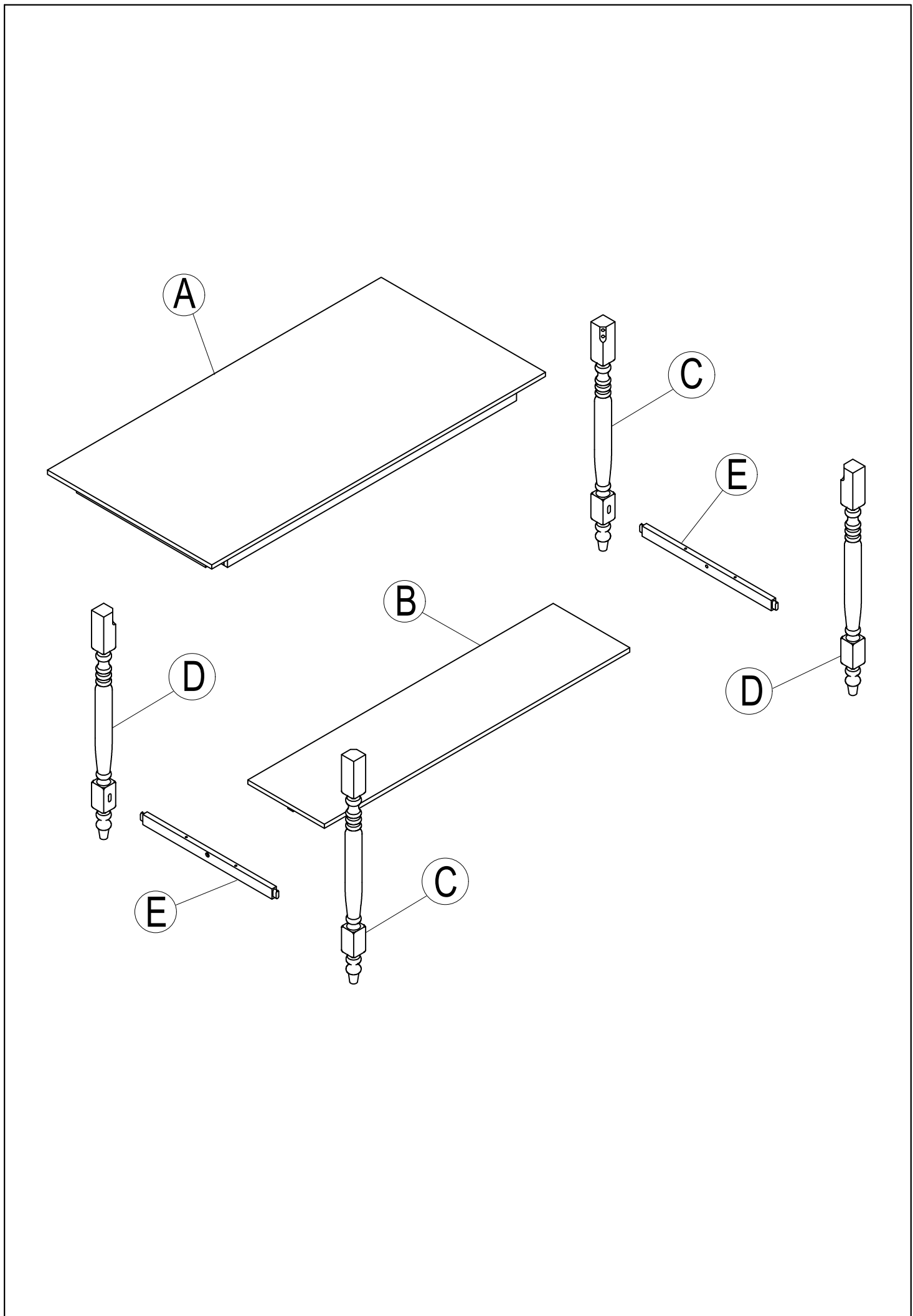

IMPORTANT NOTE :

- ① PLACE ALL PARTS ON A CLEAN AND SMOOTH SURFACE SUCH AS A RUG OR CARPET TO AVOID THE PARTS FROM BEING SCRATCHED.
- ② BEFORE YOU BEGIN,KINDLY FOLLOW THE ASSEMBLY INSTRUCTIONS STEP BY STEP.
- ③ DO NOT TIGHTEN ALL SCREWS AND BOLTS UNTIL THE TABLE IS FULLY SET-UP.

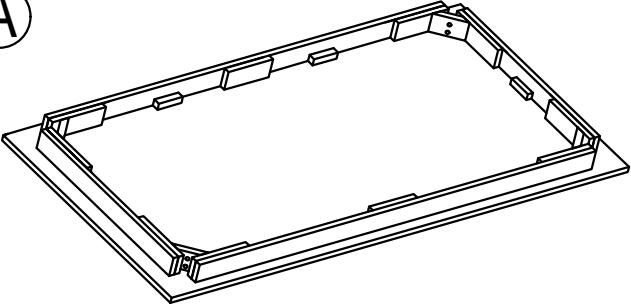
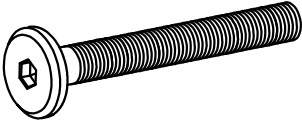
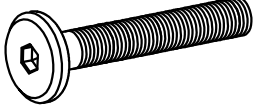
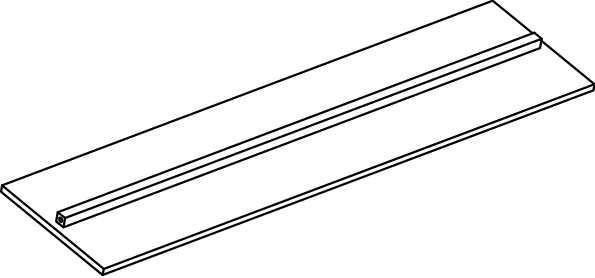

Part List

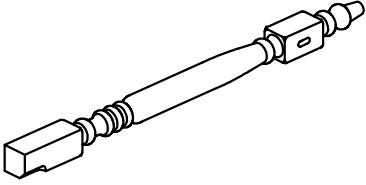
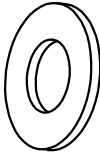
Hardware List

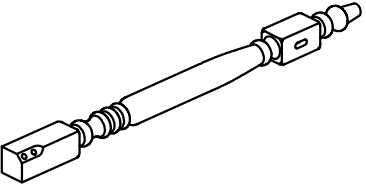
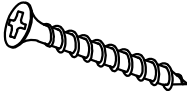
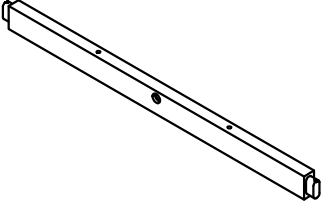
<p>(A)</p> 	<p>1</p>  <p>Ø 5/16" x 55 mm BOLT (8 pcs)</p>
<p>TOP TABLE (1 pc)</p>	<p>2</p>  <p>Ø 1/4" x 30 mm BOLT (2 pcs)</p>
<p>(B)</p> 	<p>3</p>  <p>Ø5/16" x 13 mm FLAT WASHER (8 pcs)</p>
<p>(C)</p> 	<p>4</p>  <p>Ø5/16" x 19 mm LOCK WASHER (8 pcs)</p>
<p>LEG LEFT (2 pcs)</p>	<p>5</p>  <p>4 mm ALLEN KEY (1 pc)</p>
<p>(D)</p> 	<p>6</p>  <p>Ø4 x 38 mm WOOD SCREWS (8 pcs)</p>
<p>(E)</p> 	<p>STRETCHER (2 pcs)</p>

STEP 1:

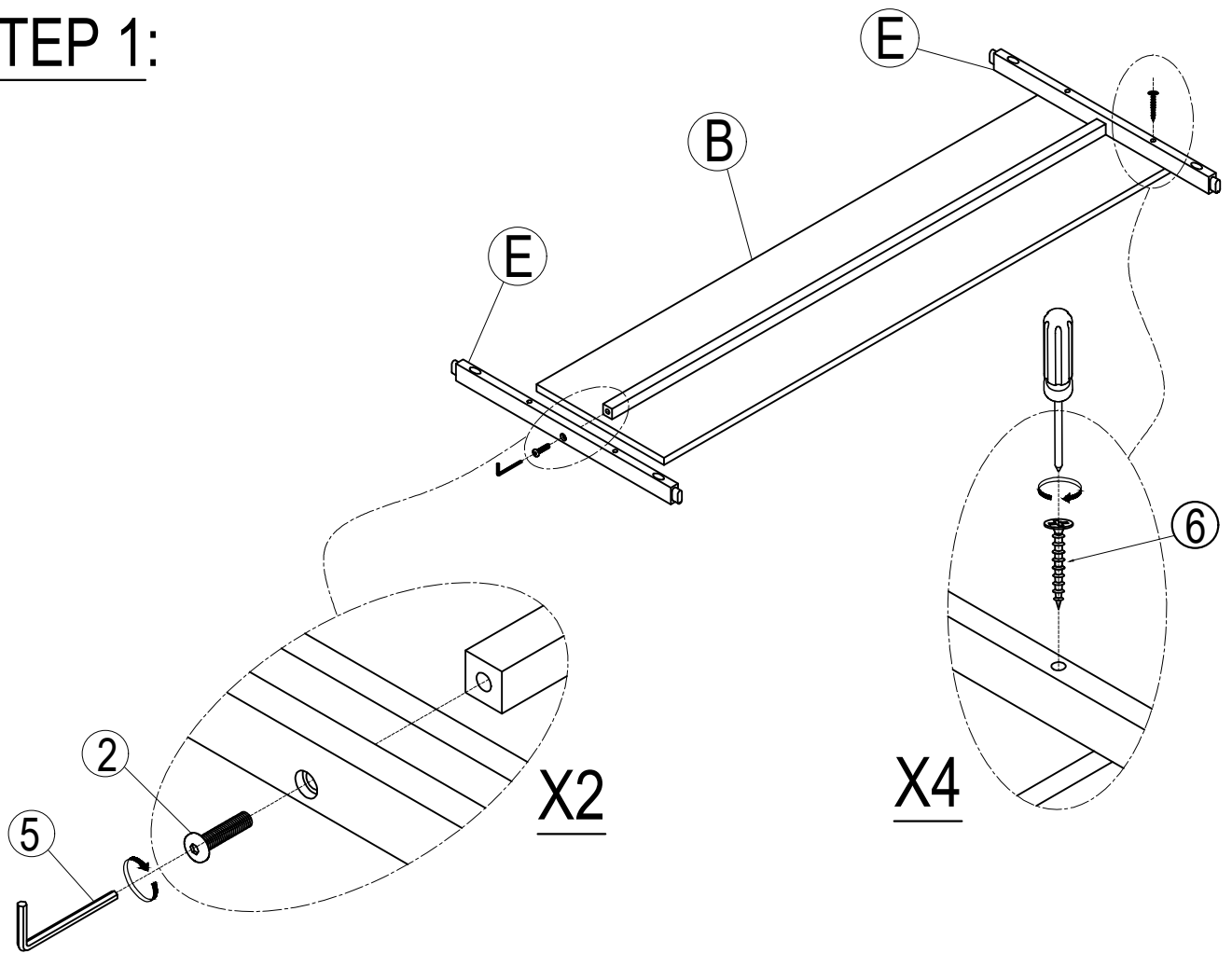

STEP 2:

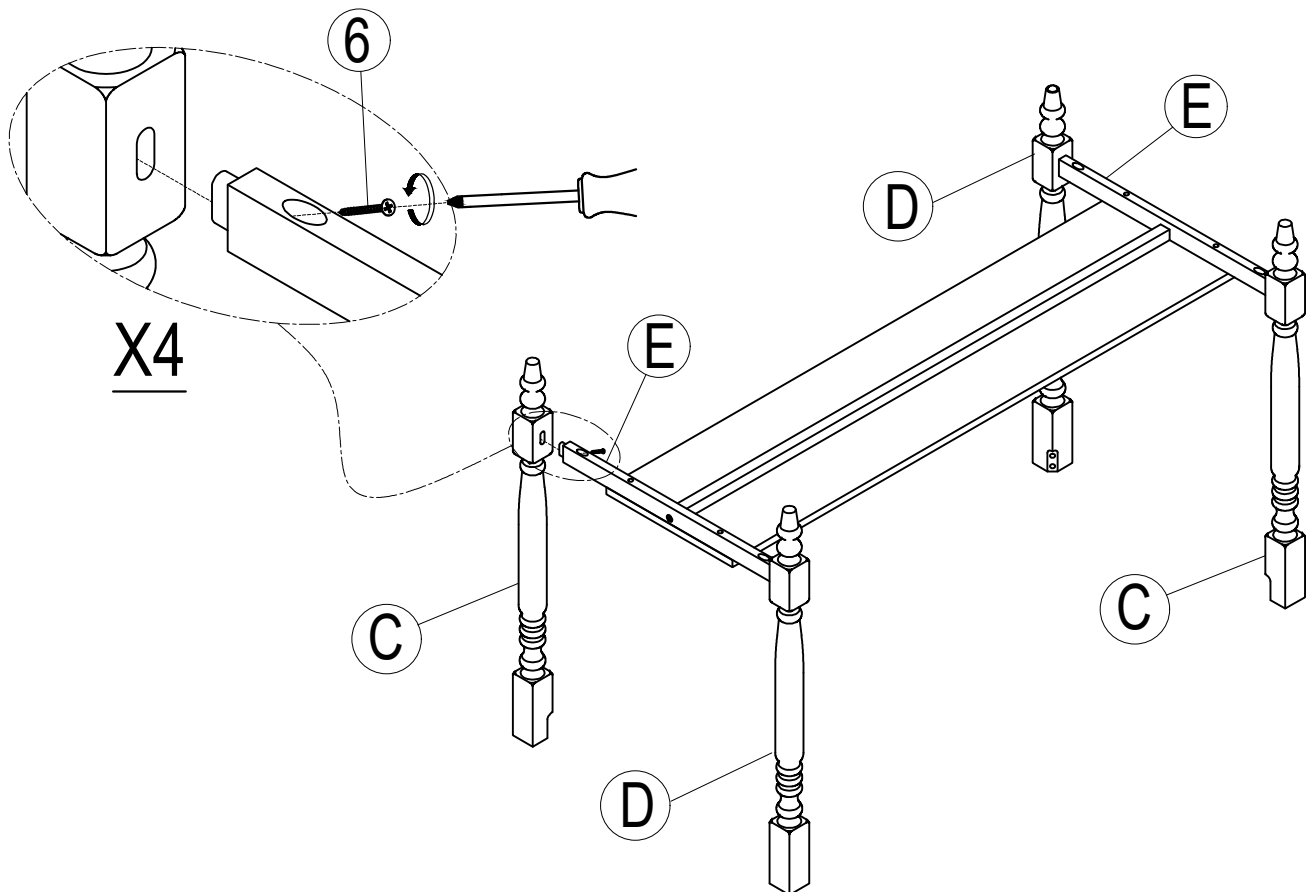

STEP 3:

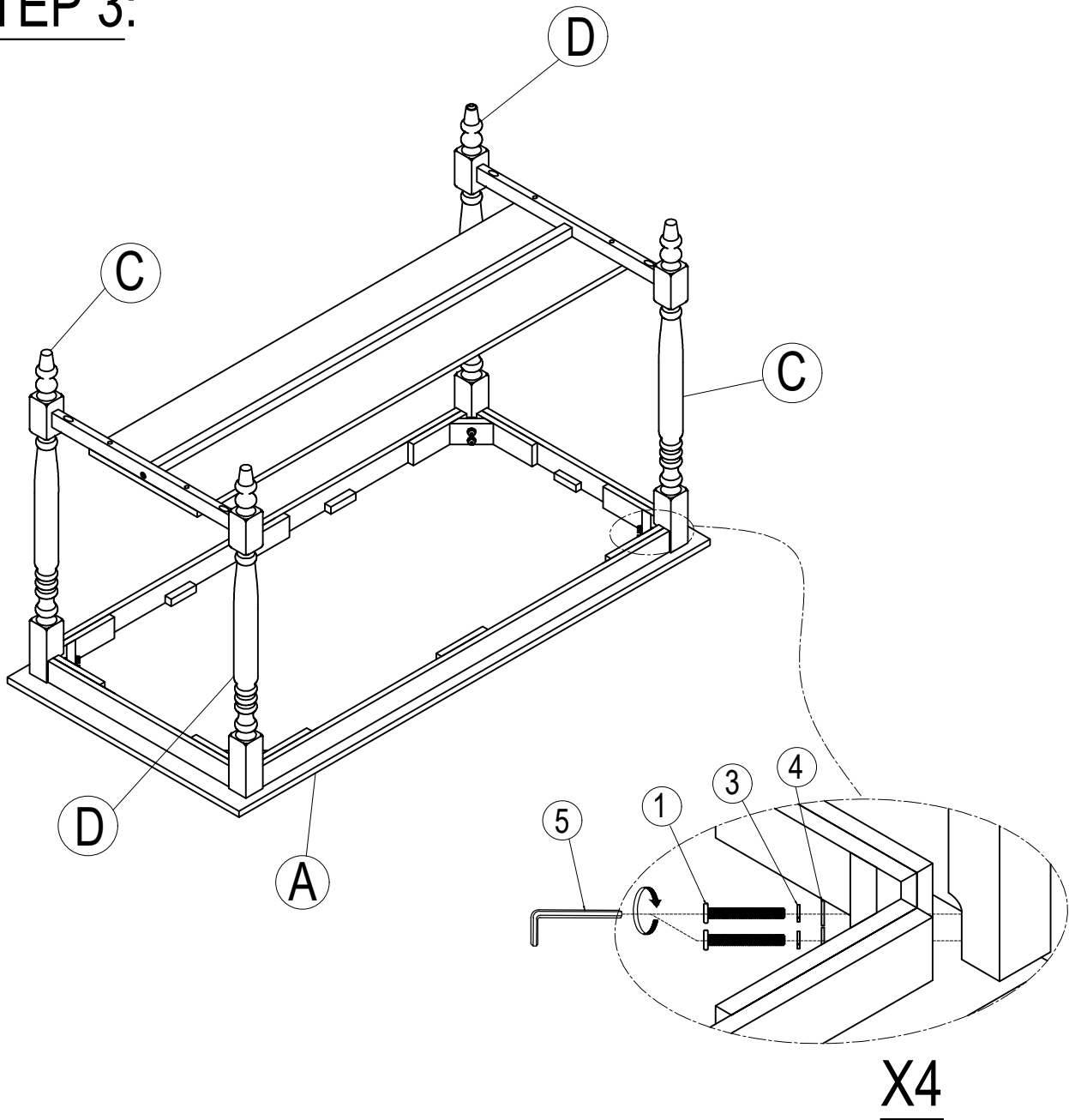

X4