

ASSEMBLY INSTRUCTIONS

ITEM NO.WF283866

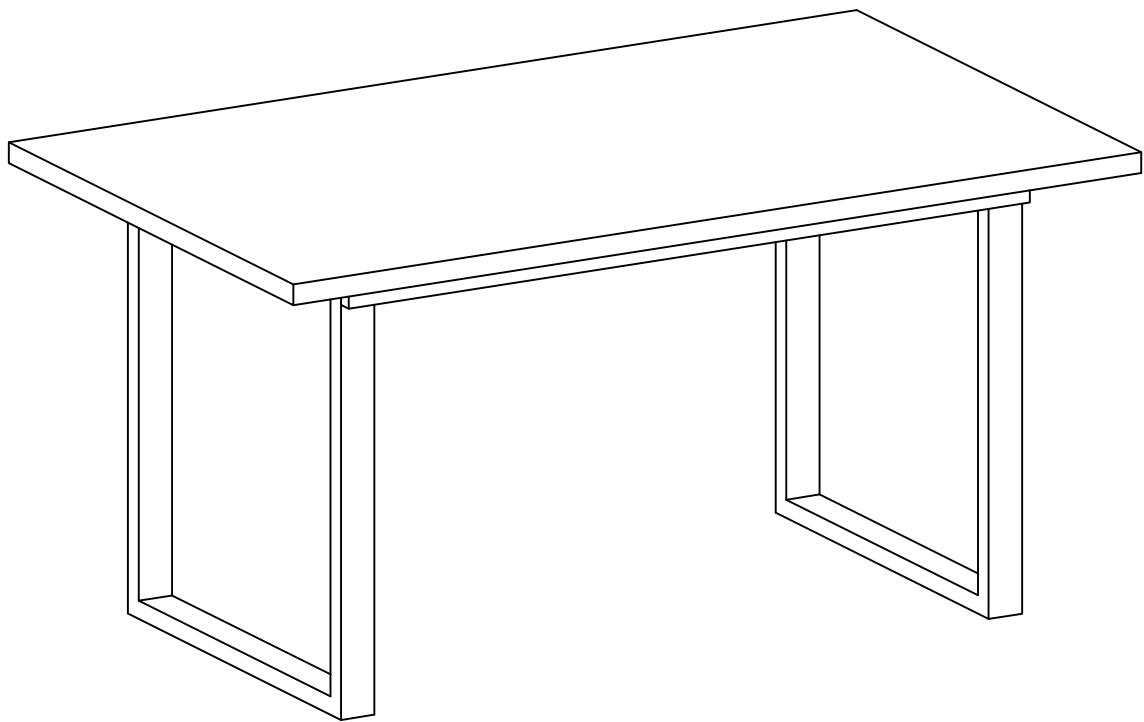

IMPORTANT NOTE :

- ① PLACE ALL PARTS ON A CLEAN AND SMOOTH SURFACE SUCH AS A RUG OR CARPET TO AVOID THE PARTS FROM BEING SCRATCHED.
- ② BEFORE YOU BEGIN,KINDLY FOLLOW THE ASSEMBLY INSTRUCTIONS STEP BY STEP.
- ③ DO NOT TIGHTEN ALL SCREWS AND BOLTS UNTIL THE CHAIR IS FULLY SET-UP.

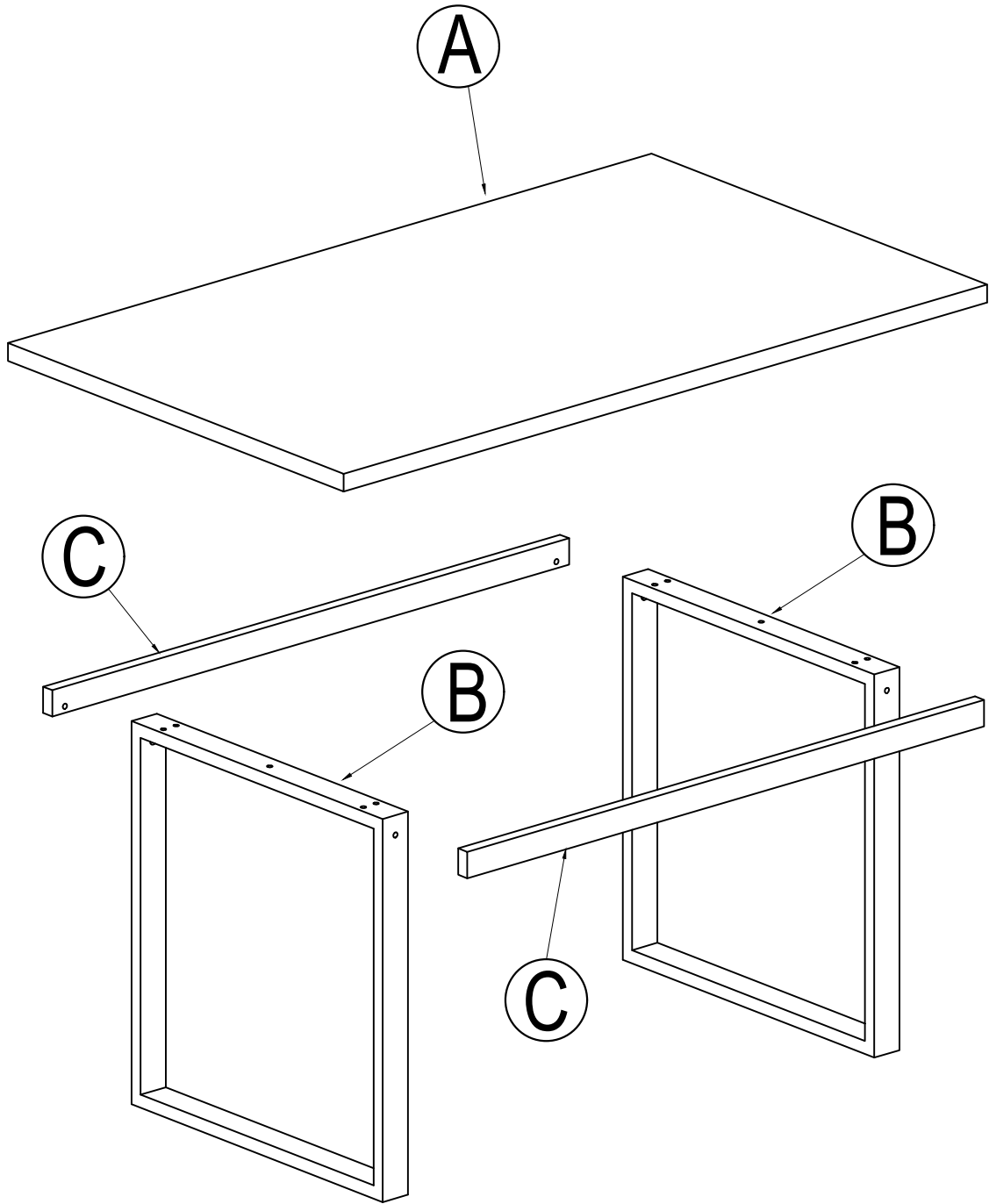

Part List

Hardware List

(A)

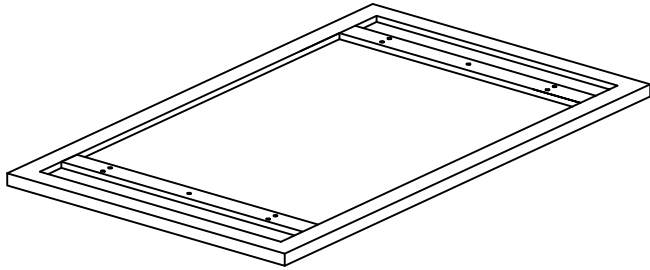

TABLE TOP (1 pc)

(B)

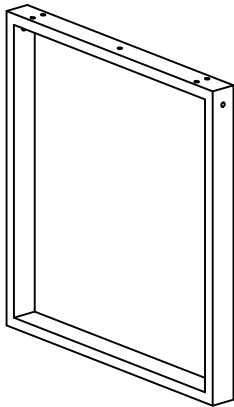

TABLE LEG (2 pcs)

(C)

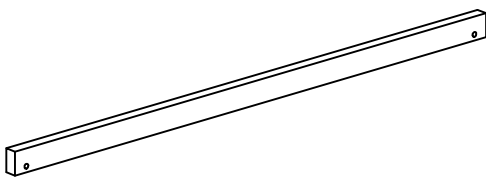
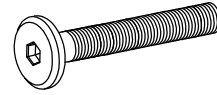

TABLE STRETCHER (2 pcs)

(1)



Ø5/16" x 40 mm

BOLT (14 pcs)

(2)



Ø5/16" x 13 mm

FLAT WASHER (14 pcs)

(3)

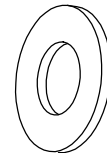

Ø5/16" x 19 mm

LOCK WASHER (10 pcs)

(4)

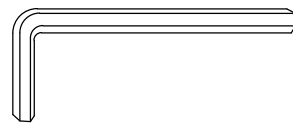

4 mm

ALLEN KEY (1 pc)

STEP 1:

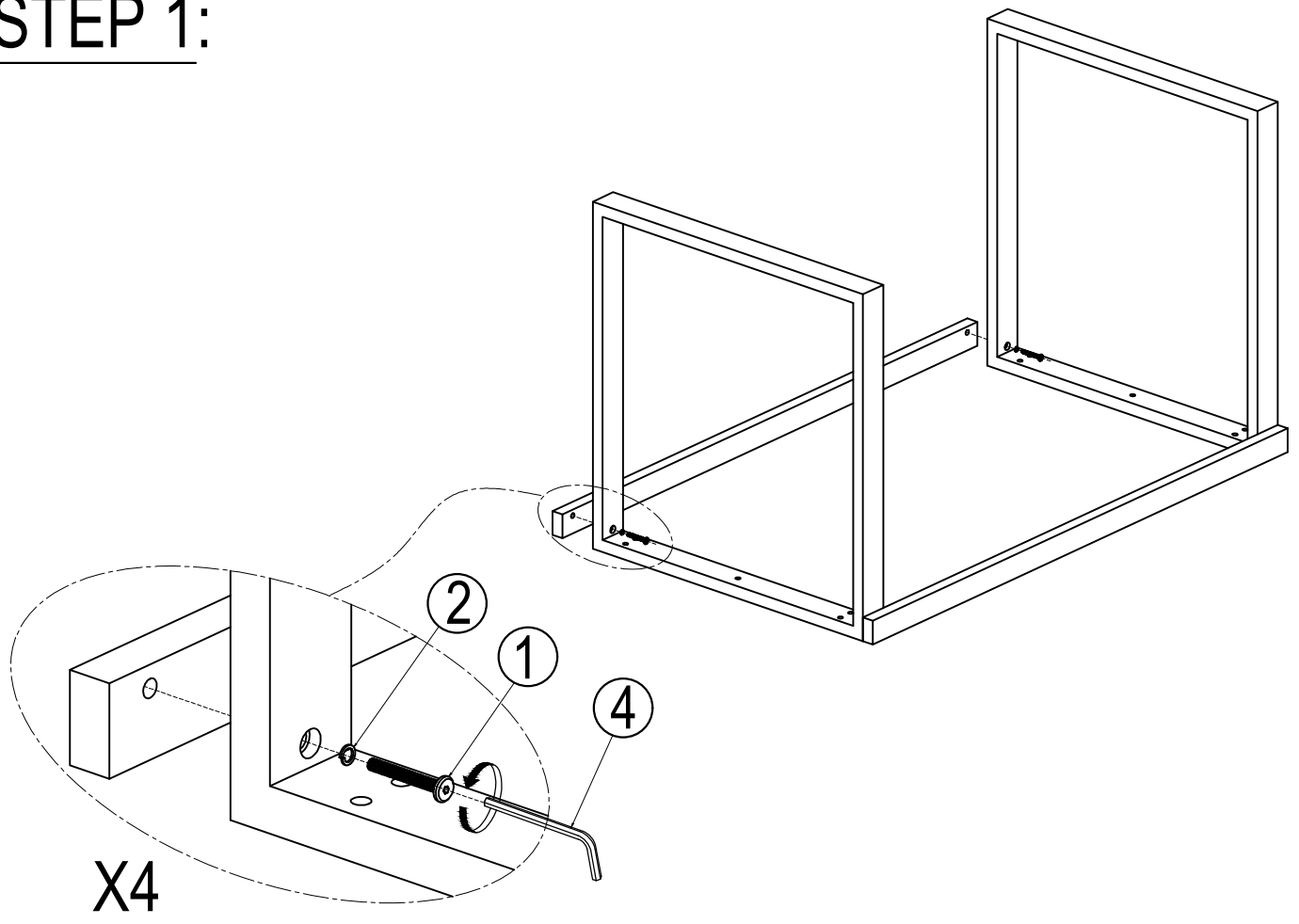

STEP 2:

