

ASSEMBLY INSTRUCTIONS

ITEM NO.WF283867

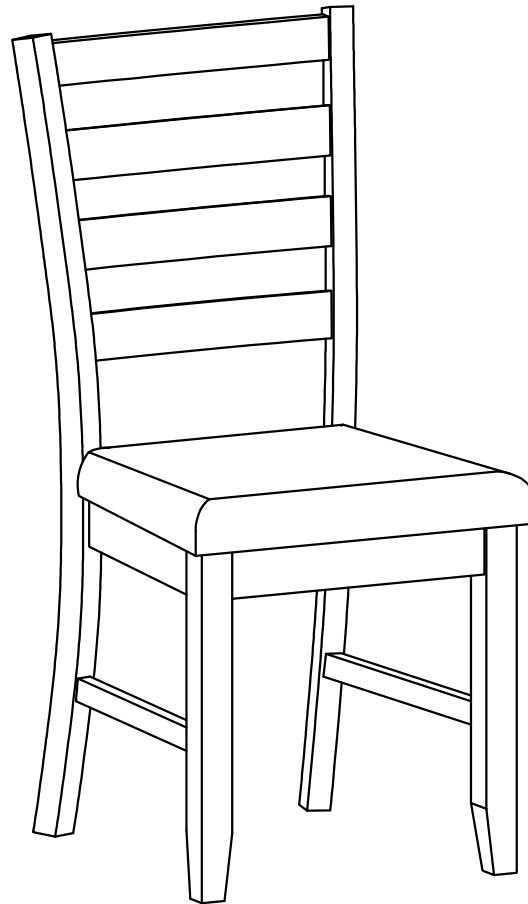



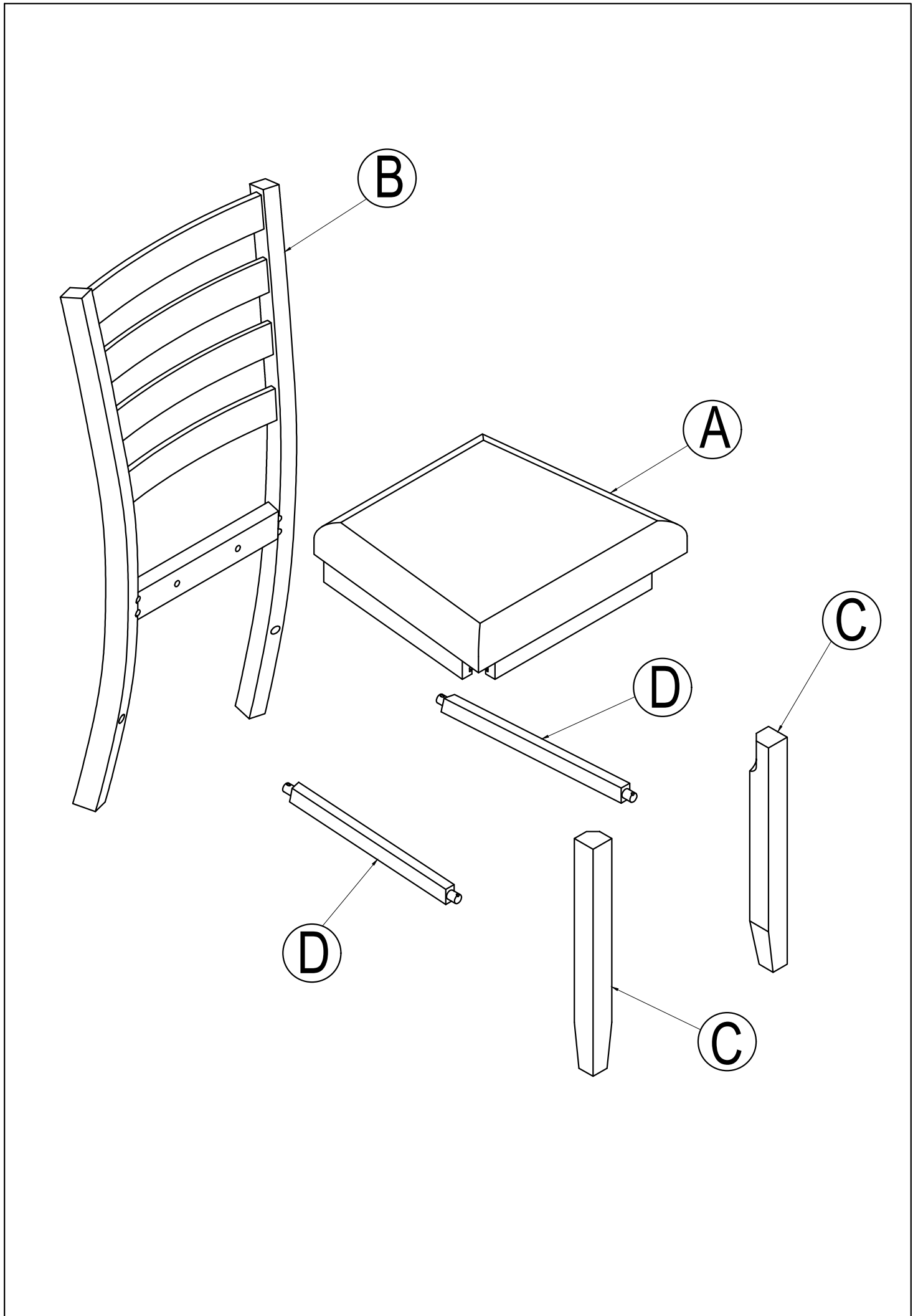

IMPORTANT NOTE :

- ① PLACE ALL PARTS ON A CLEAN AND SMOOTH SURFACE SUCH AS A RUG OR CARPET TO AVOID THE PARTS FROM BEING SCRATCHED.
- ② BEFORE YOU BEGIN,KINDLY FOLLOW THE ASSEMBLY INSTRUCTIONS STEP BY STEP.
- ③ DO NOT TIGHTEN ALL SCREWS AND BOLTS UNTIL THE CHAIR IS FULLY SET-UP.

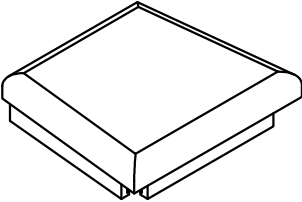
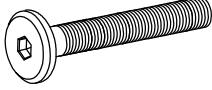
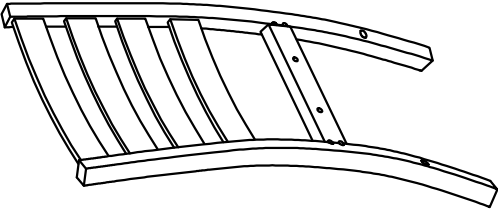
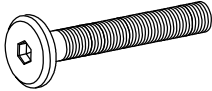
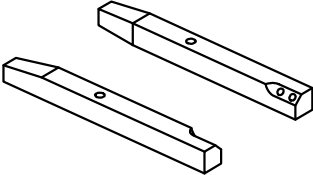
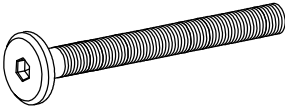

Part List

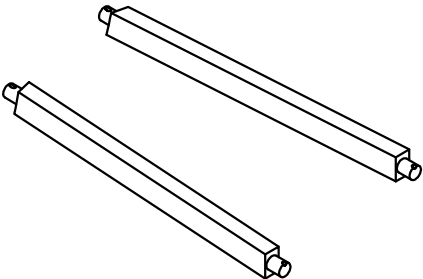
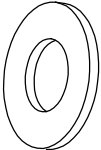
Hardware List

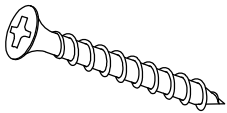
<p>A</p> 	<p>1</p>  <p>Ø 1/4" x 40mm</p>
<p>CUSHION SEAT (4PC)</p>	<p>BOLT (8 pcs)</p>
<p>B</p> 	<p>2</p>  <p>Ø 1/4" x 60 mm</p>
<p>CHAIR BACK (4PCS)</p>	<p>BOLT (16 pcs)</p>
<p>C</p> 	<p>3</p>  <p>Ø 1/4" x 80 mm</p>
<p>FRONT LEGS (8PCS) (Left / Right)</p>	<p>4</p>  <p>Ø5/16" x 13 mm</p>
<p>D</p> 	<p>5</p>  <p>Ø5/16" x 19 mm</p>
<p>SIDE STRETCHERS (8PCS) (Left / Right)</p>	<p>LOCK WASHER (40 pcs)</p>
<p>6</p> 	<p>4 mm</p> <p>ALLEN KEY (1 pc)</p>
<p>7</p> 	<p>#4 x 38 mm</p> <p>WOOD SCREWS (16 PCS)</p>

STEP 1:

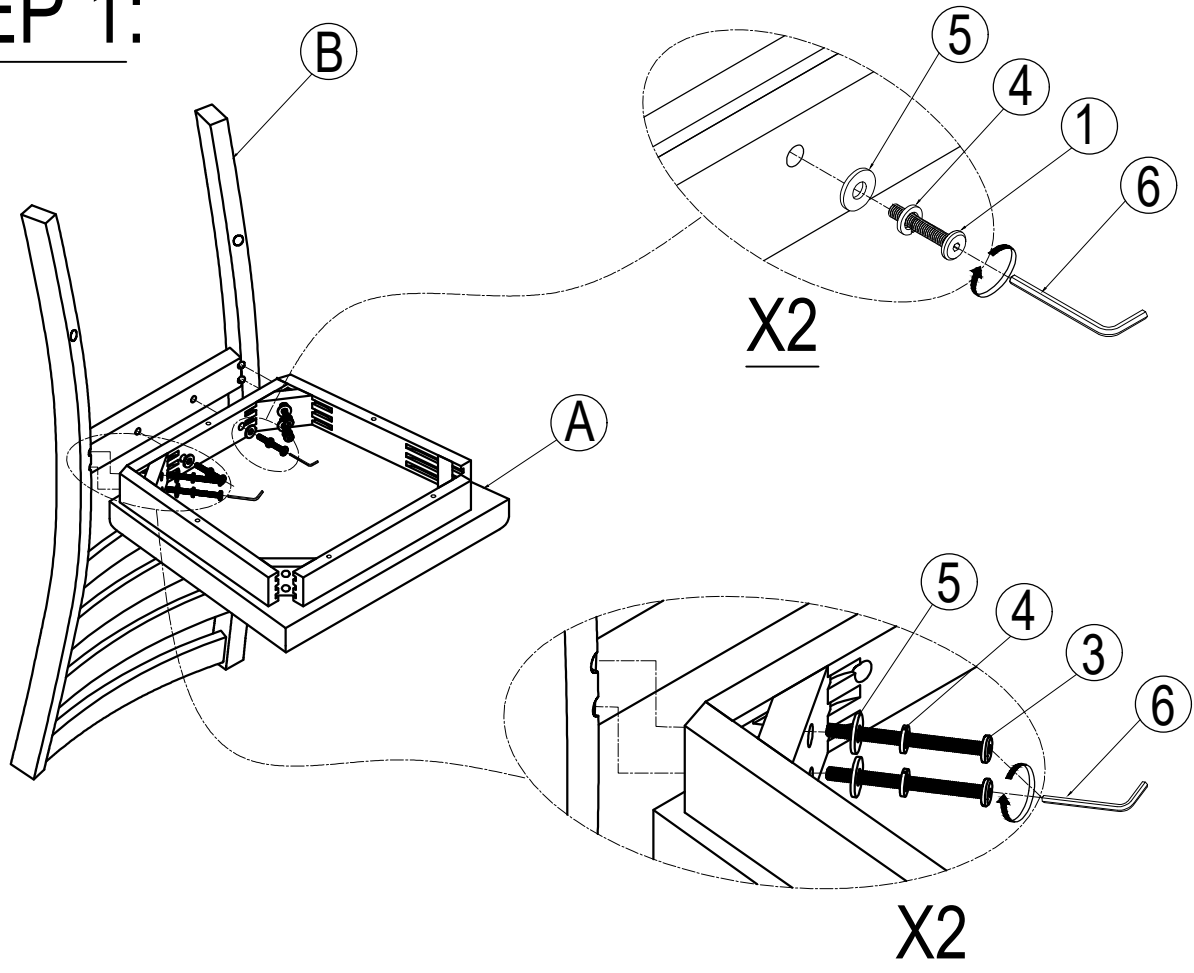

STEP 2:

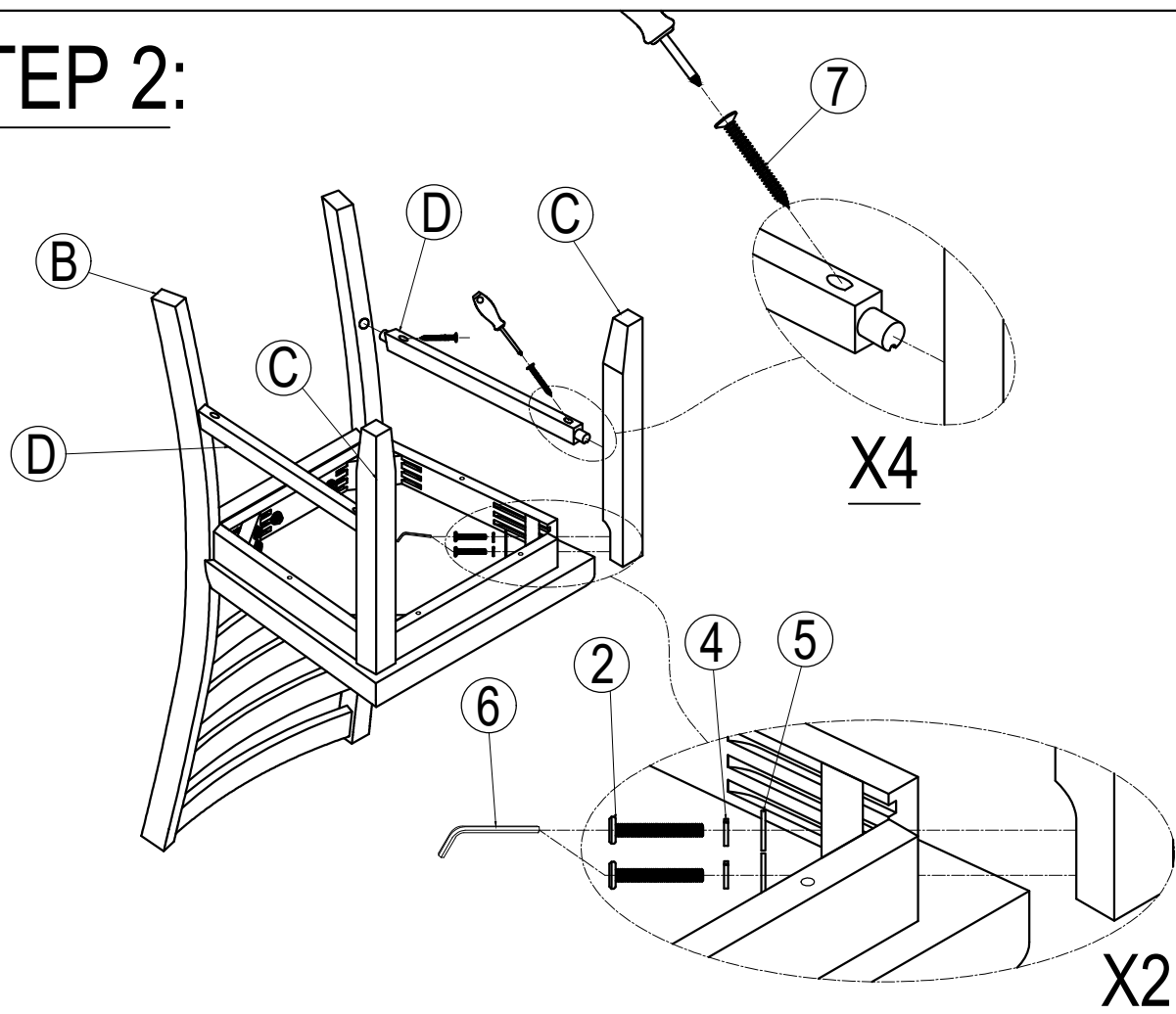

ASSEMBLY INSTRUCTIONS

ITEM NO.WF283867

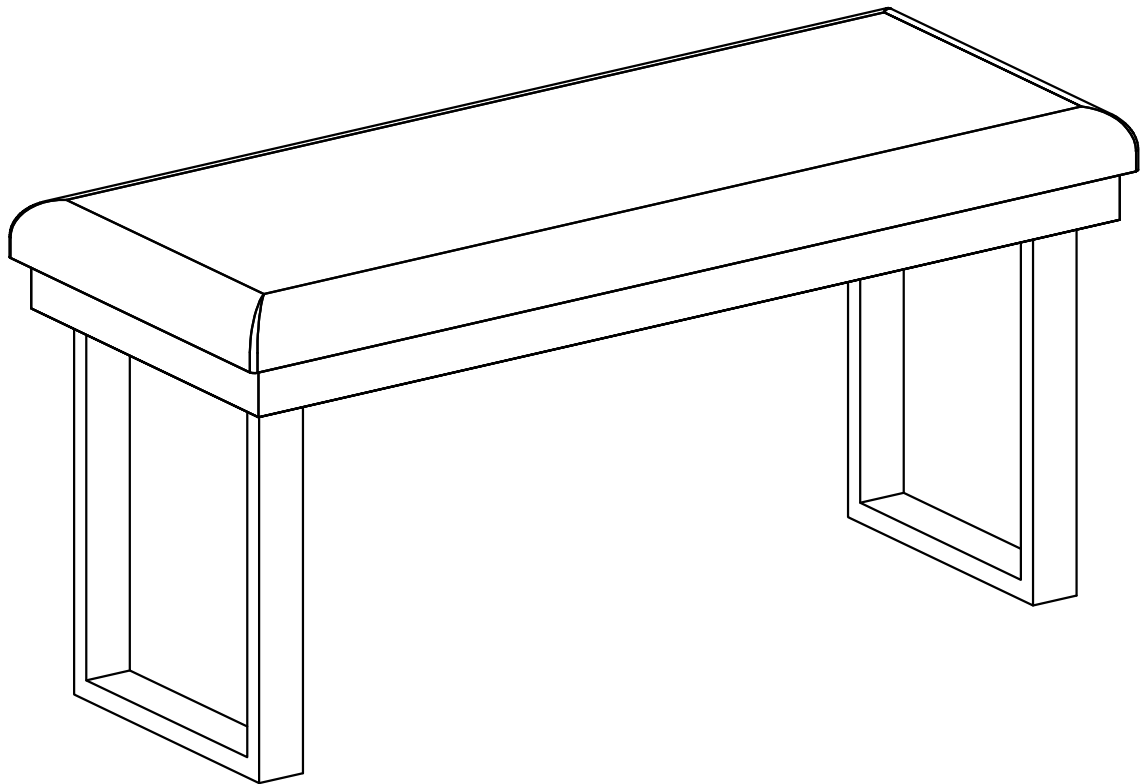



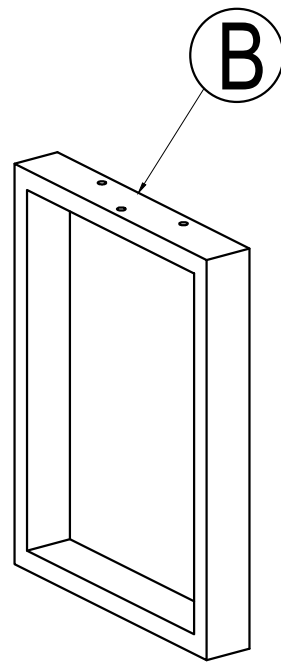
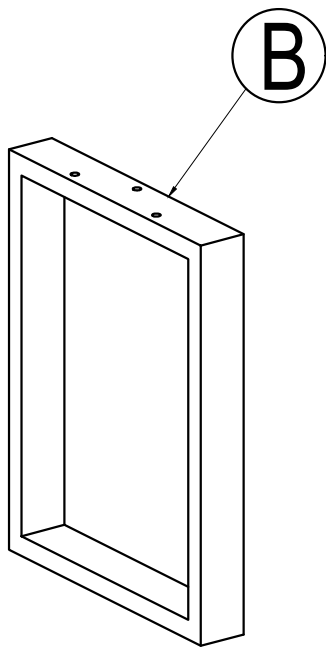
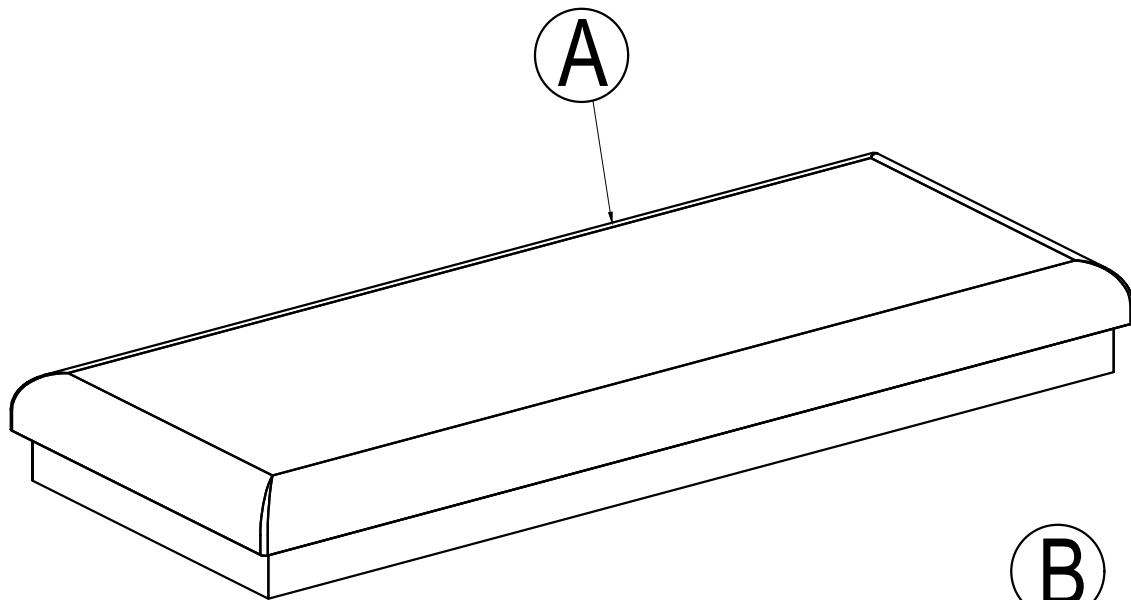

IMPORTANT NOTE :

- ① PLACE ALL PARTS ON A CLEAN AND SMOOTH SURFACE SUCH AS A RUG OR CARPET TO AVOID THE PARTS FROM BEING SCRATCHED.
- ② BEFORE YOU BEGIN,KINDLY FOLLOW THE ASSEMBLY INSTRUCTIONS STEP BY STEP.
- ③ DO NOT TIGHTEN ALL SCREWS AND BOLTS UNTIL THE CHAIR IS FULLY SET-UP.

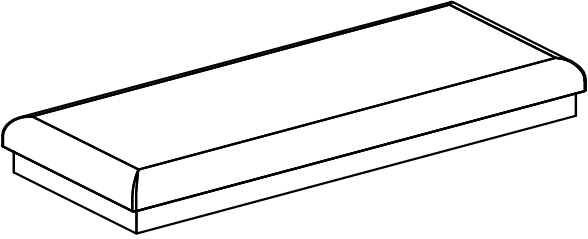
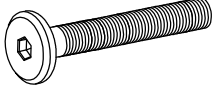

Part List

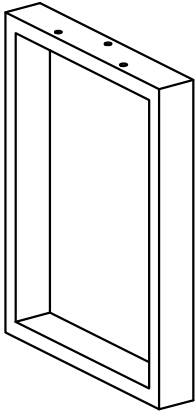
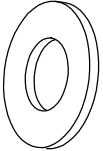
Hardware List

<p>Ⓐ</p>  <p>BENCH CUSHION SEAT (1 pc)</p>	<p>①</p>  <p>Ø1/4" x 40 mm BOLT (6 pcs)</p> <p>②</p>  <p>Ø5/16" x 13 mm FLAT WASHER (6 pcs)</p>
<p>Ⓑ</p>  <p>BENCH LEG (2 pcs)</p>	<p>③</p>  <p>Ø5/16" x 19 mm LOCK WASHER (6 pcs)</p> <p>④</p>  <p>4 mm ALLEN KEY (1 pc)</p>

STEP 1:

