

一 First

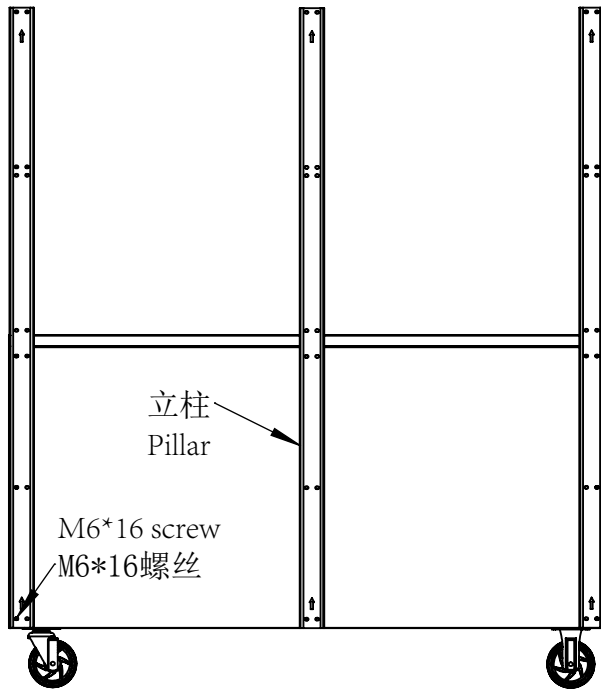

使用M6*16螺丝9个，连接立柱和箱体。

Using 9pcs M6*16 screw to connect pillar and the middle cabinet

二 Second

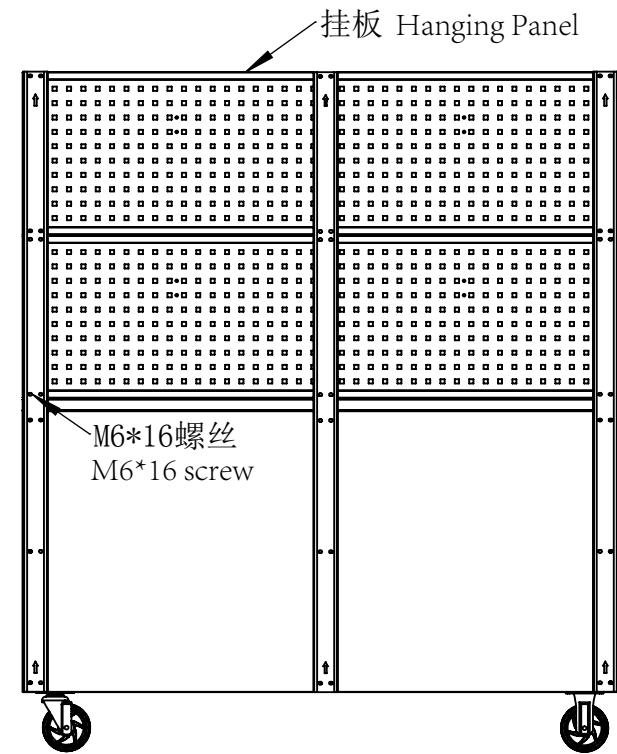

使用M6*16螺丝12个，连接立柱和挂板。

Using 12pcs M6*16 screw to connect pillar and hanging panel

三 Third

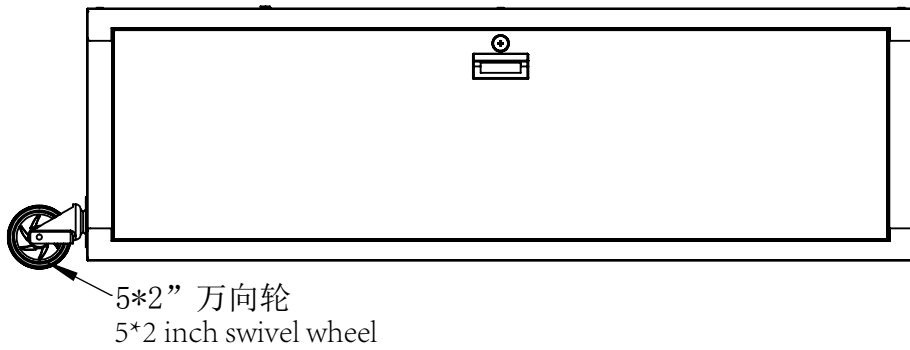

侧柜放倒，门打开，使用M8*16六角螺丝8个/M8平垫16个/M8螺母8个，安装5*2" 万向脚轮2个。

Put the side cabinet down, open the door, using 8pcs M8*16 screw/ 16pcs M8 gasket/ 8pcs M8 nut to assemble 2pcs 5*2 inch swivel wheel.

四 Fourth

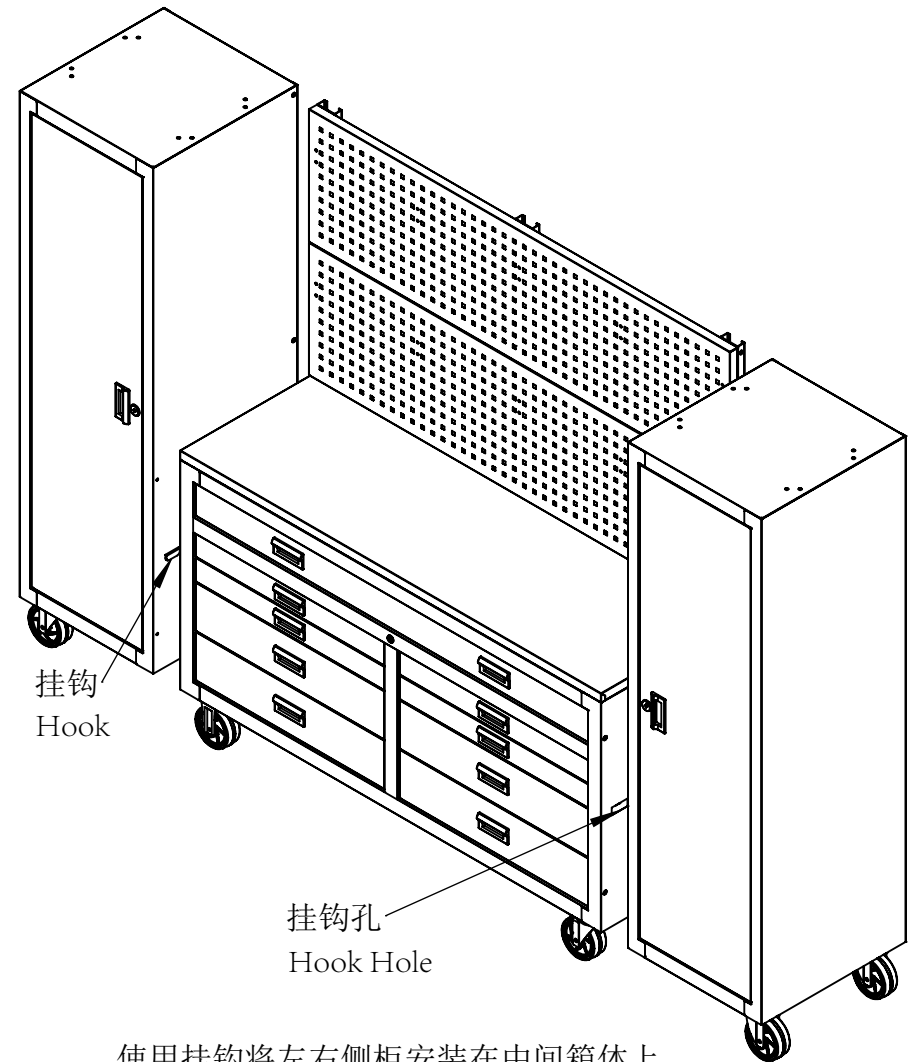

使用挂钩将左右侧柜安装在中间箱体上

Using the hook assemble the left and right side cabinet to the middle cabinet

五 Fifth

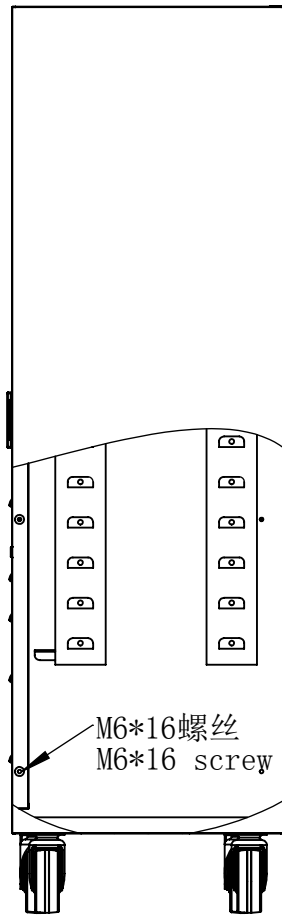

打开侧门使用M6*16螺丝4个连接侧柜。两侧柜共用8个。
Opening the side cabinet door, using 4pcs M6*16 screw to connect the side cabinet.
2 side cabinets total use 8pcs M6*16 screw.

六 Sixth

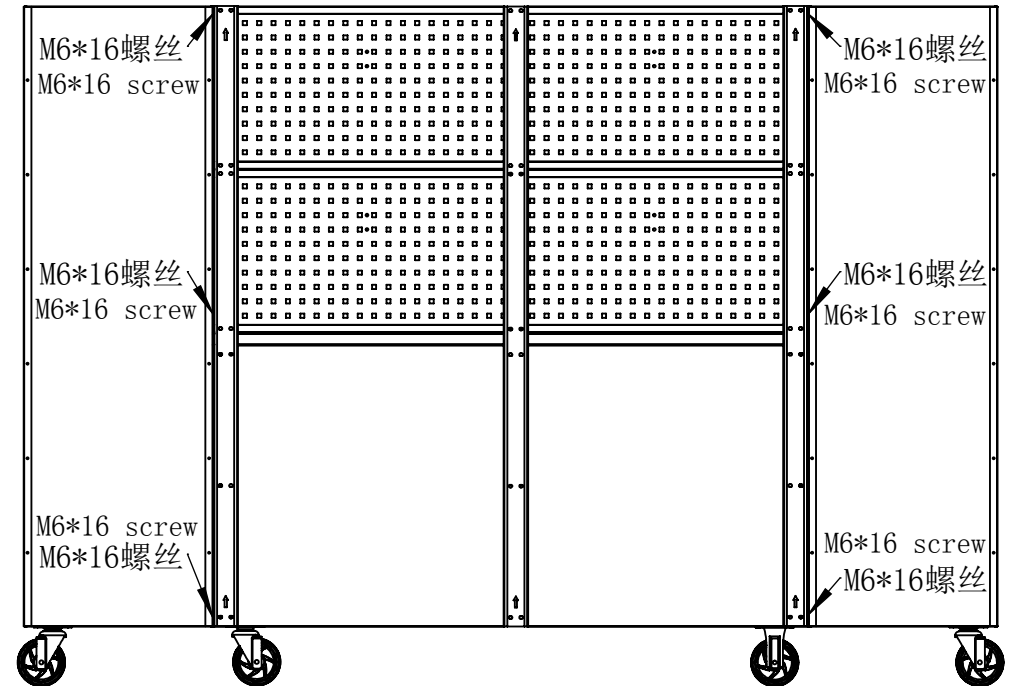

使用M6*16螺丝6个，连接立柱和侧柜

Using 6pcs M6*16 screw to connect pillar and side cabinet