

**ASSEMBLY INSTRUCTION**  
**SKU CODE: (WF310458-WF310459-WF310460)**

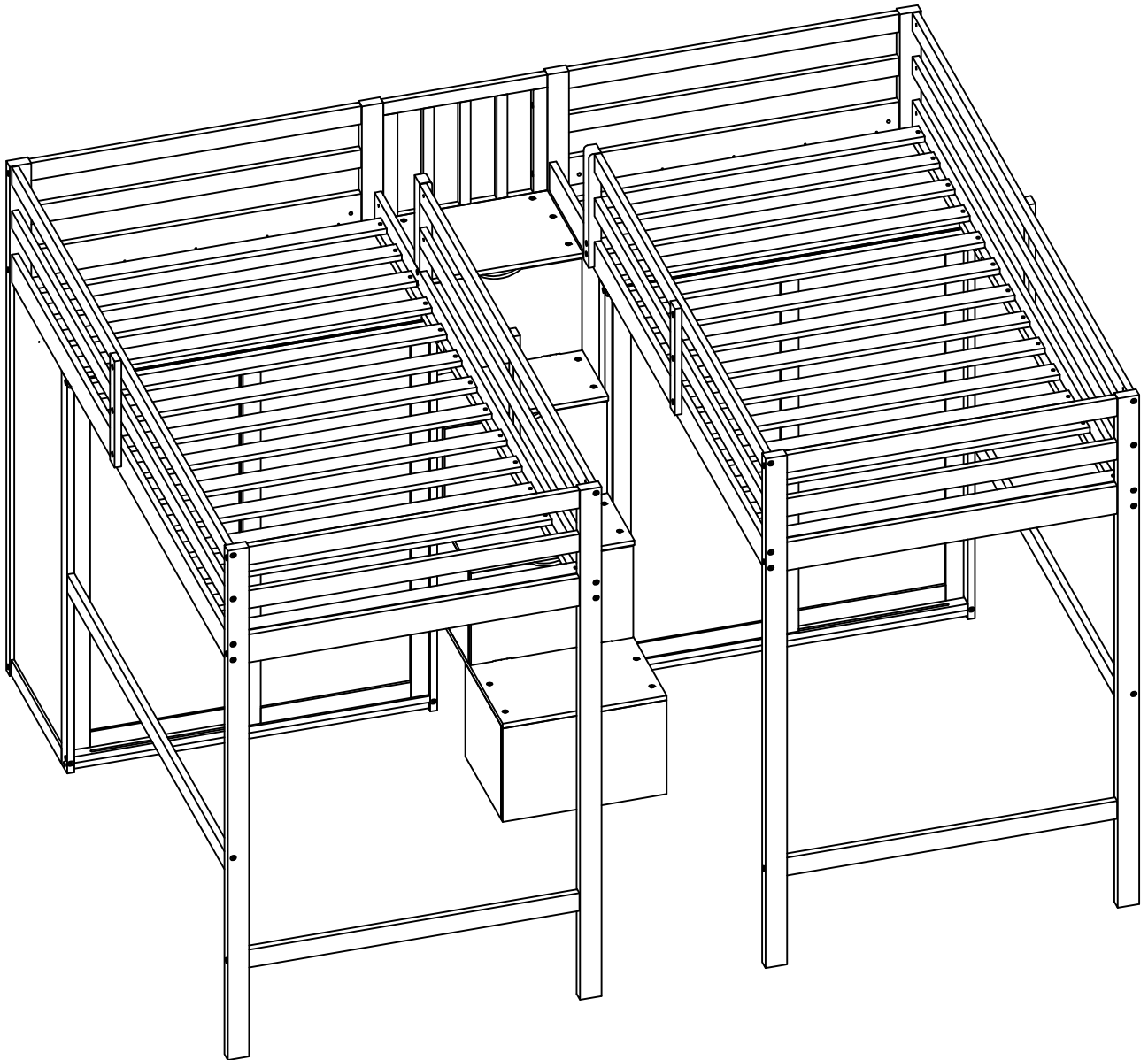

# **! SAFETY WARNINGS !**

1. This bed is designed for use only mattress (es) meeting the following specifications on the upper bunk, and lower bunk





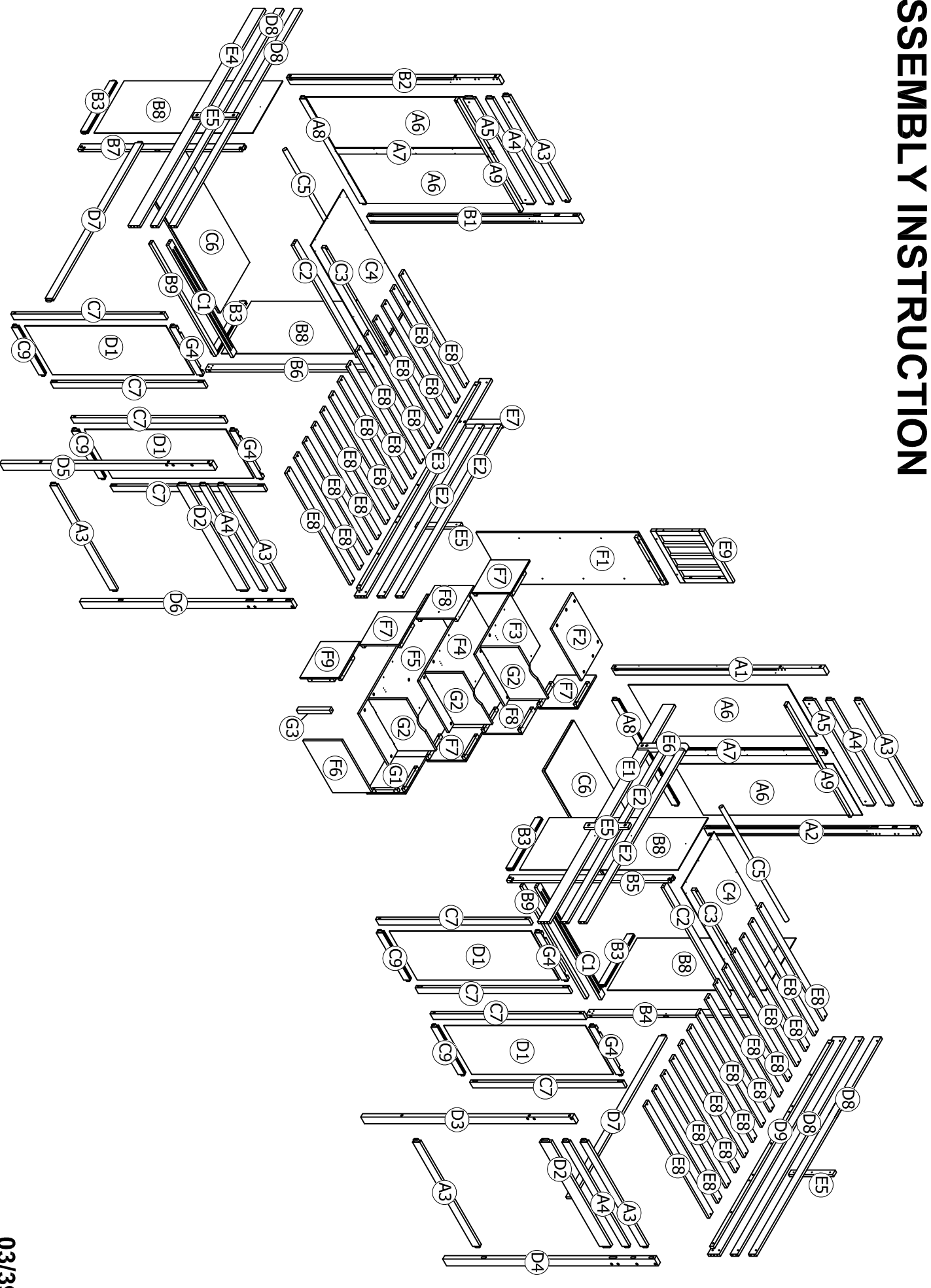

<b>Upper bed Bed Type</b>	<b>Length</b>	<b>Width</b>	<b>Thickness</b>
<i>Twin Standard</i>	<i>74" - 75"</i>	<i>38 1/2"</i>	<i>6" max</i>

2. Replacement parts, including additional guardrails, maybe obtained from any of our (GIGACLOUD TECHNOLOGY (USA) INC. 18961 ARENTH AVENUE CITY OF INDUSTRY, CA, 91748) dealers
3. Follow the information on the warnings appearing on the upper bunk bed end structure and on the carton. Do not remove warning label from bed
4. Always use the recommended size mattresses or mattress supports, or both, to help prevent the likelihood of entrapment or falls.
5. Surface of mattress must be at least 5" (127mm) below the upper edge of guardrails
6. Do not allow children under 6 years of age to use the upper bunk.
7. Periodically check and ensure that the guardrail, ladder, and other components are in their proper position, free from damage, and that all connectors are tight.
8. Do not allow horseplay on or under the bed and prohibit jumping on the bed.
9. Always use the ladder for entering and leaving the upper bunk.
10. Do not use substitute part. Contact the manufacture or dealer for replacement part
11. Use of a night light may provide added safety precaution for a child using the upper bunk..
12. Always use guardrails on both long sides of the upper bunk. If the bunk bed will be placed next to the wall, the guardrail that runs the full length of the bed should be placed against the wall to prevent entrapment between the bed and wall.
13. The use of water or sleep flotation mattresses is prohibited
14. STRANGULATION HAZARD - Never attach or hang items to any part of the bunk bed that are not designed for use with the bed; for example, but not limited to, hook, belts and jump ropes
15. Keep these instruction for future reference
16. Prohibit more than one person on upper bunk
17. We recommend assembling your bunk bed on the shipping carton to protect your floor or carpet
18. Be certain all staples are out of the box before beginning assembly on the shipping carton.

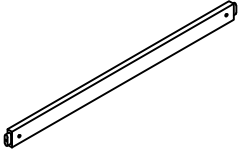
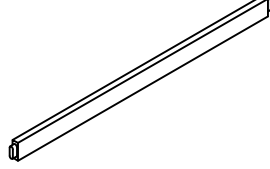
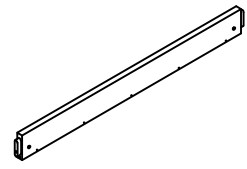

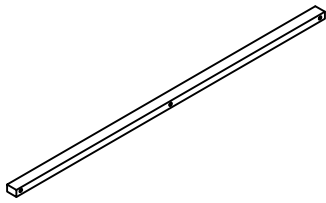
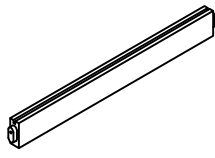
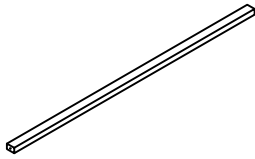
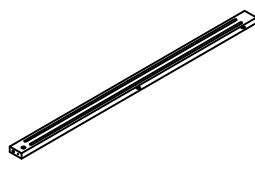
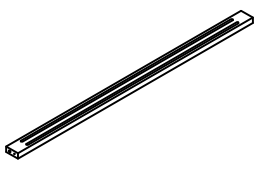
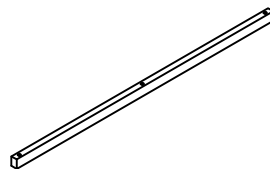
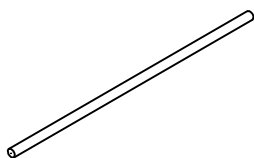
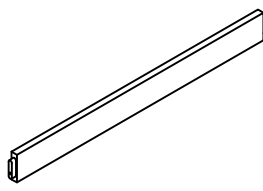



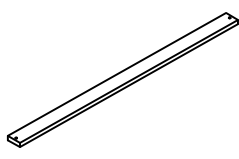
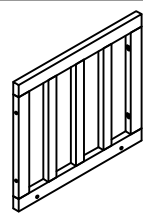
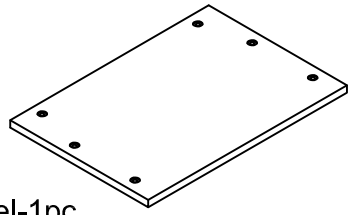
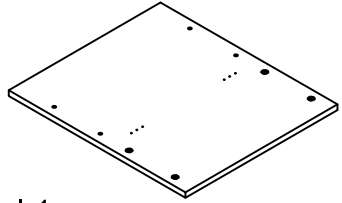
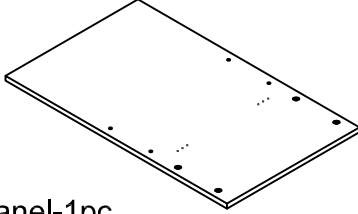
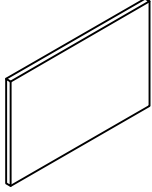
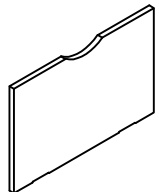
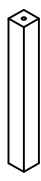

# ASSEMBLY INSTRUCTION





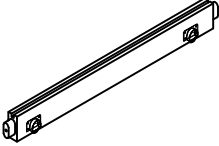



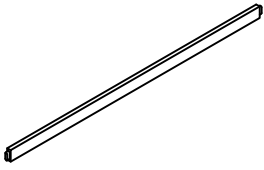
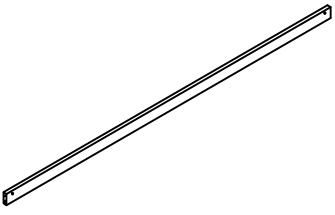
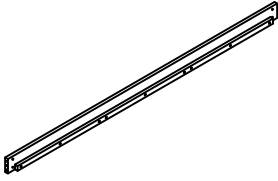
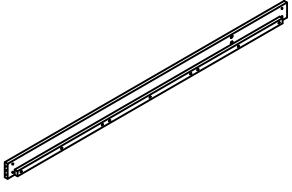
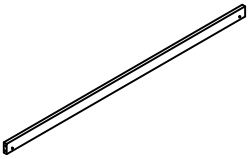
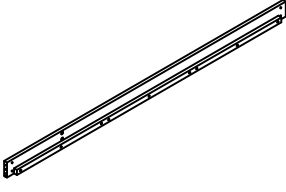
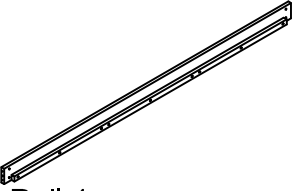
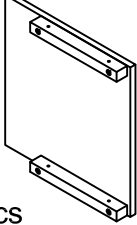
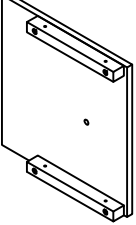
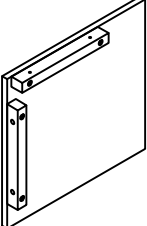
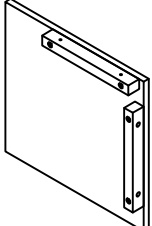
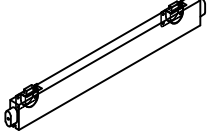

# Part List (Box 1-WF310458)

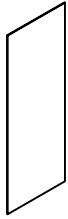
<p><b>A3</b></p>  <p>WoodBar-6pcs</p>	<p><b>A4</b></p>  <p>WoodBar-4pcs</p>	<p><b>A5</b></p>  <p>WoodBar-2pcs</p>
<p><b>A8</b></p>  <p>WoodBar-2pcs</p>	<p><b>A9</b></p>  <p>WoodBar-2pcs</p>	<p><b>B3</b></p>  <p>WoodBar-4pcs</p>
<p><b>B9</b></p>  <p>WoodBar-2pcs</p>	<p><b>C1</b></p>  <p>WoodBar-2pcs</p>	<p><b>C2</b></p>  <p>WoodBar-2pcs</p>
<p><b>C3</b></p>  <p>WoodBar-2pcs</p>	<p><b>C5</b></p>  <p>WoodBar-2pcs</p>	<p><b>D2</b></p>  <p>WoodBar-2pcs</p>
<p><b>E5</b></p>  <p>WoodBar-4pcs</p>	<p><b>E6</b></p>  <p>WoodBar-1pc</p>	<p><b>E7</b></p>  <p>WoodBar-1pc</p>
<p><b>E8</b></p>  <p>Slats-28pcs</p>	<p><b>E9</b></p>  <p>Stair railing above-1pc</p>	<p><b>F2</b></p>  <p>Panel-1pc</p>
<p><b>F3</b></p>  <p>Panel-1pc</p>	<p><b>F4</b></p>  <p>Panel-1pc</p>	<p><b>F6</b></p>  <p>Panel-1pc</p>
<p><b>G2</b></p>  <p>Panel-3pcs</p>	<p><b>G3</b></p>  <p>WoodBar-1pc</p>	

# Part List & Hardware List (Box 2-WF310459)

<p>A1</p>  <p>Leg-1pc</p>	<p>A2</p>  <p>Leg-1pc</p>	<p>B1</p>  <p>Leg-1pc</p>
<p>B2</p>  <p>Leg-1pc</p>	<p>C9</p>  <p>WoodBar-4pcs</p>	<p>D3</p>  <p>Leg-1pc</p>
<p>D4</p>  <p>Leg-1pc</p>	<p>D5</p>  <p>Leg-1pc</p>	<p>D6</p>  <p>Leg-1pc</p>
<p>D7</p>  <p>WoodBar-2pcs</p>	<p>D8</p>  <p>WoodBar-4pcs</p>	<p>D9</p>  <p>Side Rail-1pc</p>
<p>E1</p>  <p>Side Rail-1pc</p>	<p>E2</p>  <p>WoodBar-4pcs</p>	<p>E3</p>  <p>Side Rail-1pc</p>
<p>E4</p>  <p>Side Rail-1pc</p>	<p>F7</p>  <p>Panel-4pcs</p>	<p>F8</p>  <p>Panel-2pcs</p>
<p>F9</p>  <p>Panel-1pc</p>	<p>G1</p>  <p>Panel-1pc</p>	<p>G4</p>  <p>WoodBar-4pcs</p>

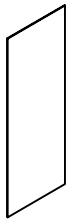
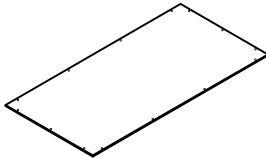
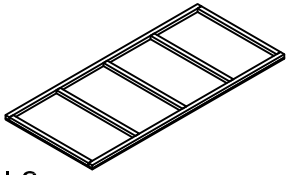
# Part List (Box 3-WF310460)

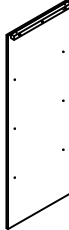
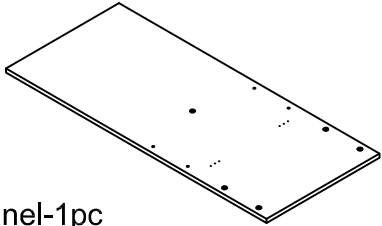
<p><b>A6</b></p>  <p>Panel-4pcs</p>	<p><b>A7</b></p>  <p>WoodBar-2pcs</p>	<p><b>B4</b></p>  <p>WoodBar-1pc</p>
<p><b>B5</b></p>  <p>WoodBar-1pc</p>	<p><b>B6</b></p>  <p>WoodBar-1pc</p>	<p><b>B7</b></p>  <p>WoodBar-1pc</p>
<p><b>B8</b></p>  <p>Panel-4pcs</p>	<p><b>C4</b></p>  <p>Panel-2pcs</p>	<p><b>C6</b></p>  <p>Panel-2pcs</p>
<p><b>C7</b></p>  <p>WoodBar-8pcs</p>	<p><b>D1</b></p>  <p>Panel-4pcs</p>	<p><b>F1</b></p>  <p>Panel-1pc</p>
<p><b>F5</b></p>  <p>Panel-1pc</p>		

# Hardware List (Box 2-WF310459)

<p>1</p>  <p>Screws 1/4" x30 44pcs</p>	<p>2</p>  <p>Screws 1/4" x50 18pcs</p>	<p>3</p>  <p>Screws 1/4" x60 4pcs</p>
<p>4</p>  <p>Screws 1/4" x70 20pcs</p>	<p>5</p>  <p>Ø1/4" x 30 mm Hex-Head bolts 5pcs</p>	<p>6</p>  <p>Ø1/4" x 60 mm Hex-Head bolts 7pcs</p>
<p>7</p>  <p>Ø1/4" x 80 mm Hex-Head bolts 30pcs</p>	<p>8</p>  <p>Ø1/4" x 100 mm Hex-Head bolts 28pcs</p>	<p>9</p>  <p>Ø1/4" x 15 mm T-Nut 4pcs</p>
<p>10</p>  <p>Ø1/4" x 13 mm Horizontal-Hole bolts 65pcs</p>	<p>11</p>  <p>Ø8 x 30 mm Wood dowel 8pcs</p>	<p>12</p>  <p>Ø10 x 40 mm Wood dowel 24pcs</p>
<p>13</p>  <p>M3 x 12 mm Wood Screws 34pcs</p>	<p>14</p>  <p>M4 x 30 mm Wood Screws 66pcs</p>	<p>15</p>  <p>M4 x 40 mm Wood Screws 12pcs</p>
<p>16</p>  <p>M4 x 15 mm Wood Screws 66pcs</p>	<p>17</p>  <p>Ø1/4" x 25 mm Hex-Head bolts 4pcs</p>	<p>18</p>  <p>Allen Key 1pc</p>
<p>19</p>  <p>8pcs</p>	<p>20</p>  <p>6pcs</p>	 <p>Assembly Tools Required (Not Included)</p>

**STEP1:** Following below illustration.

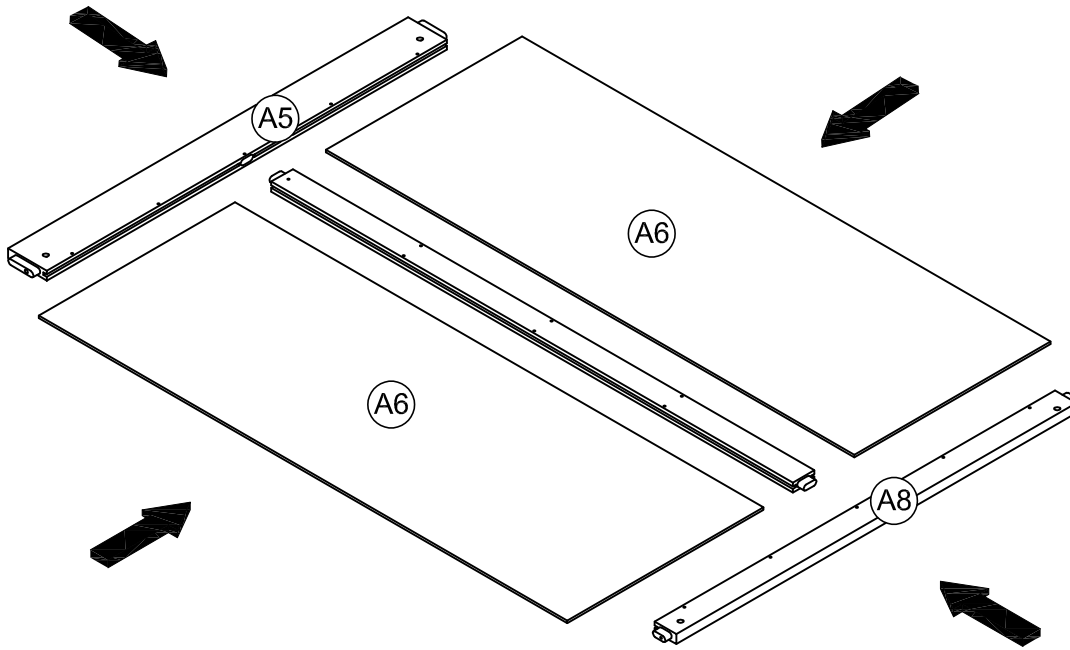

**STEP2:** Following below illustration.

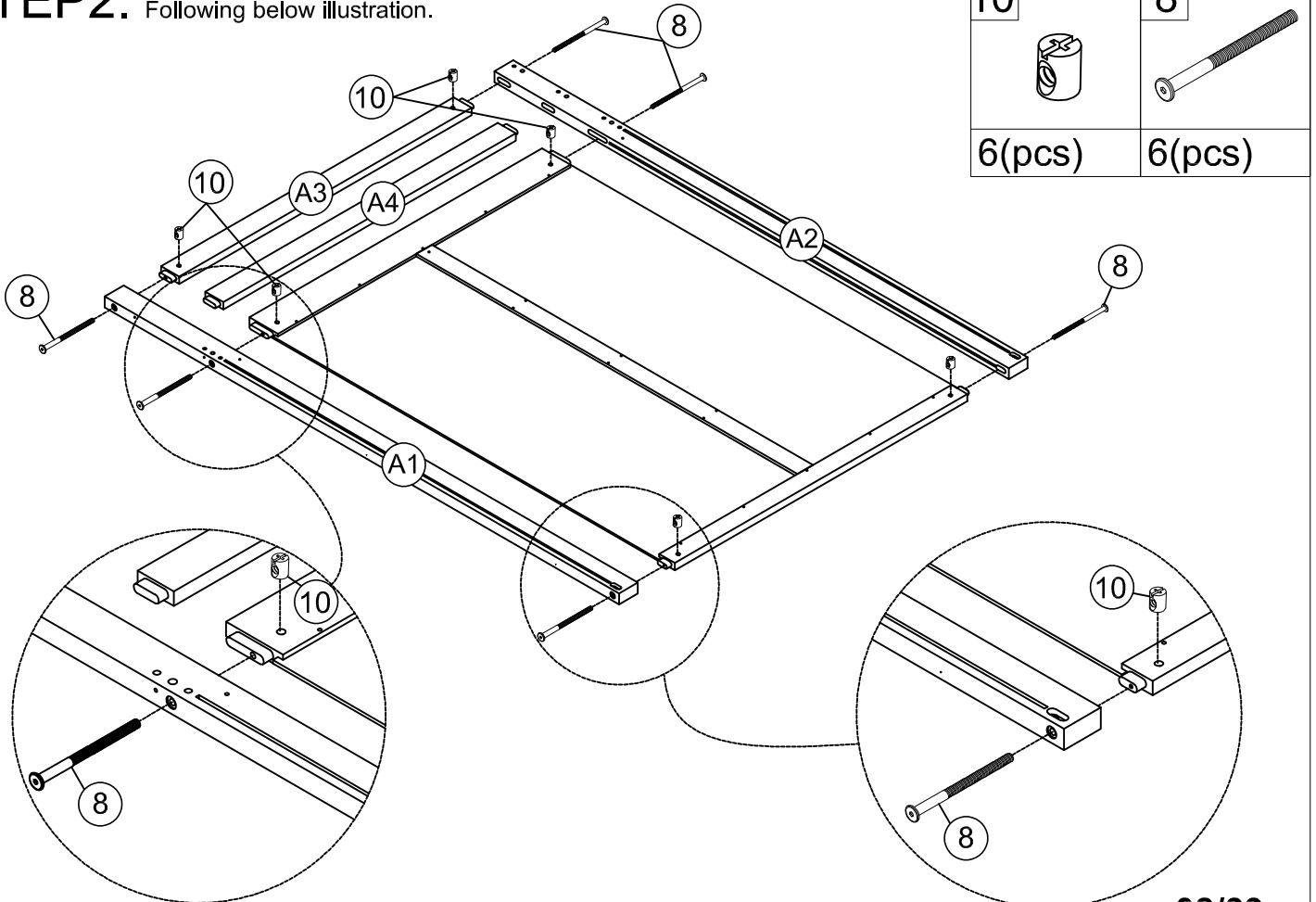



**STEP3:** Following below illustration.

16



16(pcs)

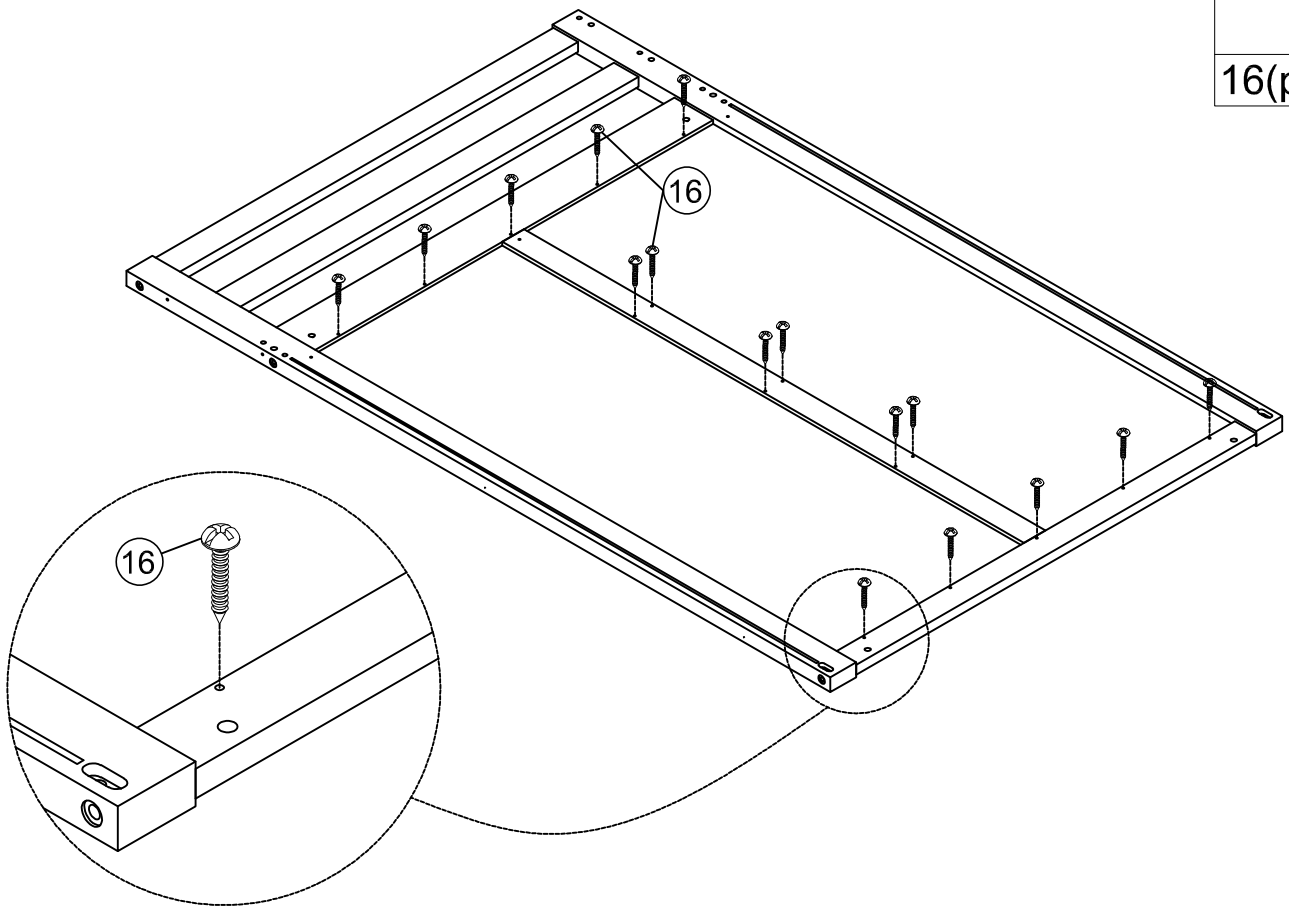

**STEP4:** Following below illustration.

15



3(pcs)

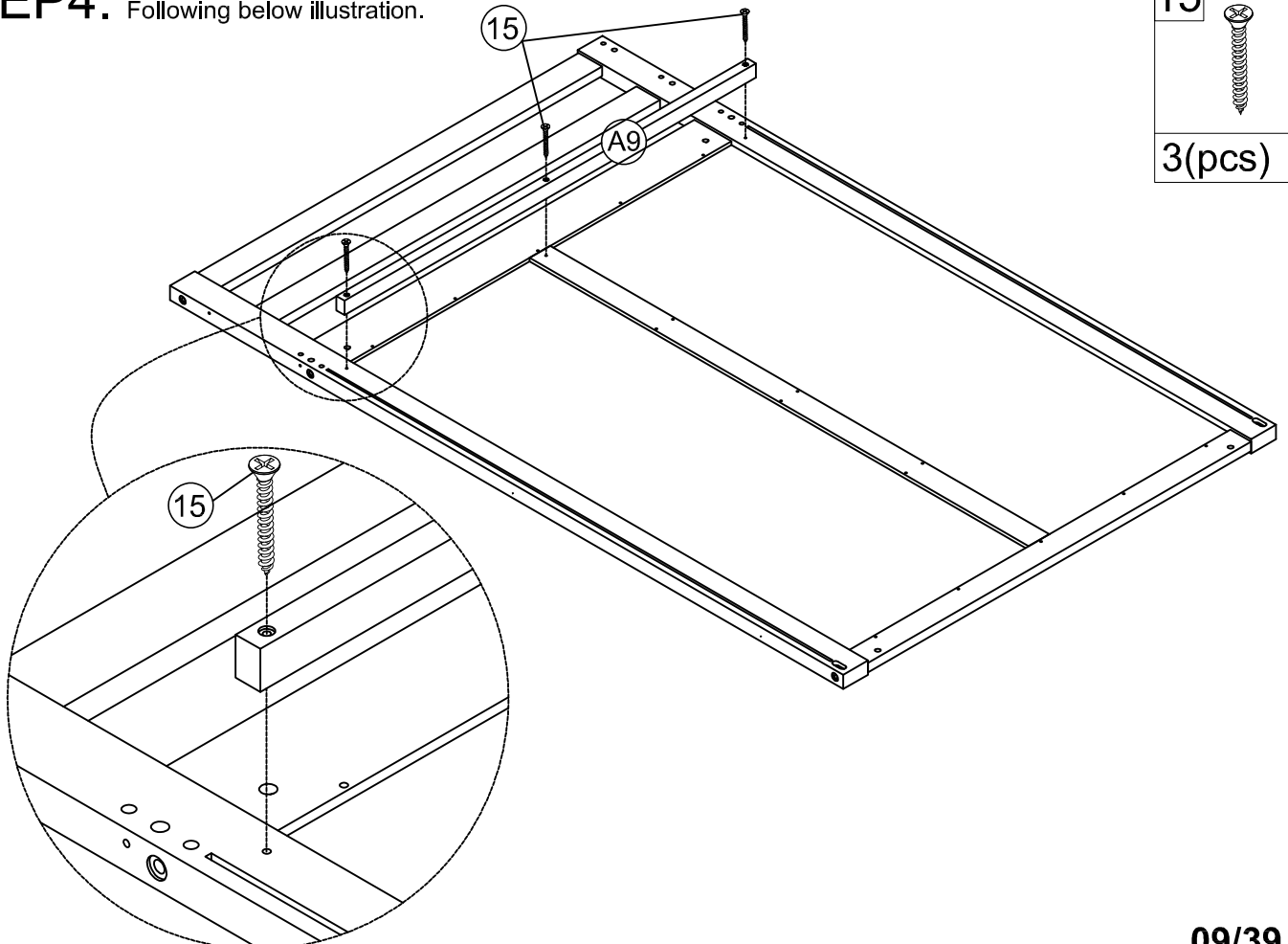

**STEP5:** Following below illustration.

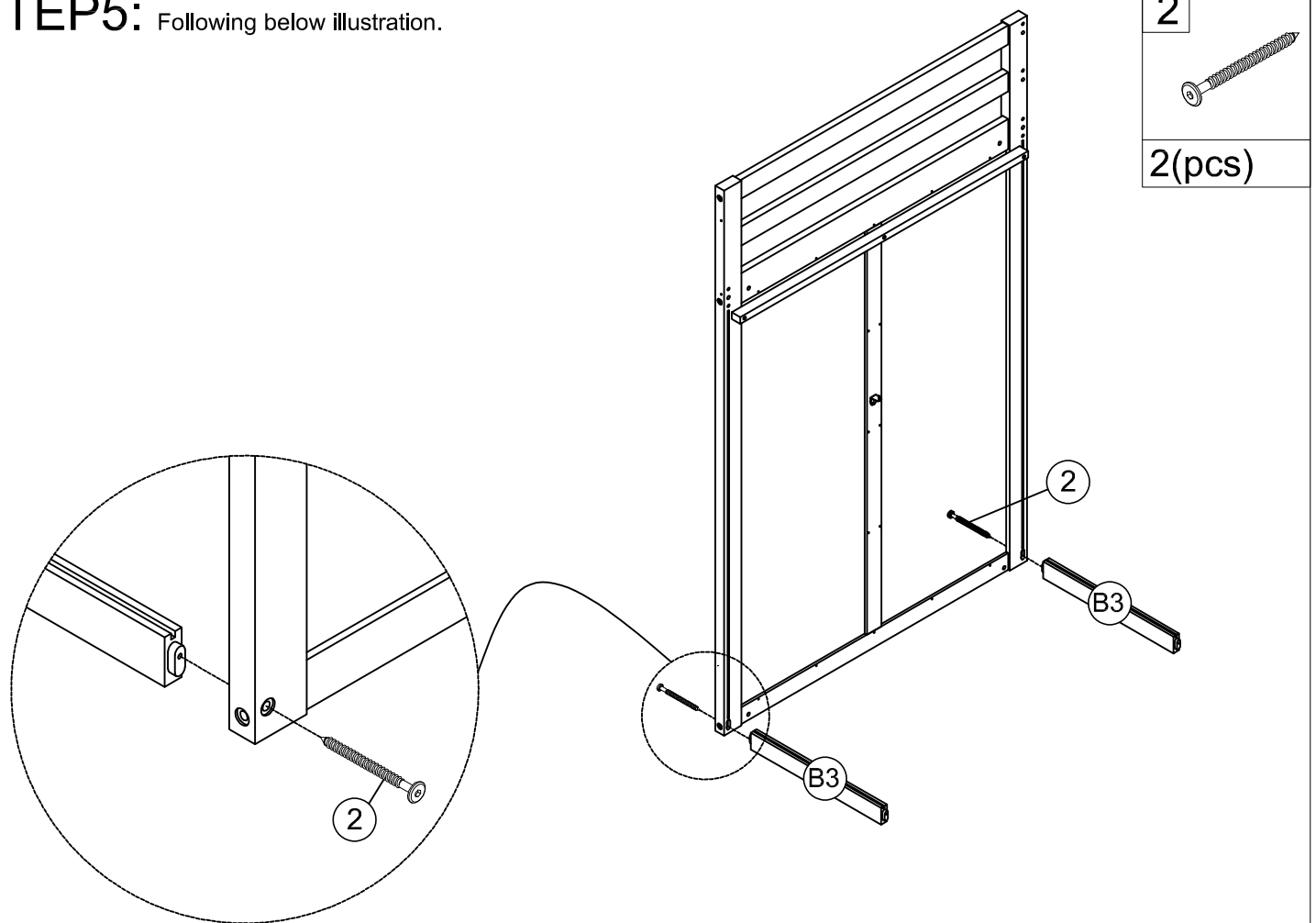

**STEP6:** Following below illustration.

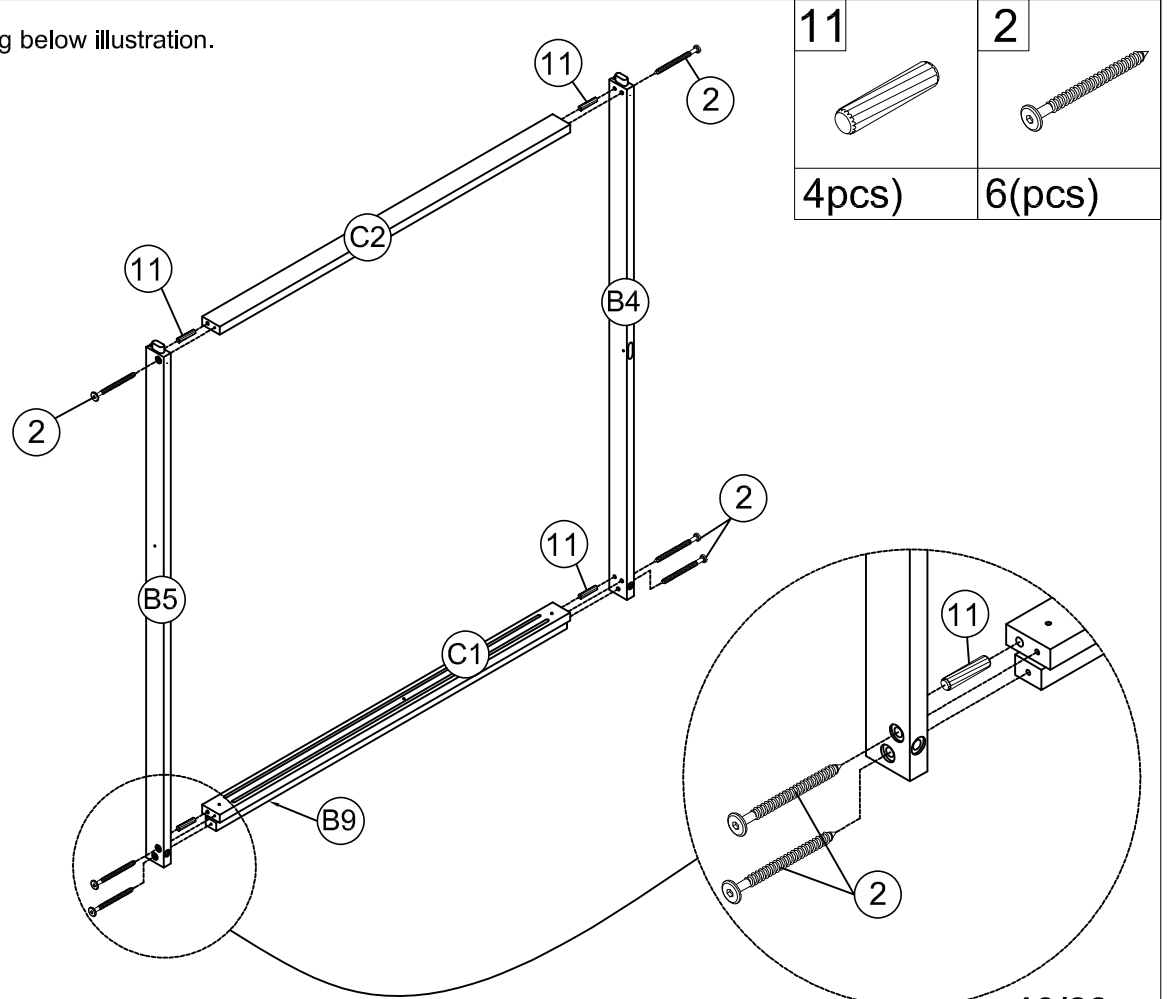

**STEP7:** Following below illustration.

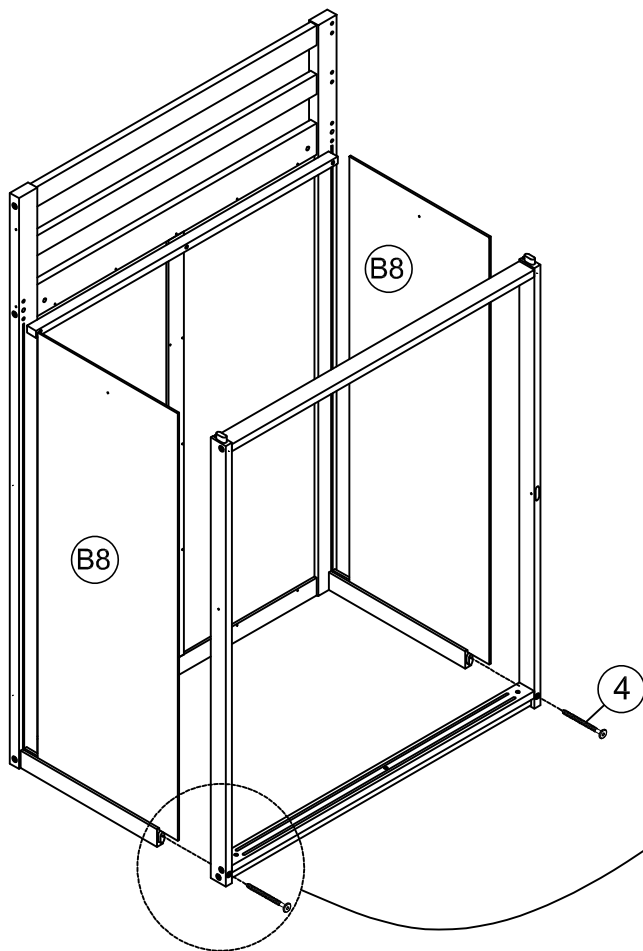

4

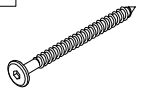

2(pcs)

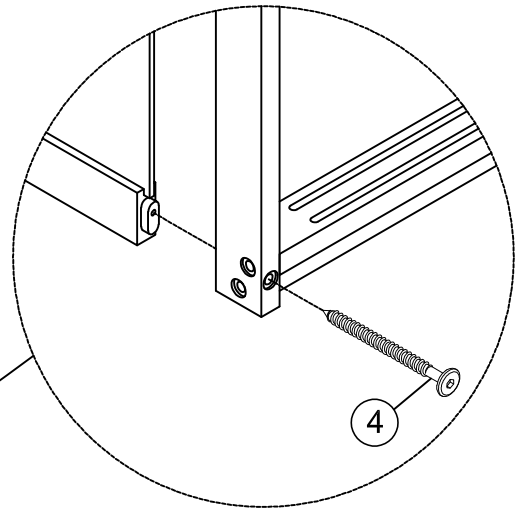

**STEP8:** Following below illustration.

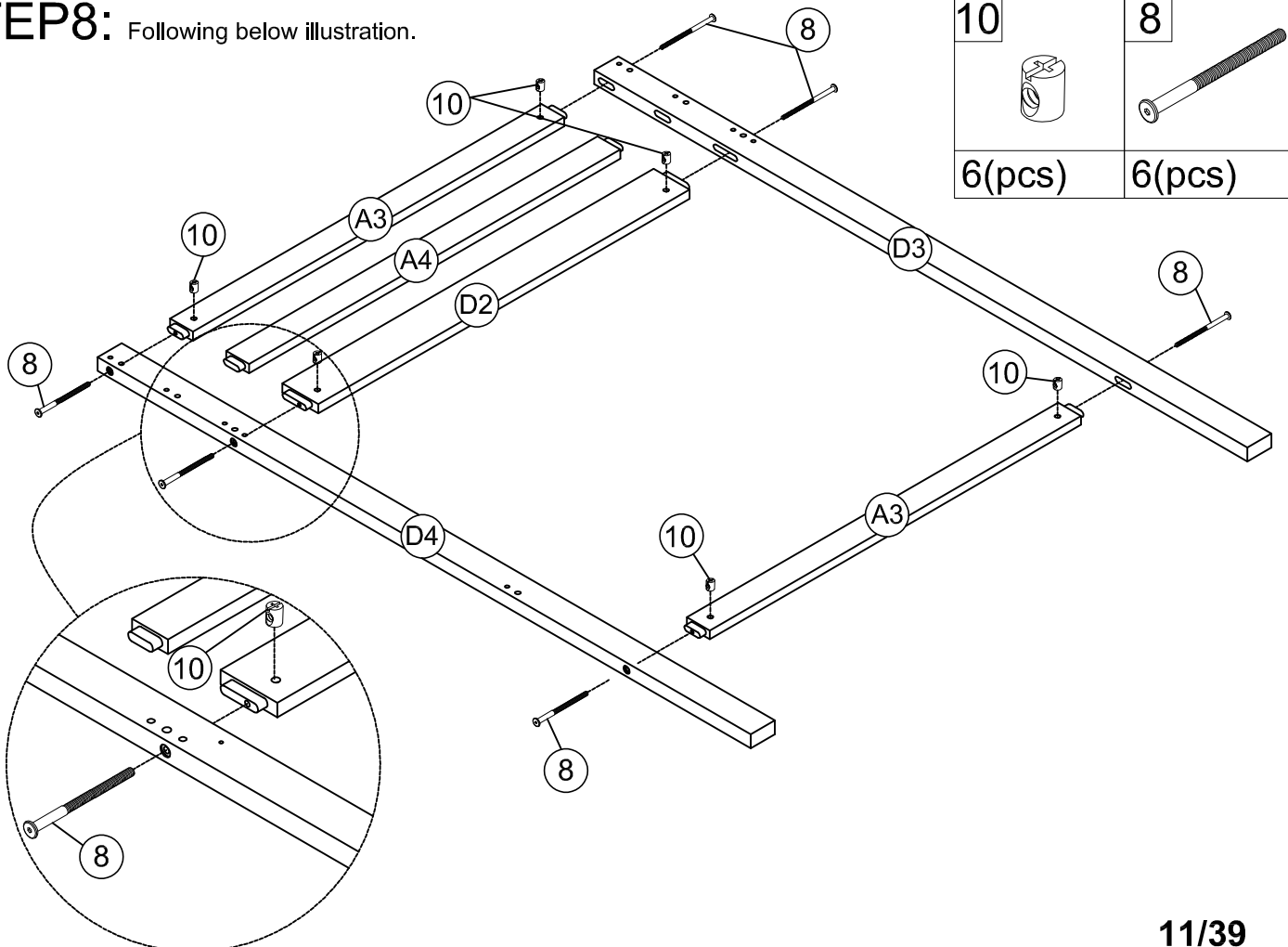

10



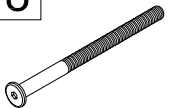

6(pcs)

8



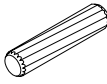

6(pcs)

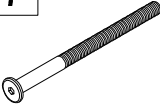
**STEP9:** Following below illustration.

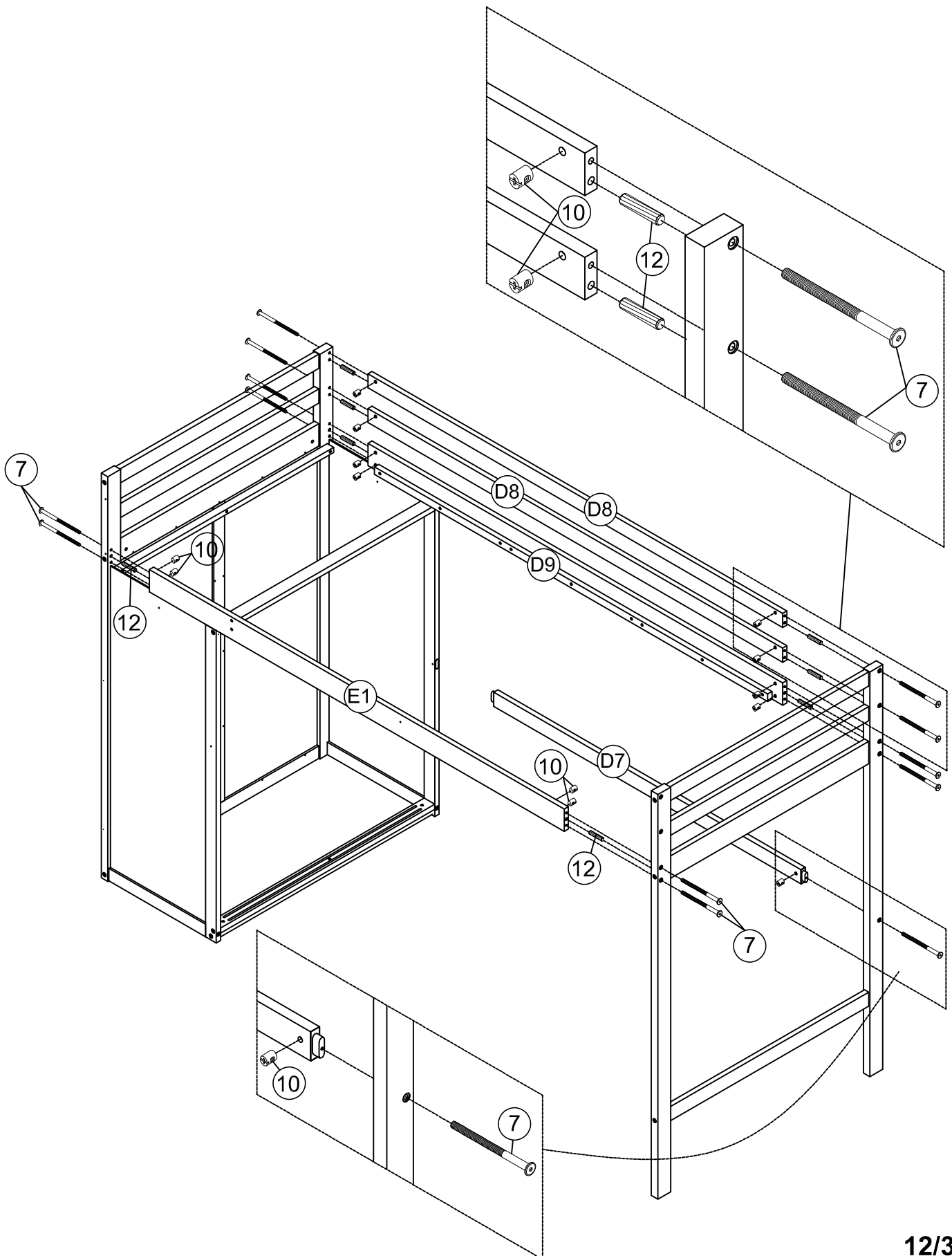
12	10	7
		
8(pcs)	13(pcs)	13(pcs)



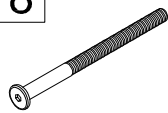
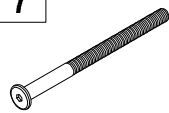
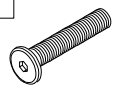
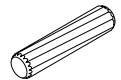

**STEP10:** Following below illustration.

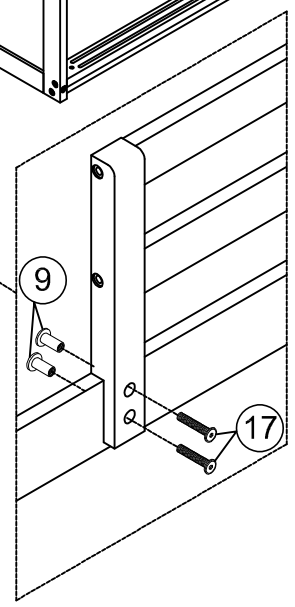
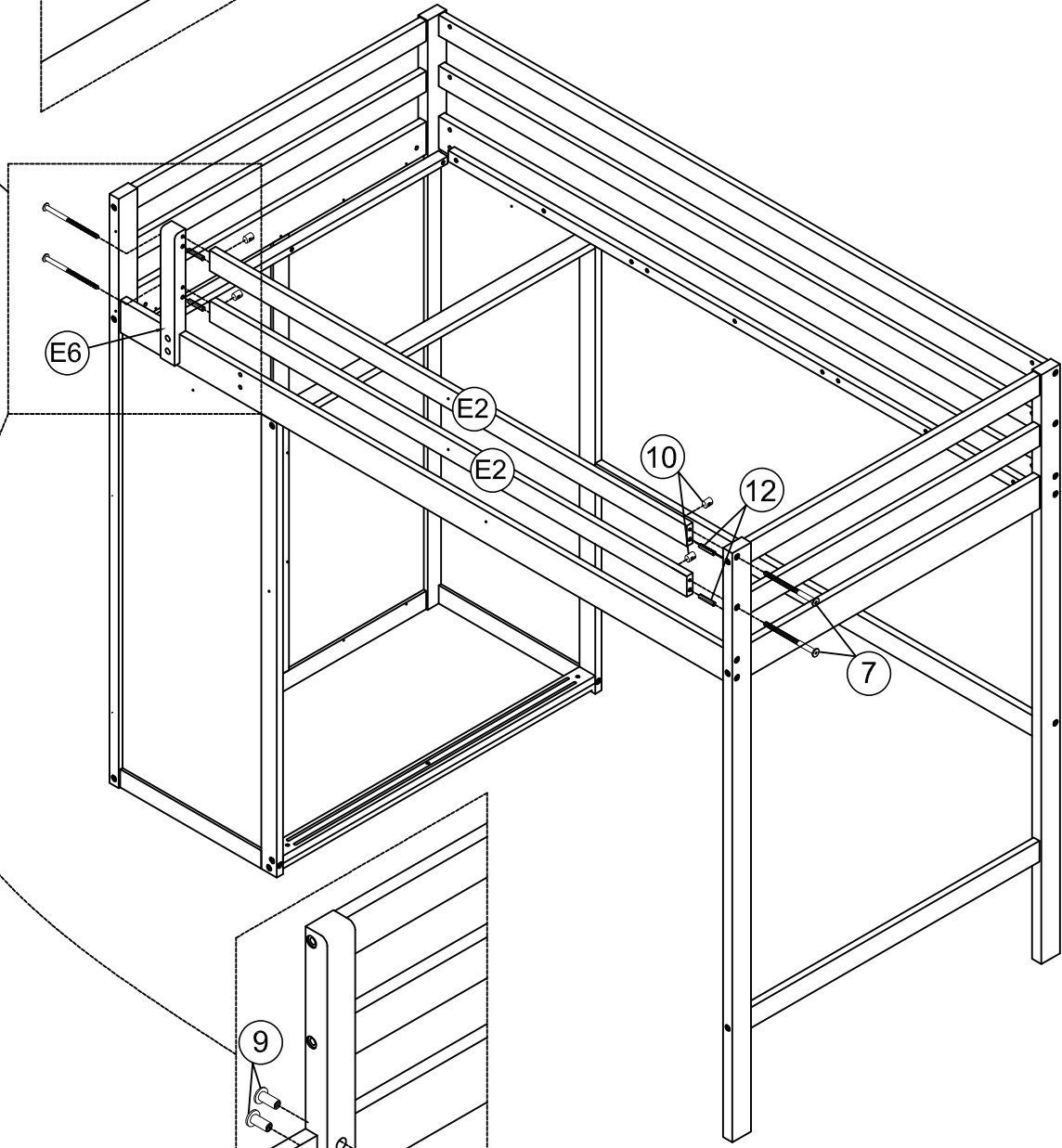
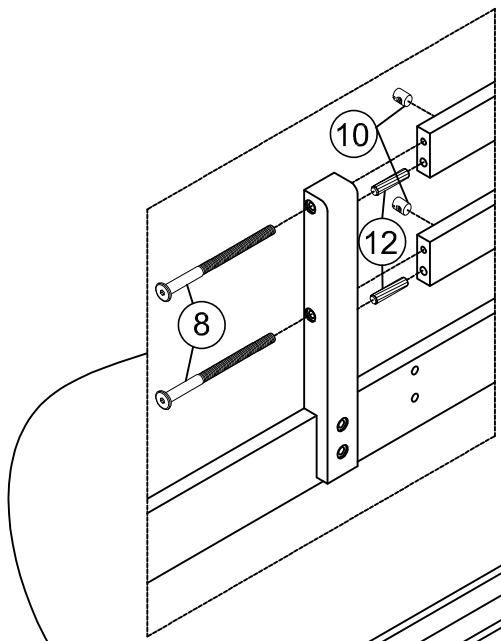
10	9	8	7
			
4(pcs)	2(pcs)	2(pcs)	2(pcs)
		17	12
			
		2(pcs)	4(pcs)



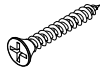

# STEP11: Following below illustration.

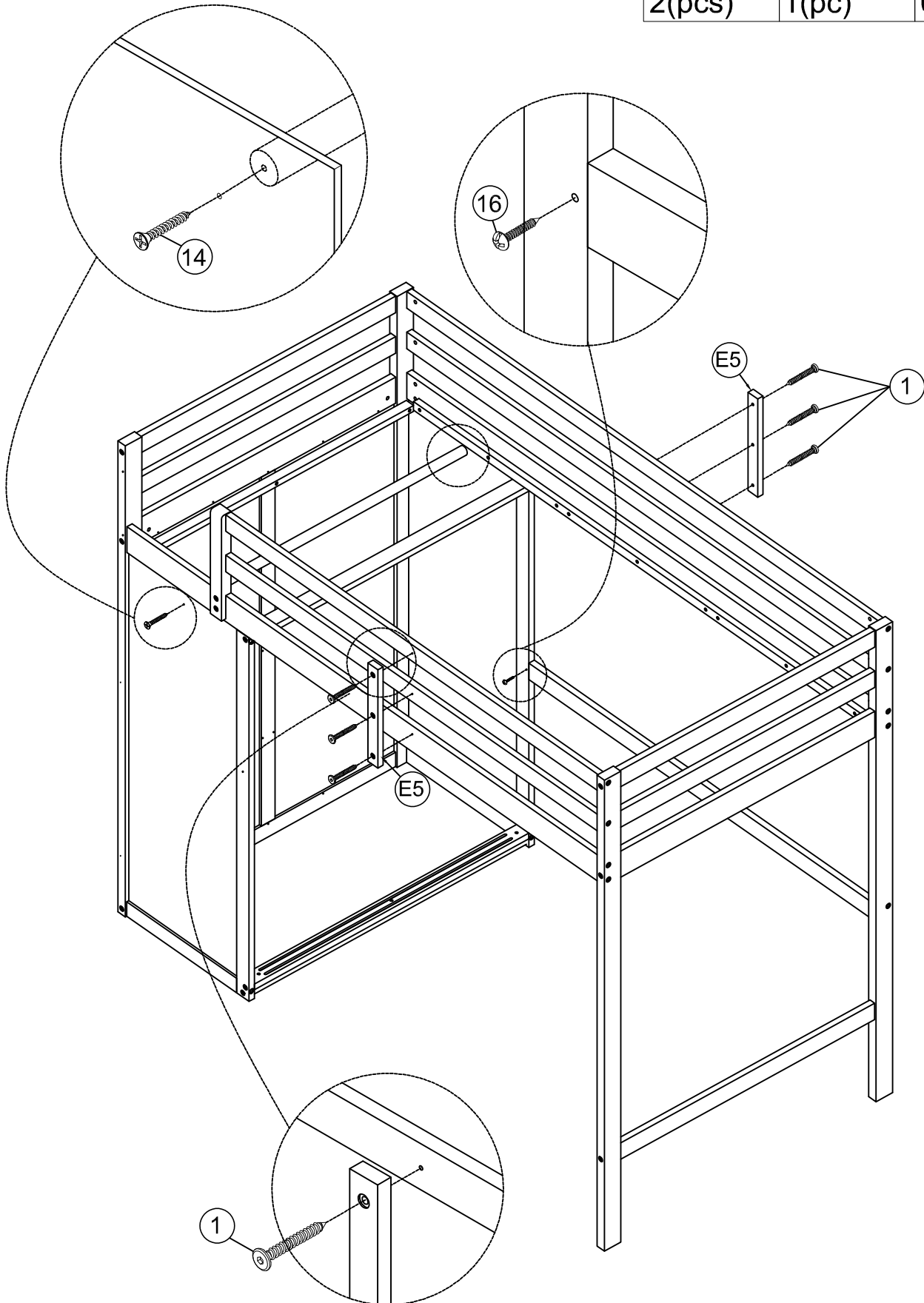
14	16	1
		
2(pcs)	1(pc)	6(pcs)



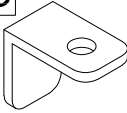

# STEP12: Following below illustration.

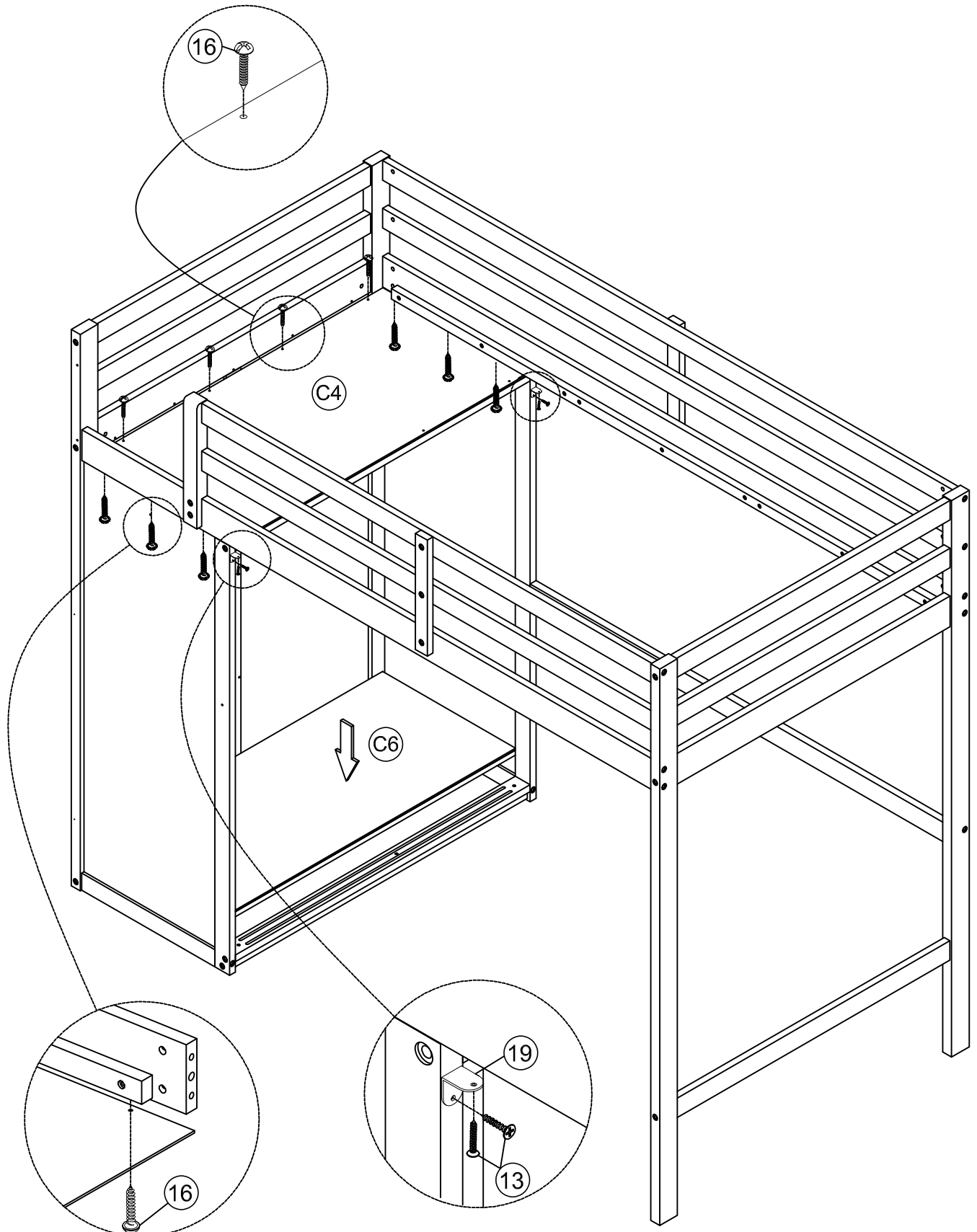
19		16		13	
2(pcs)		10(pcs)		4(pcs)	

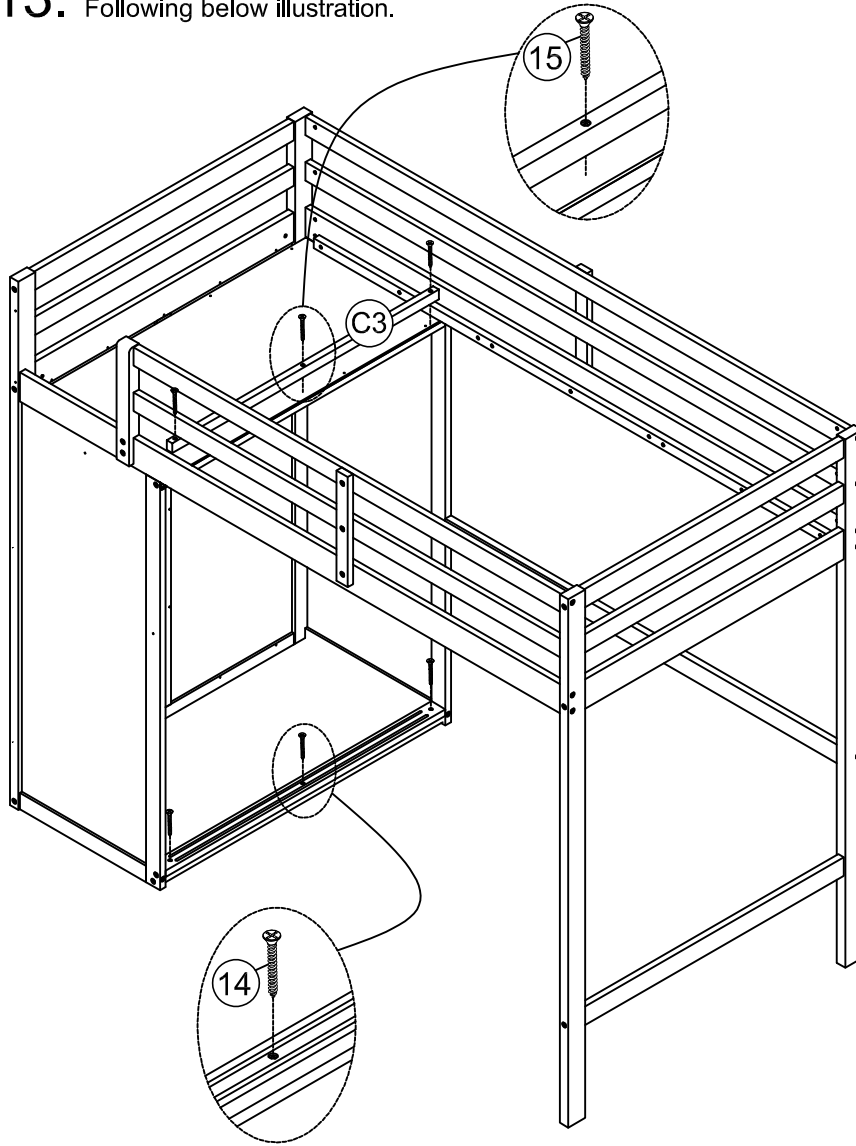

**STEP13:** Following below illustration.



15		14	
3(pcs)		3(pcs)	

**STEP14 x2:** Following below illustration.

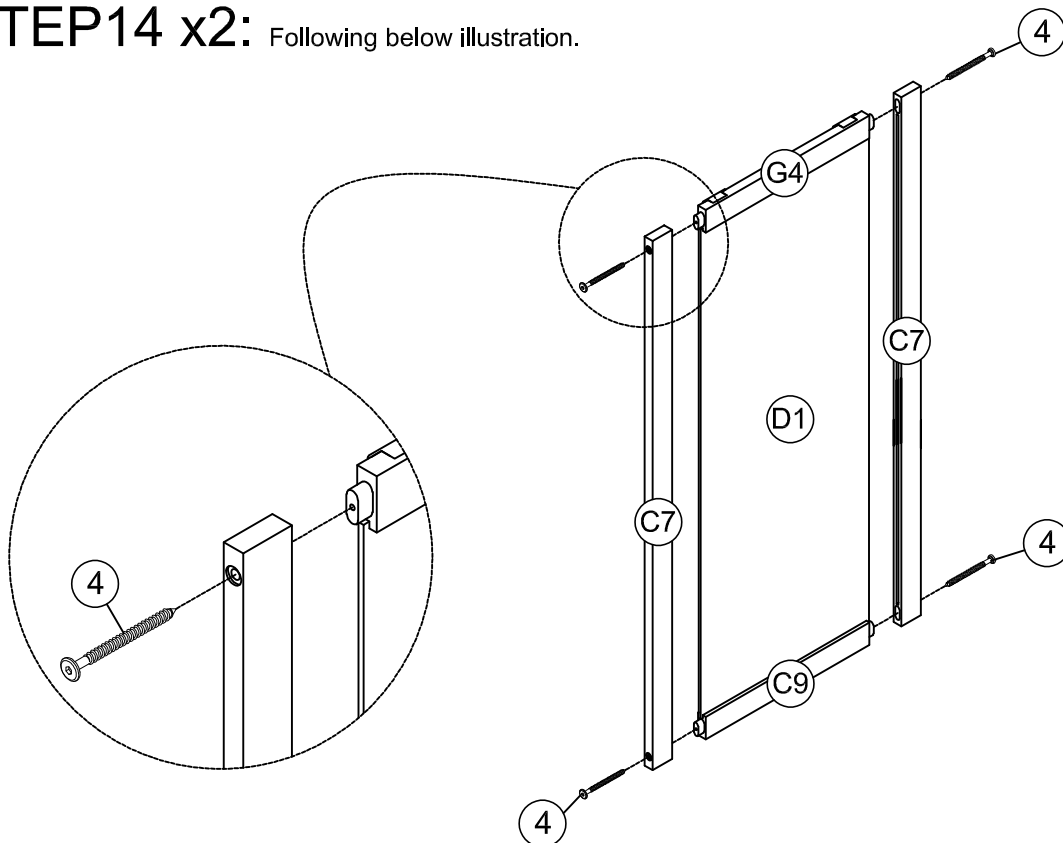

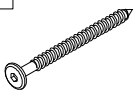
4	
8(pcs)	



**STEP 15:** Following below illustration.

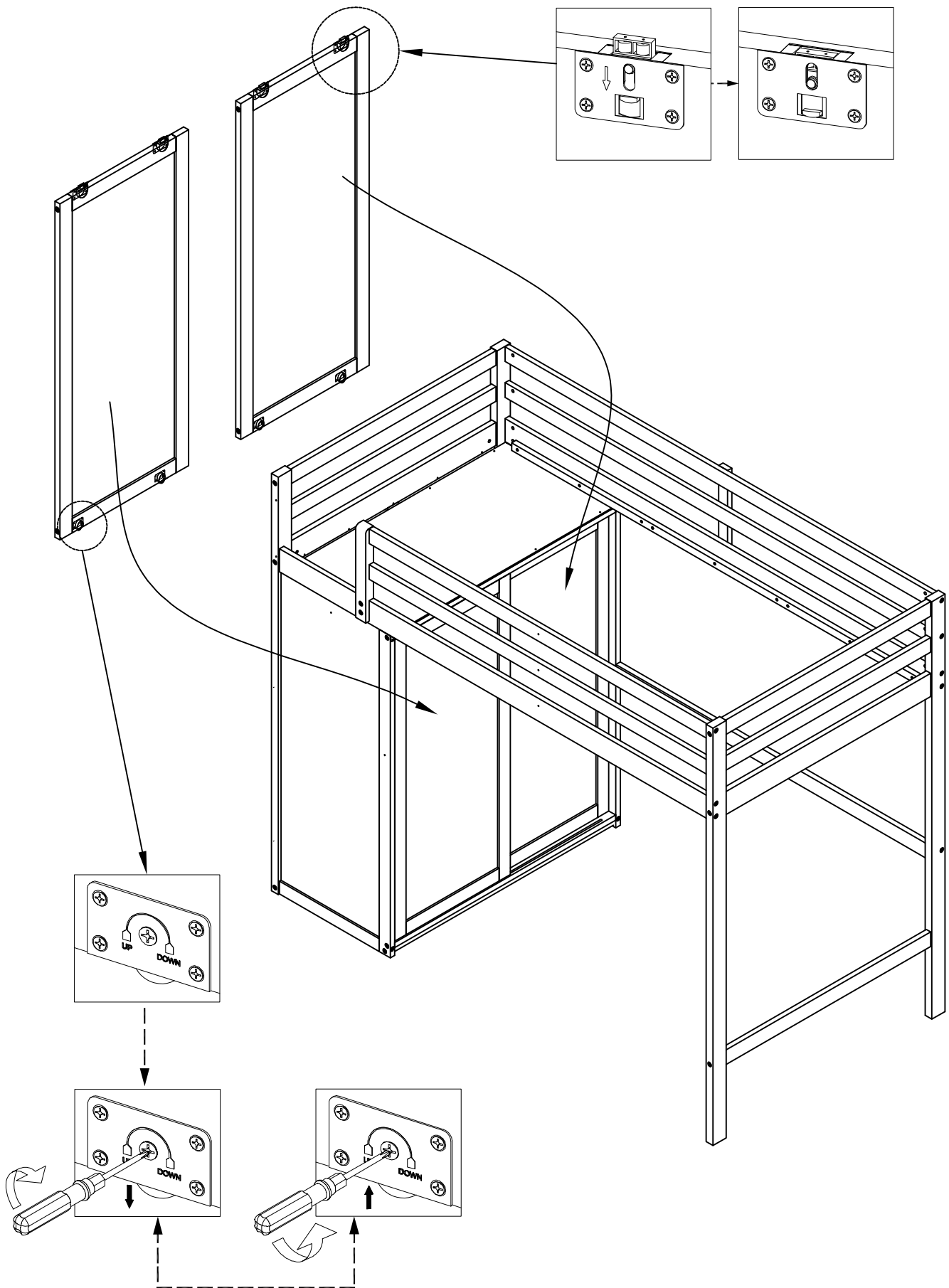

**STEP16:** Following below illustration.

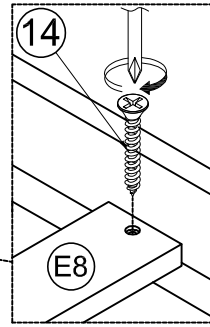
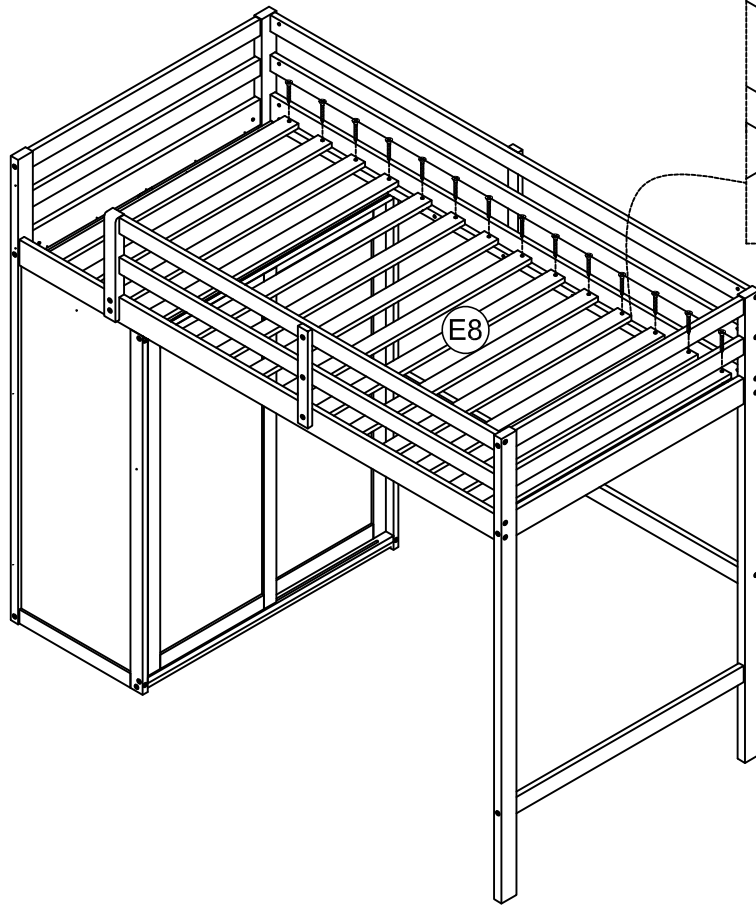

14

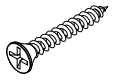

14(pcs)

**STEP17:** Following below illustration.

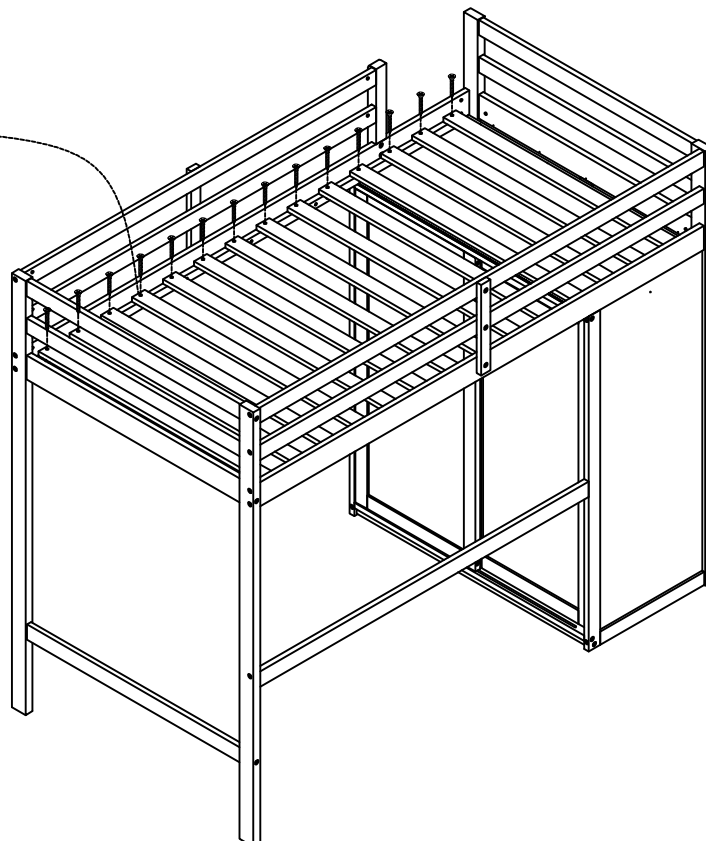
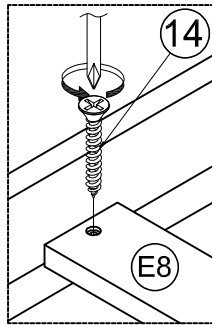

14



14(pcs)

# STEP18: Following below illustration.

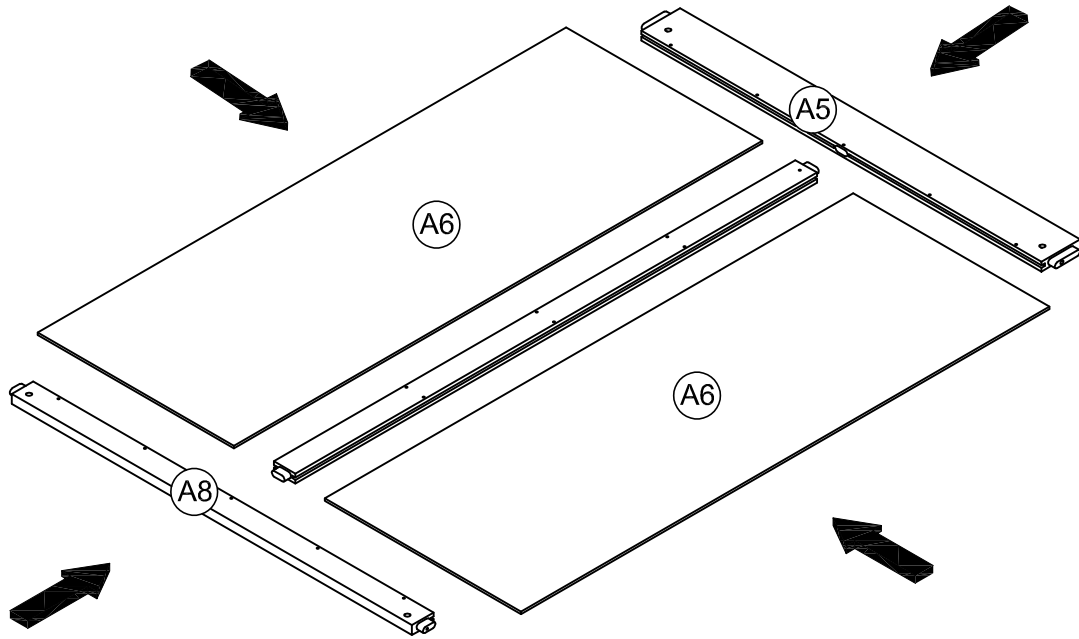

# STEP19: Following below illustration.

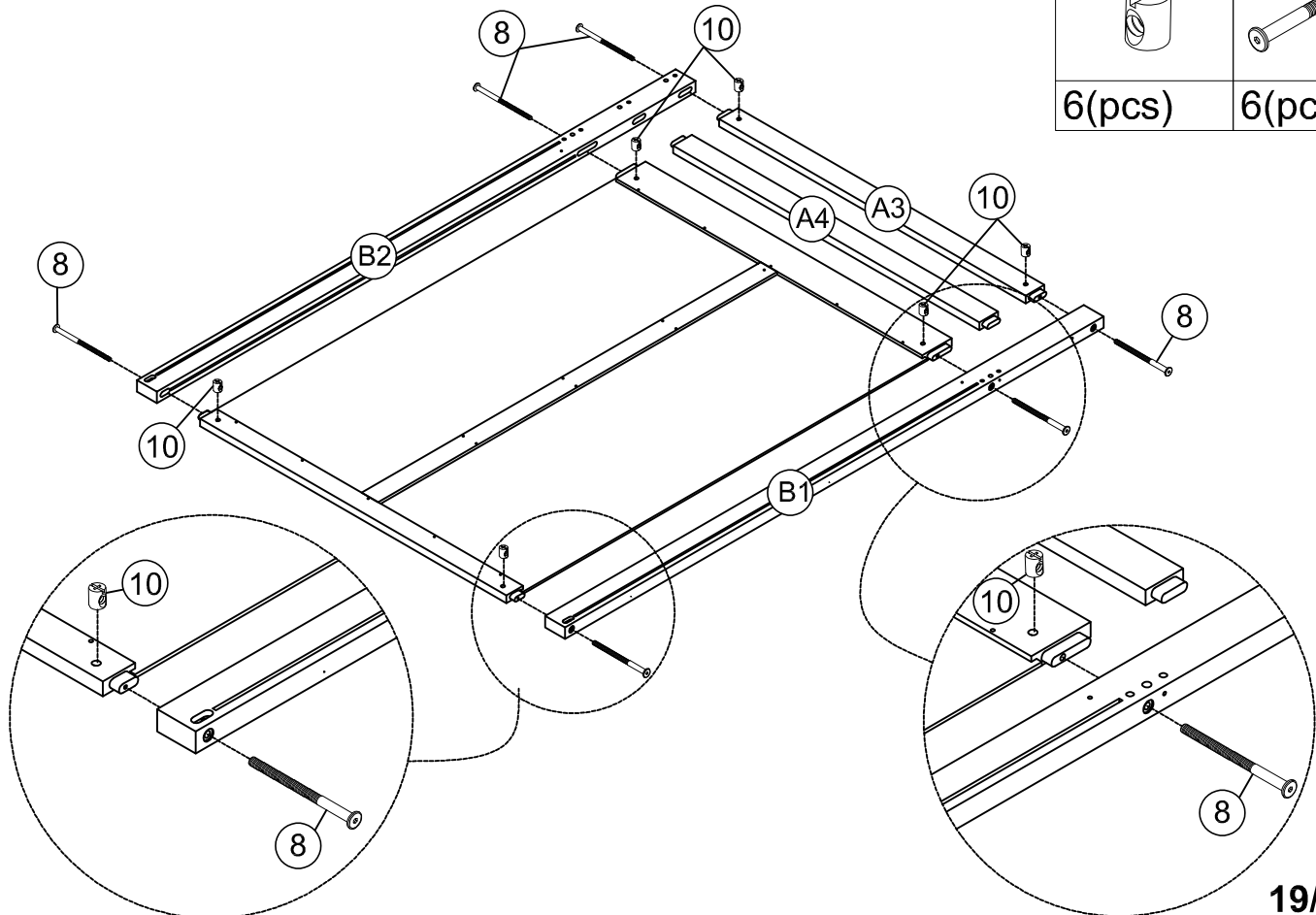

**STEP20:** Following below illustration.

16



16(pcs)

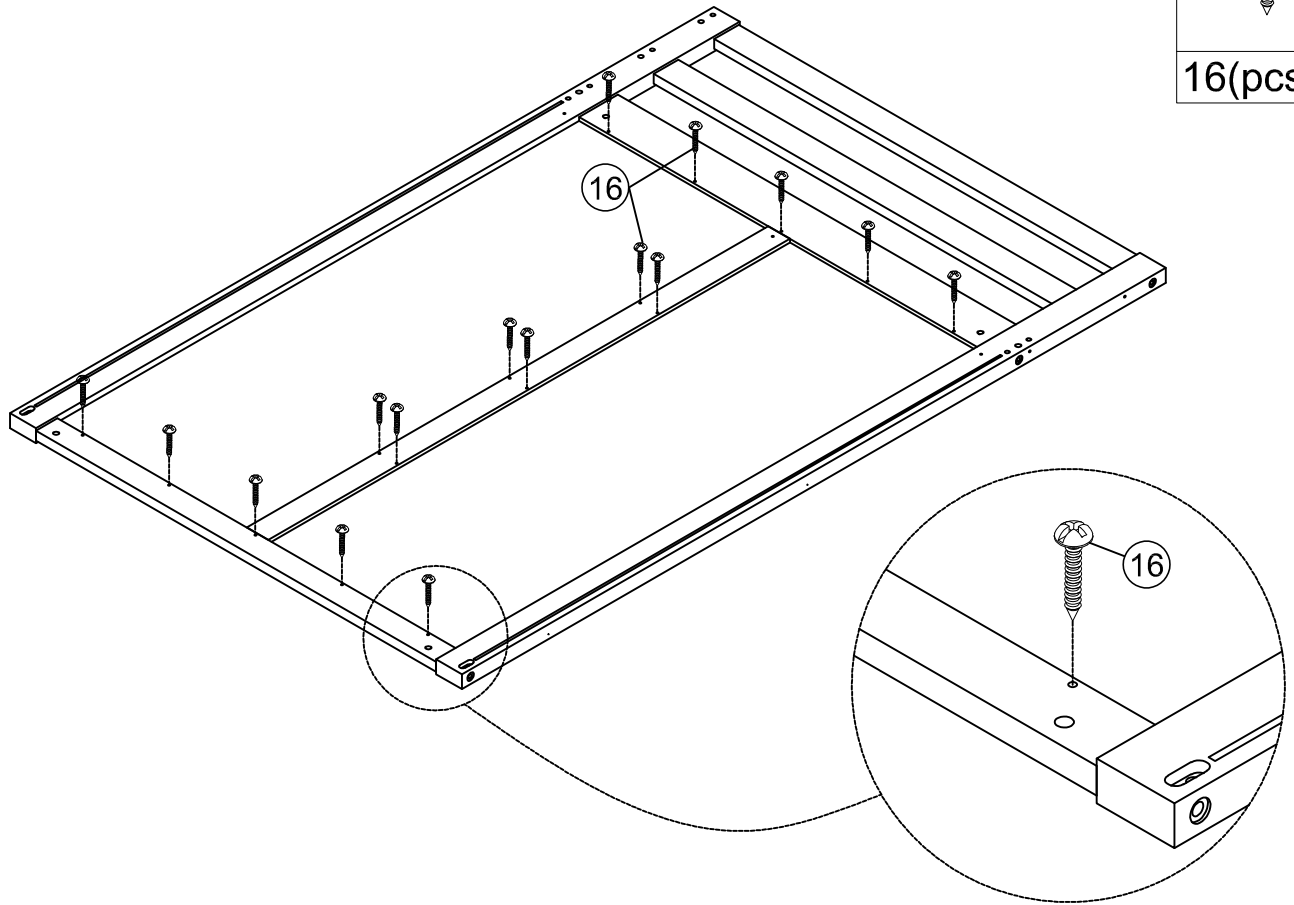

**STEP21** Following below illustration.

15



3(pcs)

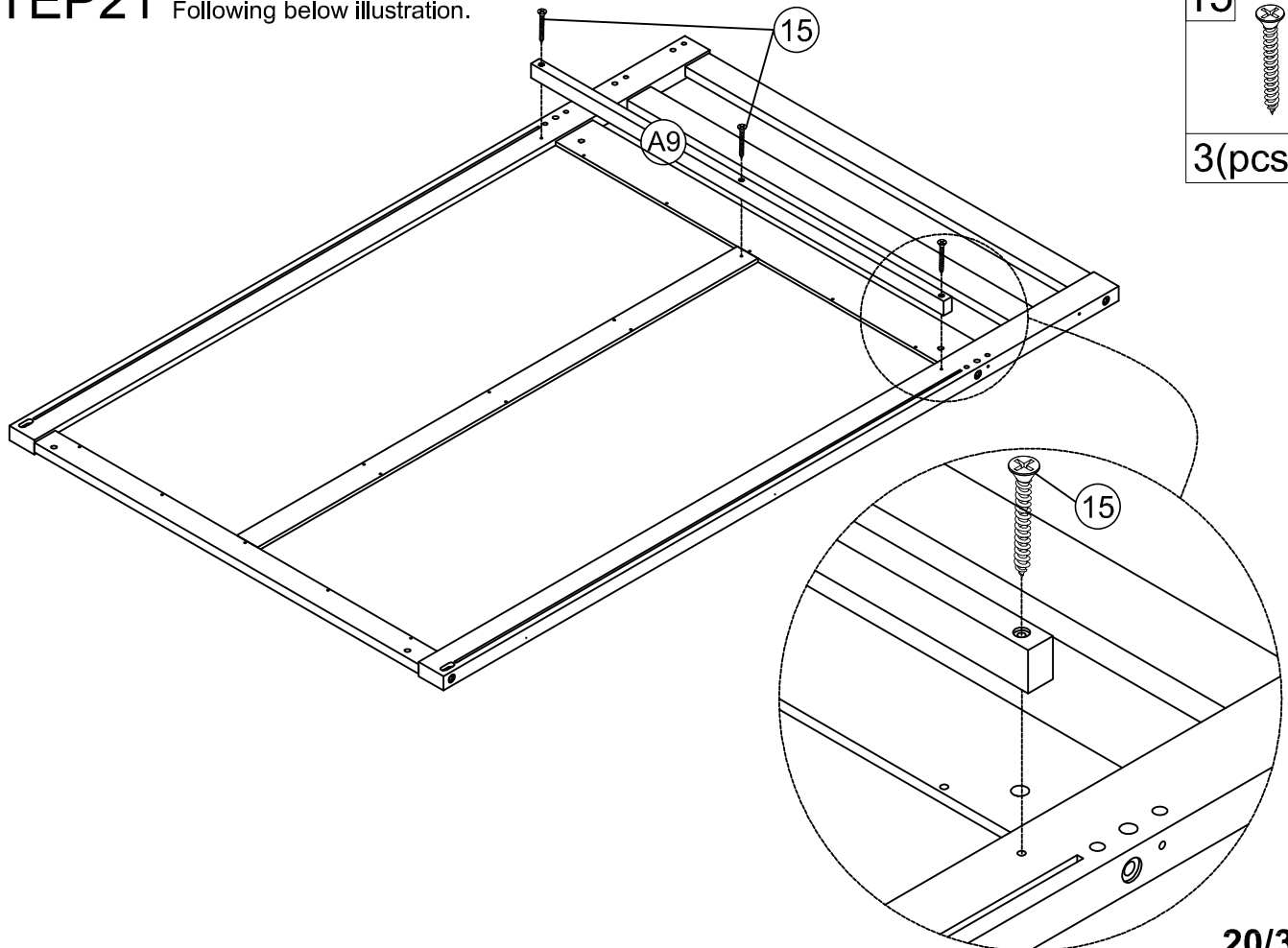

**STEP22:** Following below illustration.

2

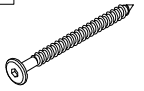

2(pcs)

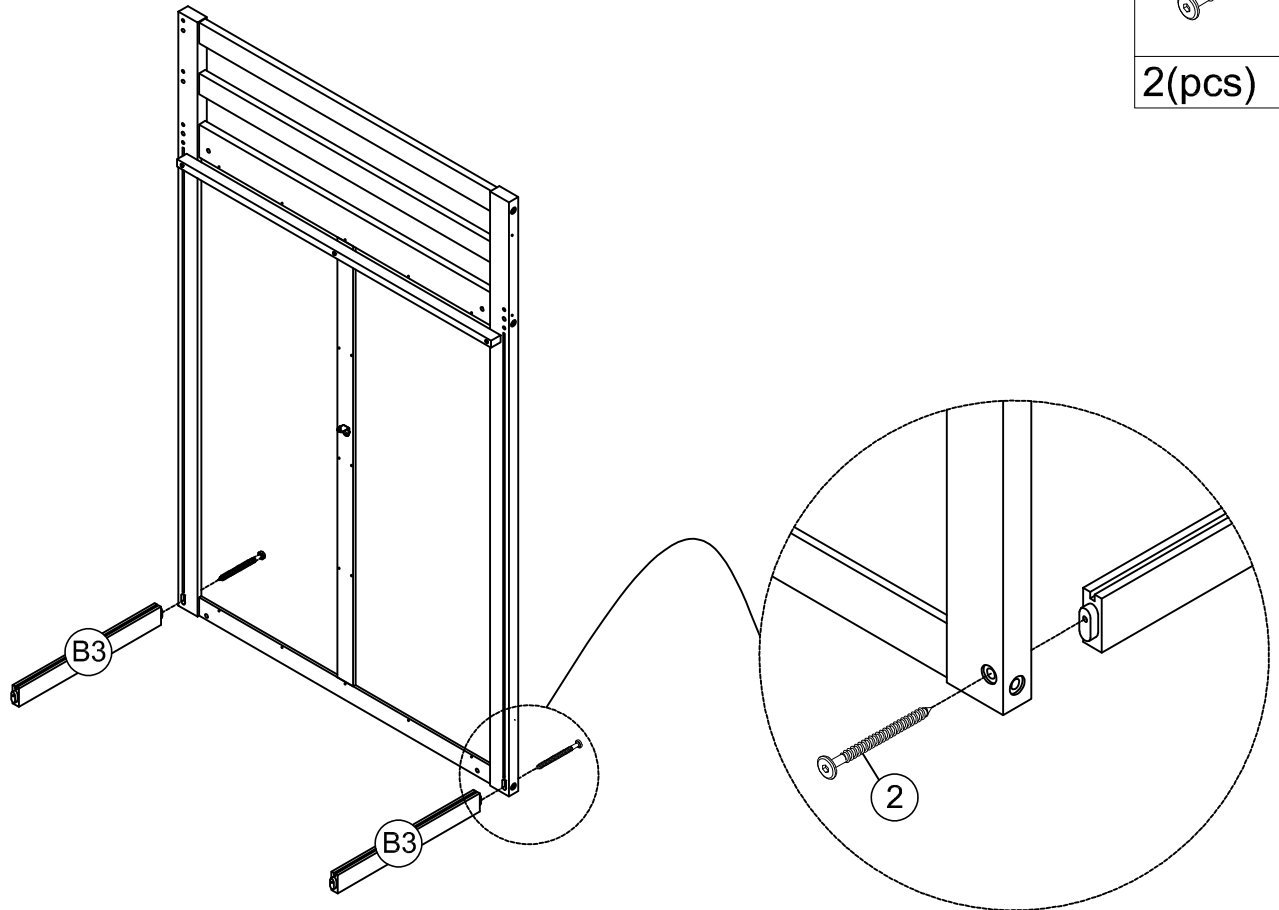

**STEP23:** Following below illustration.

11

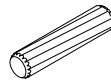

4(pcs)

2



6(pcs)



**STEP24:** Following below illustration.

4

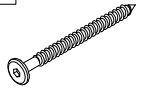

2(pcs)

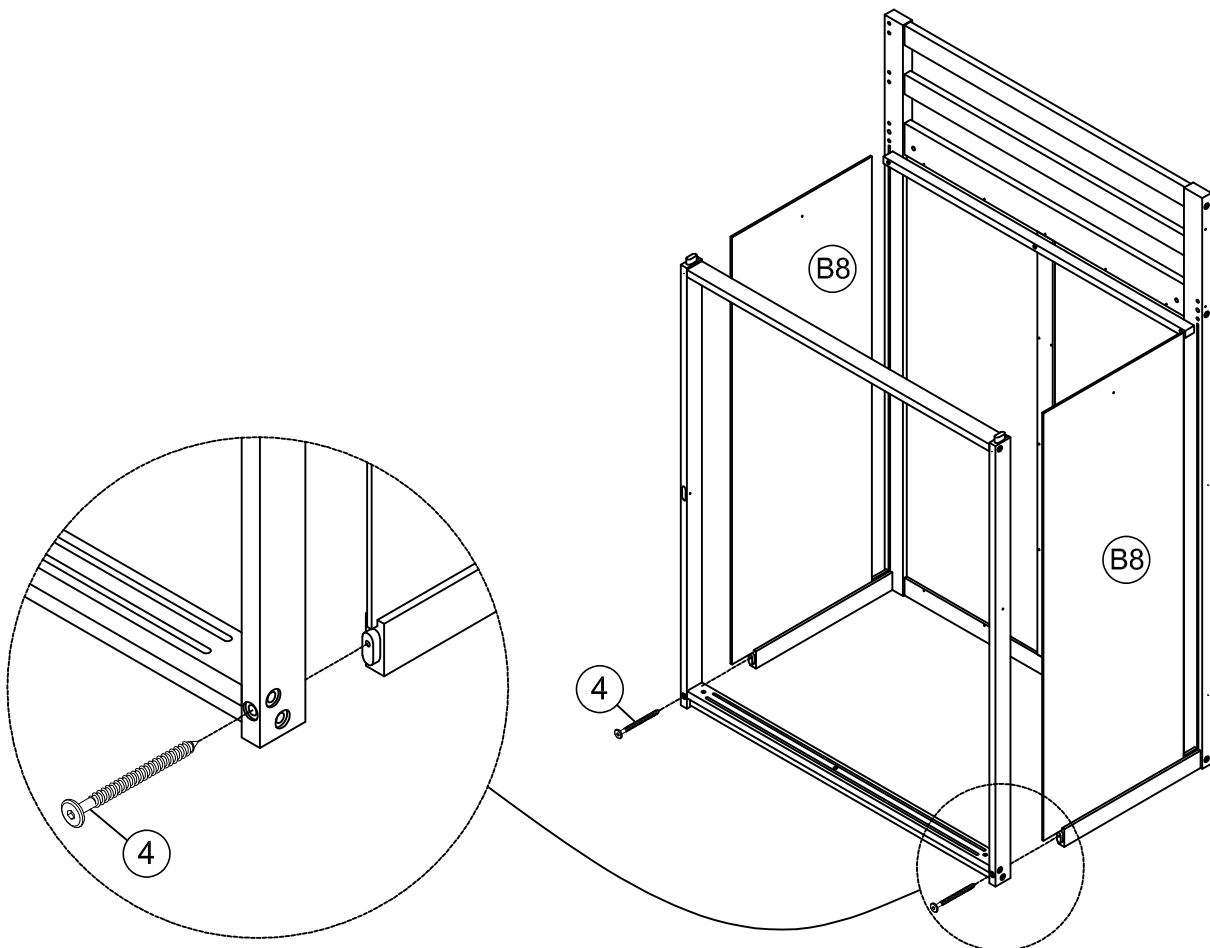

**STEP25:** Following below illustration.

10



6(pcs)

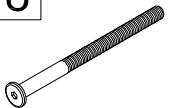

8

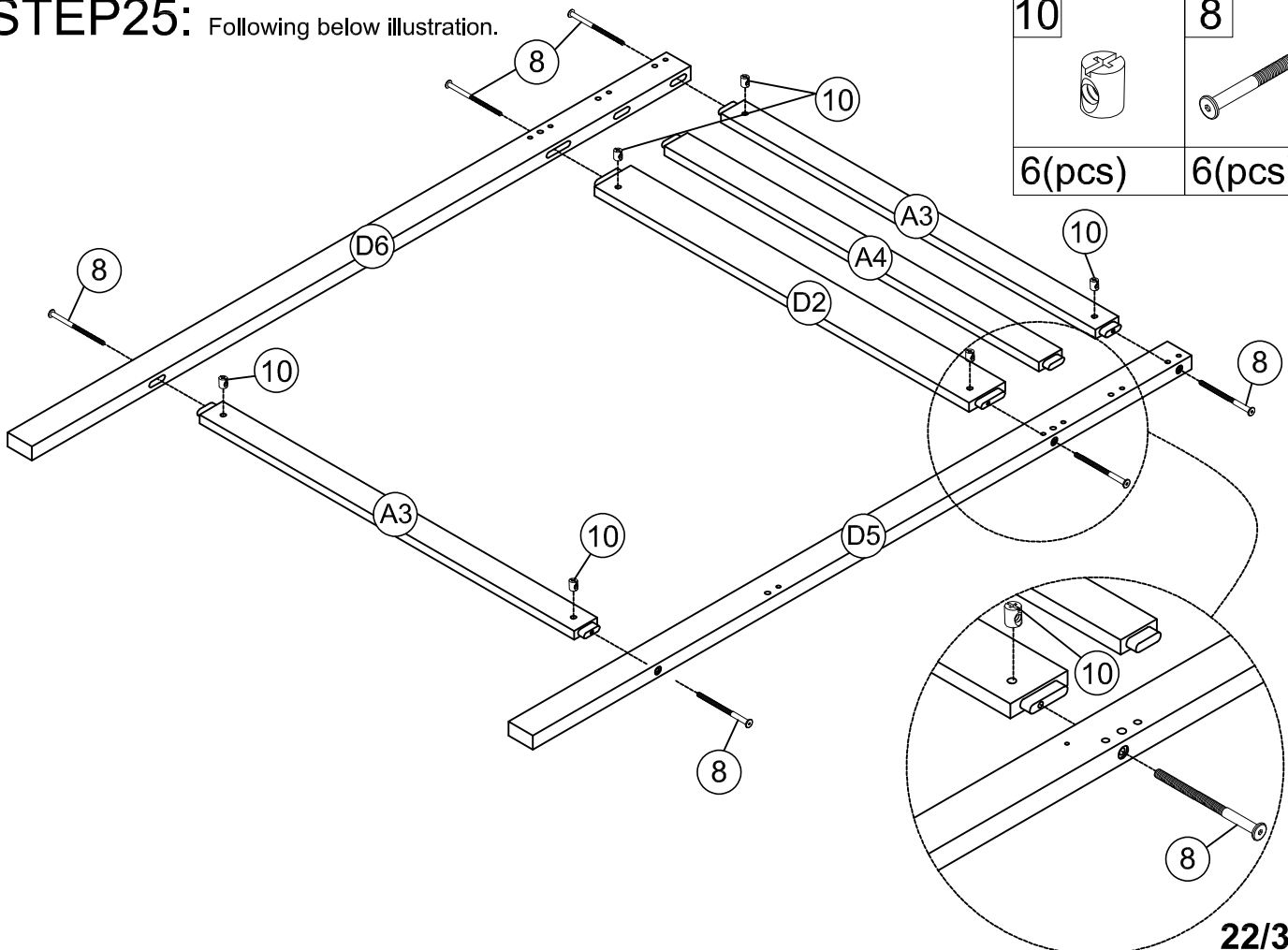

6(pcs)



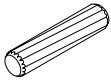

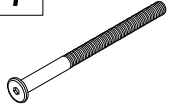
# STEP26: Following below illustration.

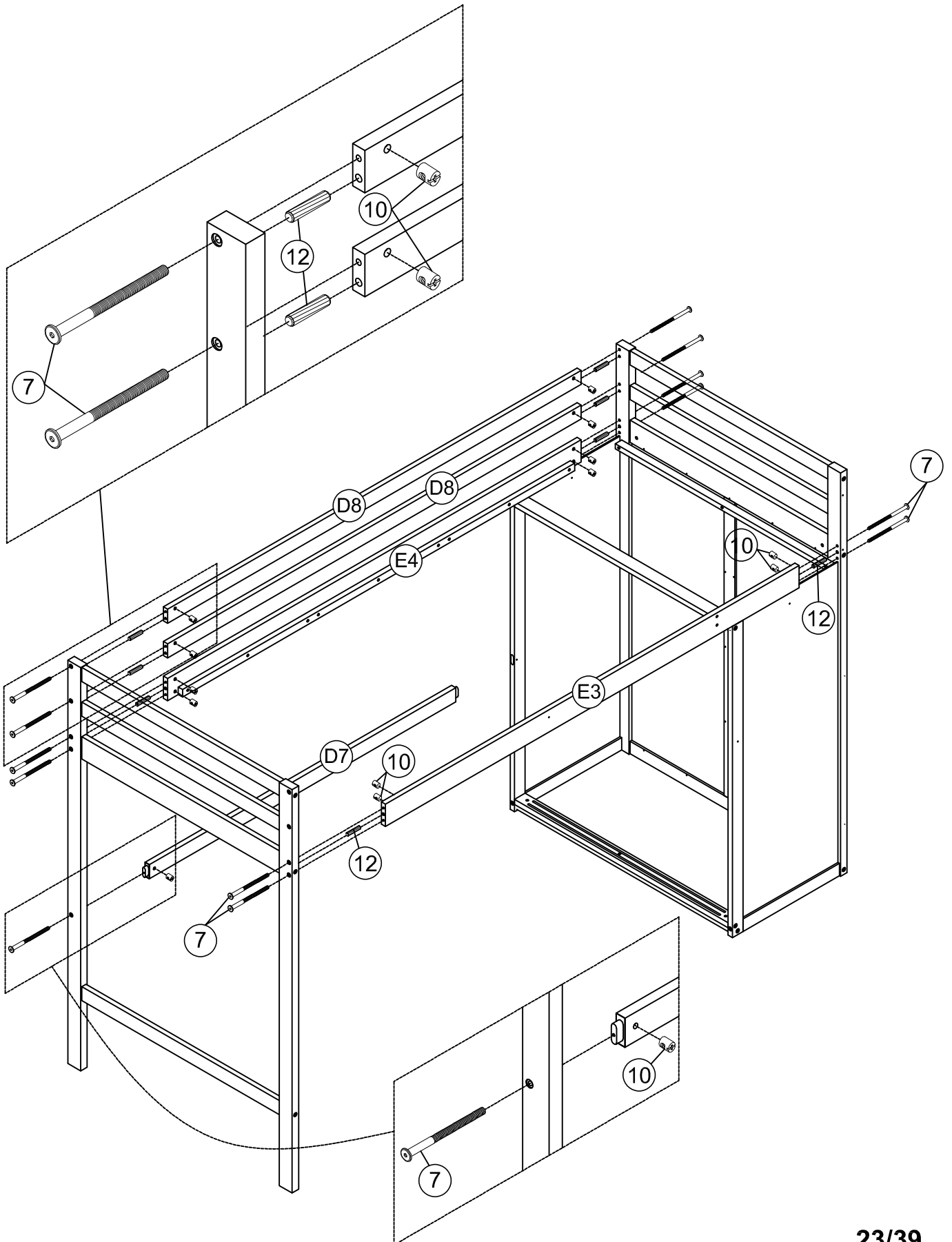
12	10	7
		
8(pcs)	13(pcs)	13(pcs)



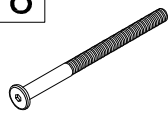
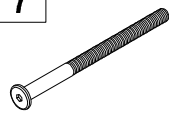
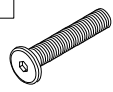
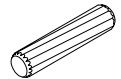

**STEP27:** Following below illustration.

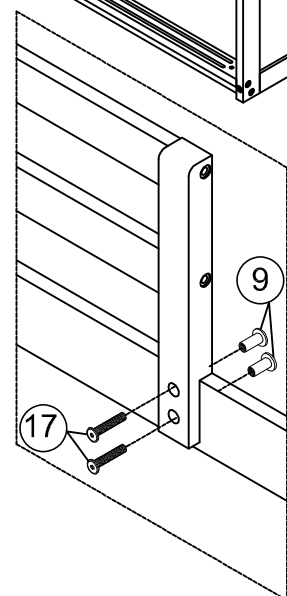
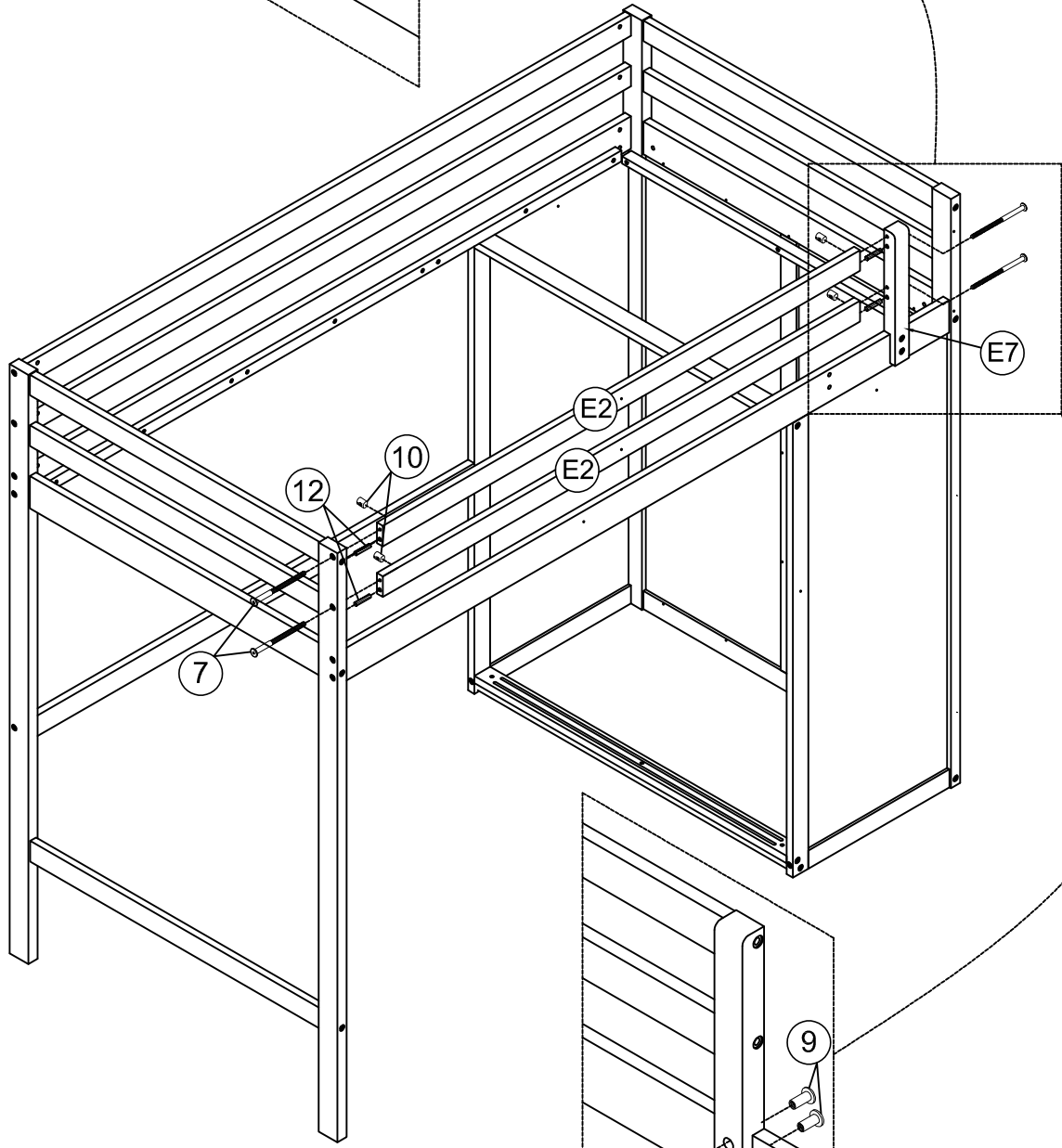
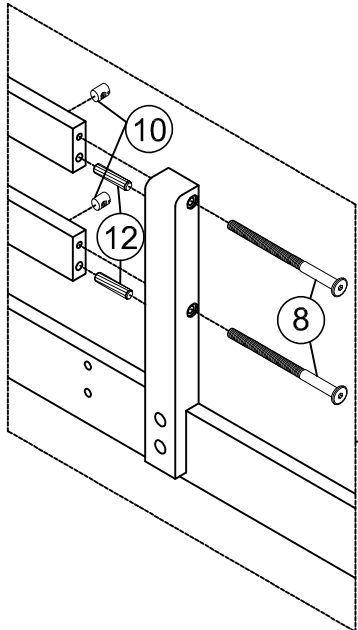
10	9	8	7
			
4(pcs)	2(pcs)	2(pcs)	2(pcs)
		17	12
			
		2(pcs)	4(pcs)





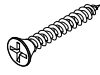

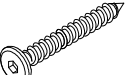
# STEP28: Following below illustration.

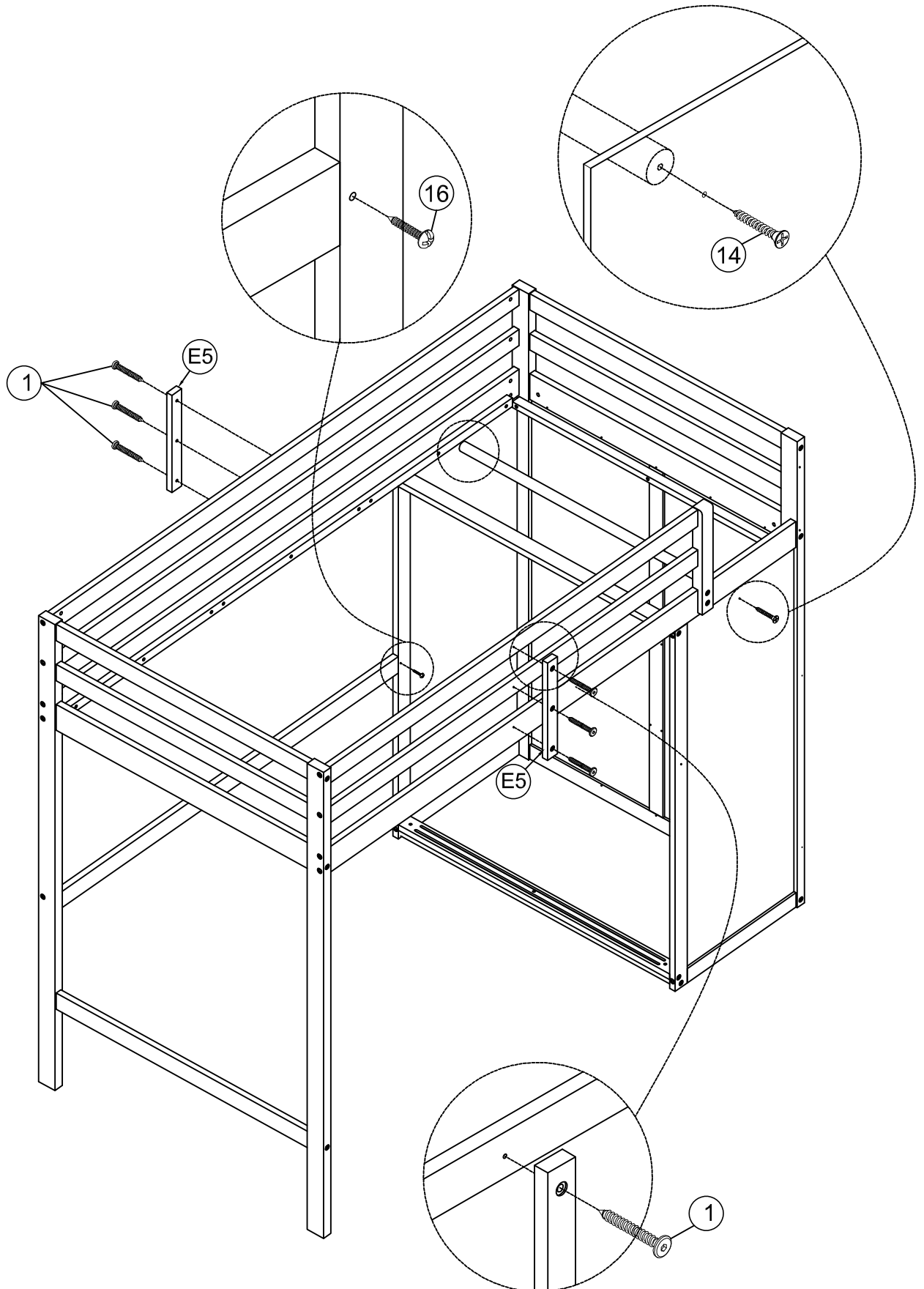
14	16	1
		
2(pcs)	1(pc)	6(pcs)

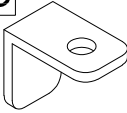

# STEP29: Following below illustration.

19	16	13
		
2(pcs)	10(pcs)	4(pcs)

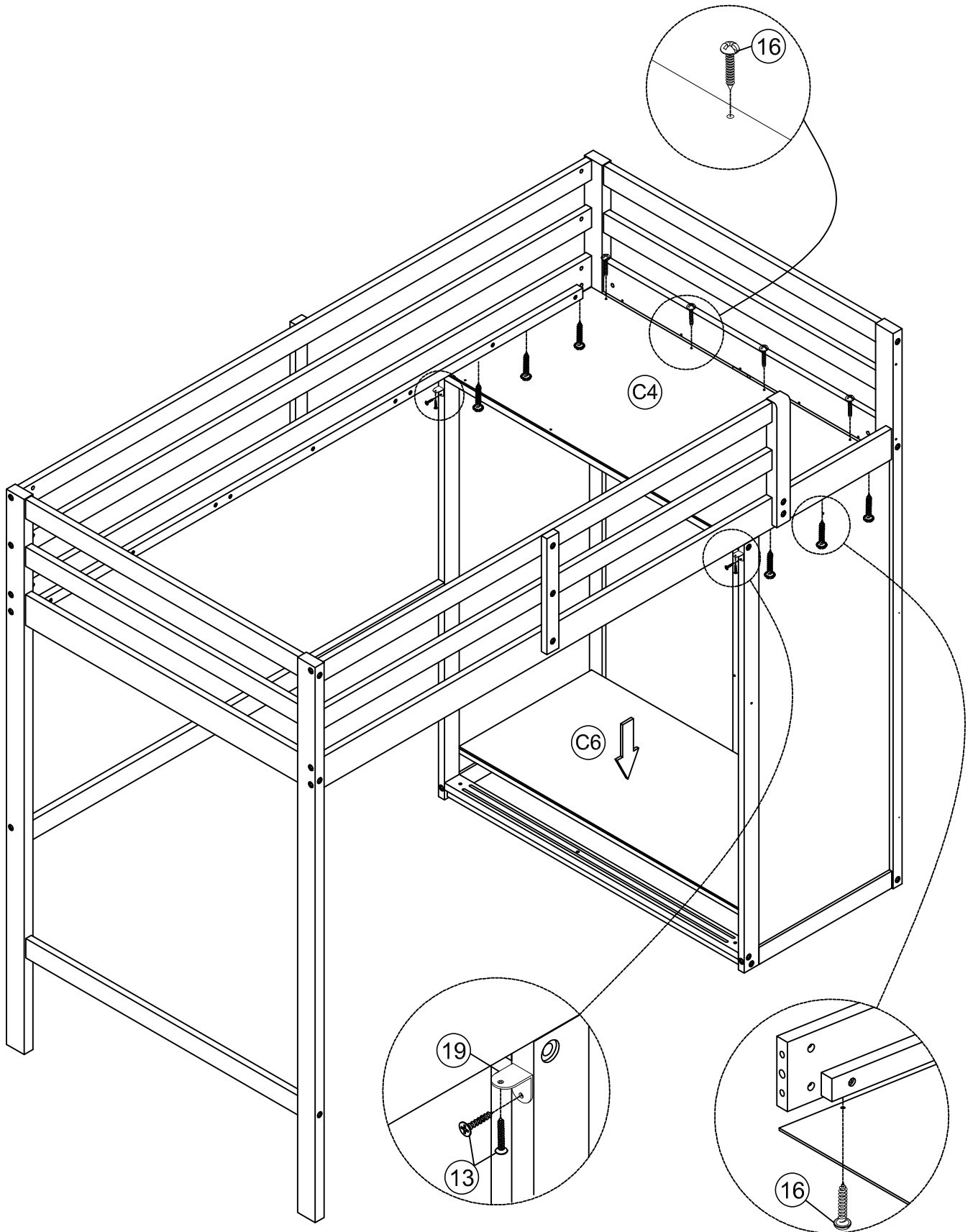

**STEP30:** Following below illustration.

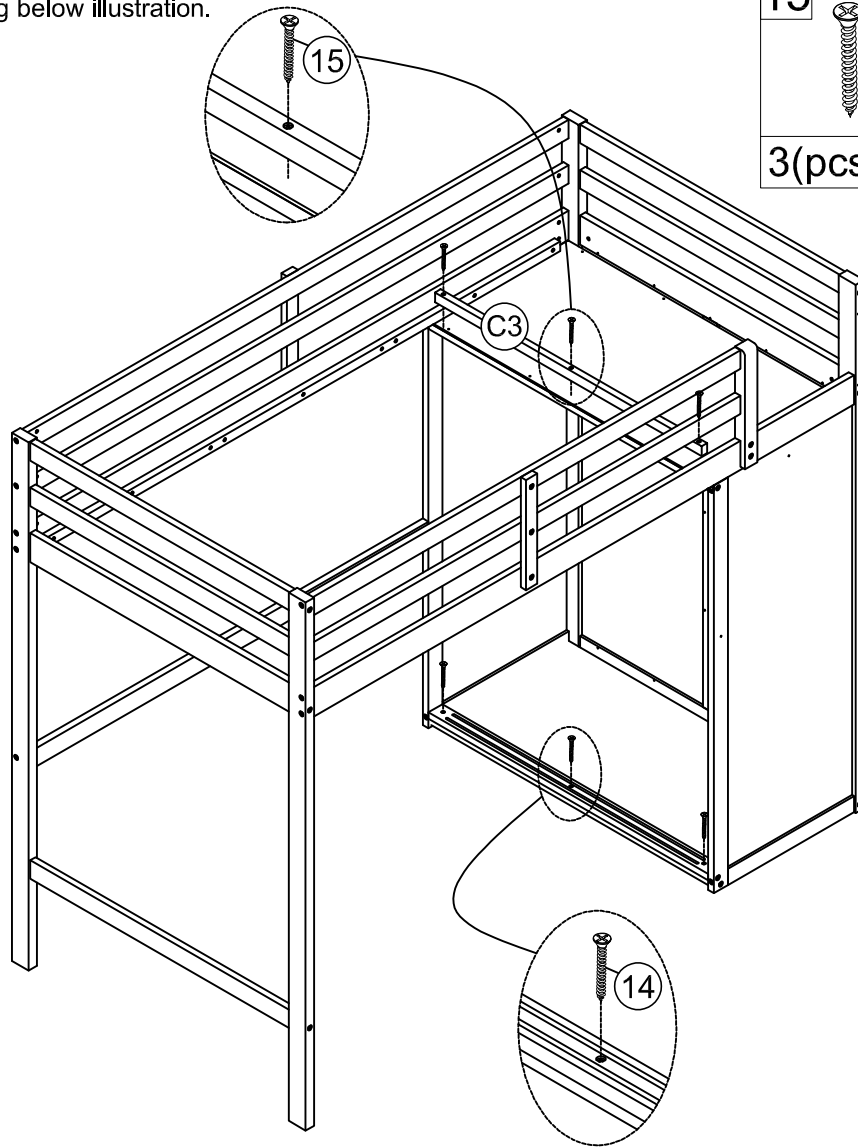

**STEP31 x2:** Following below illustration.

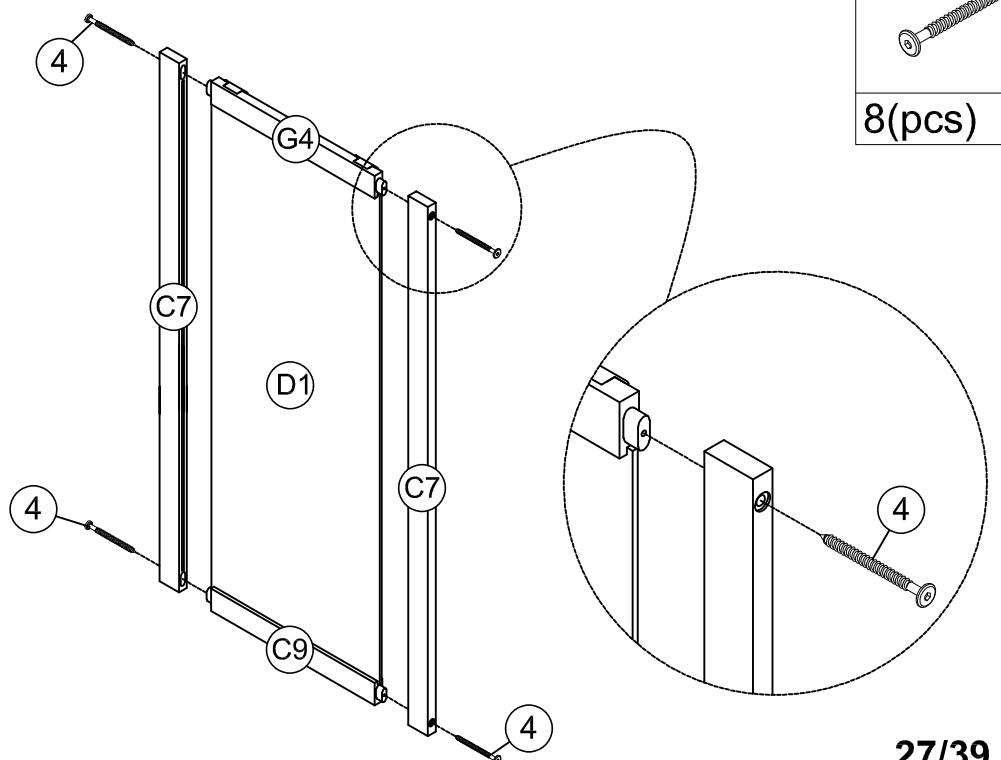

**STEP32:** Following below illustration.

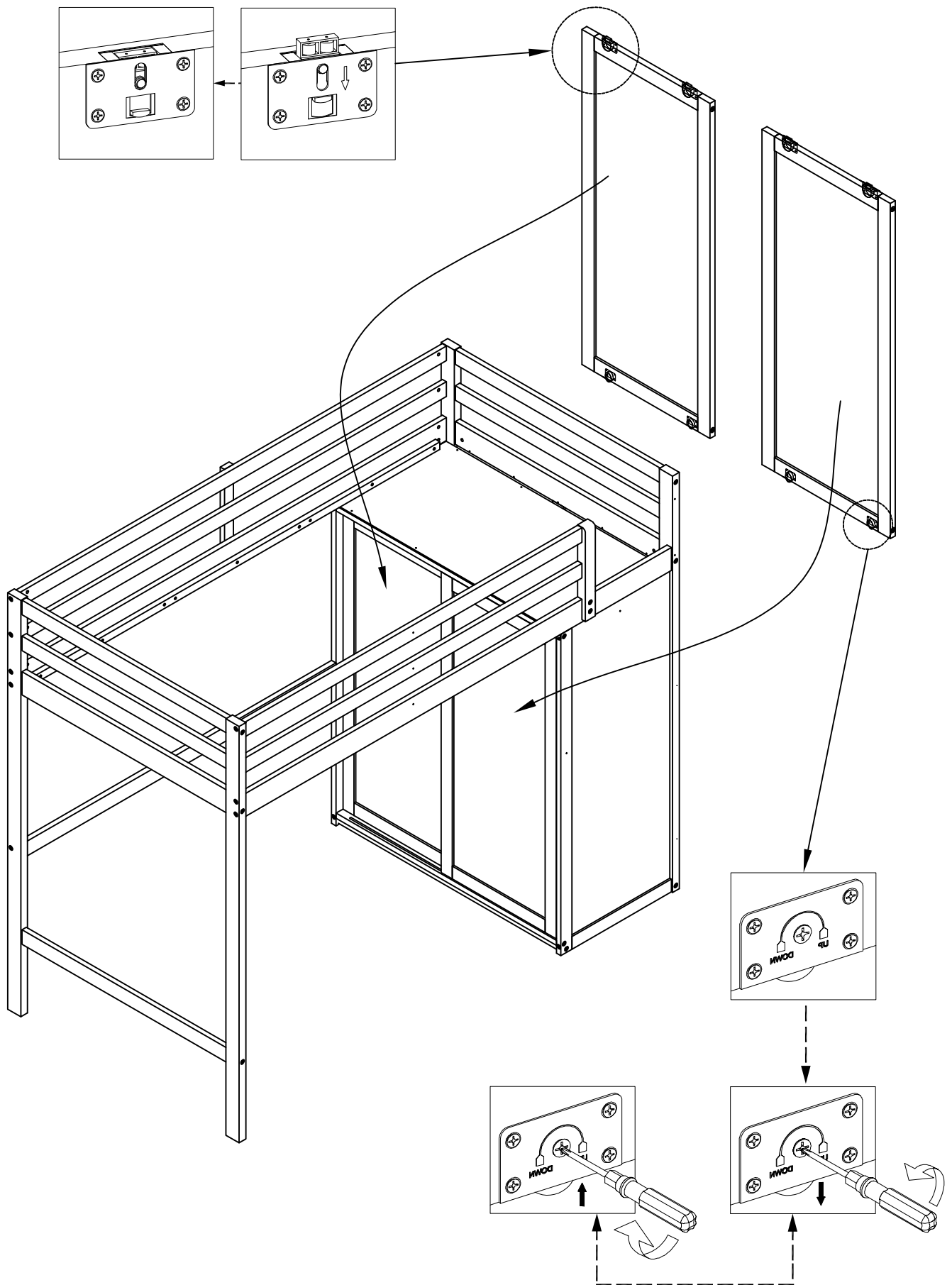

**STEP33:** Following below illustration.

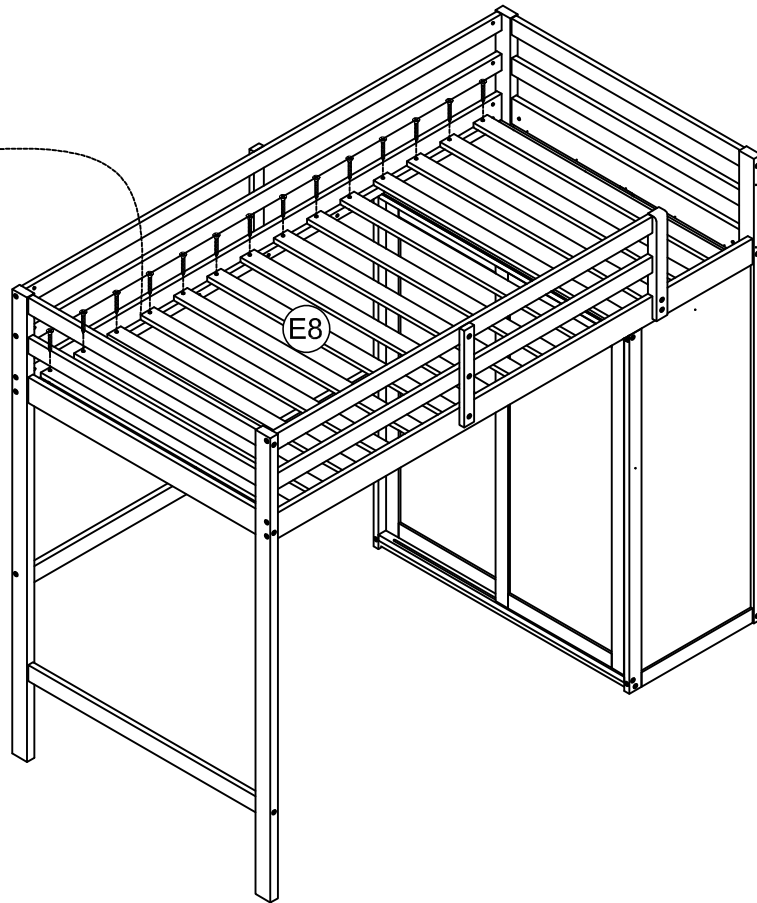
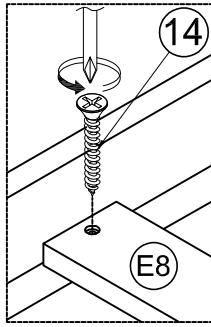

14



14(pcs)

**STEP34:** Following below illustration.

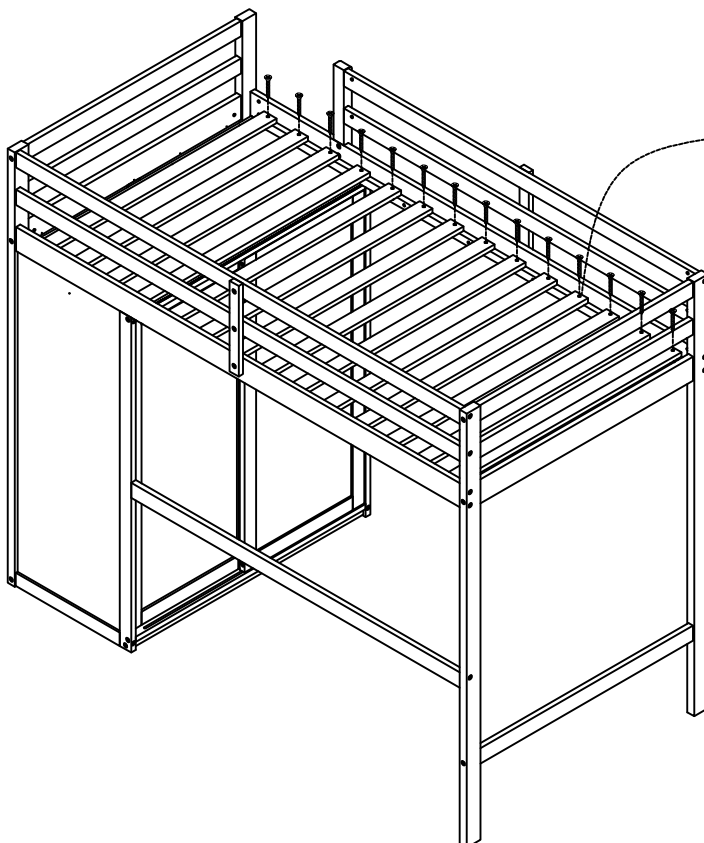
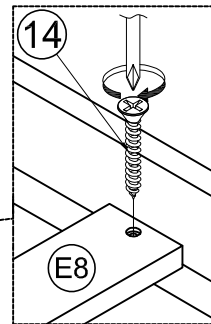

14



14(pcs)

**STEP35:** Following below illustration.

5

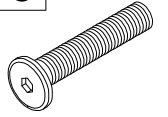

4(pcs)

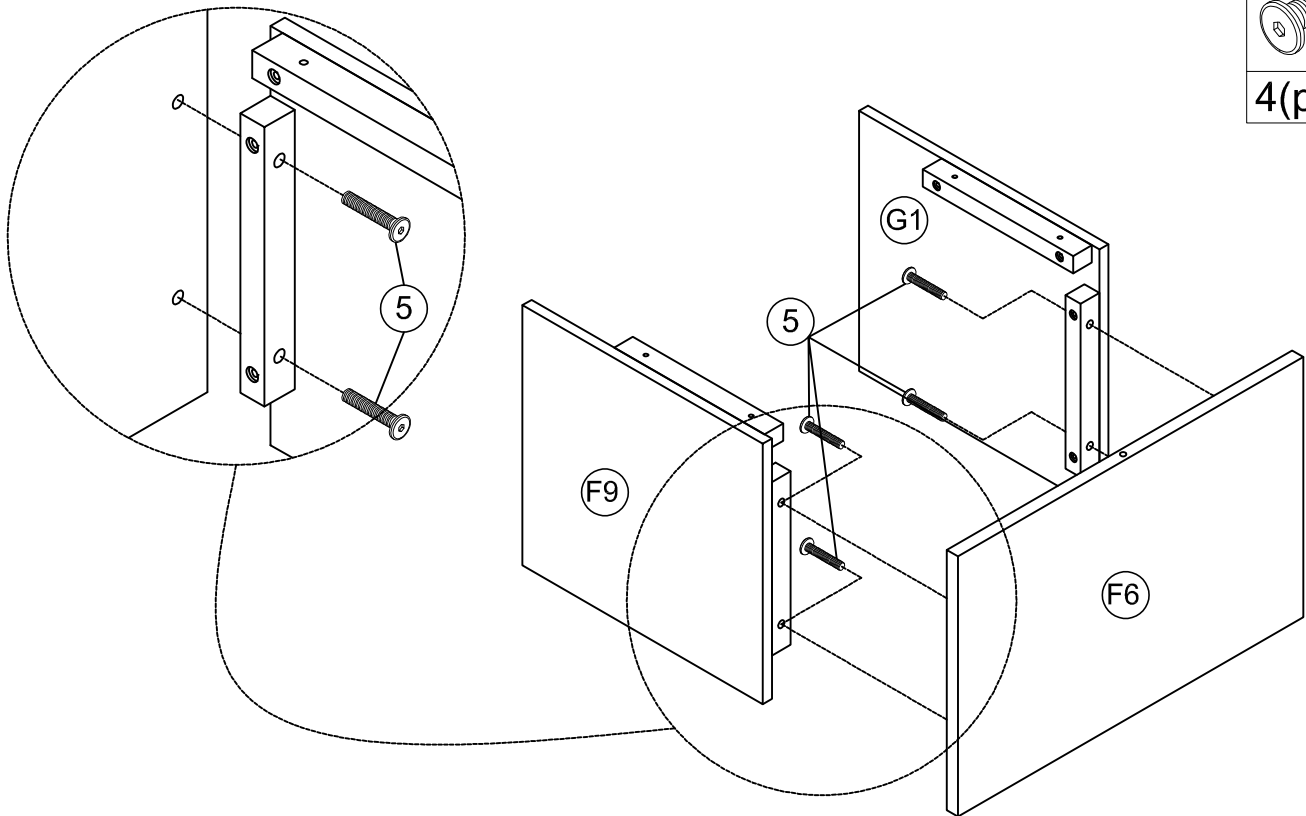

**STEP36:** Following below illustration.

10



3(pcs)

6

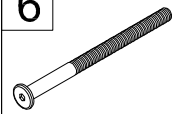

3(pcs)

1

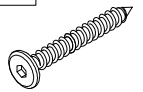

4(pcs)

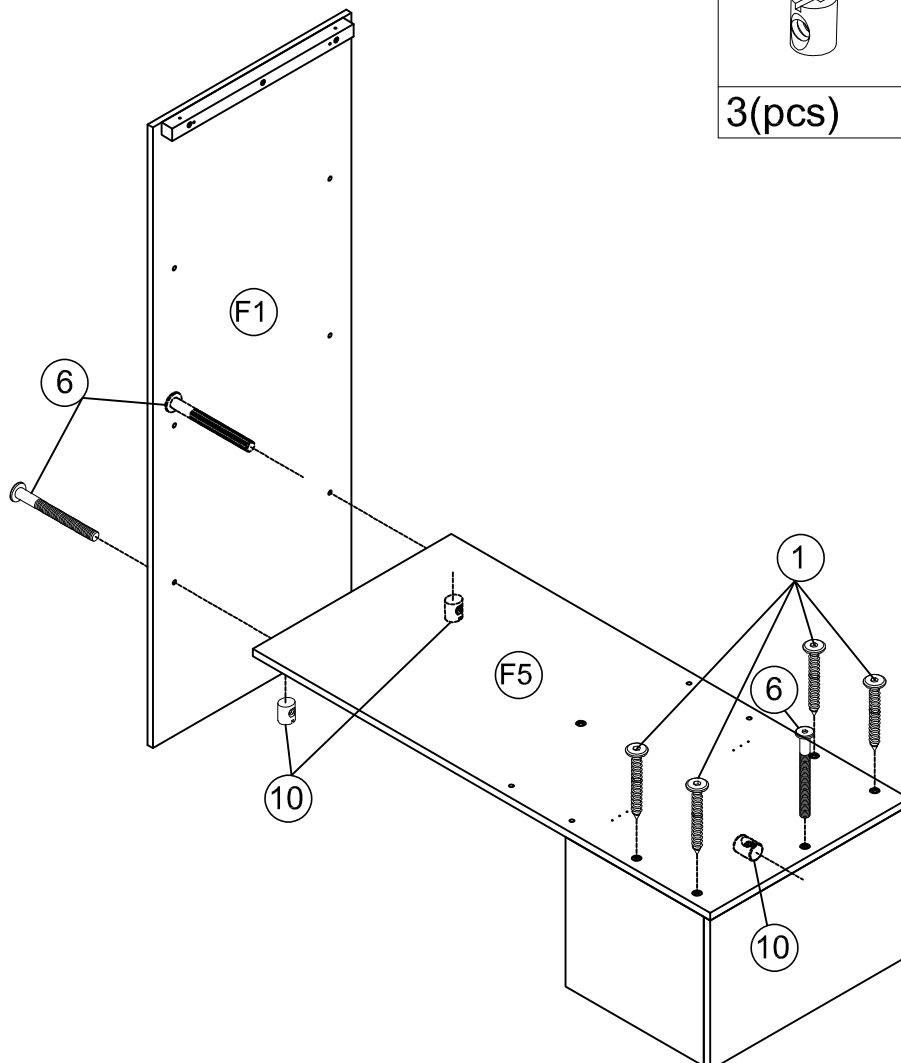

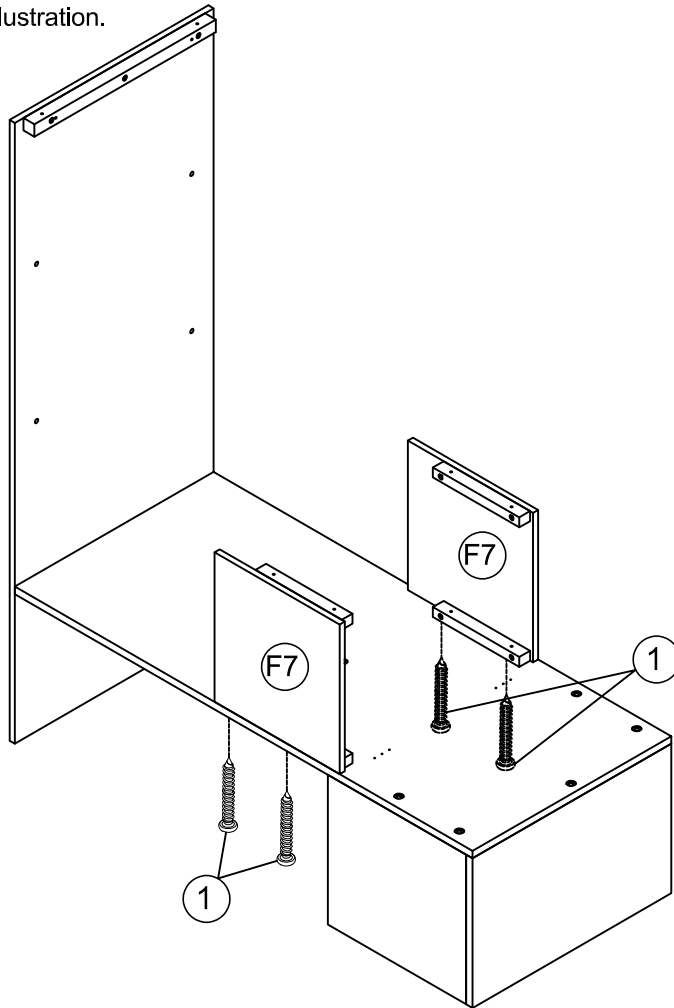

**STEP37:** Following below illustration.

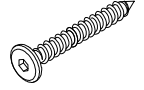

1

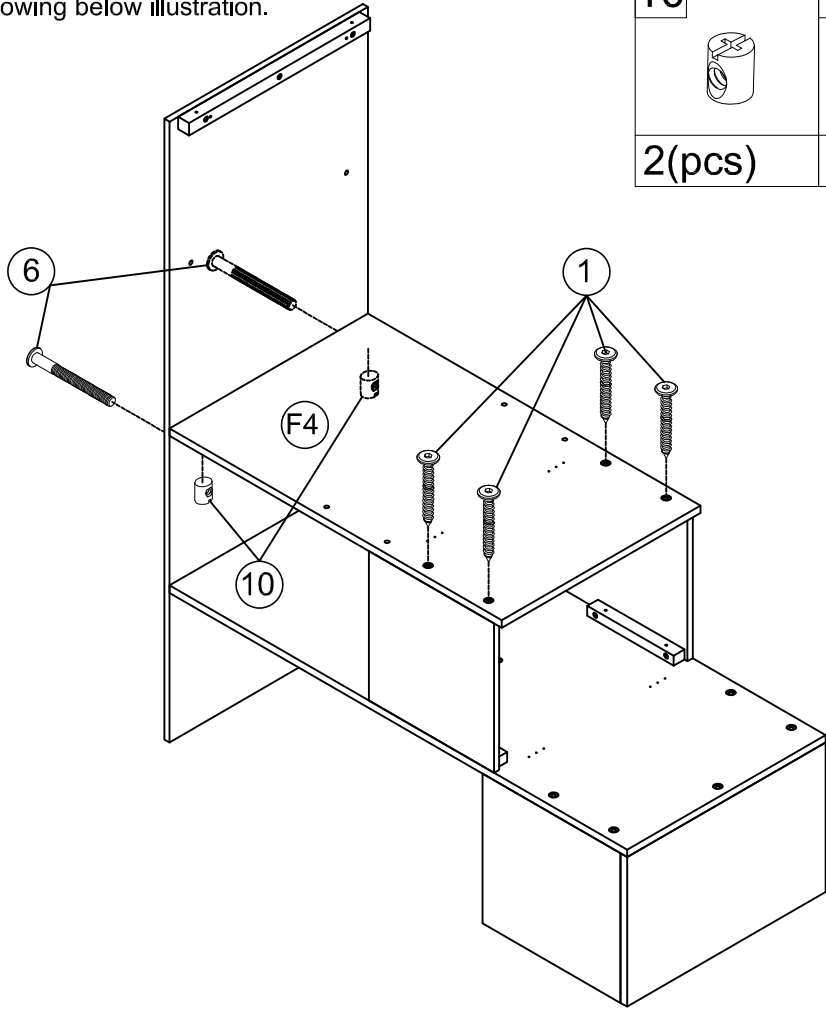
4(pcs)

**STEP38:** Following below illustration.

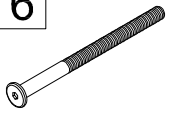
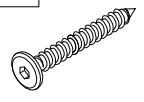

10	6	1
		
2(pcs)	2(pcs)	4(pcs)

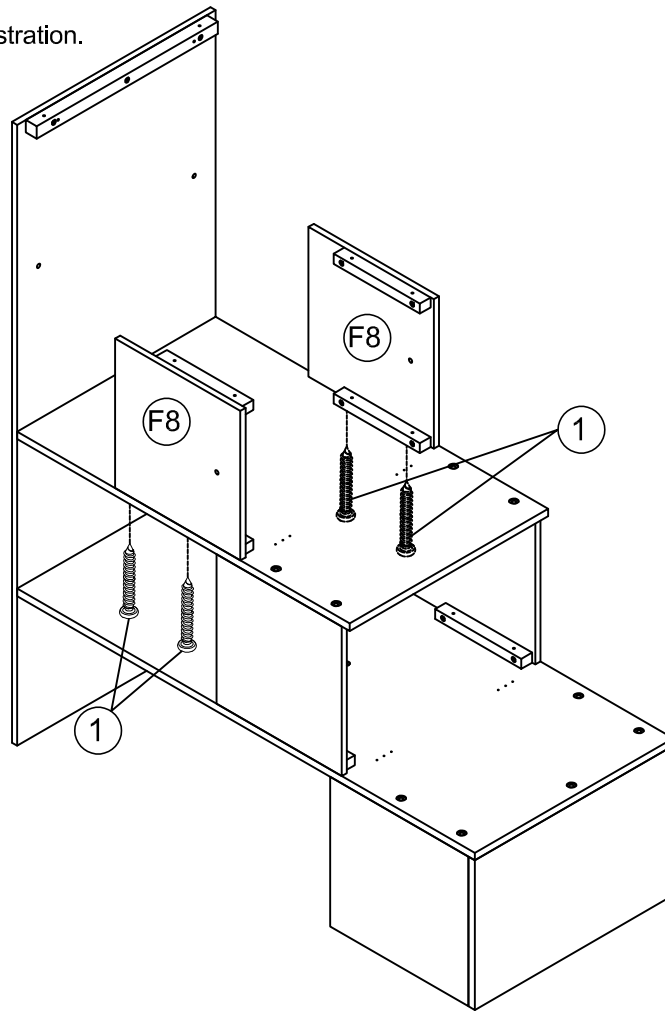
**STEP39:** Following below illustration.

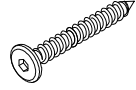

1

4(pcs)

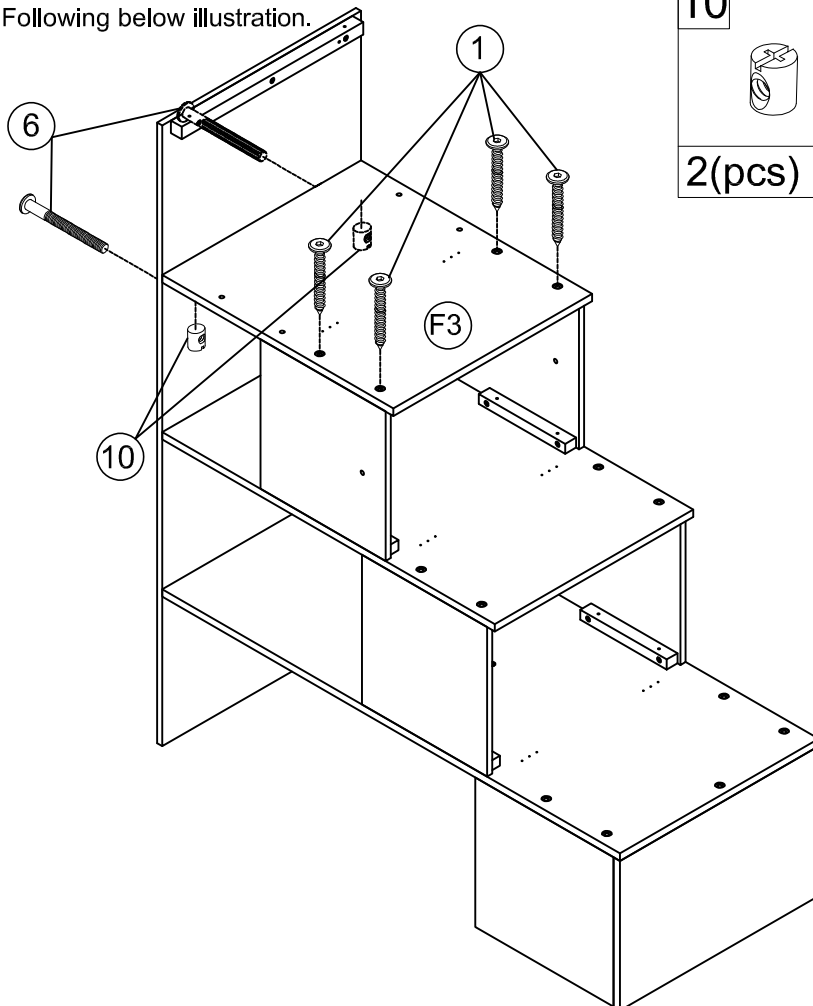
**STEP40:** Following below illustration.

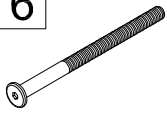
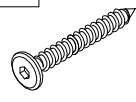

10	6	1
		
2(pcs)	2(pcs)	4(pcs)



**STEP41:** Following below illustration.

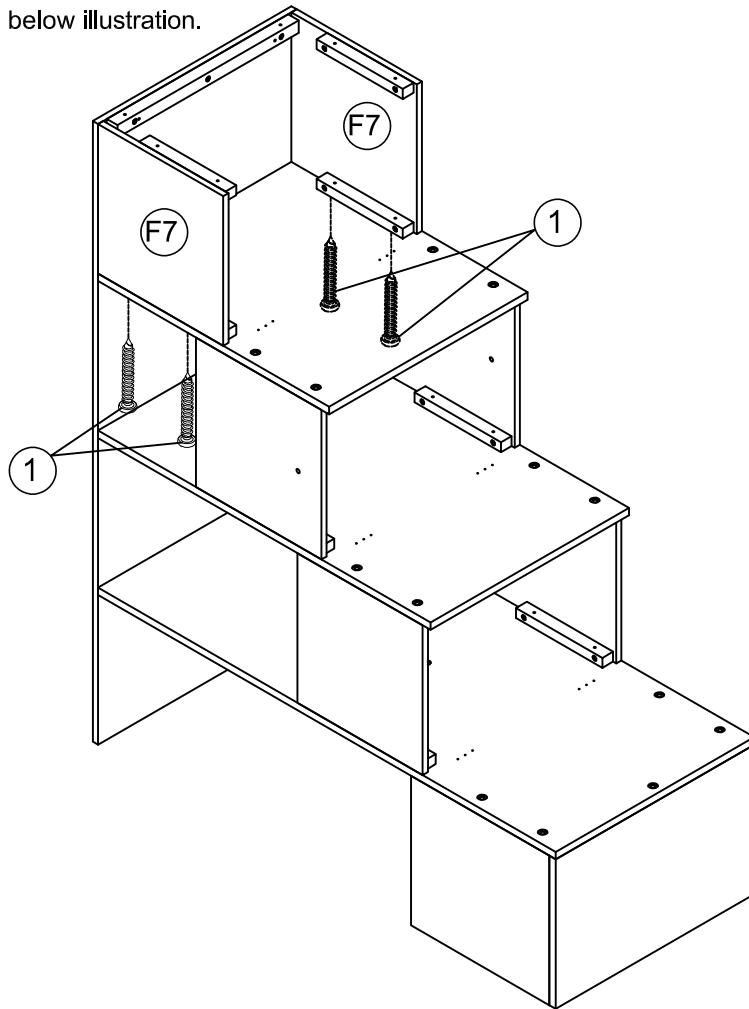

1

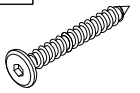

4(pcs)

**STEP42:** Following below illustration.

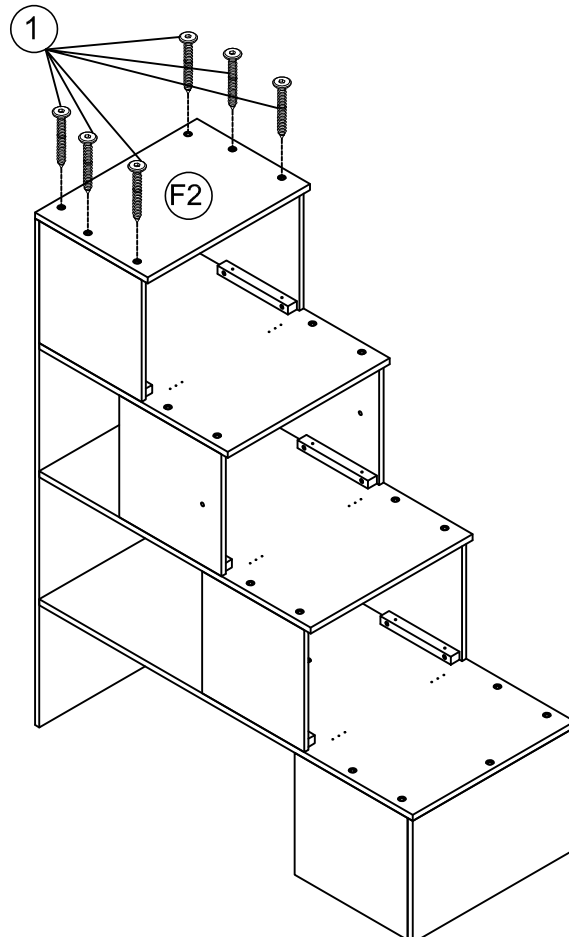

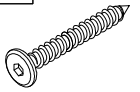

1



6(pcs)

# STEP43: Following below illustration.

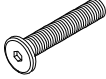
20	16	13	5
			
6(pcs)	12(pcs)	18(pcs)	1(pc)

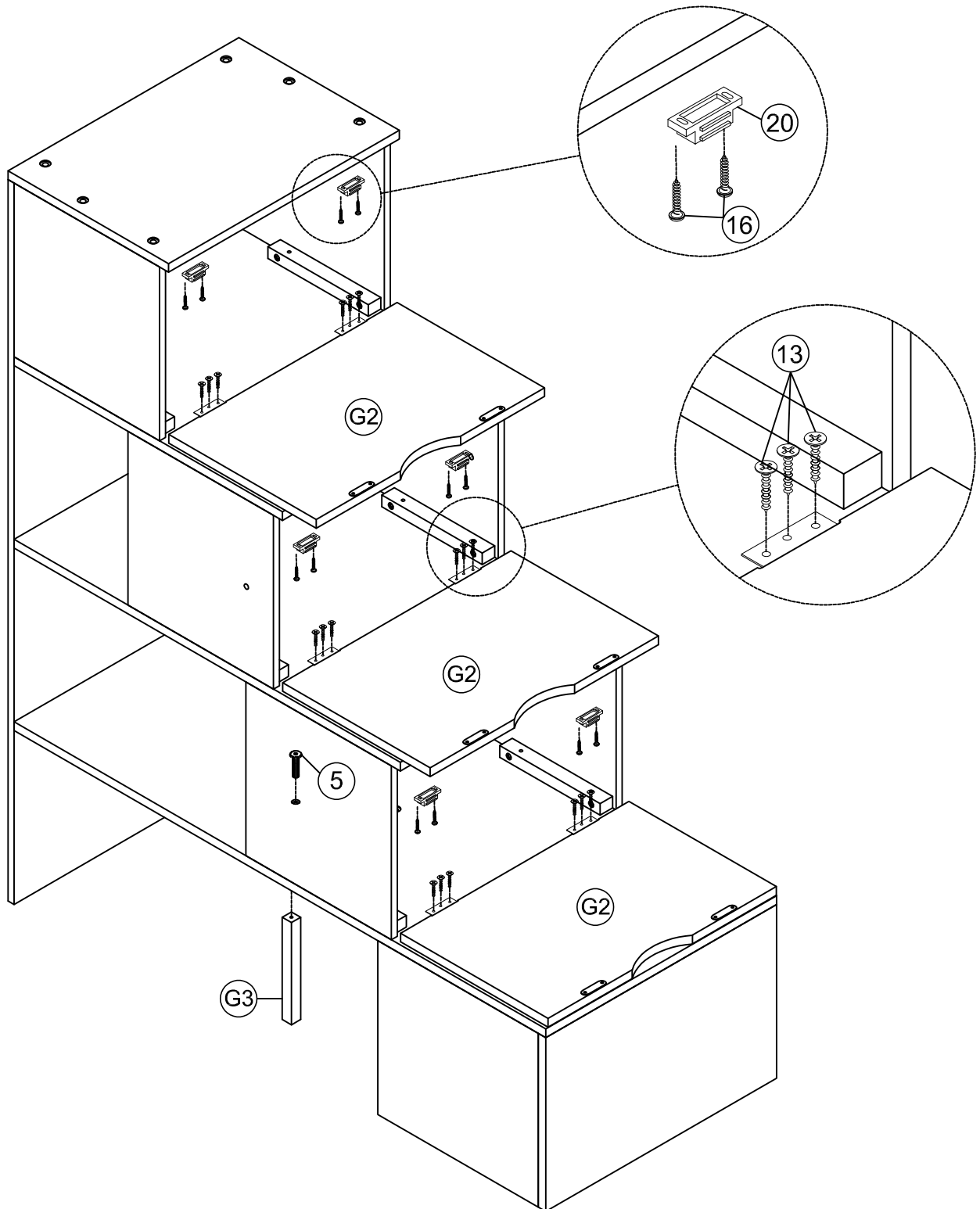

**STEP44:** Following below illustration.

2

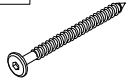

2(pcs)

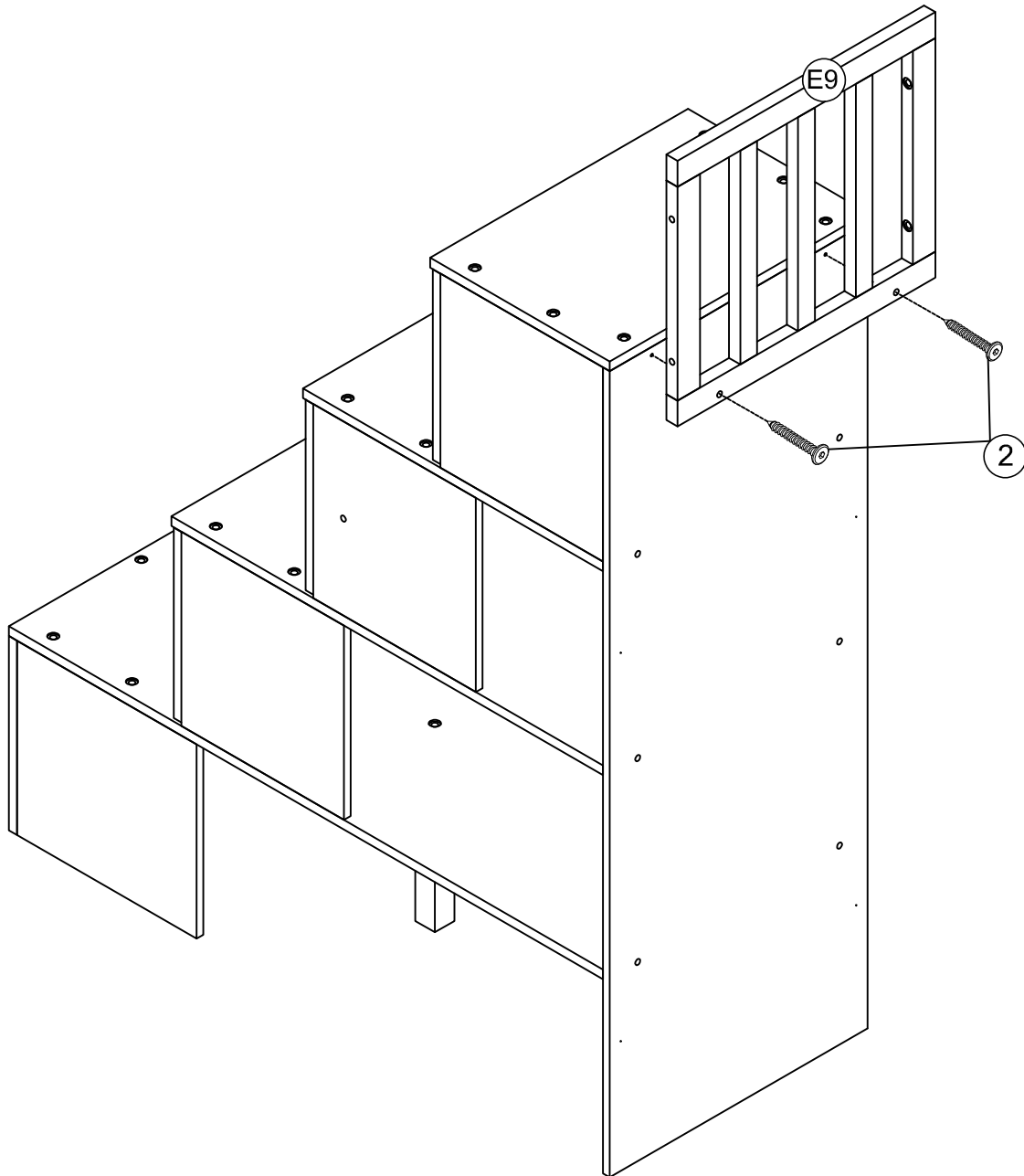

**STEP45:** Following below illustration.

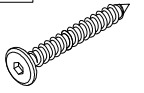

1

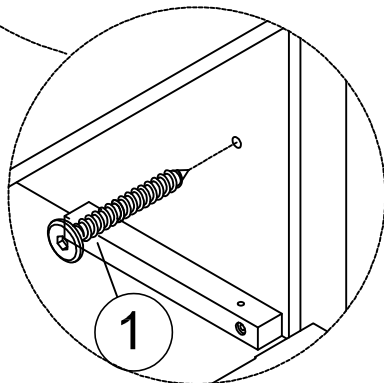
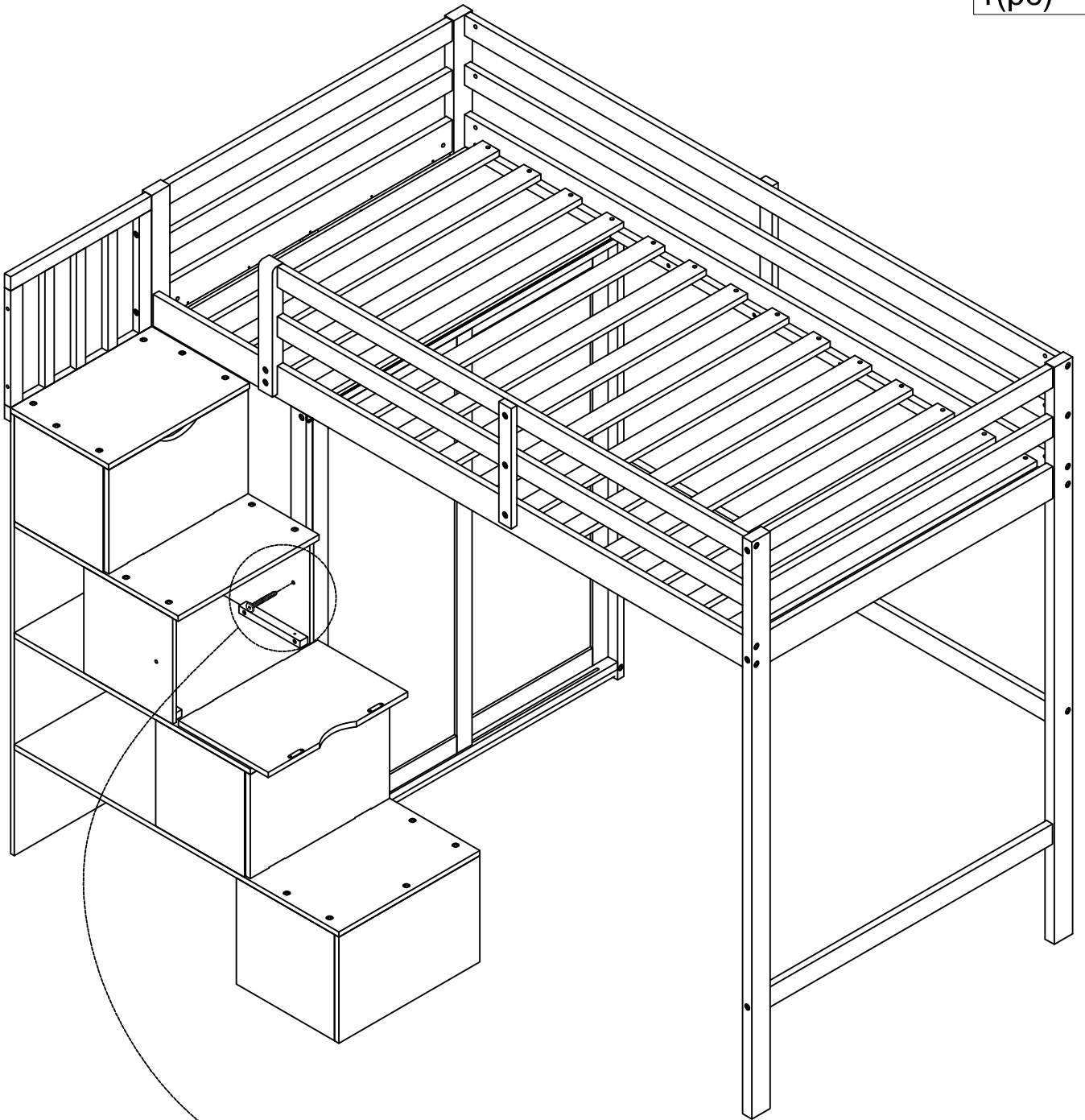

1(pc)

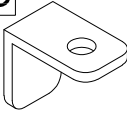

# STEP45: Following below illustration.

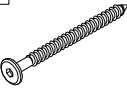
19	13	3
		
4(pcs)	8(pcs)	4(pcs)

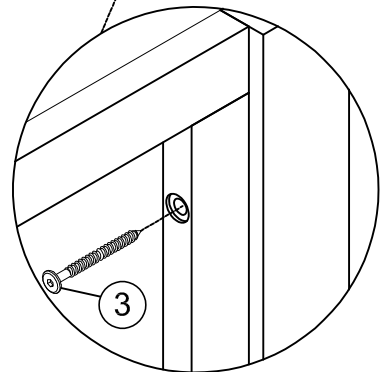
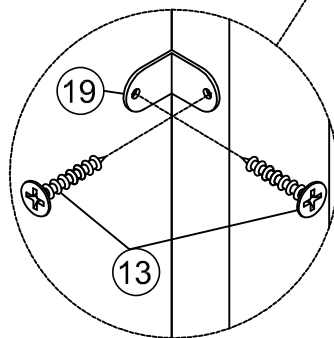
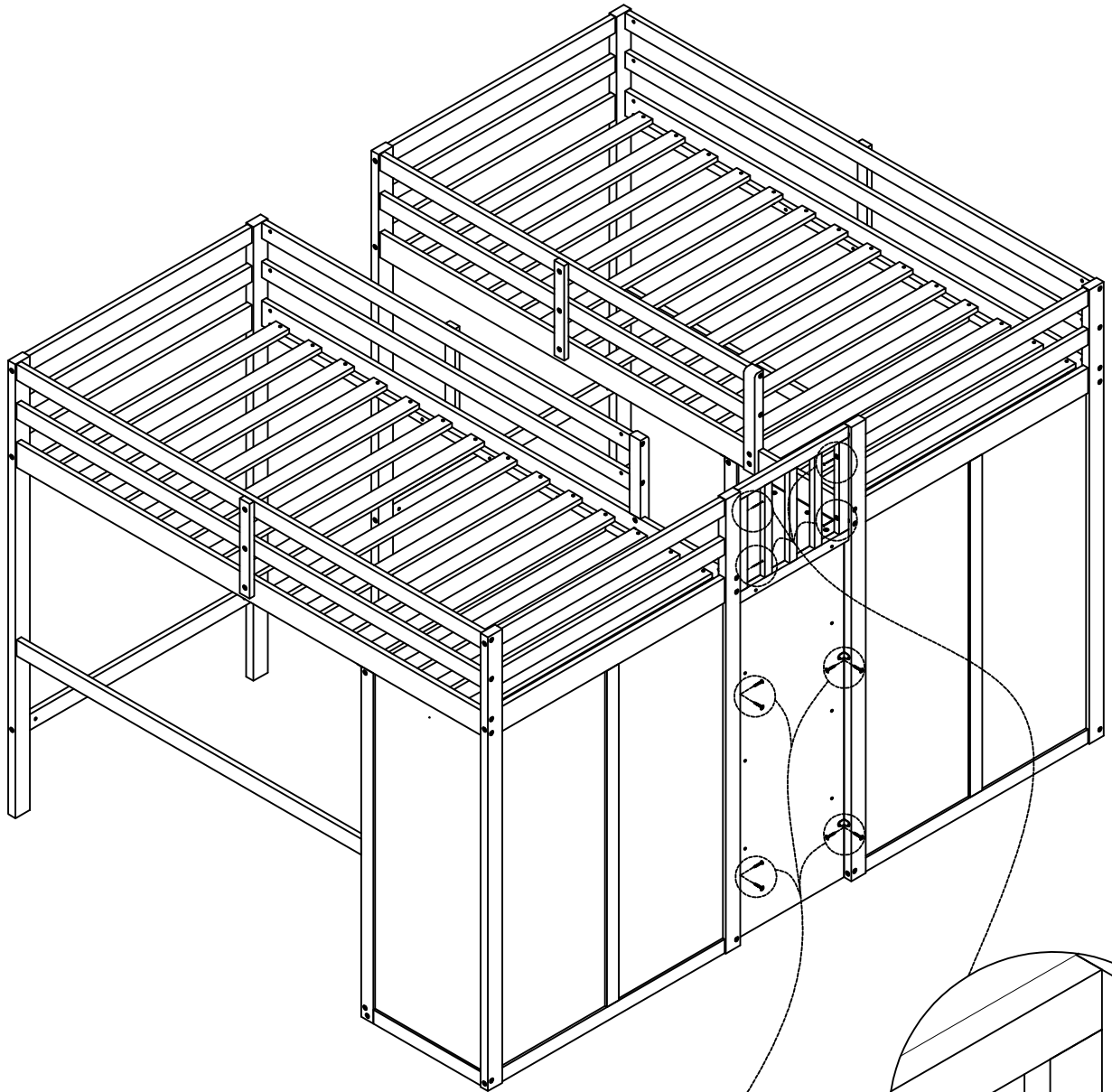

**STEP45:** Following below illustration.

1

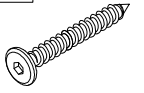

1(pc)

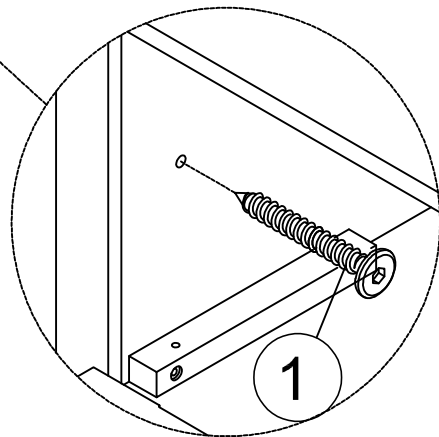
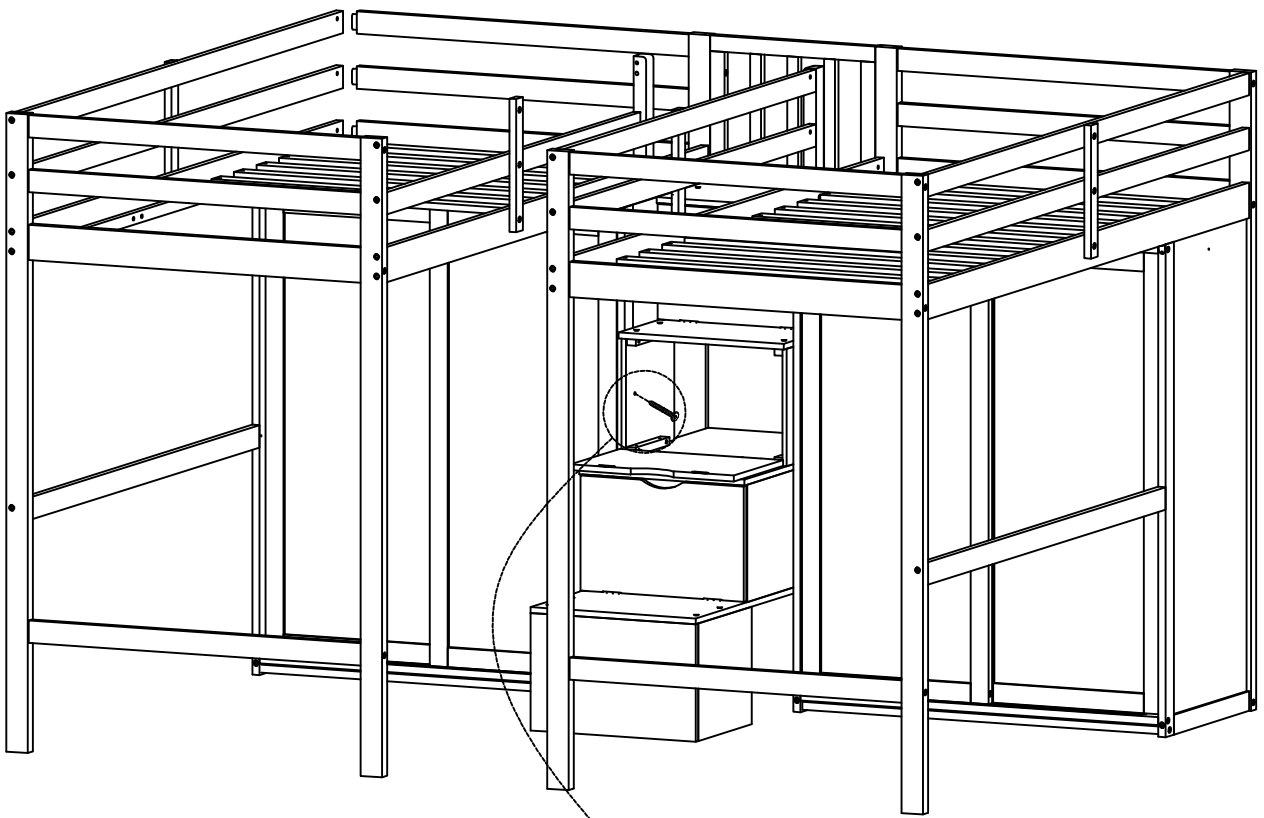

FINISH

