

# ASSEMBLY INSTRUCTIONS

## TWIN LOFT BED WITH DESK, 2 DRAWERS CHEST

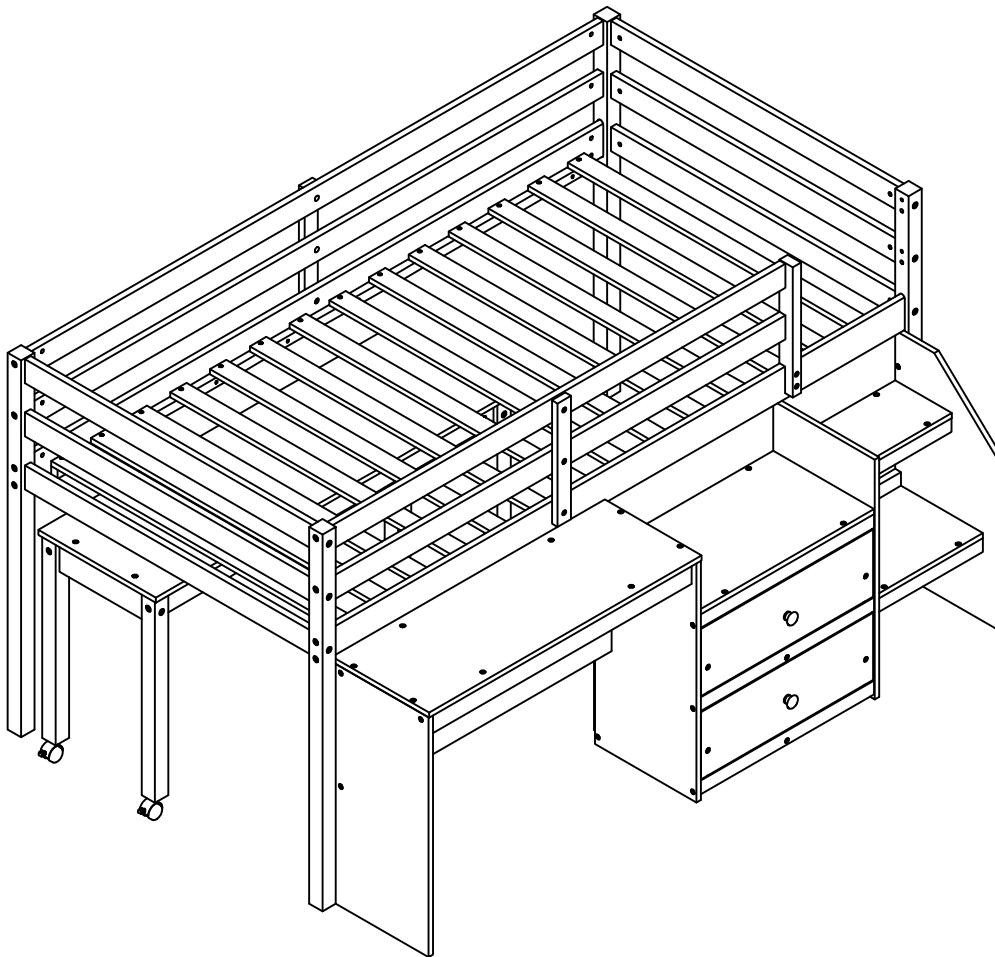





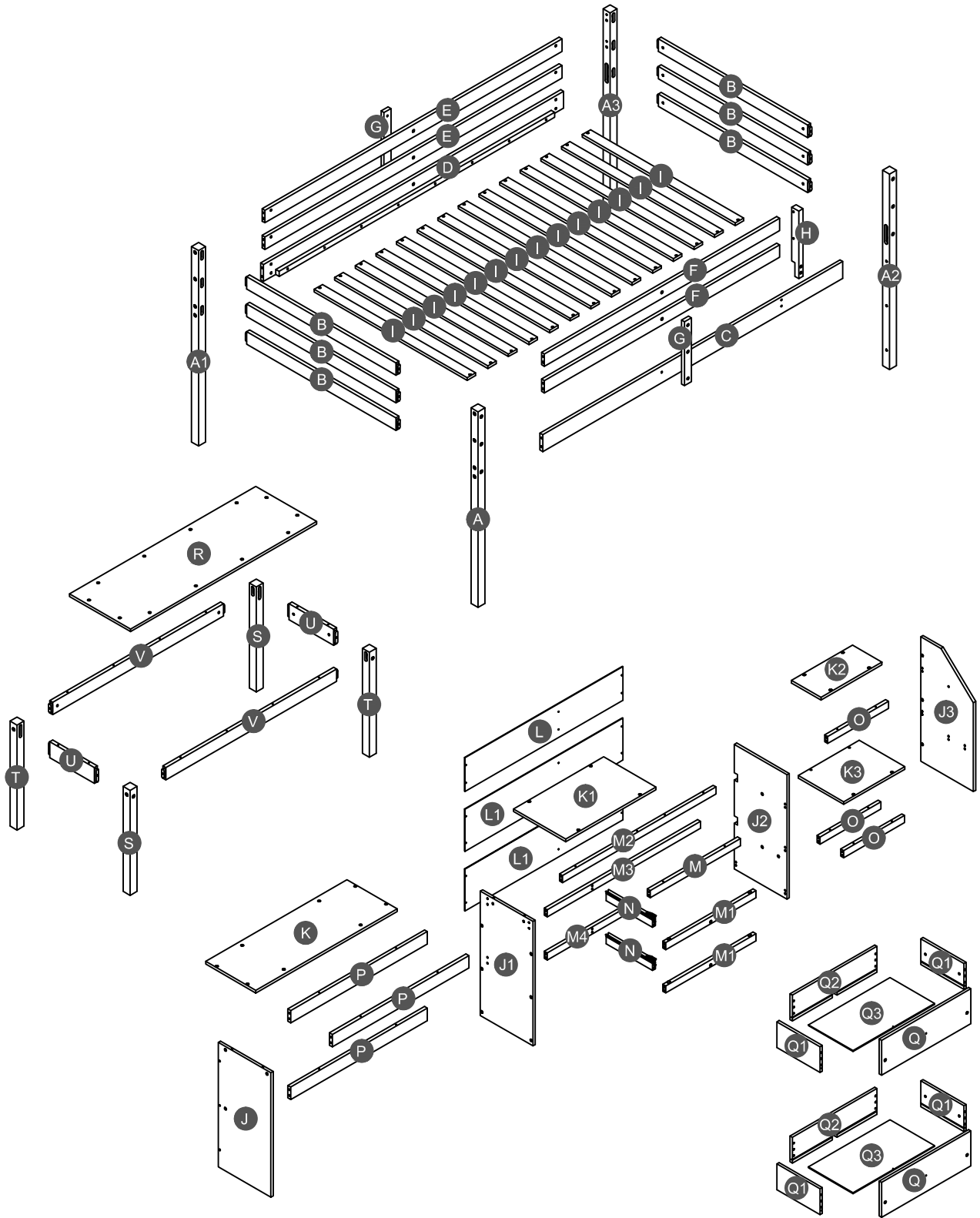





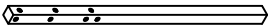
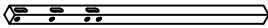
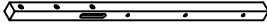
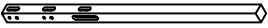
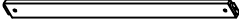

**WF303287/WF303288**

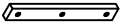
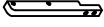
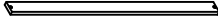
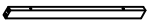
# Detail View



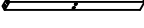

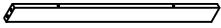
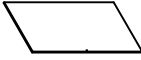
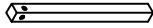
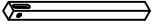

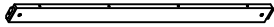





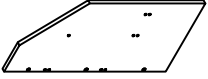

# Part List

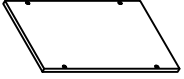
WF303287

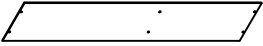
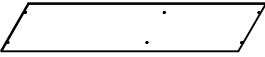

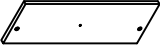

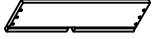





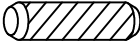
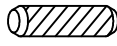

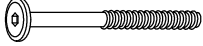
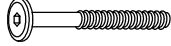

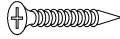

<p><b>A</b></p>  <p>Leg (Left Front) - 1pc</p>	<p><b>A1</b></p>  <p>Leg (Left Back) - 1pc</p>	<p><b>A2</b></p>  <p>Leg (Right Front) - 1pc</p>
<p><b>A3</b></p>  <p>Leg (Right Back) - 1pc</p>	<p><b>B</b></p>  <p>Horizontal bar FB/HB - 6pcs</p>	<p><b>C</b></p>  <p>Side rail (Front) - 1pc</p>
<p><b>D</b></p>  <p>Side rail (Back) - 1pc</p>	<p><b>E</b></p>  <p>Long guard rail (back) - 2pcs</p>	<p><b>F</b></p>  <p>Short guard rail (front) - 2pcs</p>
<p><b>G</b></p>  <p>Vertical guard rail - 2pcs</p>	<p><b>H</b></p>  <p>Support guard rail (Right) - 1pc</p>	<p><b>I</b></p>  <p>Slat - 14pcs</p>
<p><b>M</b></p>  <p>Upper horizontal bar (front) - 1pc</p>	<p><b>M1</b></p>  <p>Lower horizontal bar (front) - 2pcs</p>	<p><b>M2</b></p>  <p>Upper horizontal bar (back) - 1pc</p>
<p><b>M3</b></p>  <p>Divider horizontal bar (back) - 1pc</p>	<p><b>M4</b></p>  <p>Lower horizontal bar (back) - 1pc</p>	<p><b>O</b></p>  <p>Horizontal bar (right) - 3pcs</p>
<p><b>P</b></p>  <p>Horizontal bar (left) - 3pcs</p>	<p><b>Q3</b></p>  <p>Drawer bottom - 2pcs</p>	<p><b>S</b></p>  <p>Leg (Left Front/Right Back) - 2pcs</p>
<p><b>T</b></p>  <p>Leg (Left Back/Right Front) - 2pcs</p>	<p><b>U</b></p>  <p>Apron (left-right) - 2pcs</p>	<p><b>V</b></p>  <p>Apron (front-back) - 2pcs</p>

# Part List

## WF303288 - Hardware inside

<b>J</b>  Side panel (left) - 1pc	<b>J1</b>  Divider panel (left) - 1pc	<b>J2</b>  Divider panel (right) - 1pc
<b>J3</b>  Side panel (right) - 1pc	<b>K</b>  Top panel (left) - 1pc	<b>K1</b>  Top panel (right) - 1pc
<b>K2</b>  Shelf panel - 1pc	<b>K3</b>  Shelf panel - 1pc	<b>L</b>  Upper back panel - 1pc
<b>L1</b>  Lower back panel - 2pcs	<b>N</b>  Support drawer - 2pcs	<b>Q</b>  Drawer front - 2pcs
<b>Q1</b>  Drawer (left/right) - 4pcs	<b>Q2</b>  Drawer back - 2pcs	<b>R</b>  Top table - 1pc

## Hardware List WF303288

<b>1</b>	 Ø10*40mm Wood dowel (8pcs)	<b>2</b>	 Ø8*30mm Wood dowel (40pcs)	<b>3</b>	 (Ø15)1/4"*100mm Hex-Head bolts (14pcs)
<b>4</b>	 (Ø15)1/4"*80mm Hex-Head bolts (22pcs)	<b>5</b>	 (Ø12)1/4"*60mm Hex-Head bolts (40pcs)	<b>6</b>	 (Ø12)1/4"*35mm Hex-Head bolts (8pcs)
<b>7</b>	 (Ø12)1/4"*30mm Hex-Head bolts (6pcs)	<b>8</b>	 1/4"*15 (9.5mm) Horizontal-Hole bolts(76pcs)	<b>9</b>	 (Ø12)1/4"*40mm Hex-Head bolts (28pcs)
<b>10</b>	 (1/4")4.5*58mm Allen key (1pc)	<b>11</b>	 Ø4*30mm Wood screws (28pcs)	<b>12</b>	 Ø3.5*15mm Wood screws (6pcs)
<b>13</b>	 Ø3.5*15mm Wood screws (18pcs)	<b>14</b>	 64*52*95mm Castor (2pcs)	<b>15</b>	 64*52*95mm Castor (2pcs)
<b>16</b>	 295*30mm Upper slider drawer (2pcs)	<b>17</b>	 Ø38*31mm Pine Knob (2pcs)	<b>18</b>	 3/16"*25mm Ph zinc(Knob) (2pcs)

### ASSEMBLY TOOLS REQUIRED ( NOT INCLUDED )

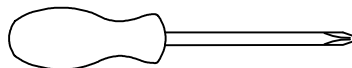

PLEASE BE CAREFUL DO NOT DAMAGE THE HOLE POSITION WHEN YOU USE POWER TOOLS !

**STEP 1:**

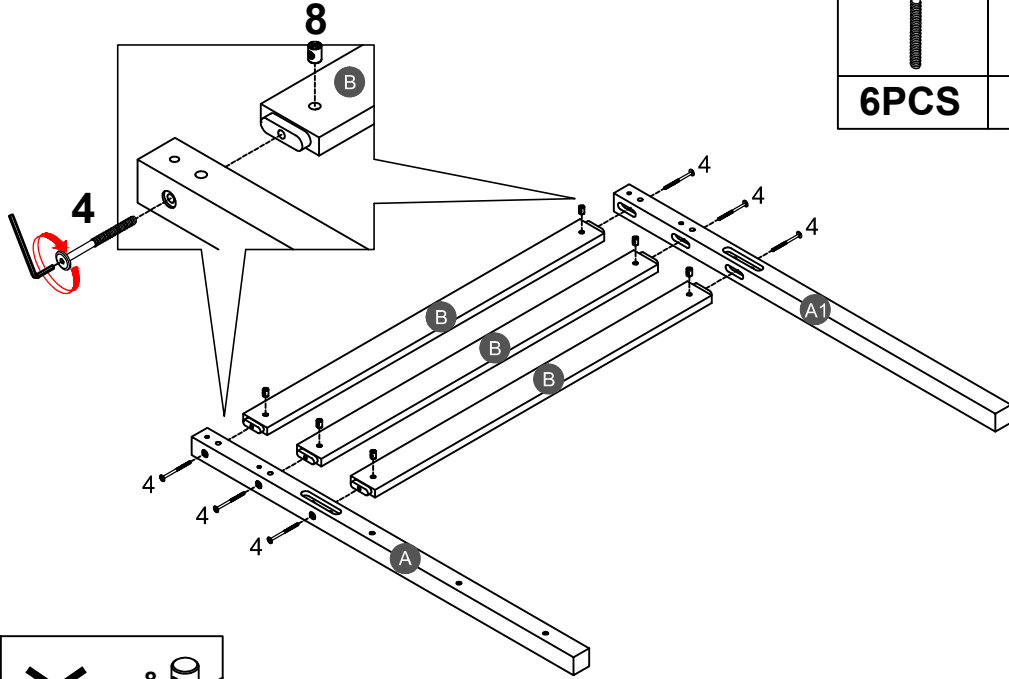

4		8	
6PCS		6PCS	

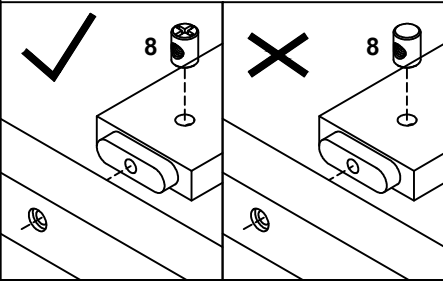

Note: Part 8 will face up with the "x" mark on it, otherwise it cannot be tightened

**STEP 2:**

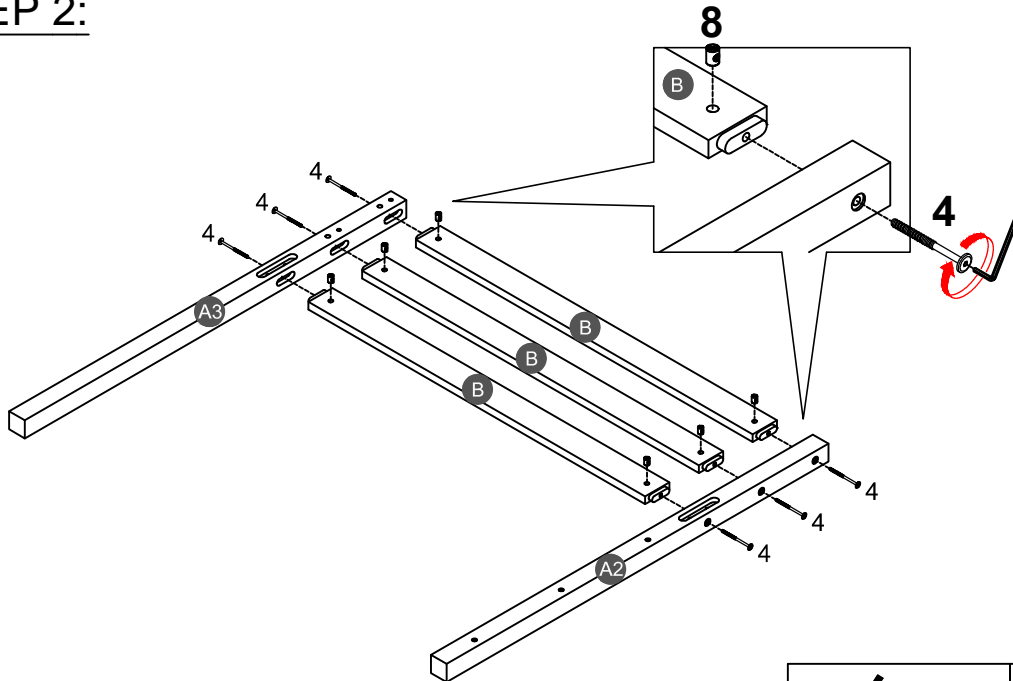



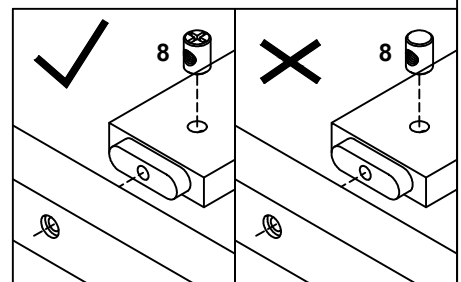

4	
6PCS	
8	
6PCS	

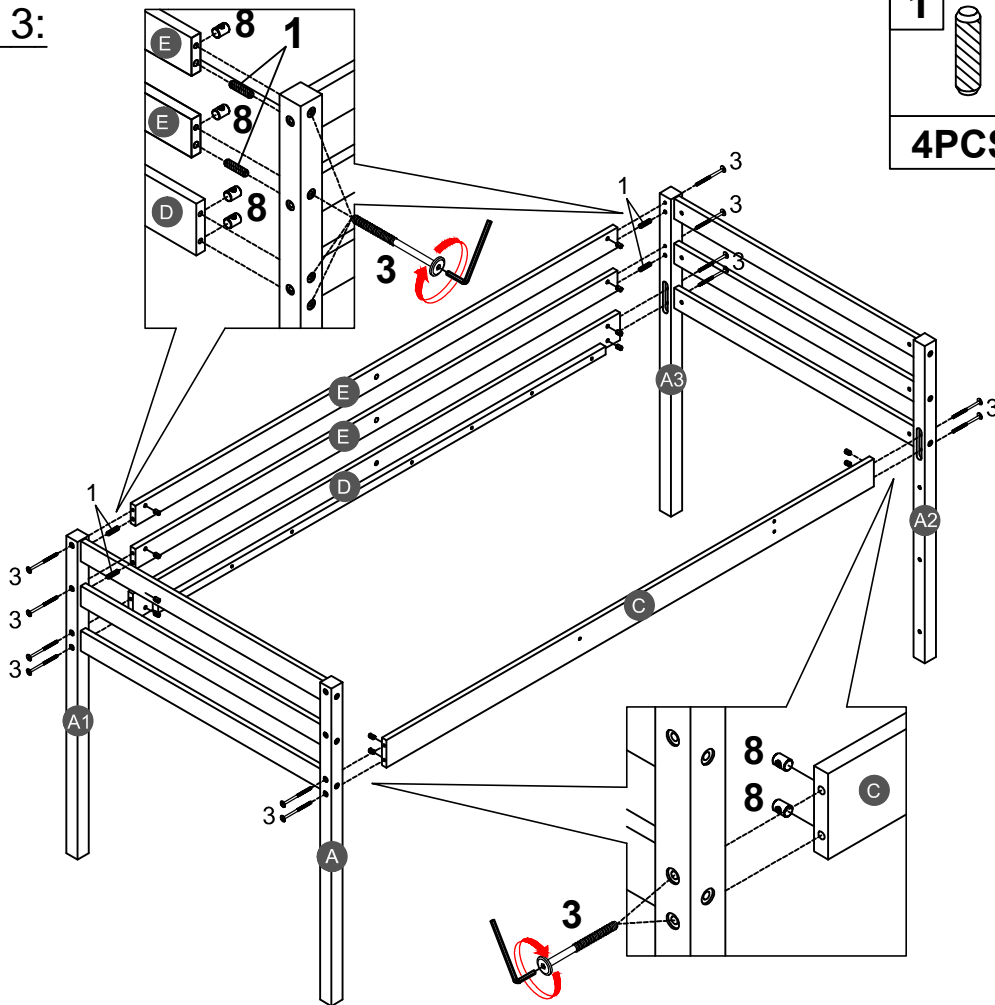

Note: Part 8 will face up with the "x" mark on it, otherwise it cannot be tightened

**STEP 3:**



<b>1</b>		<b>3</b>	
<b>4PCS</b>		<b>12PCS</b>	
		<b>8</b>	
		<b>12PCS</b>	

**STEP 4:**

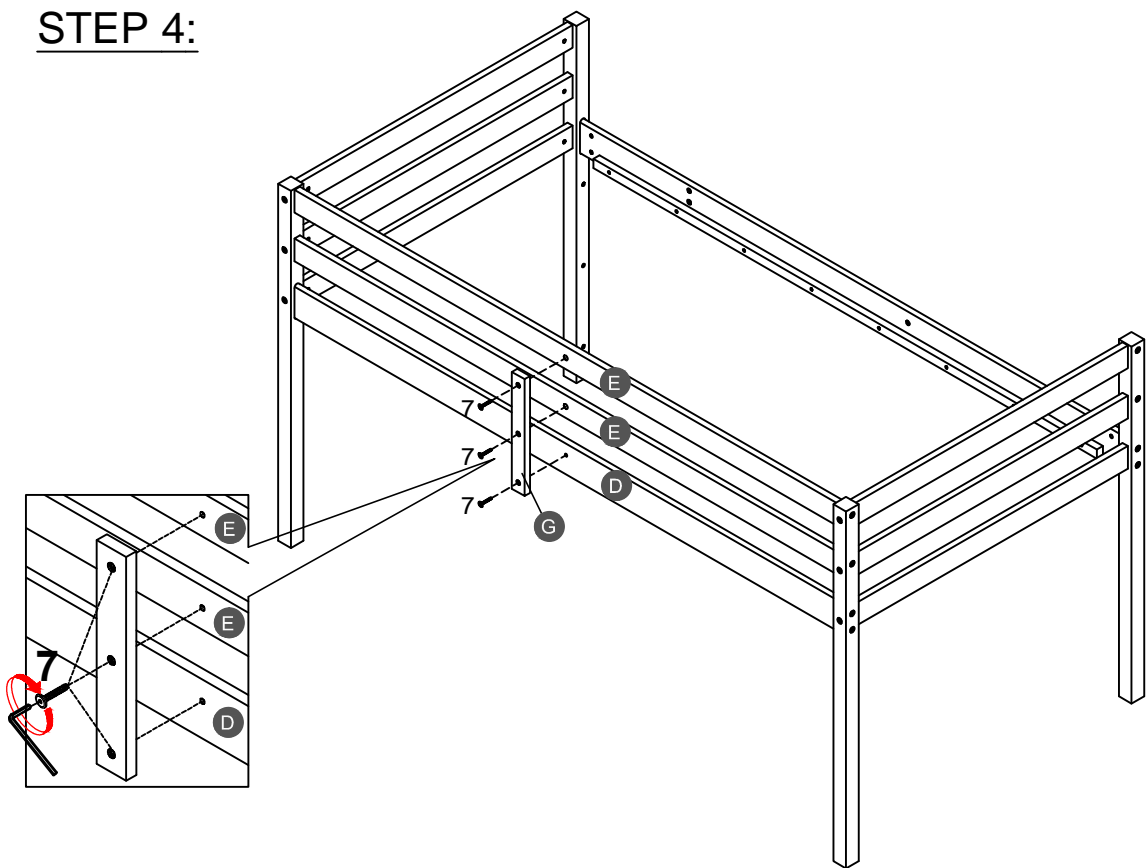

<b>7</b>	
<b>3PCS</b>	

**STEP 5:**

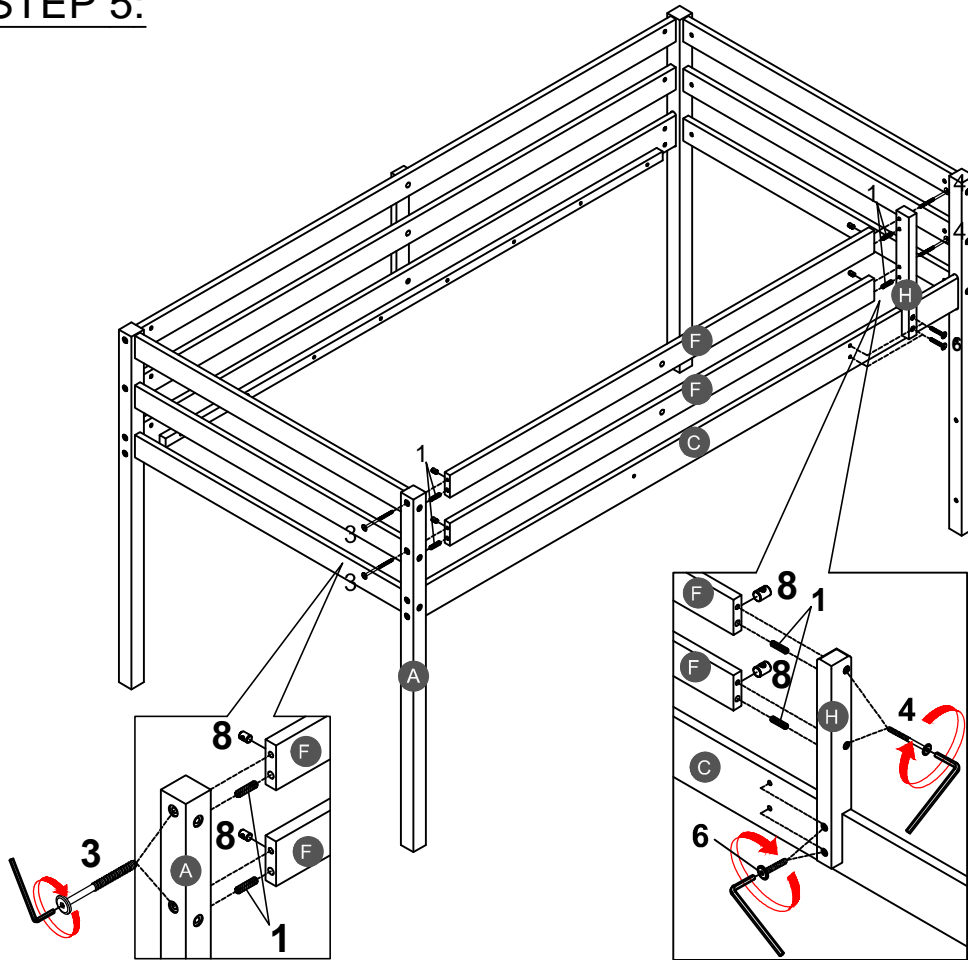

1		3	
4PCS		2PCS	
4		2PCS	
6		2PCS	
8		4PCS	

**STEP 6:**

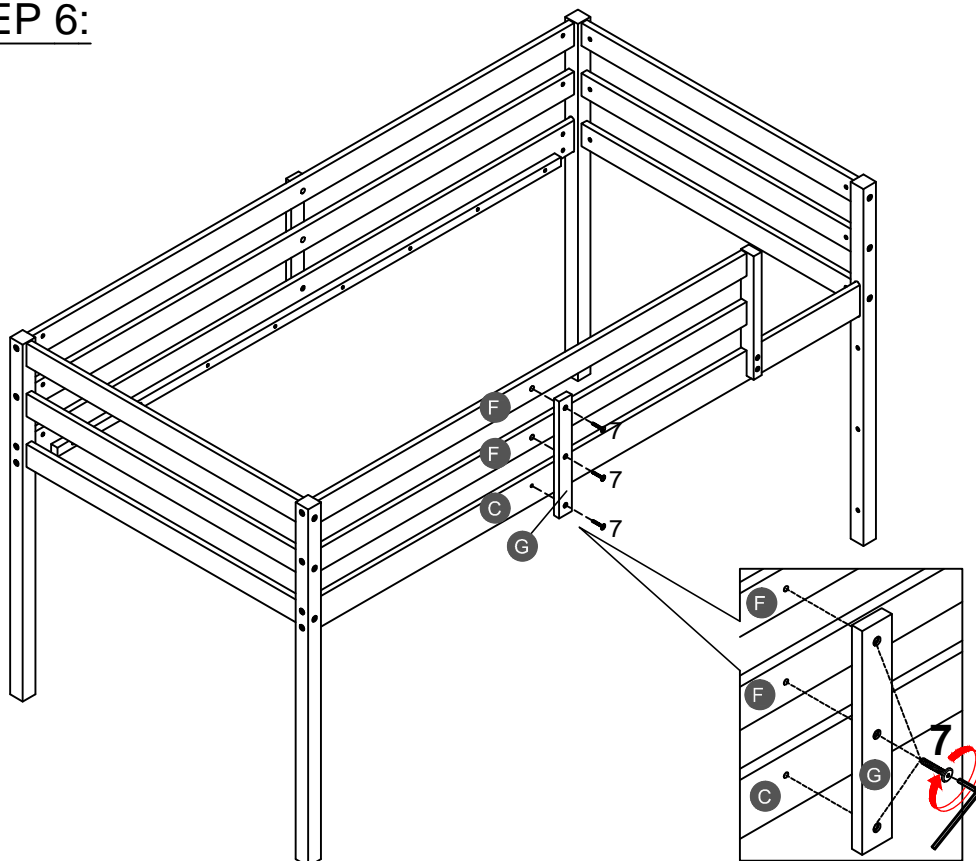

7	
3PCS	



### STEP 7:

11



28PCS

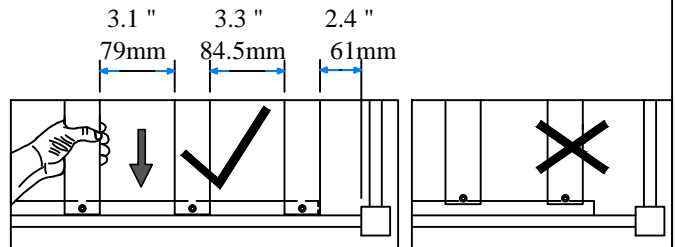
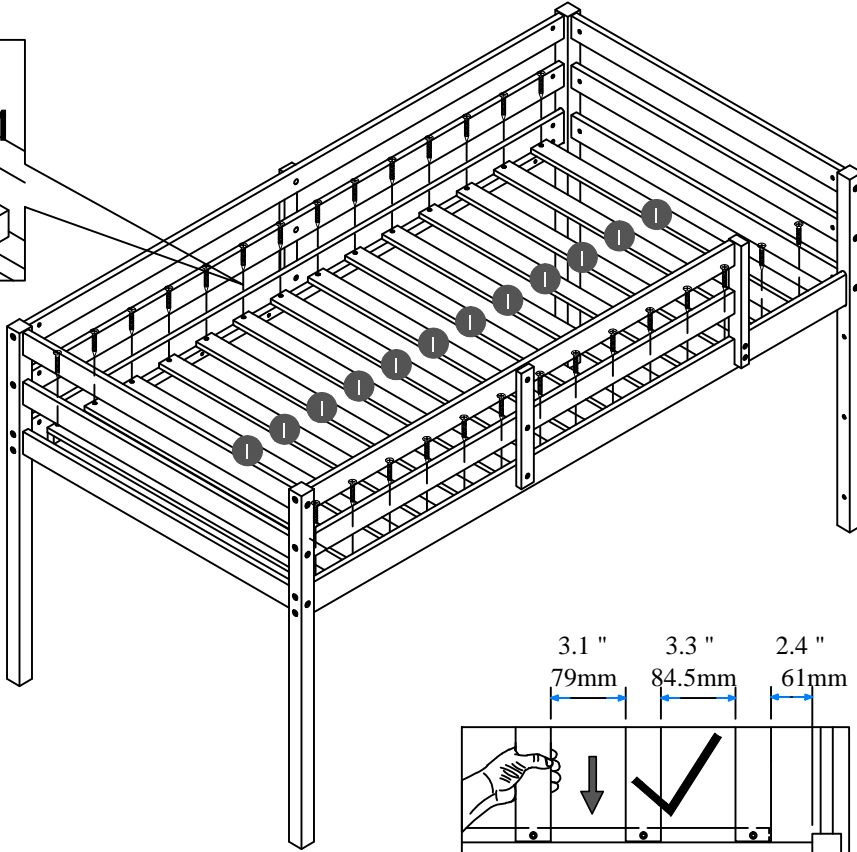
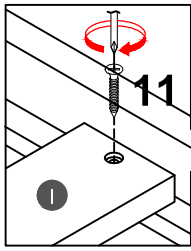

Note: Do not lock the screws of the bed slats to the outermost edge of the bed slats, you need to leave a certain space at the edges, otherwise it will cause the board to break. Do not lock the bed slats on the edge of the wood, please hold firmly before screwing, hold it in place with one hand, then lock the screw.

### STEP 8:

5



2PCS



8

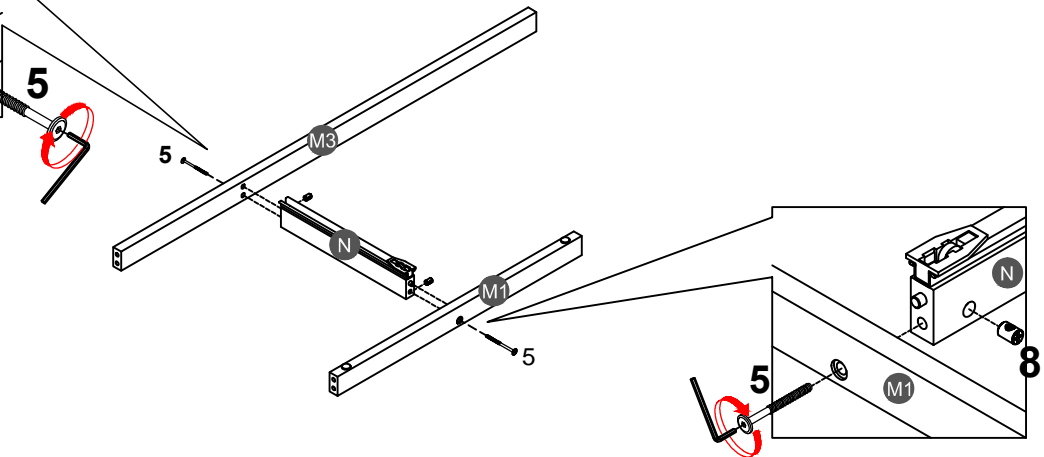
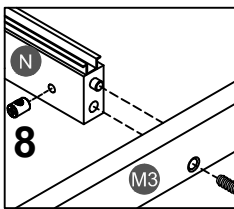

2PCS



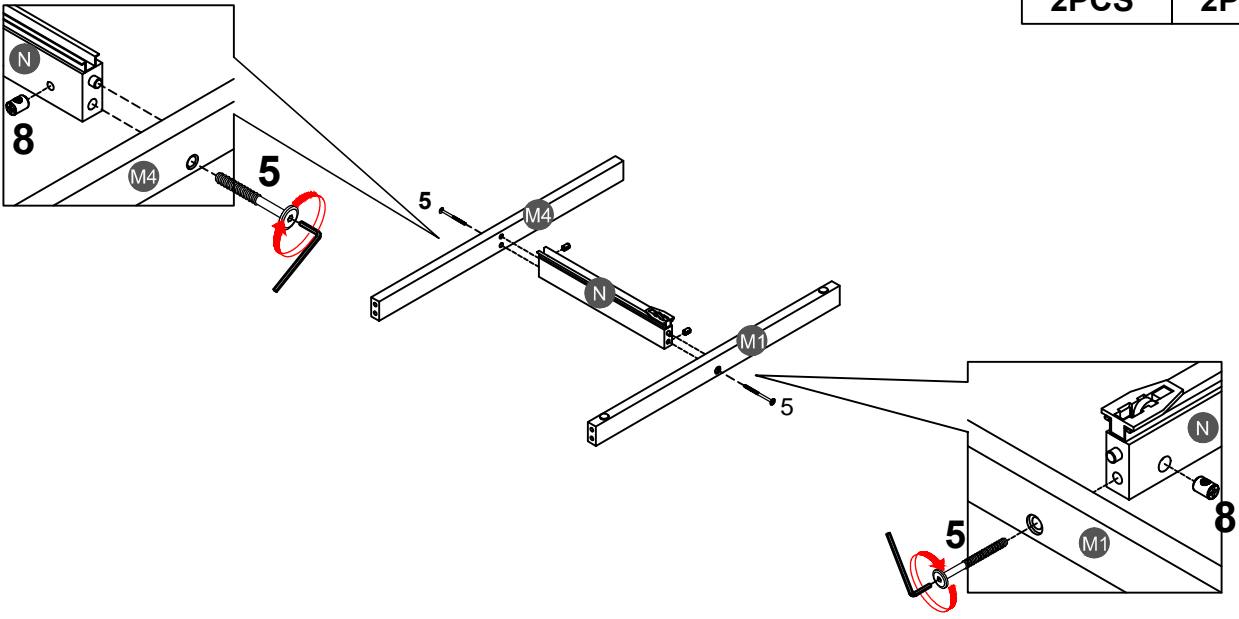

**STEP 9:**

<b>5</b>		<b>8</b>	
<b>2PCS</b>		<b>2PCS</b>	



**STEP 10:**

<b>2</b>	
<b>10PCS</b>	
<b>5</b>	
<b>10PCS</b>	
<b>8</b>	
<b>10PCS</b>	

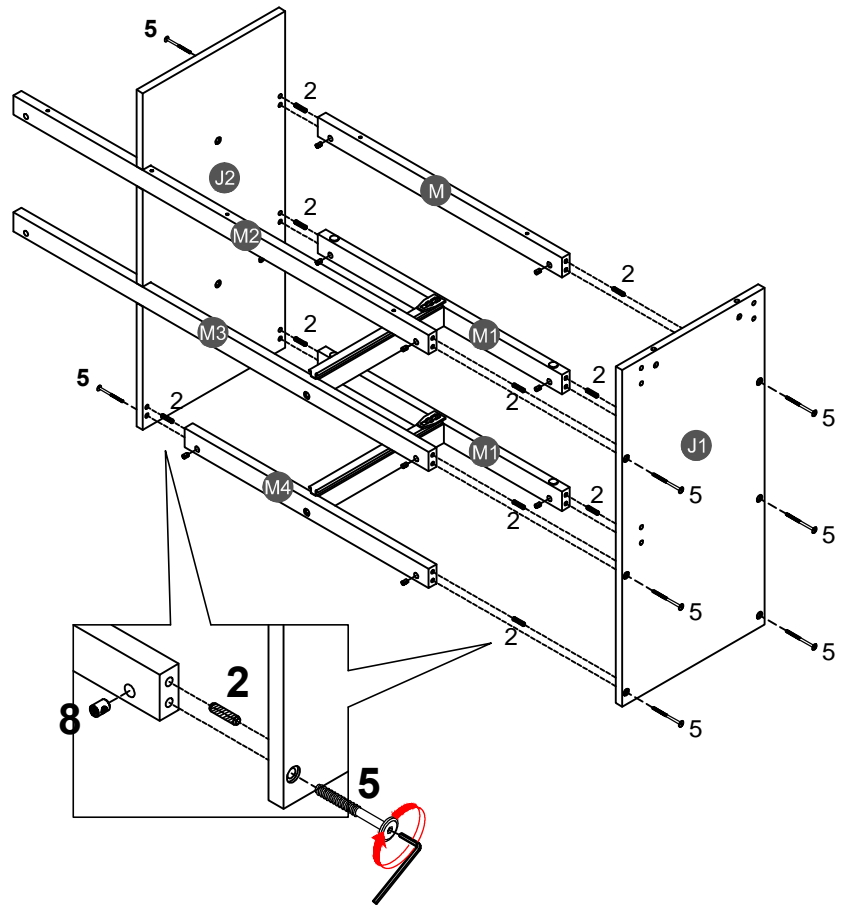

### STEP 11:

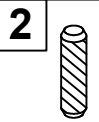
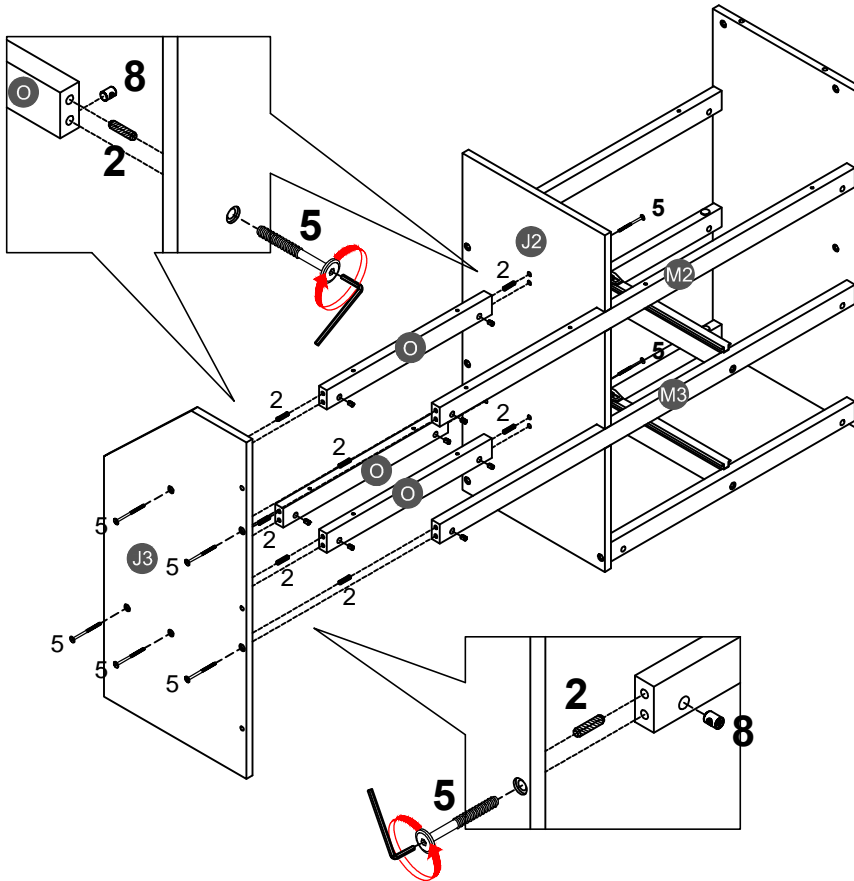

8PCS

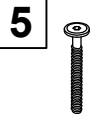

8PCS

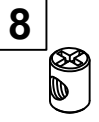

8PCS

### STEP 12:

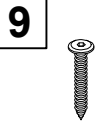
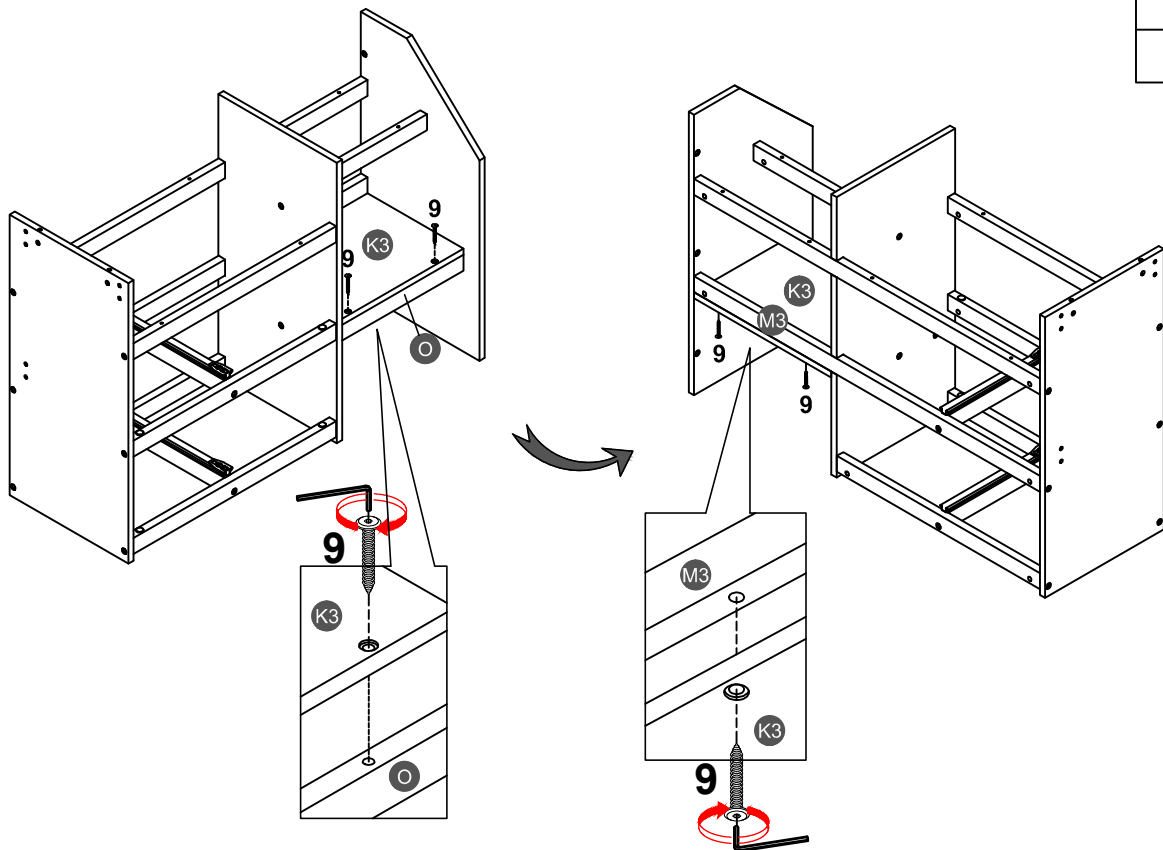

4PCS

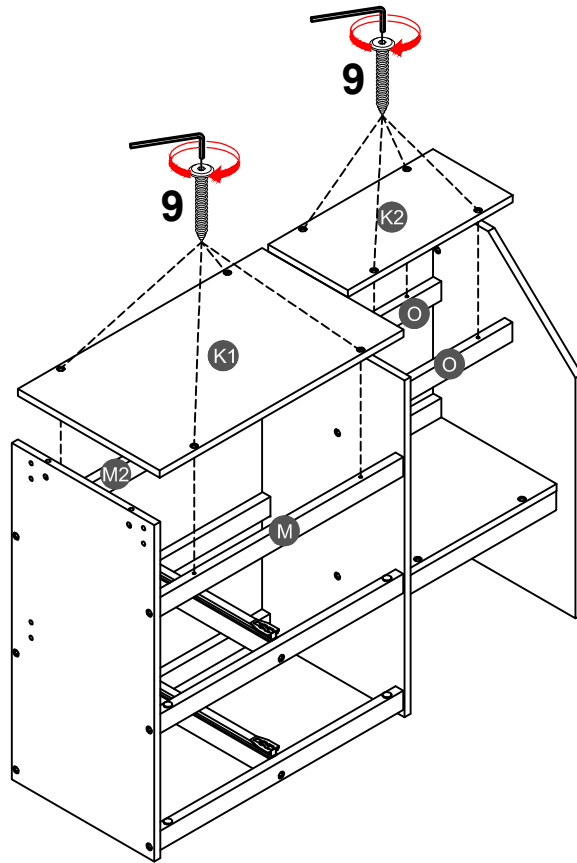

**STEP 13:**

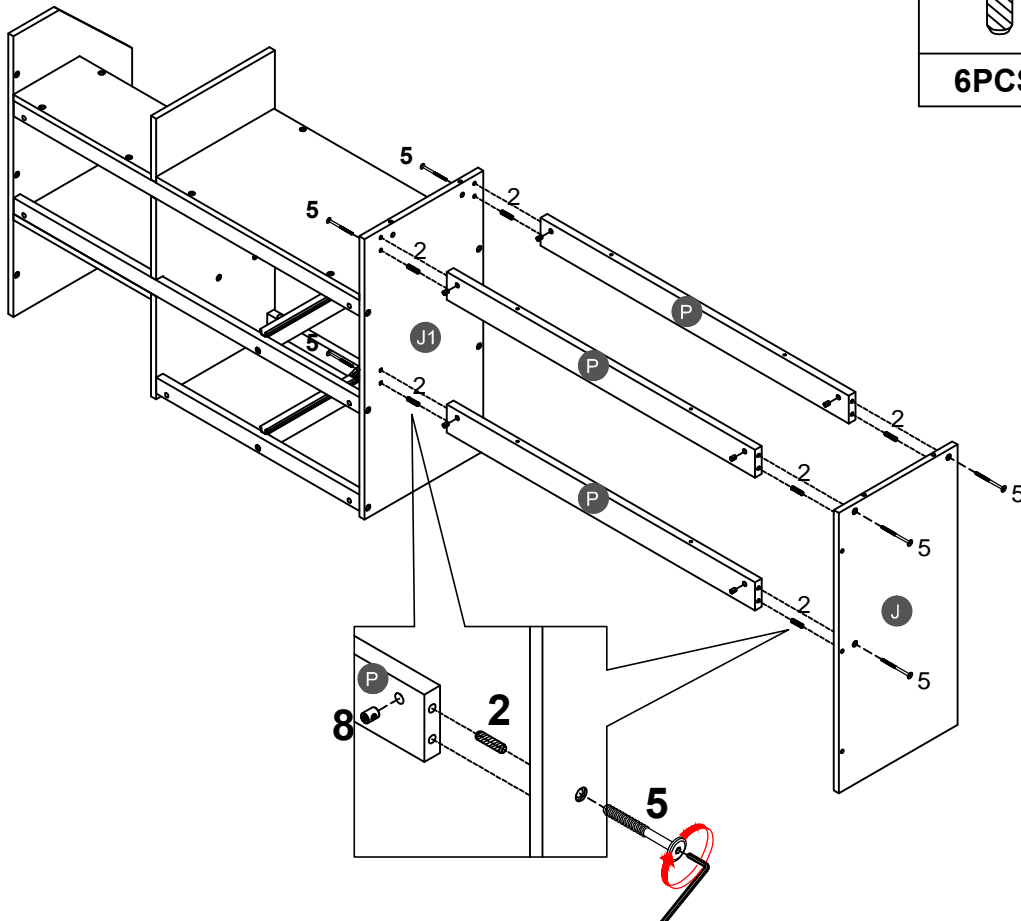

<b>9</b>	
<b>8PCS</b>	

**STEP 14:**



<b>2</b>		<b>5</b>	
<b>6PCS</b>		<b>6PCS</b>	
		<b>8</b>	
<b>6PCS</b>			

**STEP 15:**

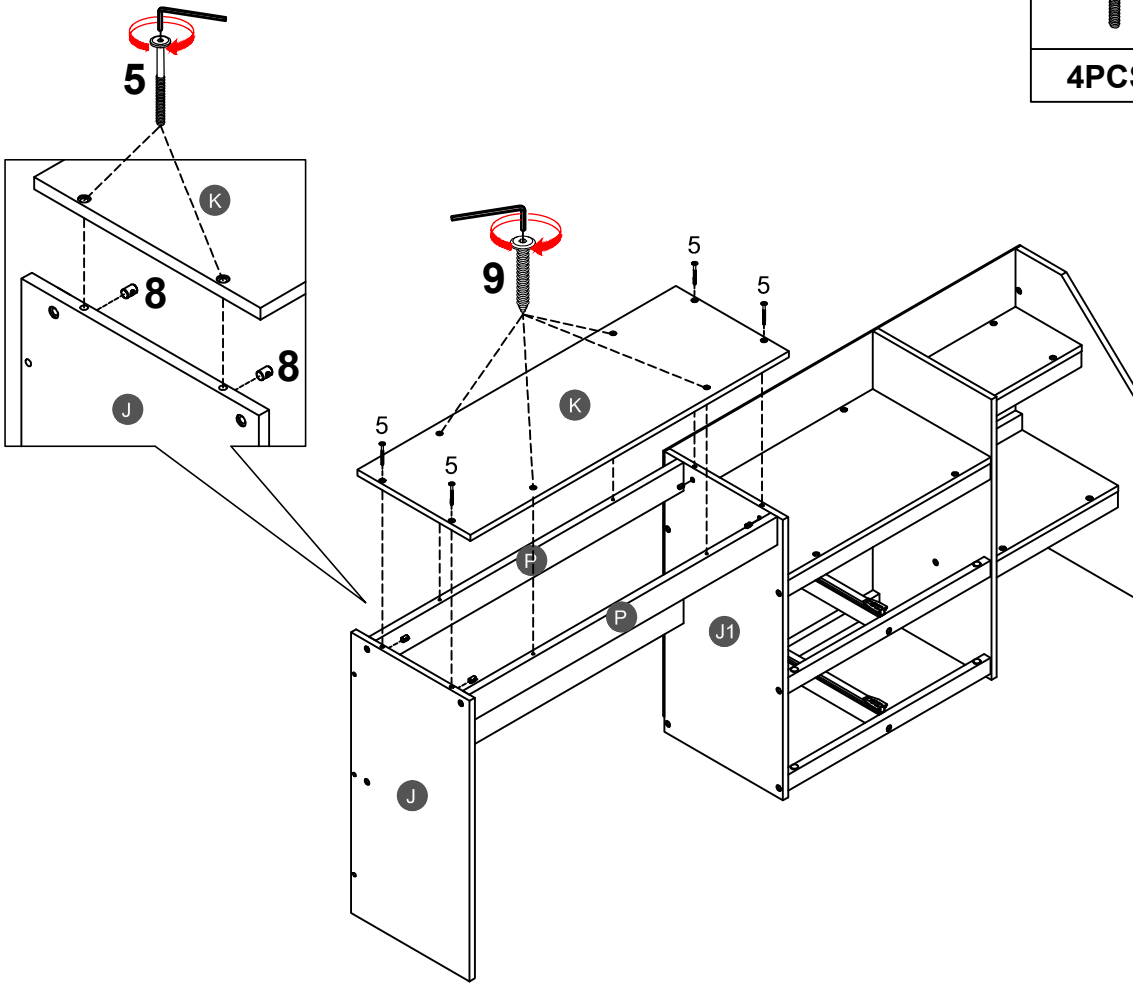

<b>5</b>		<b>8</b>	
<b>4PCS</b>		<b>4PCS</b>	
		<b>9</b>	
		<b>4PCS</b>	

**STEP 16:**

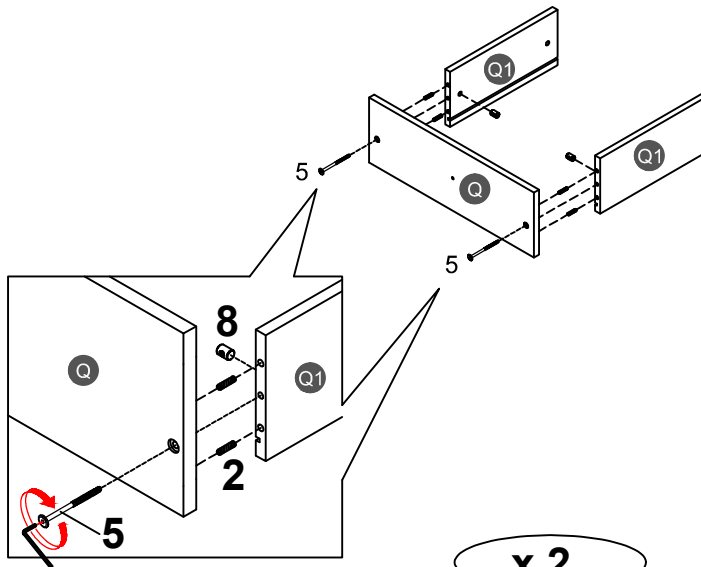



<b>2</b>		<b>5</b>	
<b>8PCS</b>		<b>4PCS</b>	
		<b>8</b>	
		<b>4PCS</b>	

**x 2**

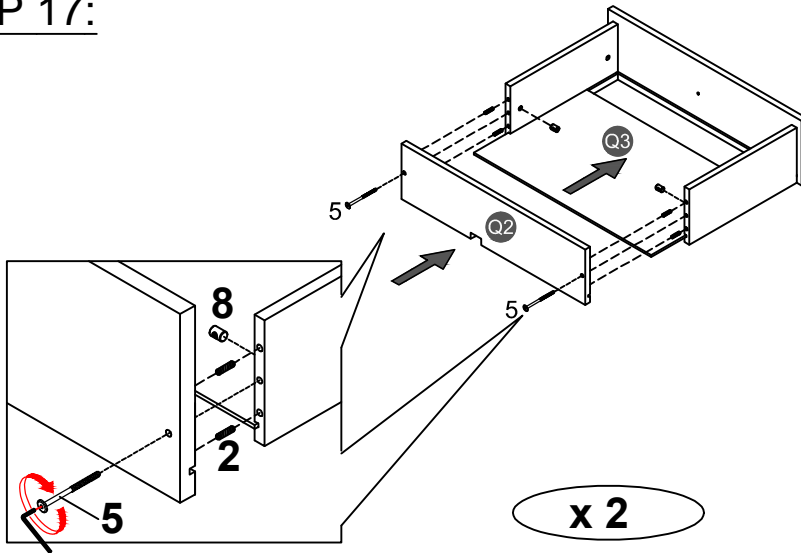

**STEP 17:**



<b>2</b>		<b>5</b>	
<b>8PCS</b>		<b>4PCS</b>	
		<b>8</b>	
		<b>4PCS</b>	

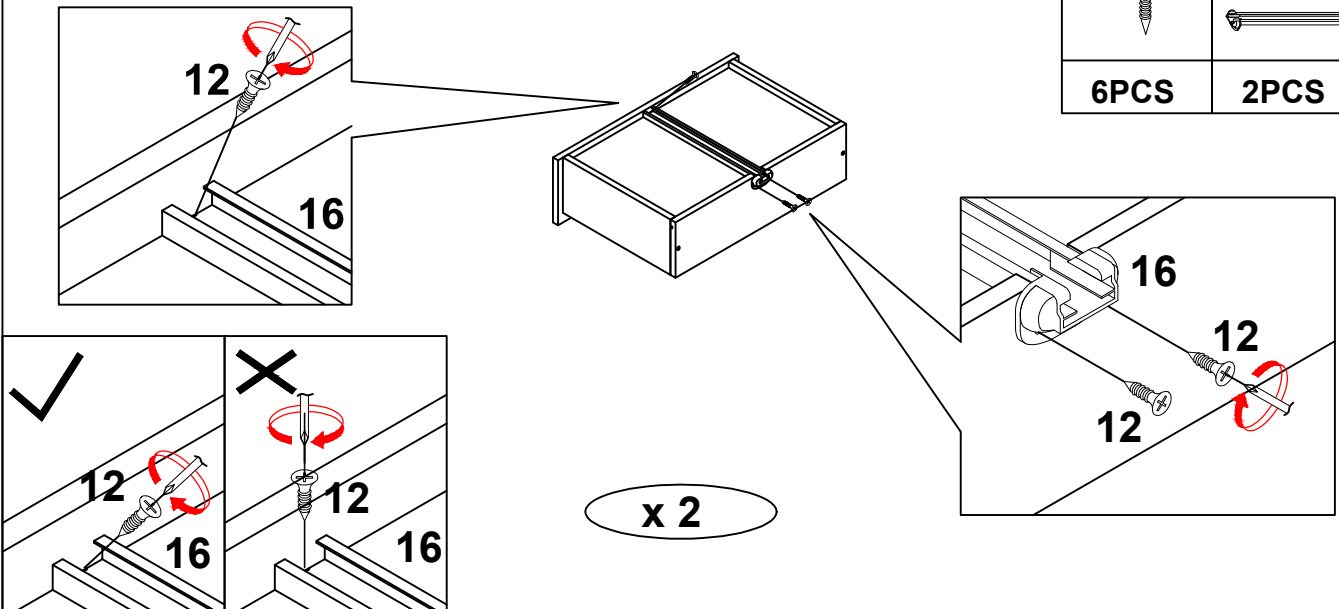

**STEP 18:**

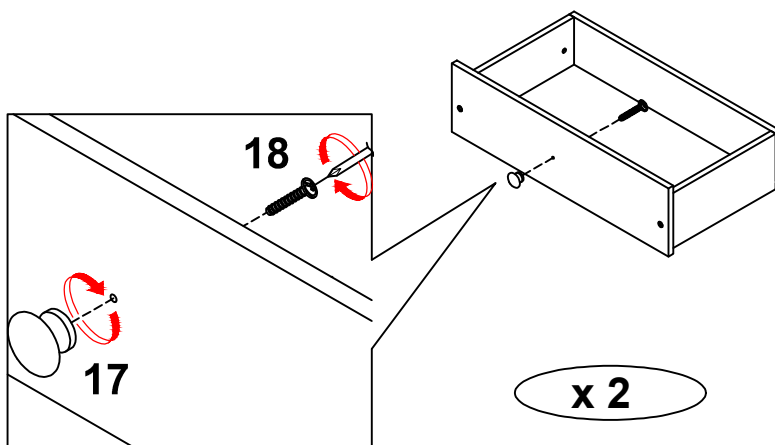

<b>12</b>		<b>16</b>	
<b>6PCS</b>		<b>2PCS</b>	

**STEP 19:**



<b>17</b>		<b>18</b>	
<b>2PCS</b>		<b>2PCS</b>	

**STEP 20:**

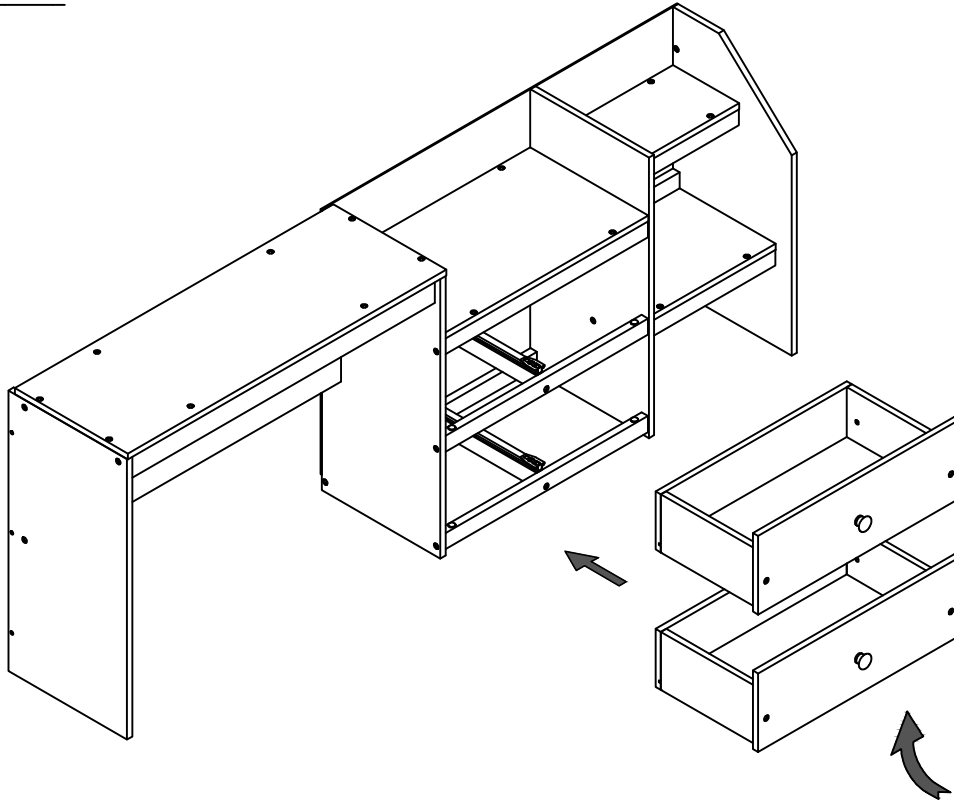

**STEP 21:**

<b>13</b>

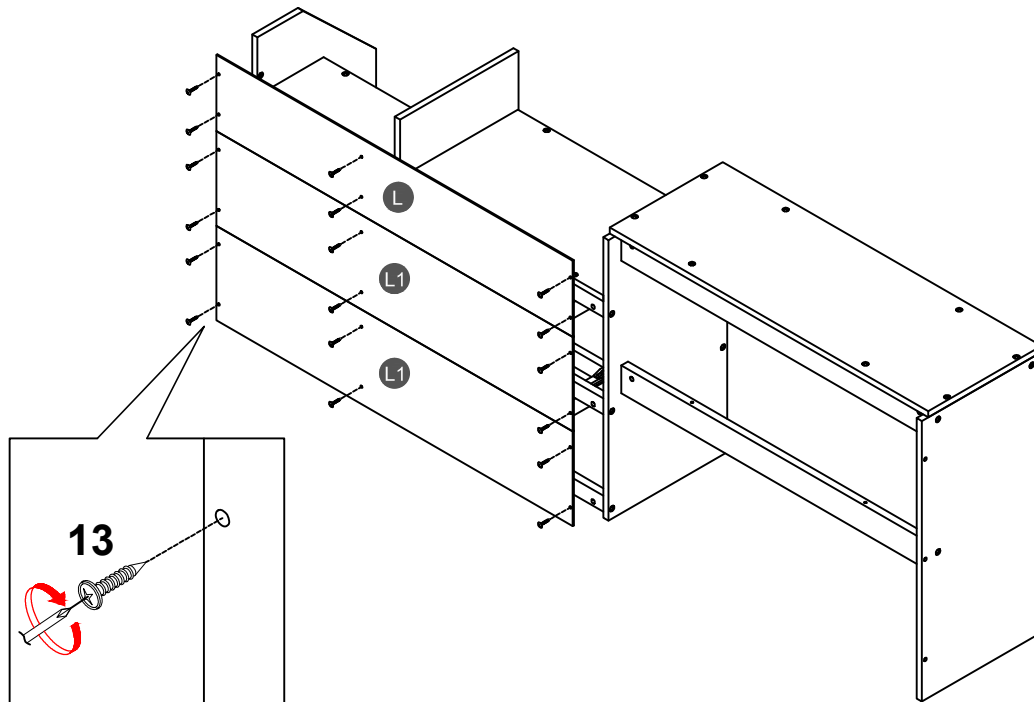
<b>18PCS</b>

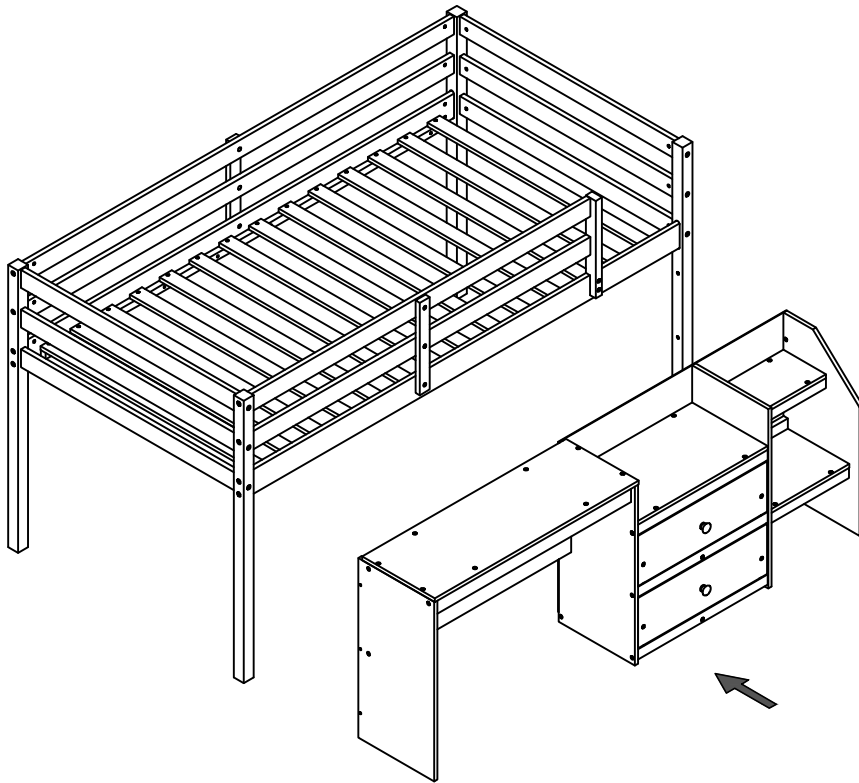

**STEP 22:**

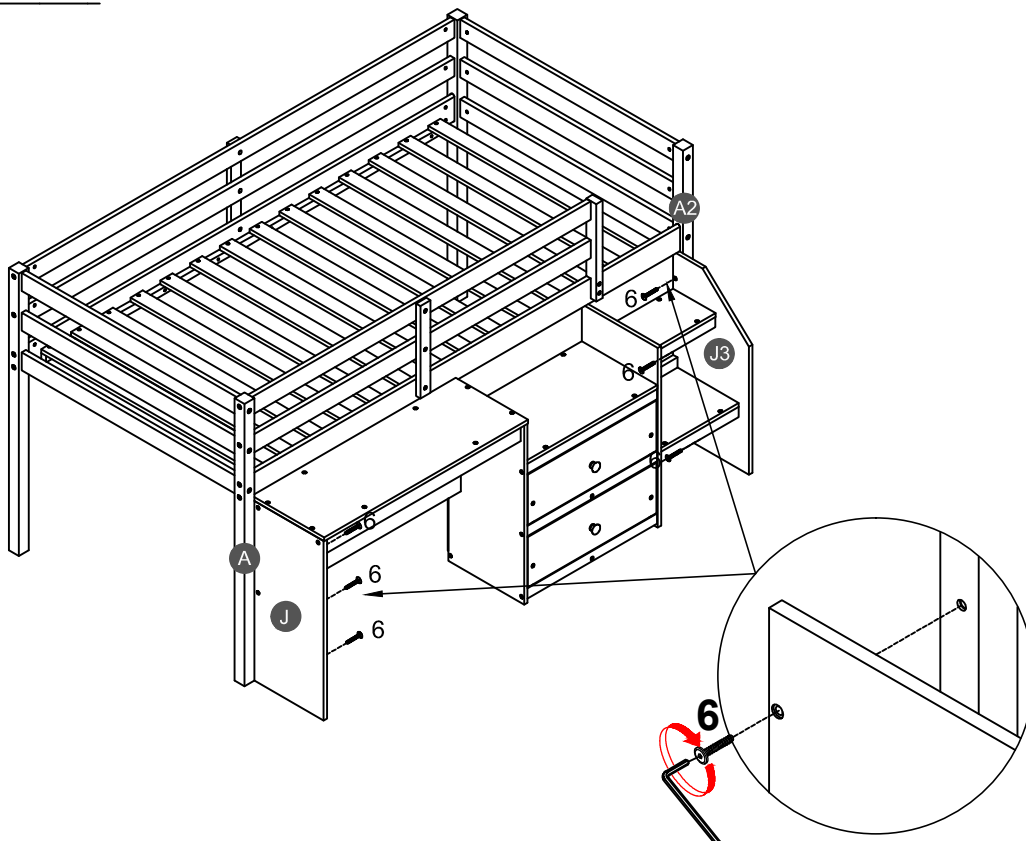

**STEP 23:**



6



6PCS



**STEP 24:**

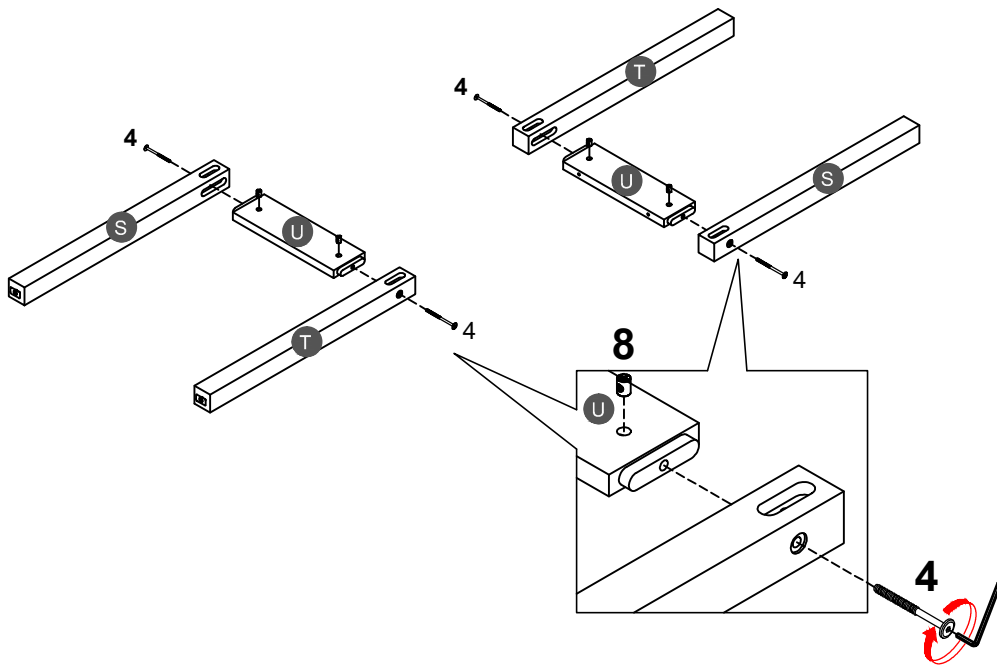

4



4PCS

8



4PCS

**STEP 25:**

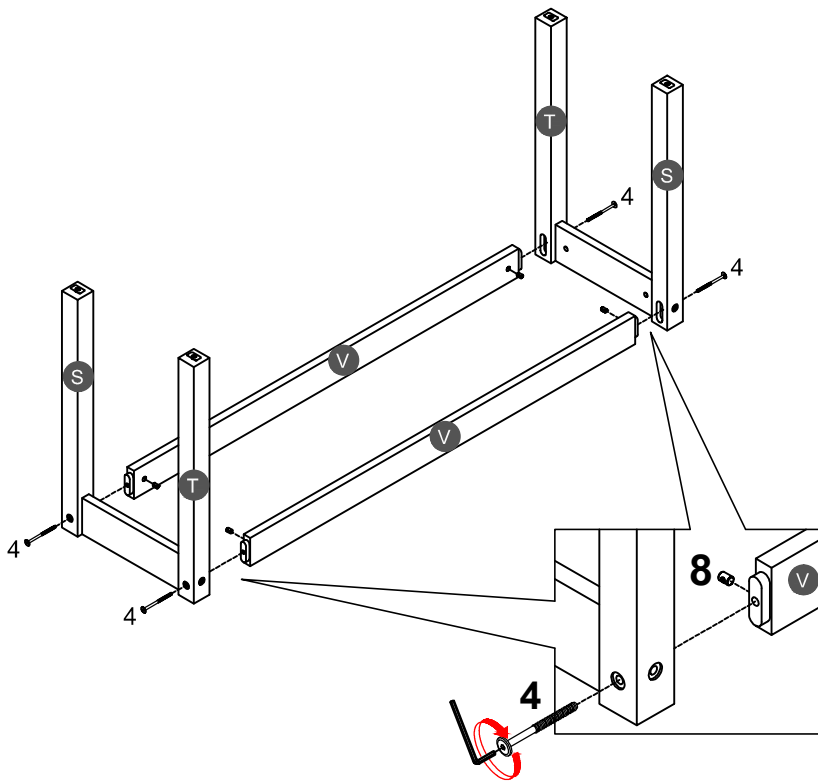

4



4PCS

8



4PCS

**STEP 26:**

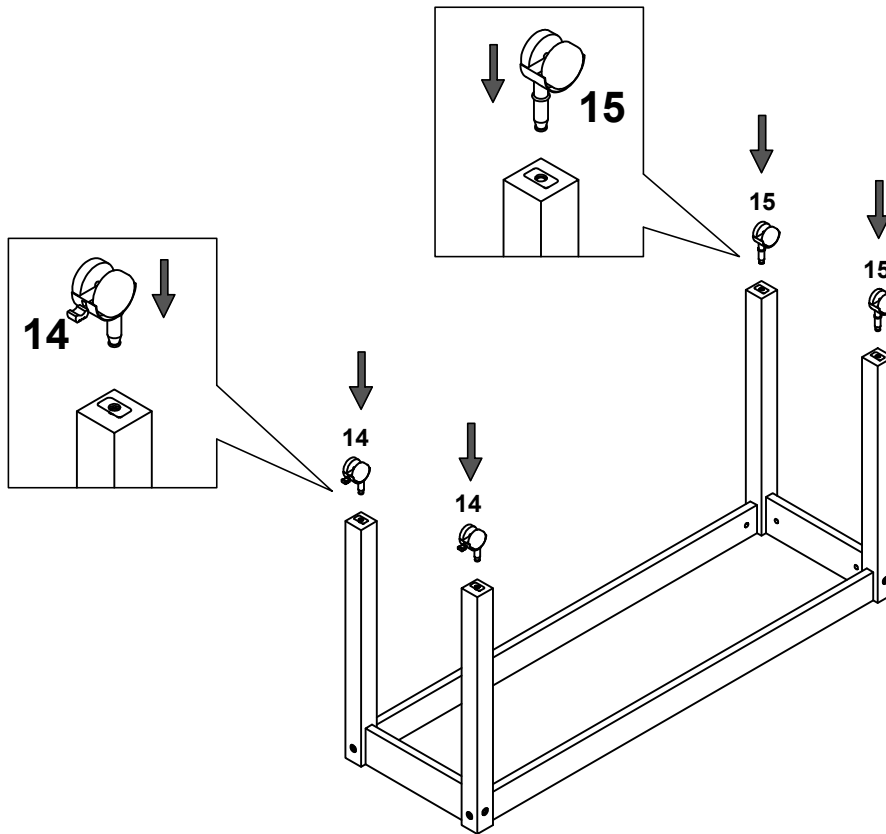

**2PCS**

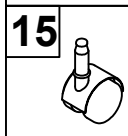

**2PCS**

**STEP 27:**

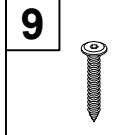
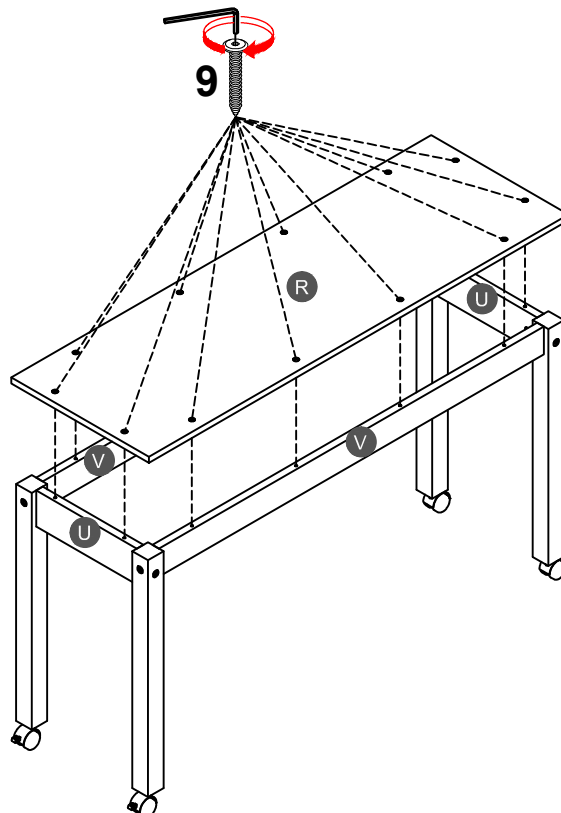

**12PCS**

**STEP 28:**

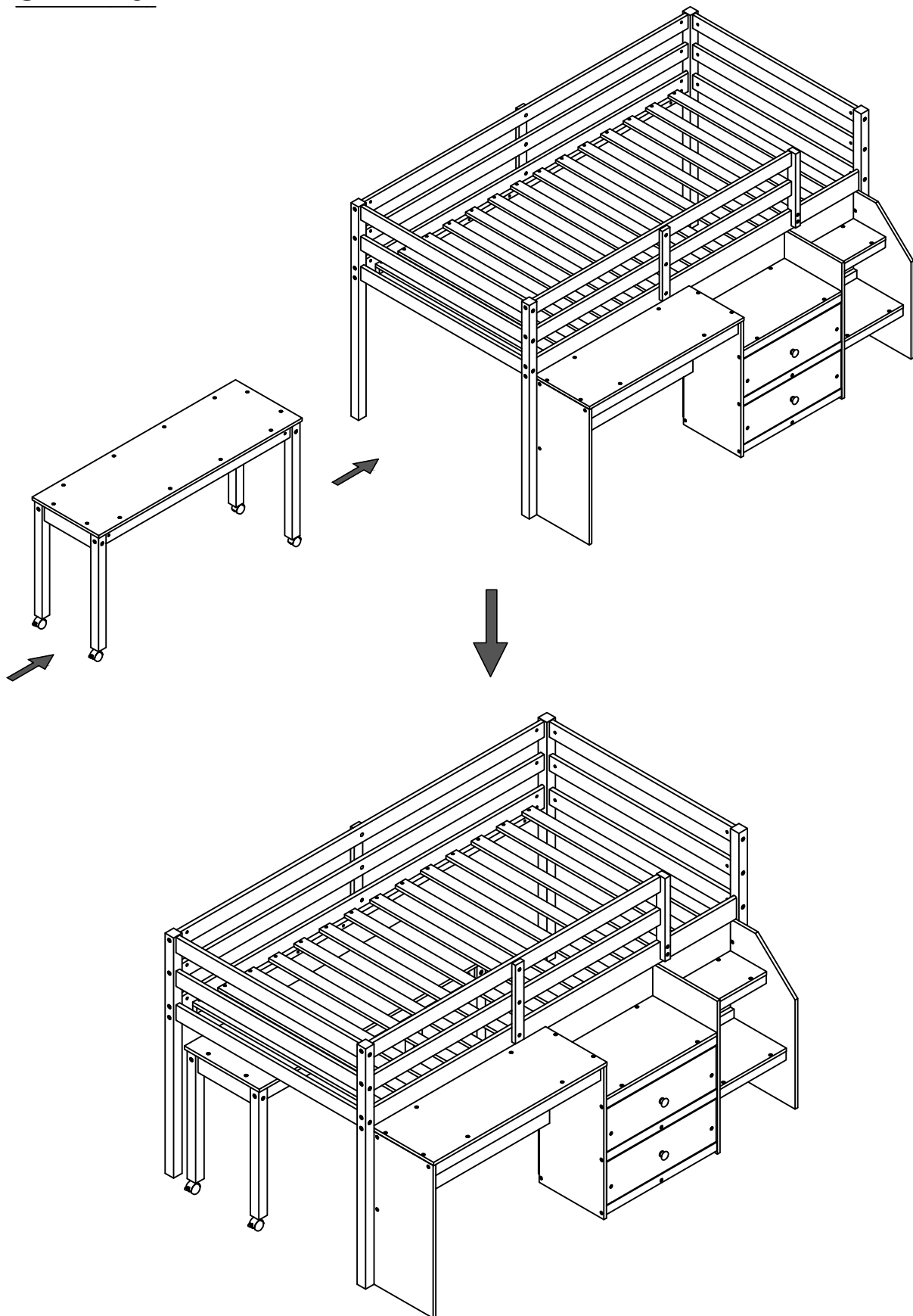

**Make sure to tighten all the screws of the bed.**