

ASSEMBLY INSTRUCTIONS
Item No : WF296333/34/35
Description : STORAGE BED WITH DRAWERS

Thank you for purchasing this quality product. Be sure to check all packing material carefully for small part that may have come loose inside the carton during shipment.

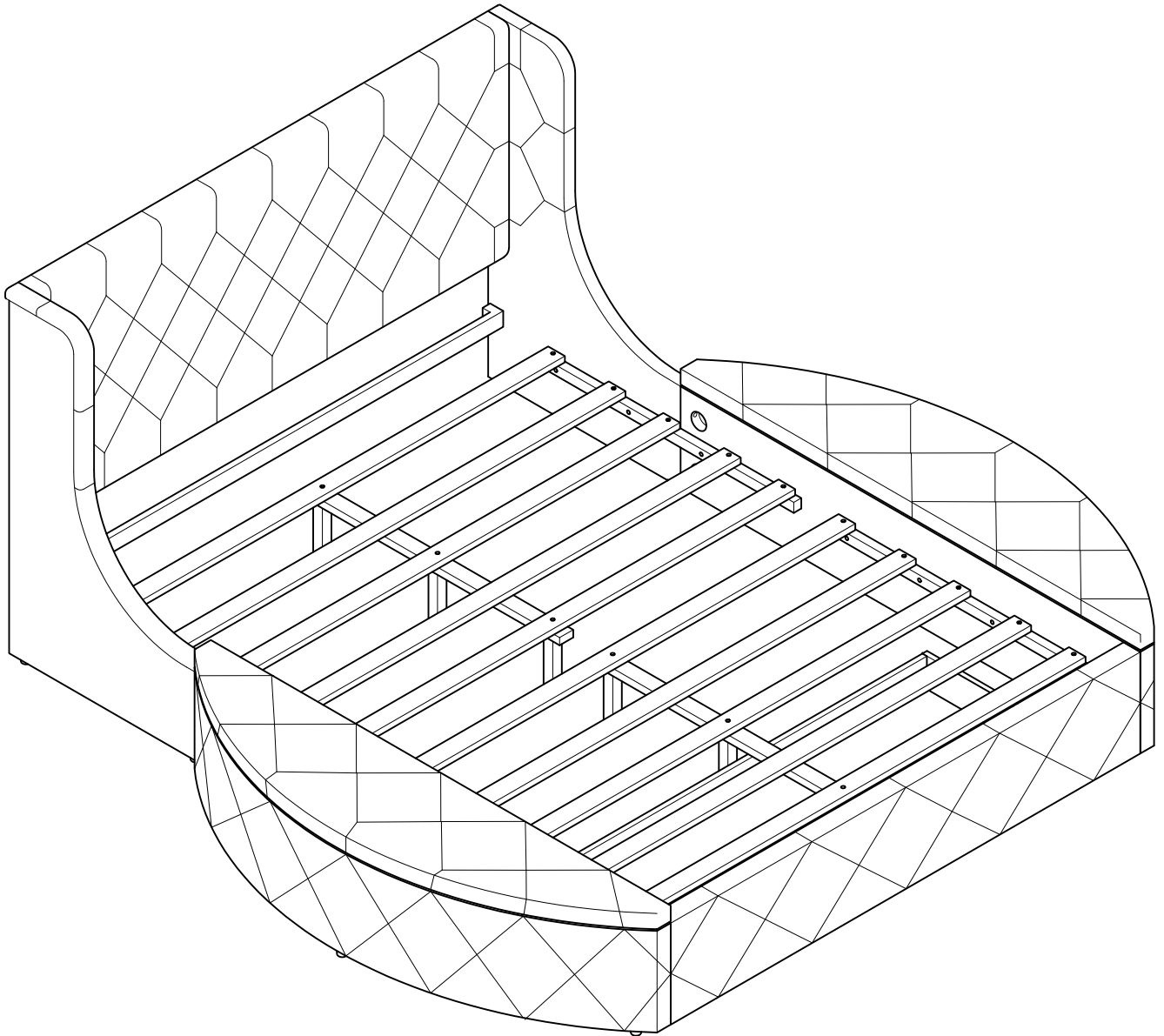



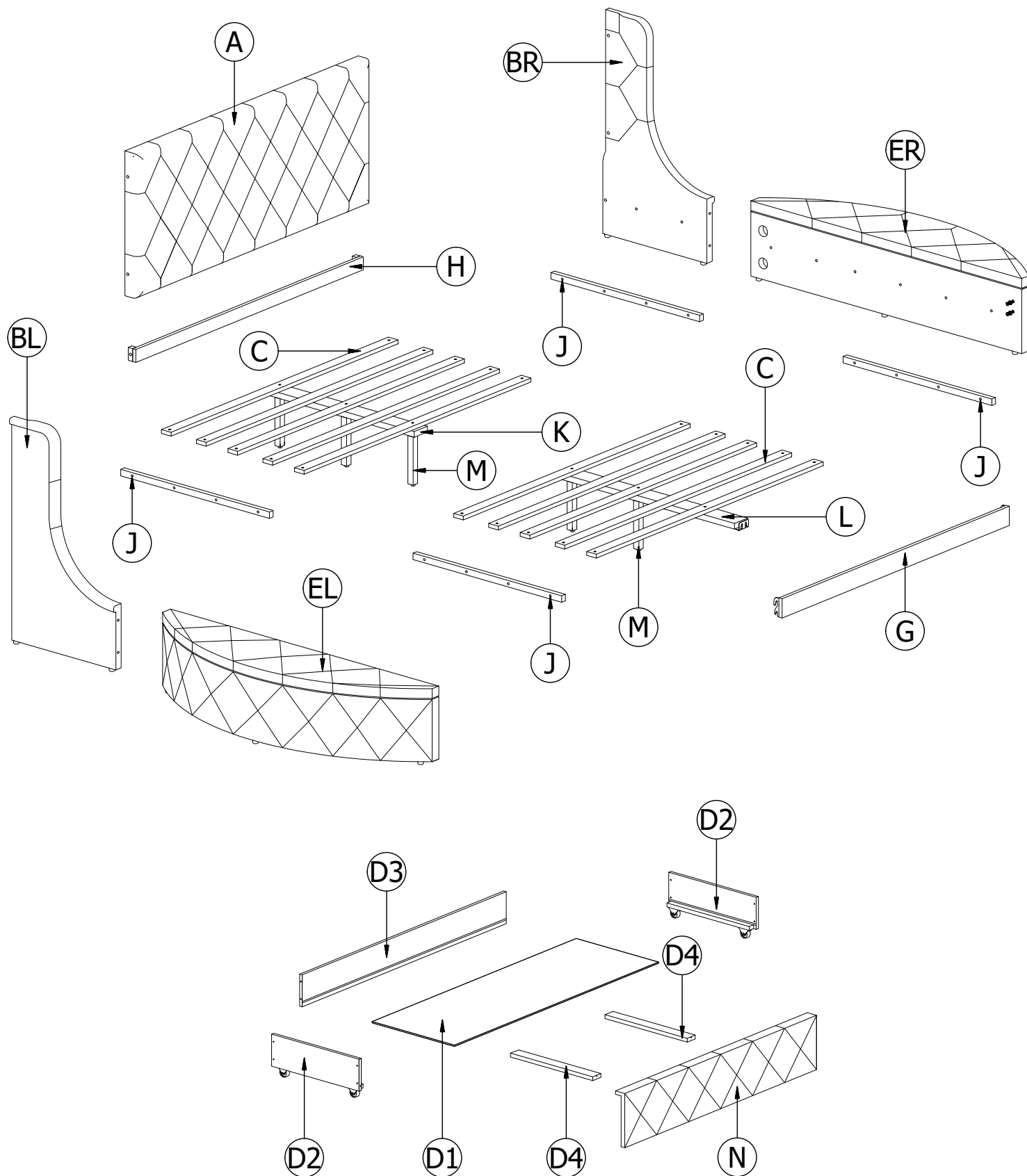

ASSEMBLY INSTRUCTIONS
Item No : WF296333/34/35
Description : STORAGE BED WITH DRAWERS





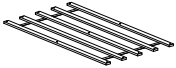

Thank you for purchasing this quality product. Be sure to check all packing material carefully for small part that may have come loose inside the carton during shipment.





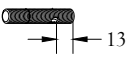
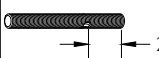

ASSEMBLY INSTRUCTIONS
Item No : WF296333/34/35
Description : STORAGE BED WITH DRAWERS





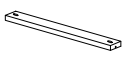
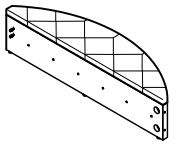

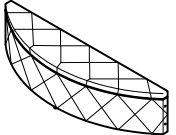
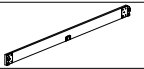
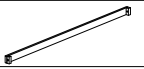
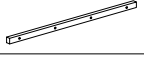
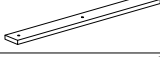
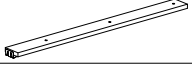

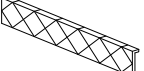

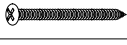
Thank you for purchasing this quality product. Be sure to check all packing material carefully for small part that may have come loose inside the carton during shipment.

PART LIST : WF296333			
No.	Description	Sketch	Quantity
A	Headboard panel		1PC
BL	Wing HB Left		1PC
BR	Wing HB Right		1PC
C	Slats Rolls		2SET
D1	Drawer Bottom		1PC

HARDWARE LIST : WF296333				
No.	Description	Sketch	Size	Quantity
Q	Bolt		Ø 5/16" * 2" L	2PCS
R	Spring Washer		Ø 5/16"	6PCS
S	Flat Washer		Ø 5/16"	6PCS
T	Thread Bolt		Ø 5/16" * 2-1/4" L	4PCS
U	Thread Bolt		Ø 5/16" * 3-1/2" L	4PCS
W	Hexagonal Nut		Ø 5/16"	4PCS
X	Open Wrench		M12	1PC
Y	Allen Key		M4 * 2-1/2" L	1PC

PART LIST : WF296334			
No.	Description	Sketch	Quantity
D2	Drawer Side		2PCS
D3	Drawer Back		1PC
D4	Support Bottom		2PCS
EL	Storage Rail Left		1PC

PART LIST : WF296335			
No.	Description	Sketch	Quantity
ER	Storage Rail Right		1PC
G	Footboard		1PC
H	Stretch		1PC
J	Support Rail		4PCS
K	Short Center Support Slats		1PC
L	Long Center Support Slats		1PC
M	Support Leg		5PCS
N	Drawer Front		1PC

HARDWARE LIST : WF296335				
No.	Description	Sketch	Size	Quantity
P	Screw		Ø 8 * 2-1/4" L	8PCS
O	Bolt		Ø 5/16" * 1-1/2" L	1PC
Q	Bolt		Ø 5/16" * 2" L	16PCS
R	Spring Washer		Ø 5/16"	17PCS
S	Flat Washer		Ø 5/16"	17PCS
V	Washer Semicircle		Ø 5/16" * 25L	4PCS
W	Hexagonal Nut		Ø 5/16"	4PCS
Z	Screw		Ø 8 * 1-1/4" L	24PCS
X	Open Wrench		M12	1PC
Y	Allen Key		M4 * 2-1/2" L	1PC

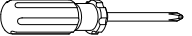
TOOLS REQUIRED (Not provided)	
	Screwdriver

ASSEMBLY INSTRUCTIONS
Item No : WF296333/34/35
Description : STORAGE BED WITH DRAWERS

Thank you for purchasing this quality product. Be sure to check all packing material carefully for small part that may have come loose inside the carton during shipment.

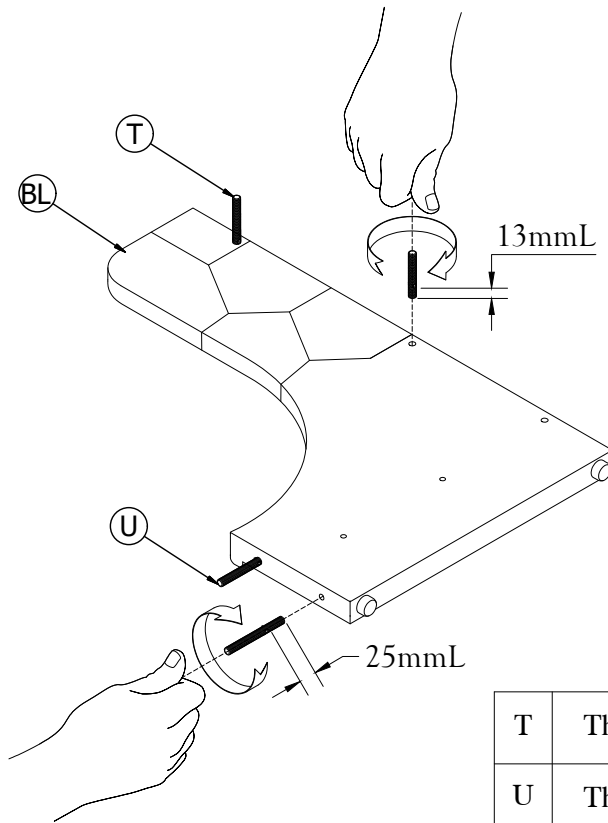

Step 1. Assemble the Thread Bolt(T) and (U), put onto pre-drilled holes Wing Headboard L/R(B) and secure by hand.

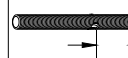

T	Thread Bolt	 13mmL	$\text{Ø } \frac{5}{16}'' * 2\frac{1}{4}''\text{L}$	4PCS
U	Thread Bolt	 25mmL	$\text{Ø } \frac{5}{16}'' * 3\frac{1}{2}''\text{L}$	4PCS

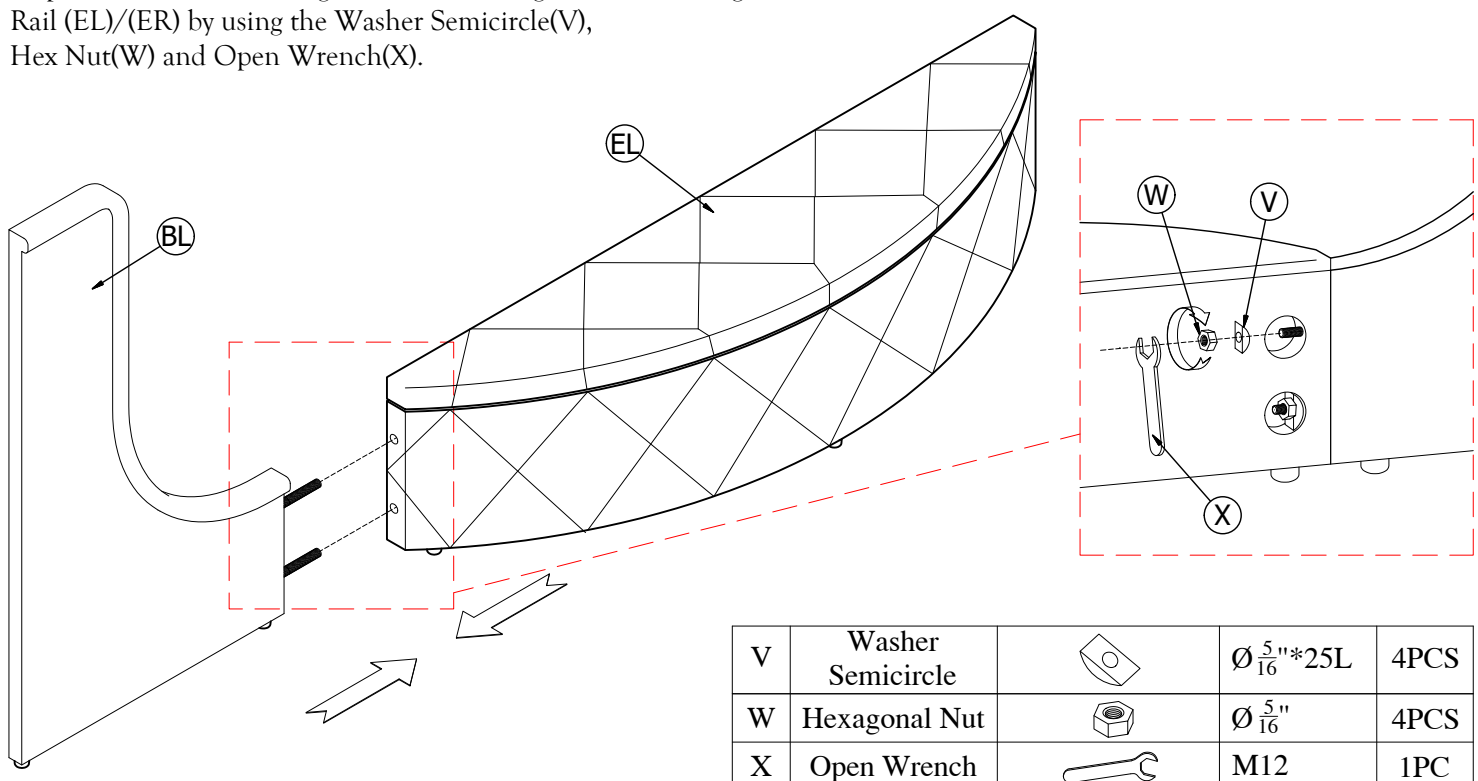
Step 2. Assemble the Wing HB (BL)/(BR) together with Storage Rail (EL)/(ER) by using the Washer Semicircle(V), Hex Nut(W) and Open Wrench(X).







V	Washer Semicircle		$\text{Ø } \frac{5}{16}'' * 25\text{L}$	4PCS
W	Hexagonal Nut		$\text{Ø } \frac{5}{16}''$	4PCS
X	Open Wrench		M12	1PC

ASSEMBLY INSTRUCTIONS
Item No : WF296333/34/35
Description : STORAGE BED WITH DRAWERS

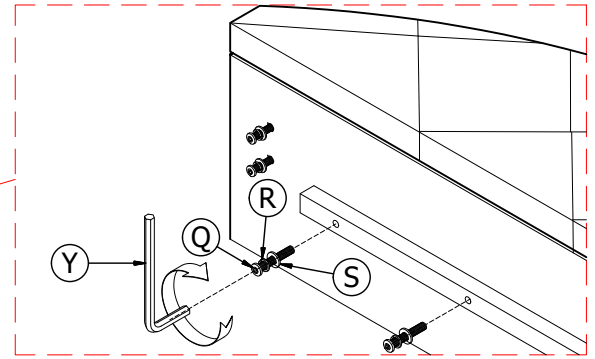
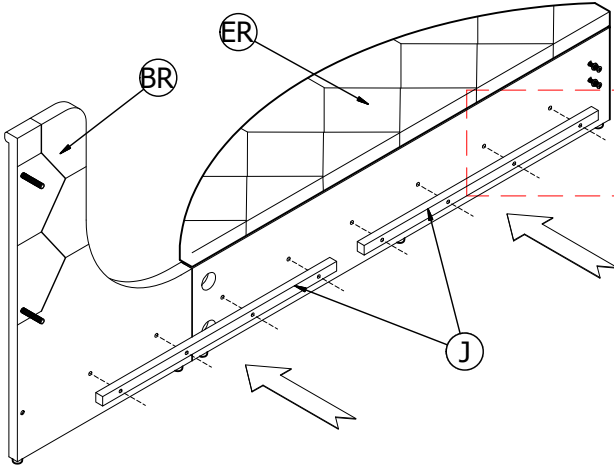
Thank you for purchasing this quality product. Be sure to check all packing material carefully for small part that may have come loose inside the carbon during shipment.







Step 3. Assemble the Support Rail(J) together with cluster Storage Rail (EL)/(ER), WingL/R(B), the by using the Bolt(Q), Spring Washer(R), Flat Washer(S) and Allen Key(Y).

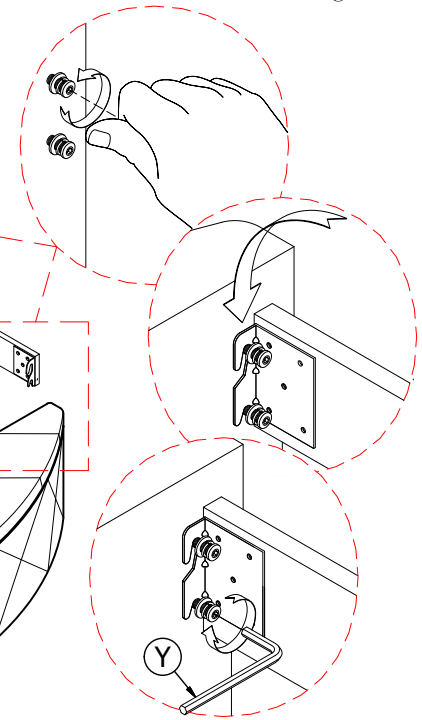
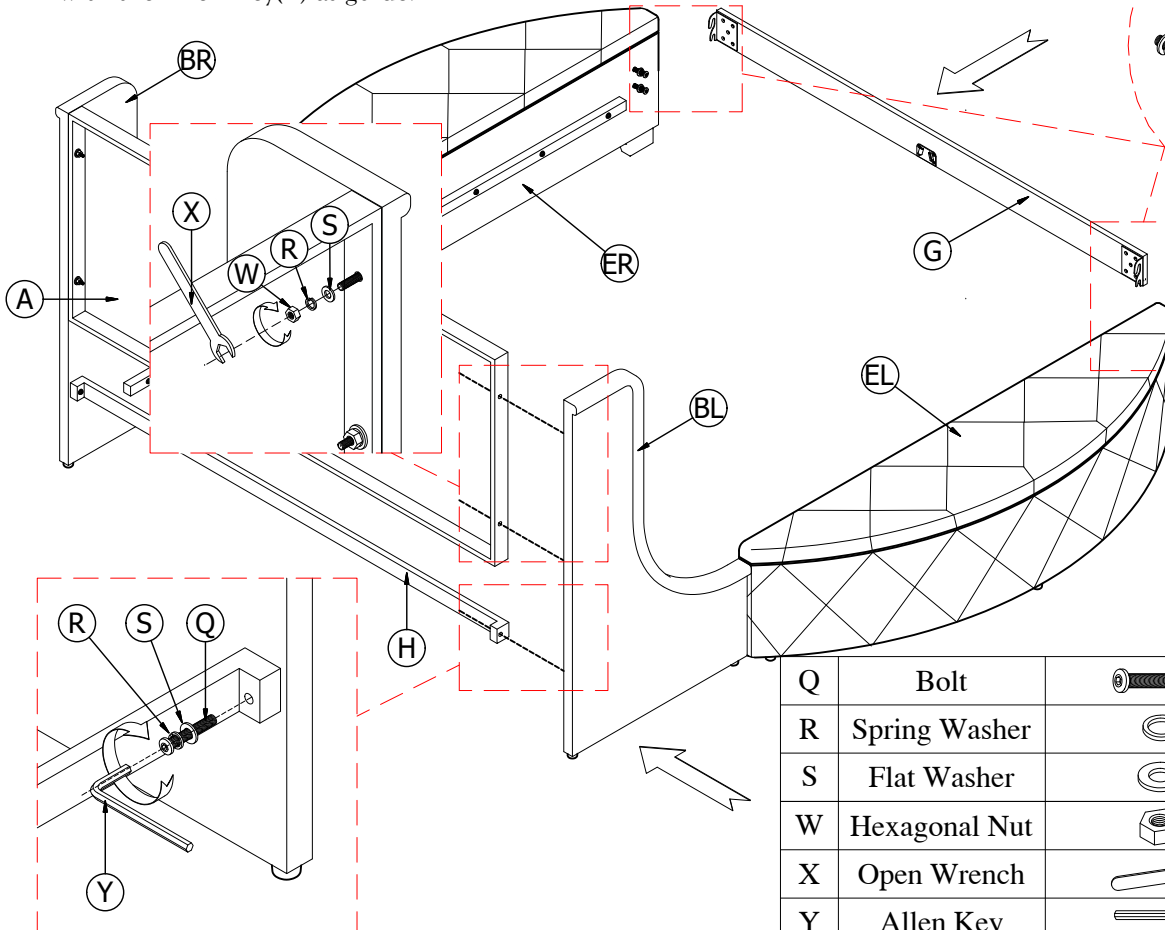

Q	Bolt		$\text{Ø } \frac{5}{16}'' \times 2'' \text{L}$	16PCS
R	Spring Washer		$\text{Ø } \frac{5}{16}''$	16PCS
S	Flat Washer		$\text{Ø } \frac{5}{16}''$	16PCS
Y	Allen Key		$\text{M4} \times 2\text{-}\frac{1}{2}'' \text{L}$	1PC

Step 4. Assembled the Headboard panel(A) to the Wing HB (BL)/(BR), with two pre-assembled threaded rods, by using the Flat Washer(S) Flat Washer (R), Hex Nut(W), tighten them with the Open Wrench(X) as guide. Also, give the Stretch(H), the by using the Bolt(Q), Spring Washer(R), Flat Washer(S) and Allen Key(Y) as guide. Next, put the Footboard(G) to Storage Rail (EL)/(ER). Before performing this step, please loosen the bolts of the Storage Rail L/R(E), intended to hook metal Footboard(G) securely set to the bolt. Finally, tighten them with the Allen Key(Y) as guide.



Q	Bolt		$\text{Ø } \frac{5}{16}'' \times 2'' \text{L}$	2PCS
R	Spring Washer		$\text{Ø } \frac{5}{16}''$	6PCS
S	Flat Washer		$\text{Ø } \frac{5}{16}''$	6PCS
W	Hexagonal Nut		$\text{Ø } \frac{5}{16}''$	4PCS
X	Open Wrench		M12	1PC
Y	Allen Key		$\text{M4} \times 2\text{-}\frac{1}{2}'' \text{L}$	1PC



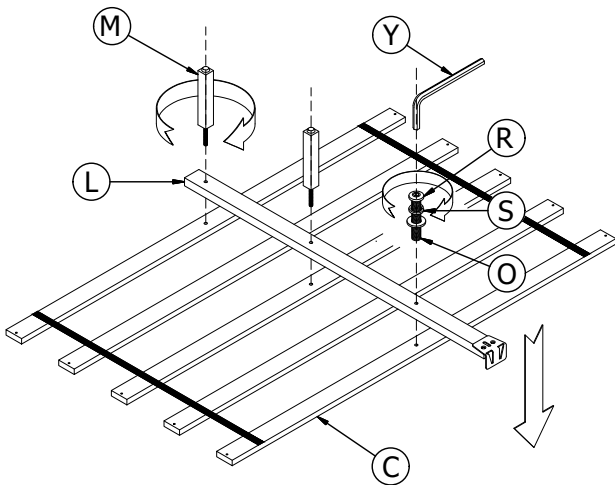
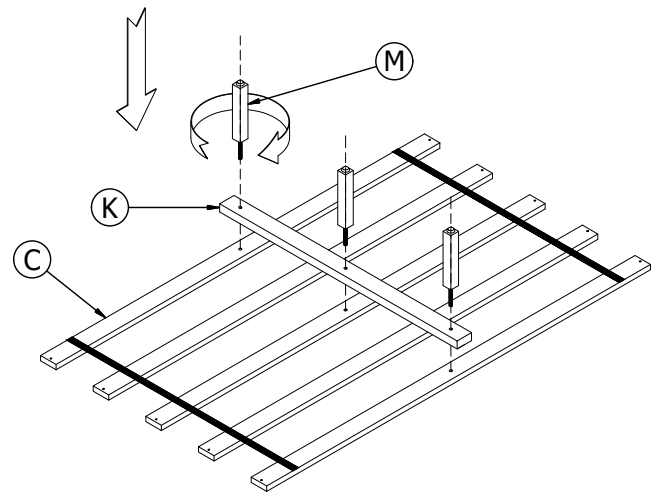

ASSEMBLY INSTRUCTIONS
Item No : WF296333/34/35
Description : STORAGE BED WITH DRAWERS

Thank you for purchasing this quality product. Be sure to check all packing material carefully for small part that may have come loose inside the carton during shipment.

Step 5. Set Slat roll(C), link pre-wire up. Next, place the Short center support slats(K), align the drill holes. At the same time, use the Support leg(M) to pass through the holes on the Short center support slats(K) one by one, to link through the Slat roll(C) and tighten them together.



Step 6. Set Slat roll(C), link pre-wire up. Next, place the Long center support slats(L), align the drill holes. At the same time, use the Support leg(M) to pass through the holes on the Long center support slats(L) one by one, to link through the Slat roll(C) and tighten them together. Next the by using the Bolt(O), Spring Washer(R), Flat Washer(S) and Allen Key(Y).

O	Bolt		$\text{Ø} \frac{5}{16} \text{''} * 1\text{-}\frac{1}{2} \text{''} \text{L}$	1PC
R	Spring Washer		$\text{Ø} \frac{5}{16} \text{''}$	1PC
S	Flat Washer		$\text{Ø} \frac{5}{16} \text{''}$	1PC
Y	Allen Key		$\text{M4} * 2\text{-}\frac{1}{2} \text{''} \text{L}$	1PC

Step 7. Put the two Slat roll clusters on the Storage Rail (EL)/(ER) of the bed to be neat, then tighten they are by Screws(Z).

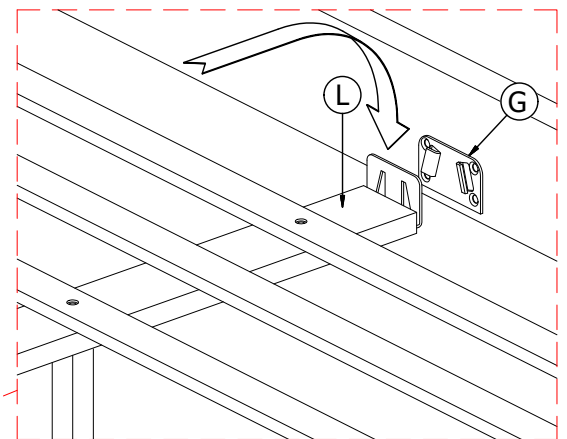
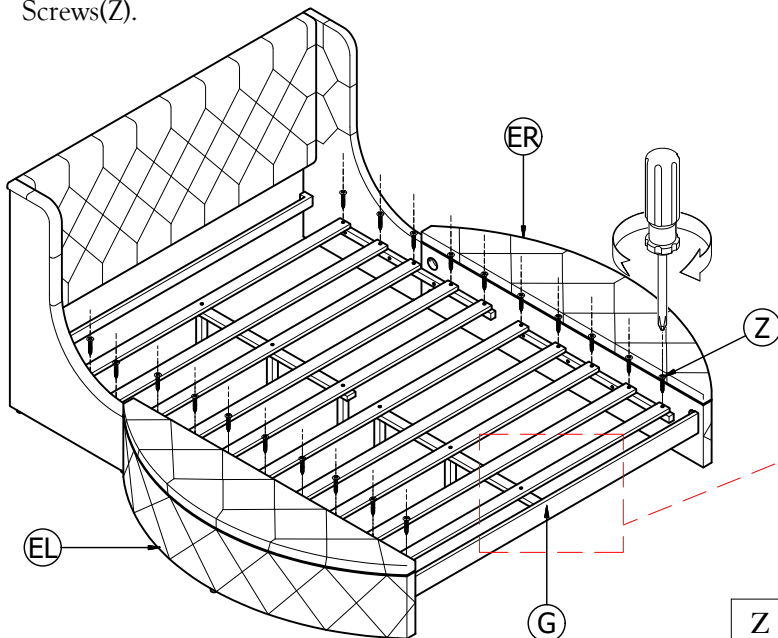



Z	Screw		$\text{Ø} 8 * 1\text{-}\frac{1}{4} \text{''} \text{L}$	20PCS
---	-------	---	--	-------

ASSEMBLY INSTRUCTIONS
Item No : WF296333/34/35
Description : STORAGE BED WITH DRAWERS

Thank you for purchasing this quality product. Be sure to check all packing material carefully for small part that may have come loose inside the carton during shipment.

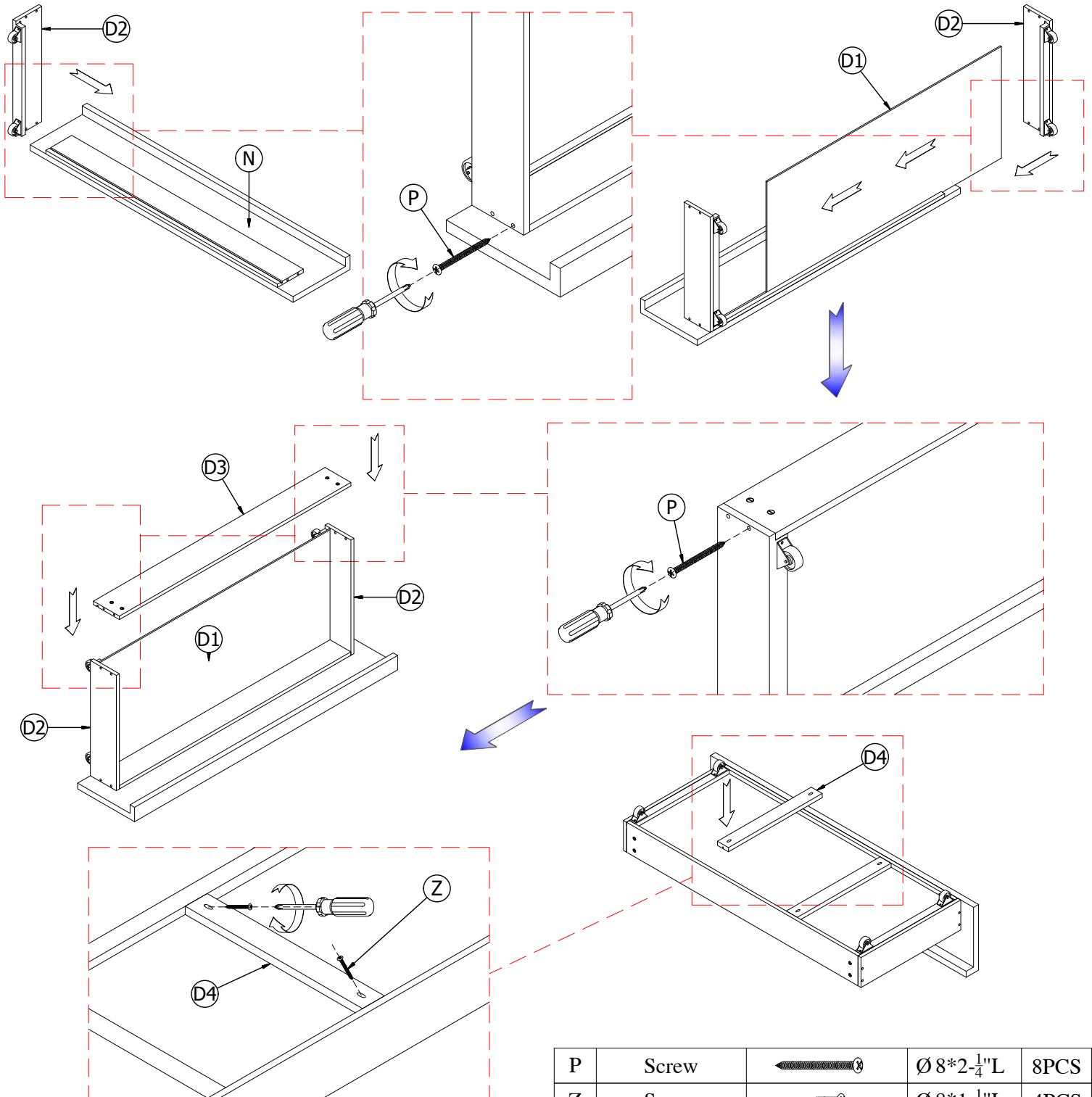
Step 8. Place the Drawer side plate(D2) with mount wheels to up on top of the back of Face Cushion(N), aligning the drilled holes, by using the Screws(P) please in to the small holes available, use screwdriver tighten them together. Next, give turn the Drawer bottom plate(D1) and the Drawer side Plate(D2) rest add also put on top of the back of face Cushion(N), also by using the Screws(P) please in to the small holes available, use screwdriver tighten them together. Next step, pass Drawer backs plate(D3) to in the Drawer side plate(D2) and Drawer bottom plate(D1). Aligning the drilled holes, by the Screws(P) in to the small holes available, use screwdriver tighten them together. Finally, put the Bottom support bar(D4), use please Screws(Z) in put to the small holes, use screwdriver, tighten them together.



P	Screw		Ø 8*2-¼" L	8PCS
Z	Screw		Ø 8*1-¼" L	4PCS

ASSEMBLY INSTRUCTIONS
Item No : WF296333/34/35
Description : STORAGE BED WITH DRAWERS

Thank you for purchasing this quality product. Be sure to check all packing material carefully for small part that may have come loose inside the carton during shipment.

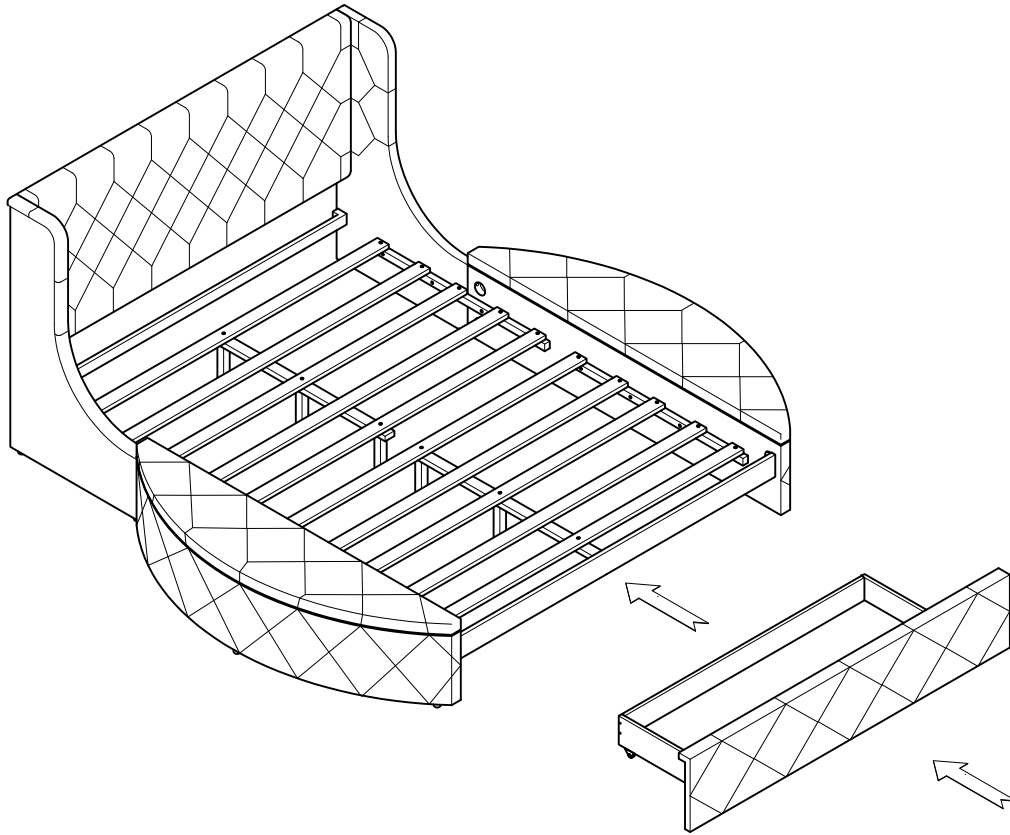

Step 9. Push drawers under the bottom of Bed.

