

ASSEMBLY INSTRUCTION

SKU CODE: (WF286877-WF286878-WF286879)

This set is included 3 boxes if don't receive full 3 boxes please contact our customer service team

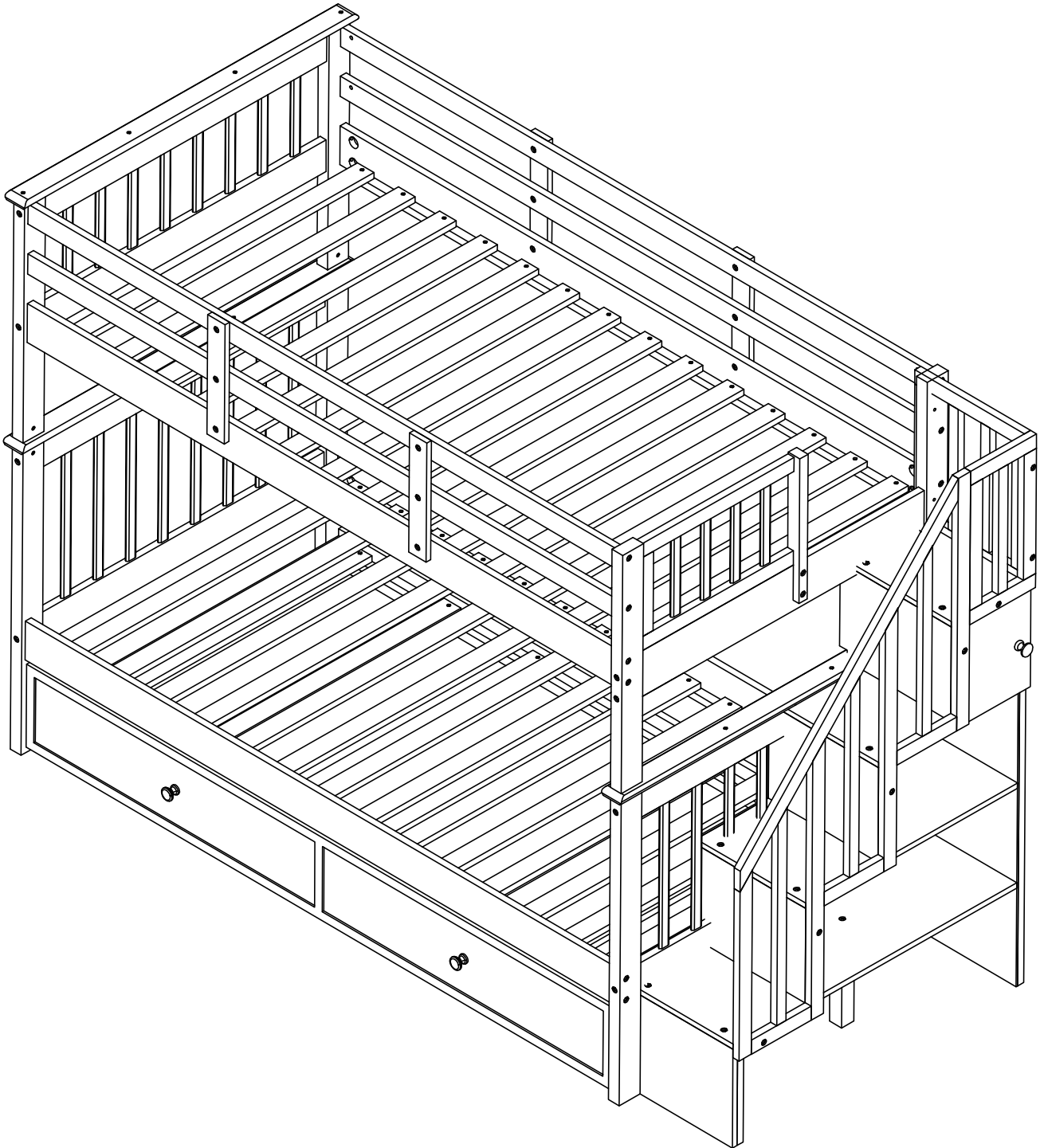

! SAFETY WARNINGS !

1. This bed is designed for use only mattress (es) meeting the following specifications on the upper bunk, and lower bunk

Upper bed

Bed Type	Length	Width	Thickness
<i>Twin Standard</i>	<i>74" - 75"</i>	<i>38 1/2"</i>	<i>6" max</i>

Lower bed







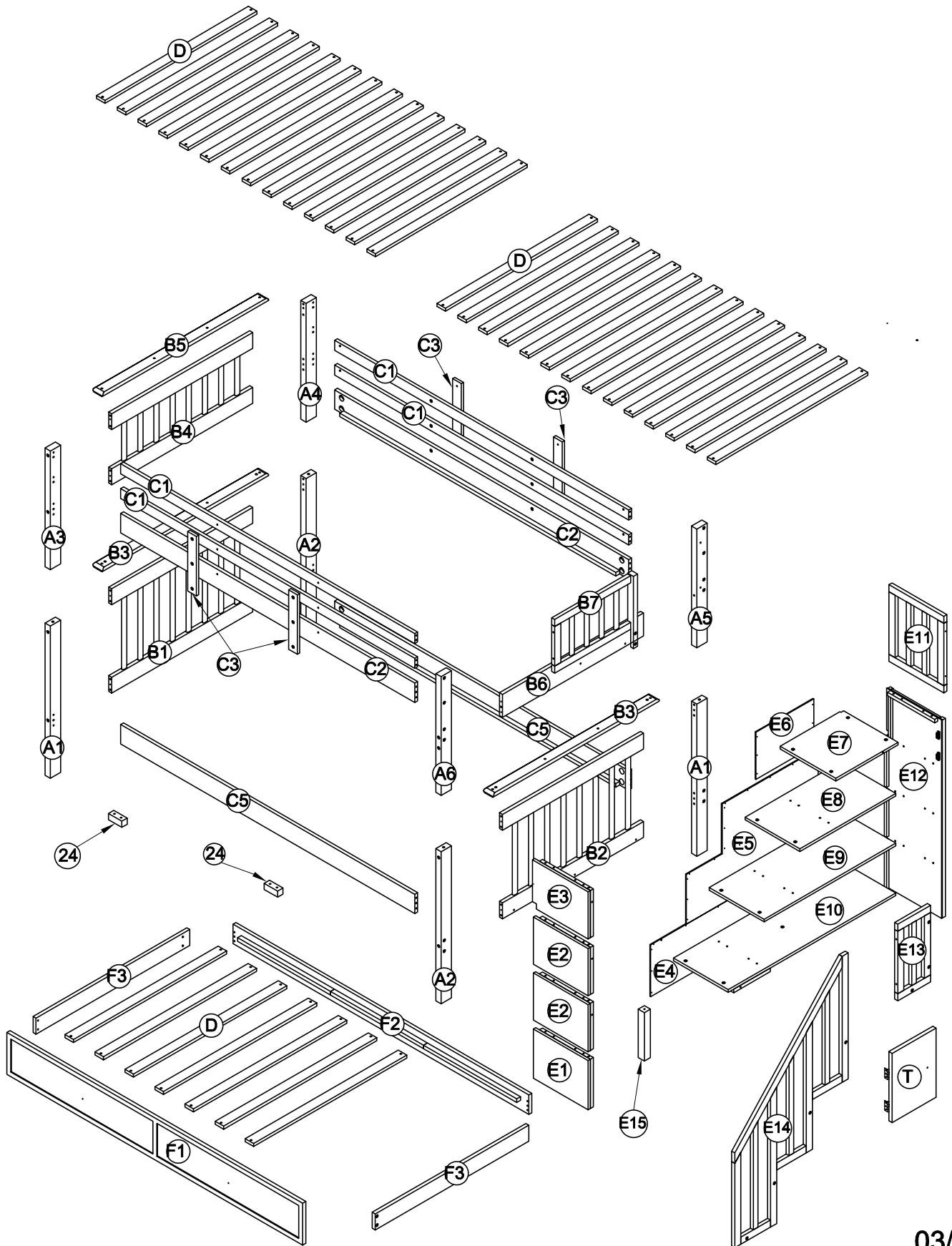



Bed Type	Length	Width	Thickness
<i>Twin Standard</i>	<i>74" - 75"</i>	<i>38 1/2"</i>	<i>8" max</i>

2. Replacement parts, including additional guardrails, maybe obtained from any of our (GIGACLOUD TECHNOLOGY (USA) INC. 18961 ARENTH AVENUE CITY OF INDUSTRY, CA, 91748) dealers
3. Follow the information on the warnings appearing on the upper bunk bed end structure and on the carton. Do not remove warning label from bed
4. Always use the recommended size mattresses or mattress supports, or both, to help prevent the likelihood of entrapment or falls.
5. Surface of mattress must be at least 5" (127mm) below the upper edge of guardrails
6. Do not allow children under 6 years of age to use the upper bunk.
7. Periodically check and ensure that the guardrail, ladder, and other components are in their proper position, free from damage, and that all connectors are tight.
8. Do not allow horseplay on or under the bed and prohibit jumping on the bed.
9. Always use the ladder for entering and leaving the upper bunkAlways use the ladder for entering and leaving the upper bunk.
10. Do not use substitute part. Contact the manufacture or dealer for replacement part
11. Use of a night light may provide added safety precaution for a child using the upper bunk..
12. Always use guardrails on both long sides of the upper bunk. If the bunk bed will be placed next to the wall, the guardrail that runs the full length of the bed should be placed against the wall to prevent entrapment between the bed and wall.
13. The use of water or sleep flotation mattresses is prohibited
14. **STRANGULATION HAZARD** - Never attach or hang items to any part of the bunk bed that are not designed for use with the bed; for example, but not limited to, hook, belts and jump ropes
15. Keep these instruction for future reference
16. Prohibit more than one person on upper bunk
17. We recommend assembling your bunk bed on the shipping carton to protect your floor or carpet
18. Be certain all staples are out of the box before beginning assembly on the shipping carton.

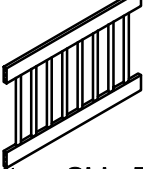
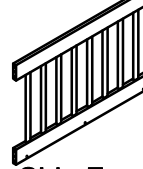
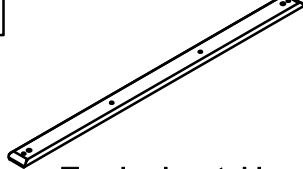
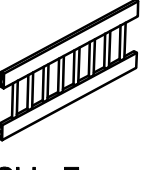

ASSEMBLY INSTRUCTION

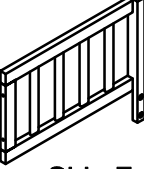
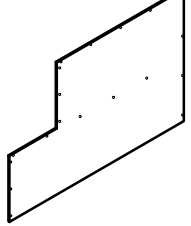
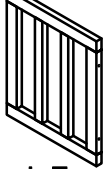
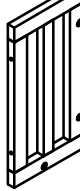

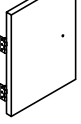

Part List(WF286877)-Hardware List

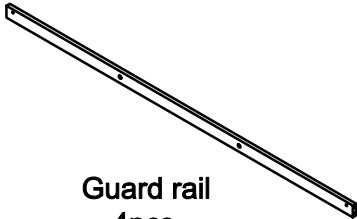
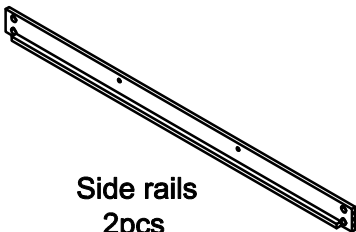
<p>A1</p>  <p>Bottom legs 2 pcs</p>	<p>A2</p>  <p>Bottom legs 2 pcs</p>	<p>A3</p>  <p>Upper leg 1 pc</p>
<p>A4</p>  <p>Upper leg 1 pc</p>	<p>A5</p>  <p>Upper leg 1 pc</p>	<p>A6</p>  <p>Upper leg 1 pc</p>
<p>B1</p>  <p>Bottom Side Frame(Left) 1 pc</p>	<p>B2</p>  <p>Bottom Side Frame(Right) 1 pc</p>	<p>B3</p>  <p>Top horizontal bar 2pcs</p>
<p>B4</p>  <p>Upper Side Frame(Left) 1 pc</p>	<p>B5</p>  <p>Top horizontal bar 1pcs</p>	<p>B6</p>  <p>Top horizontal bar 1pcs</p>
<p>B7</p>  <p>Upper Side Frame 1pc</p>	<p>E5</p>  <p>Side panel 1pc</p>	<p>E11</p>  <p>Back Frame 1pc</p>
<p>E13</p>  <p>Side Frame 1pc</p>	<p>E14</p>  <p>Side Frame 1pc</p>	<p>T</p>  <p>Door 1pc</p>

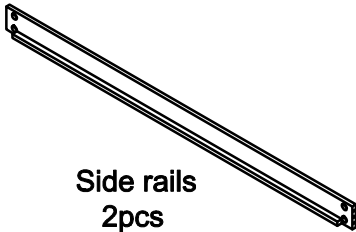
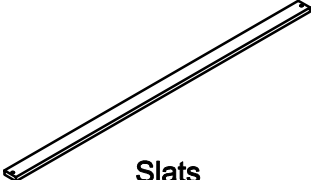
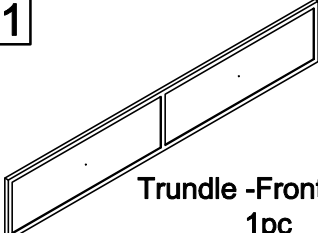
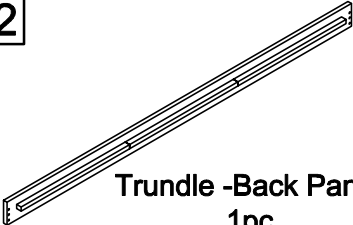
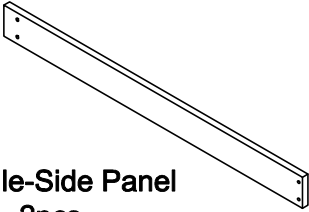



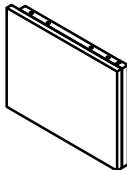
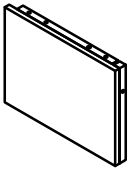
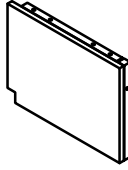
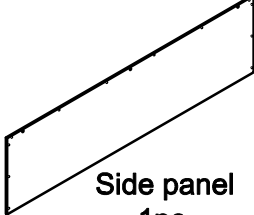
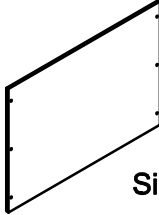
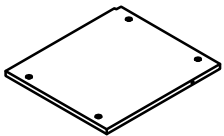
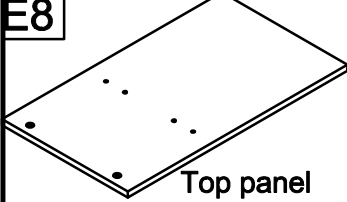
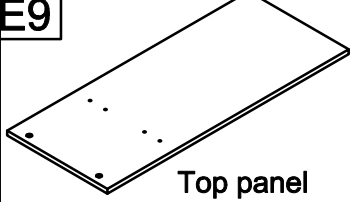
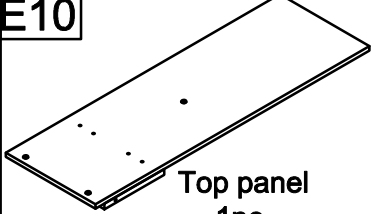

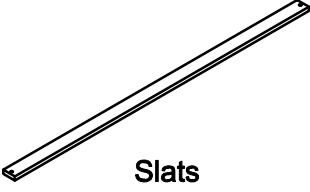



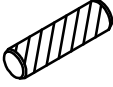



Part List(WF286878)

C1  Guard rail 4pcs	C2  Side rails 2pcs	C3  Vertical guard rails 4pcs
C5  Side rails 2pcs	D  Slats 7 pcs	F1  Trundle -Front Panel 1pc
F2  Trundle -Back Panel 1pc	F3  Trundle-Side Panel 2pcs	

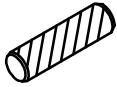
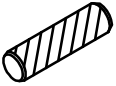

Part List(WF286879)

E1  Front panel 1 pc	E2  Front panels 2pcs	E3  Front panel 1pc
E4  Side panel 1pc	E6  Side panel 1pc	E7  Top panel 1pc
E8  Top panel 1pc	E9  Top panel 1pc	E10  Top panel 1pc
E12  Back Frame 1pc	E15  Support Bar 1pc	D  Slats 28 pcs

Hardware List

<p>1</p>  <p>Screws 1/4" x100 16pcs</p>	<p>2</p>  <p>Ø10 x 40 mm Wood dowel 42pcs</p>	<p>3</p>  <p>M4 x 30 mm Wood Screws 86pcs</p>
<p>4</p>  <p>Ø1/4" x 80 mm Hex-Head bolts 24pcs</p>	<p>6</p>  <p>Allen Key 1pc</p>	<p>7</p>  <p>Screws 1/4" x50 2pcs</p>
<p>8</p>  <p>M4 x 20 mm Wood Screws 8pcs</p>	<p>9</p>  <p>Ø1/4" x 25 mm Hex-Head bolts 37pcs</p>	<p>10</p>  <p>Ø1/4" x 15 mm Canopy head though- 14pcs</p>
<p>11</p>  <p>Ø1/4" x 50 mm Hex-Head bolts 2pcs</p>	<p>12</p>  <p>Ø1/4" x 13 mm Horizontal-Hole bolts 28pcs</p>	<p>13</p>  <p>Ø12 x 110 mm Wood dowel 4pcs</p>
<p>14</p>  <p>Ø8 x 25 mm Wood dowel 22pcs</p>	<p>15</p>  <p>M6 x 15 mm Wood Screws 33pcs</p>	<p>16</p>  <p>Screws 1/4" x60 4pcs</p>
<p>17</p>  <p>Ø1/4" x 35 mm Hex-Head bolts 9pcs</p>		

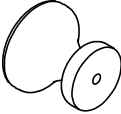
Hardware List

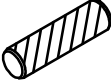
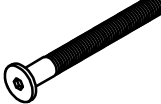
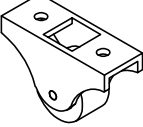
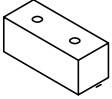
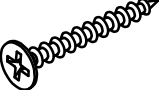
18  Wood Handle 3pcs	19  Ø1/6" x 25 mm 3pcs	20  Ø1/4" x 30 mm Hex-Head bolts 4pcs
21  Ø8 x 30 mm Wood dowel 2pcs	22  Ø1/4" x 70 mm Hex-Head bolts 4pcs	23  Wheels 4pcs
24  Stop Trundles - 2pcs	25  M3 x 12 mm Wood Screws 6pcs	

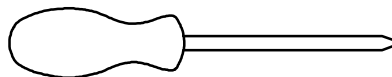

Assembly Tools Required (Not Included)

STEP 1: Following below illustration Assembly Bottom bed's Headboard.

Using hardware #1 and dowel #2 connect A1 and A2 legs with B1 Frame.

Look at detail view for more detail

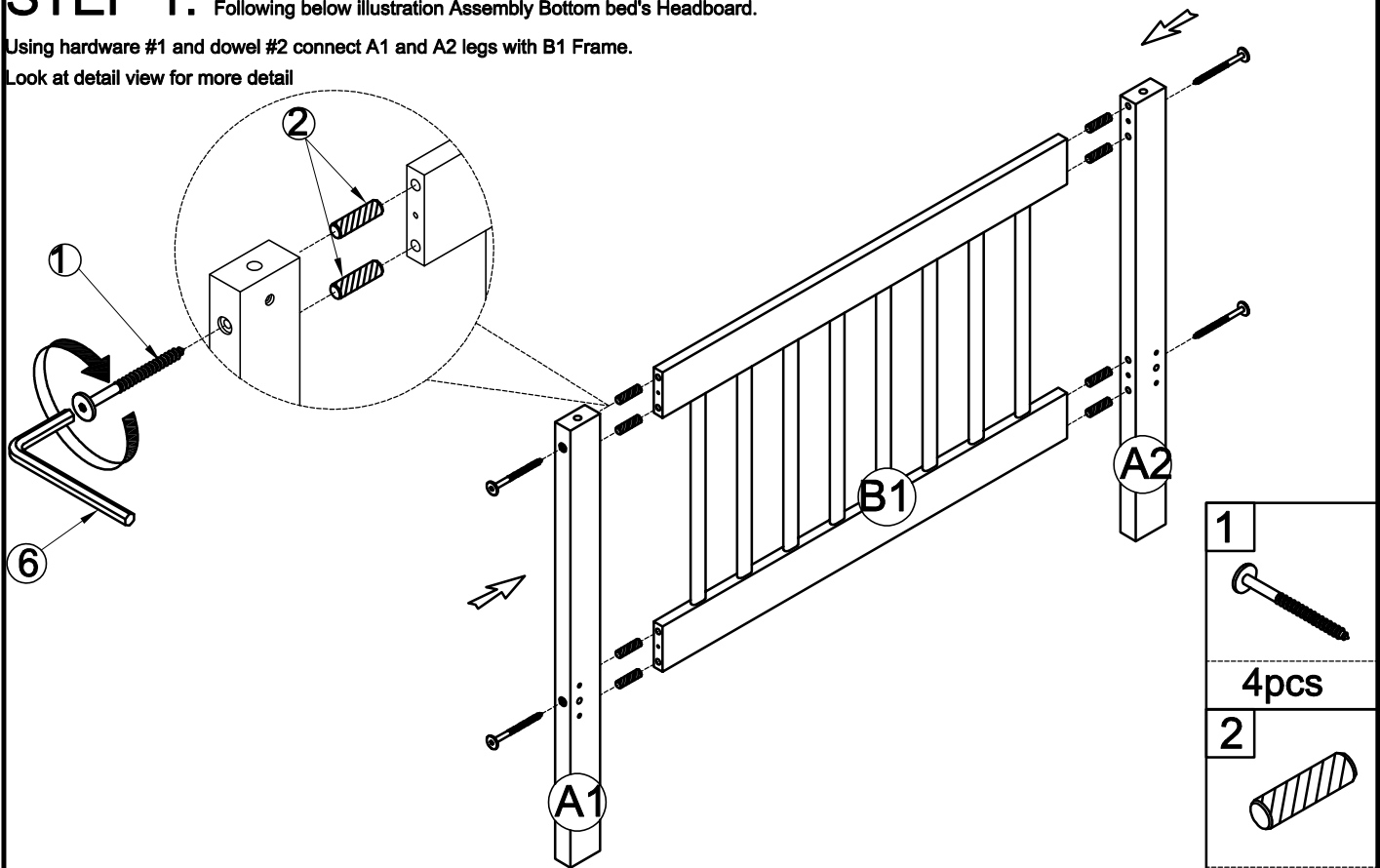



STEP 2: Following below illustration Assembly Bottom bed's Headboard.

Using hardware #3 connect Frame(completed on step 1) with B3 to complete LEFT side of Bottom Bed.

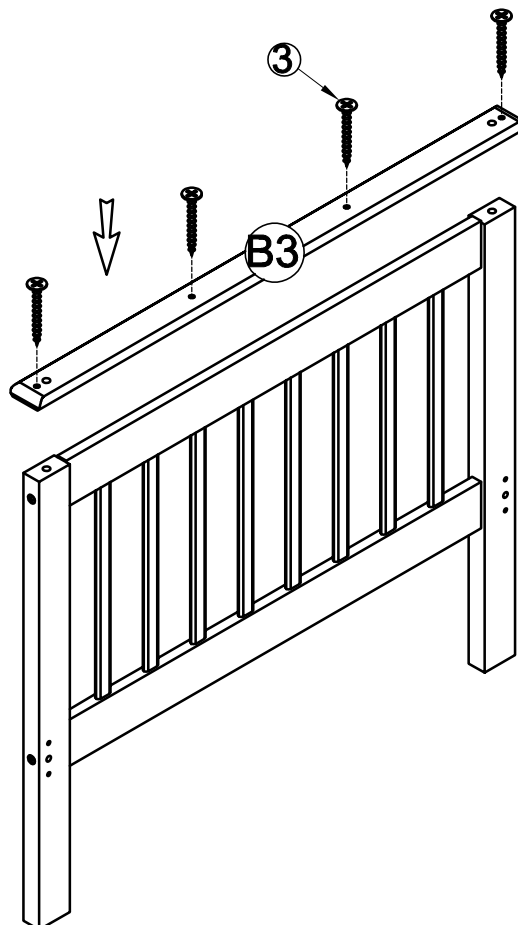
Look at detail view for more detail

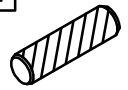





1	
	4pcs
2	
	8pcs
3	
	4pcs

STEP 3: Following below illustration Assembly Bottom bed's Footboard.

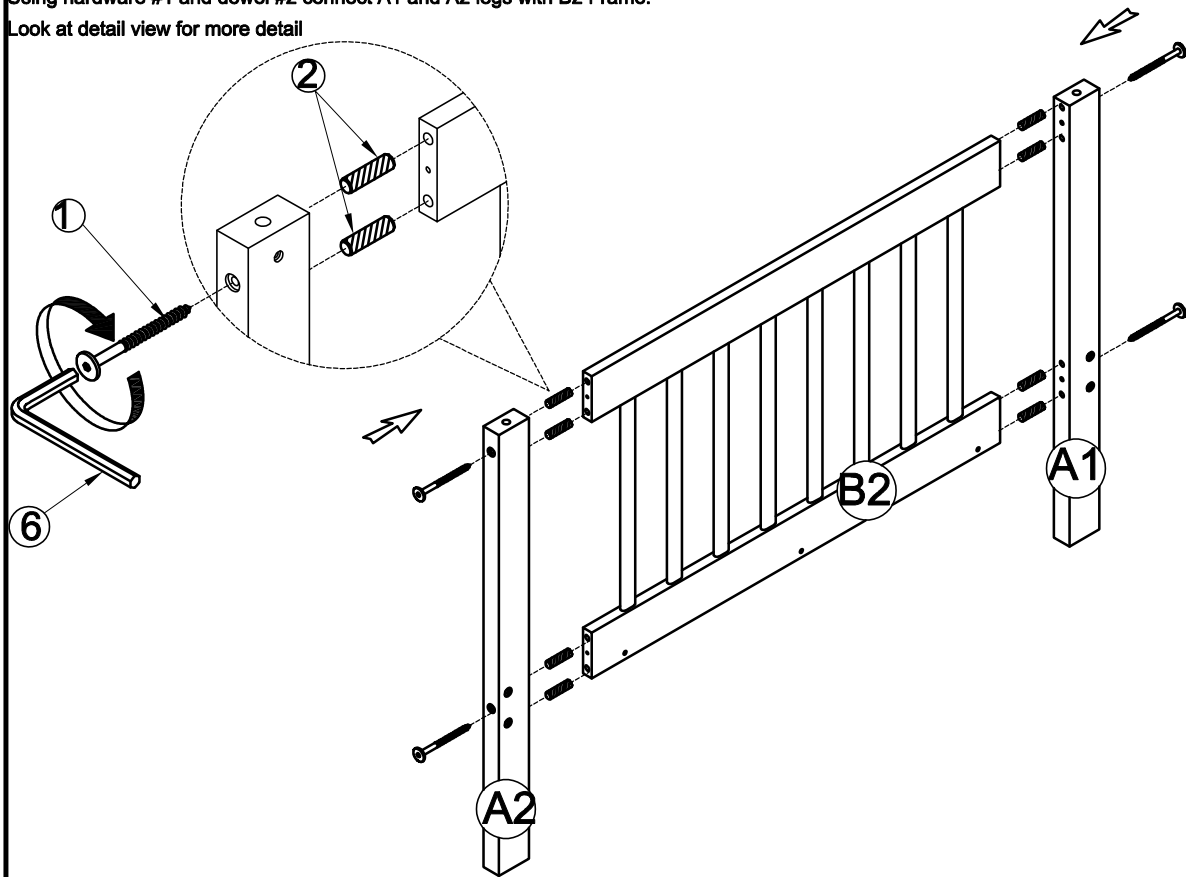
Using hardware #1 and dowel #2 connect A1 and A2 legs with B2 Frame.

Look at detail view for more detail

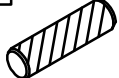

1	
	4pcs
2	
	8pcs
3	
	4pcs

STEP 4: Following below illustration Assembly Bottom bed's Headboard.

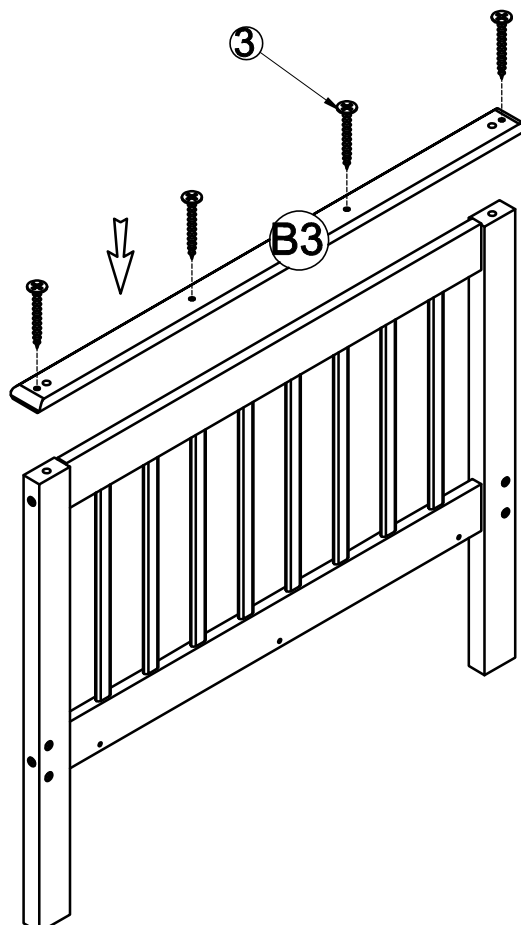

Using hardware #3 connect Frame(completed on step 3) with B3 to complete RIGHT side of Bottom Bed.

Look at detail view for more detail



STEP 5:

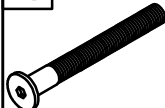

Following below illustration Using hardware #4,#12 and dowel #2 follow detail view to Assembly Bottom bed's Headboard(Completed on step 2) and Footboard(Completed on step 4) with siderail C5(x2).Look at detail view for more detail

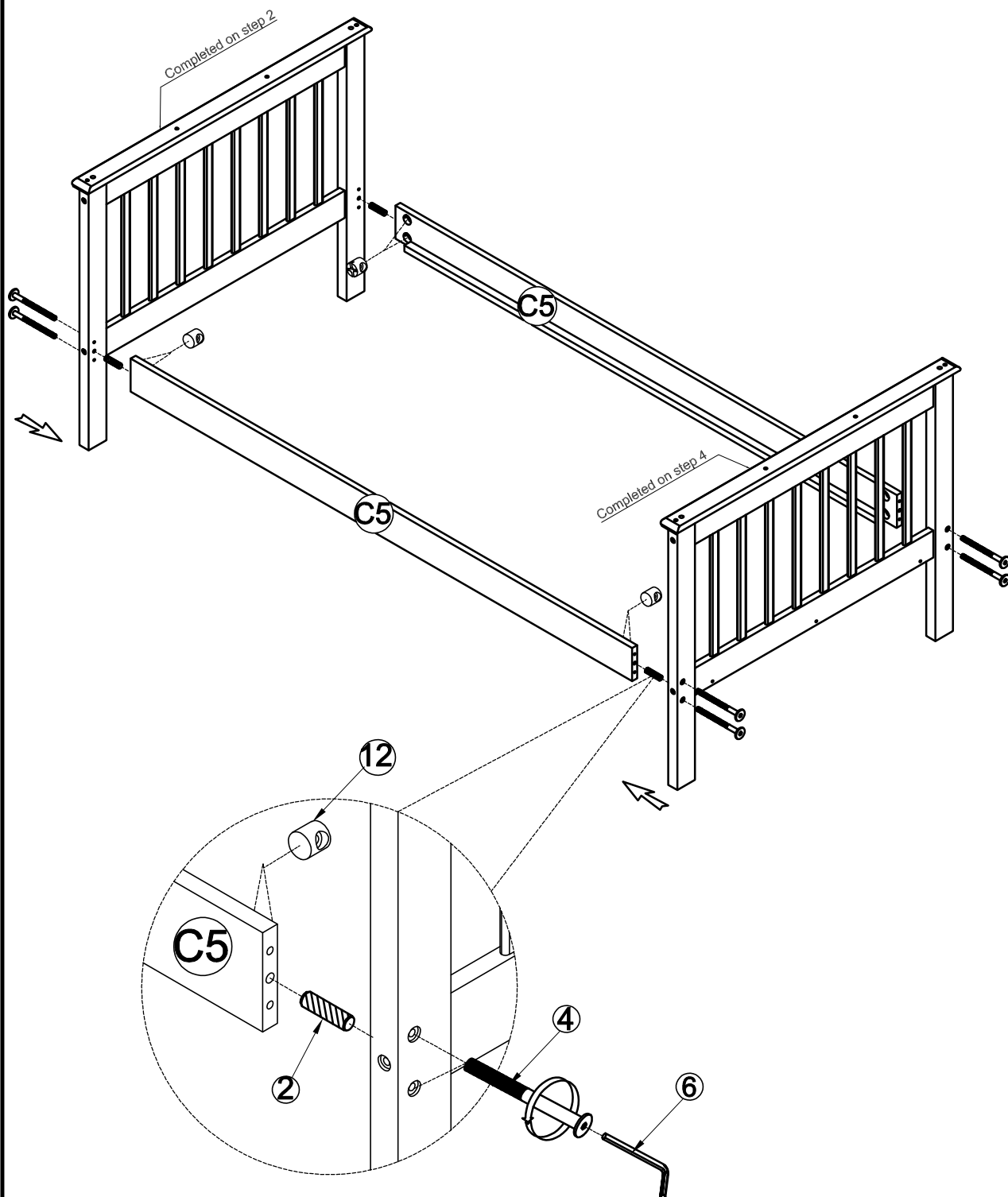
12	4	2
		
8pcs	8pcs	4pcs



STEP 6: Following below illustration:

- Screw 14 slats D with Side Rail C5 by using hardward #3.
- Screw 2 Stop Trundle on Siderail using hardward #3
- Look at detail view for more detail

24	3
	
2pcs	32pcs

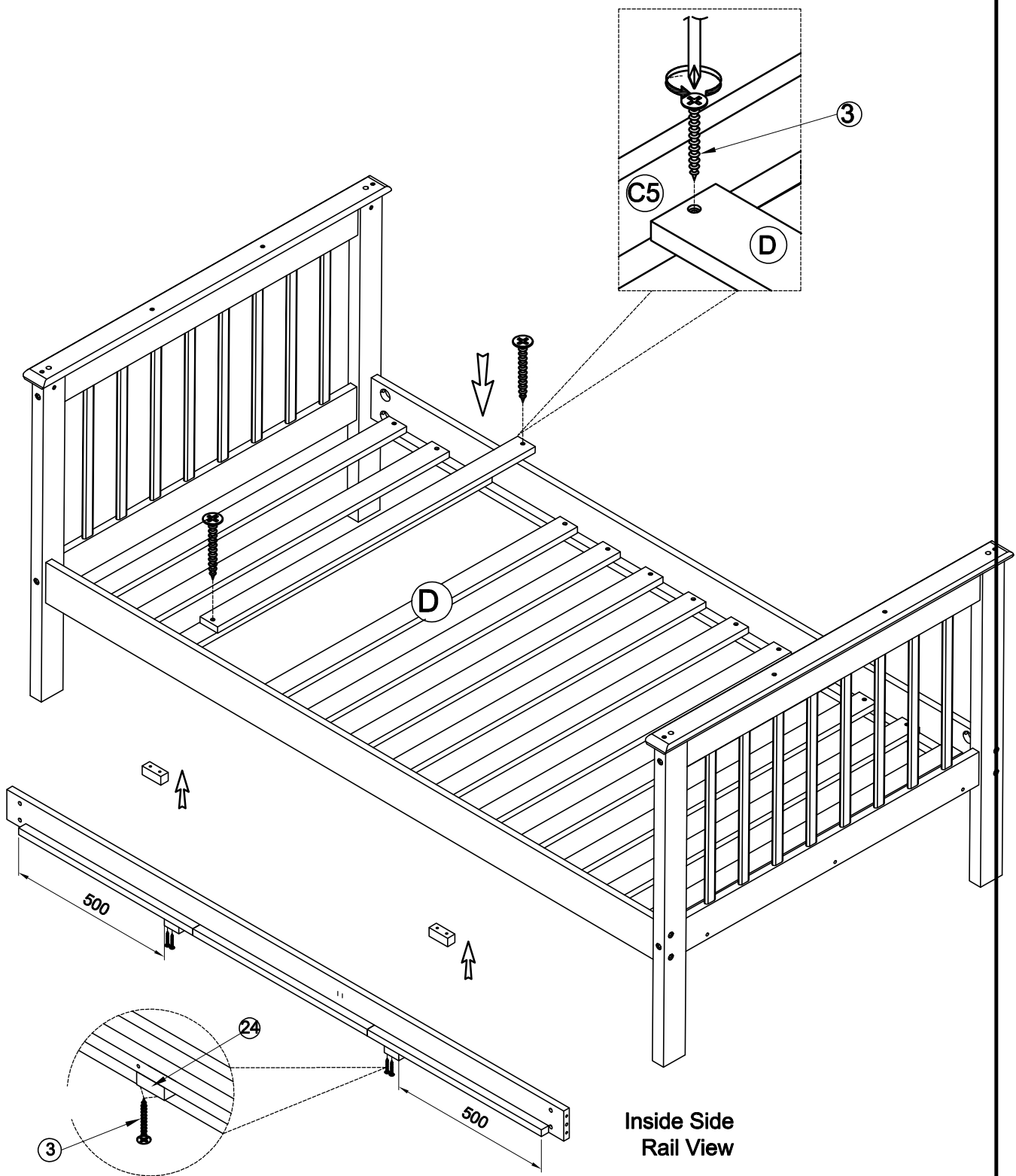

Inside Side Rail View

STEP 7: Following below illustration Assembly Upper bed's Headboard.

Using hardware #1 and dowel #2 connect A3 and A4 legs with B4 Frame.

Look at detail view for more detail

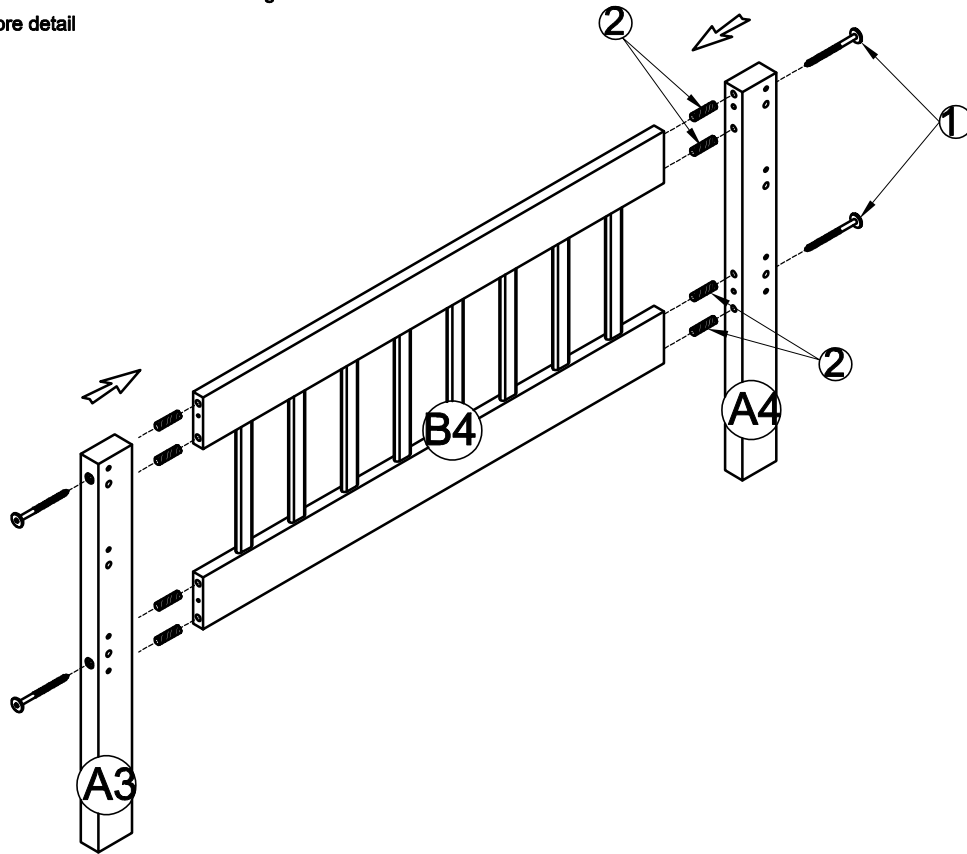

1



4pcs

2

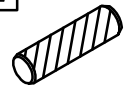

8pcs

STEP 8: Following below illustration Assembly Upper bed's Headboard.

Using hardware #3 connect Frame (completed on step 7) with B5 Woodbar

Look at detail view for more detail

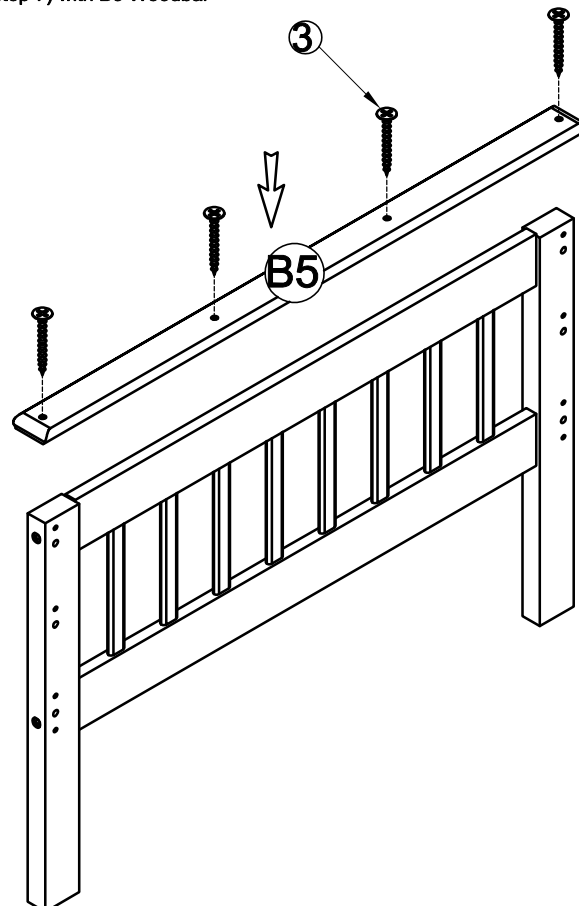

3



4pcs

STEP 9: Following below illustration Assembly Upper bed's Footboard.

Using hardware #9,#10 connect B7 Frame with B6 Woodbar
Look at detail view for more detail

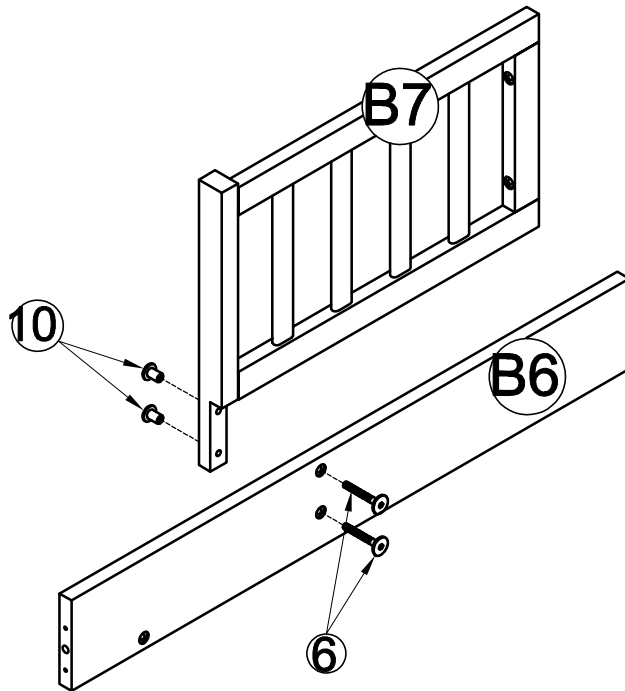

9



2pcs

10



2pcs

STEP 10: Following below illustration Assembly Upper bed's Footboard.

Using hardware #1,#11 and dowel #2 connect Frame(completed on step 9) with Legs A5,A6
Look at detail view for more detail

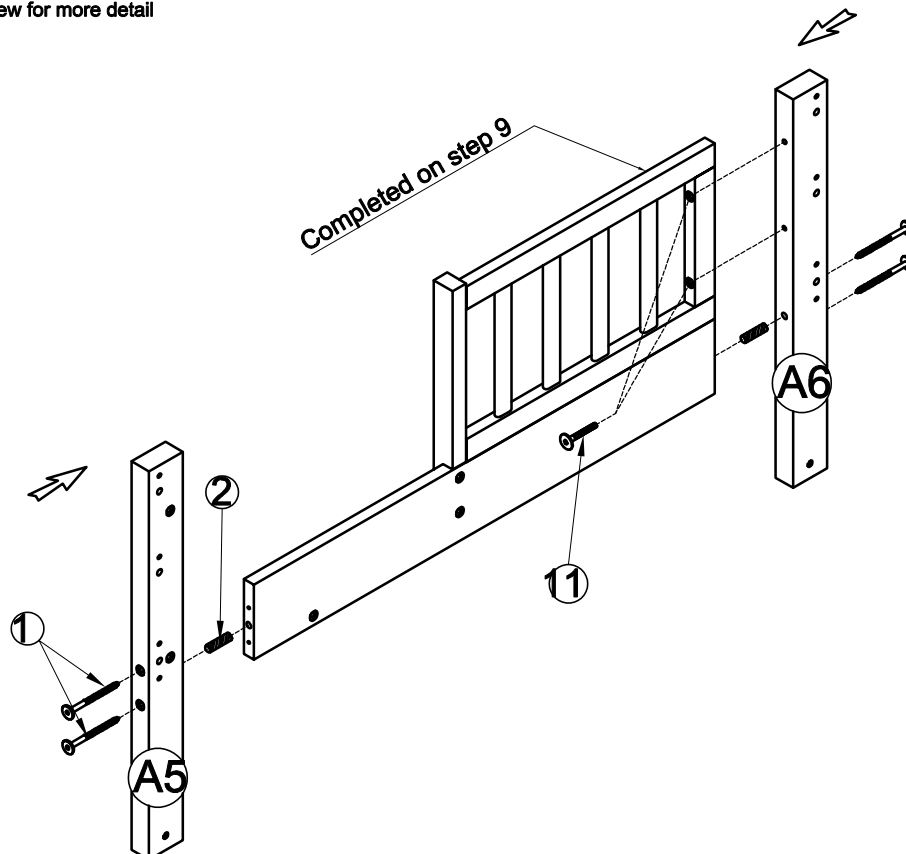

1



4pcs

2

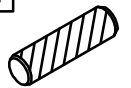

2pcs

11





2pcs

STEP 11: Following below illustration Assembly Upper bed's Footboard.



Using hardware #9,#10 connect B7 Frame with B6 Woodbar

Using hardware #7 connect Frame with Bracket #8.

Look at detail view for more detail

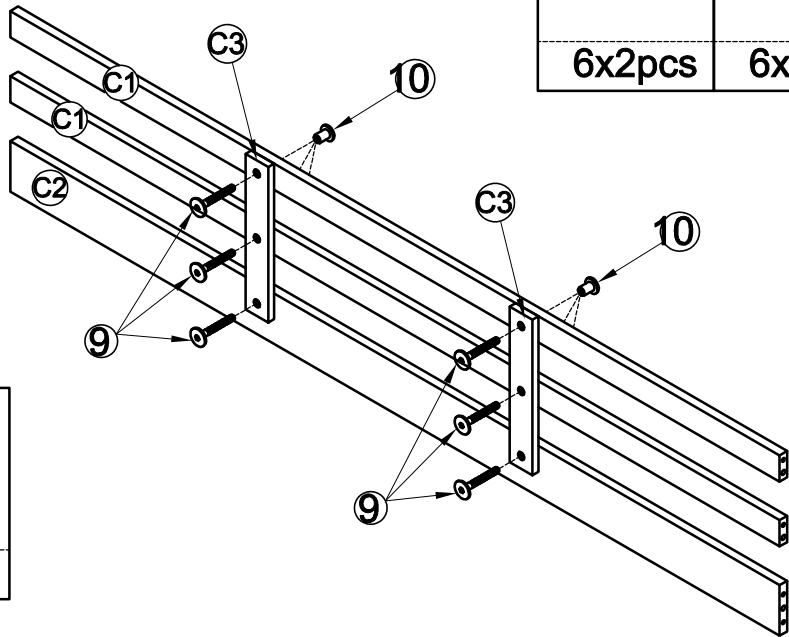
10	9
	
6x2pcs	6x2pcs

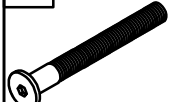

12	4	2
		
16pcs	16pcs	12pcs

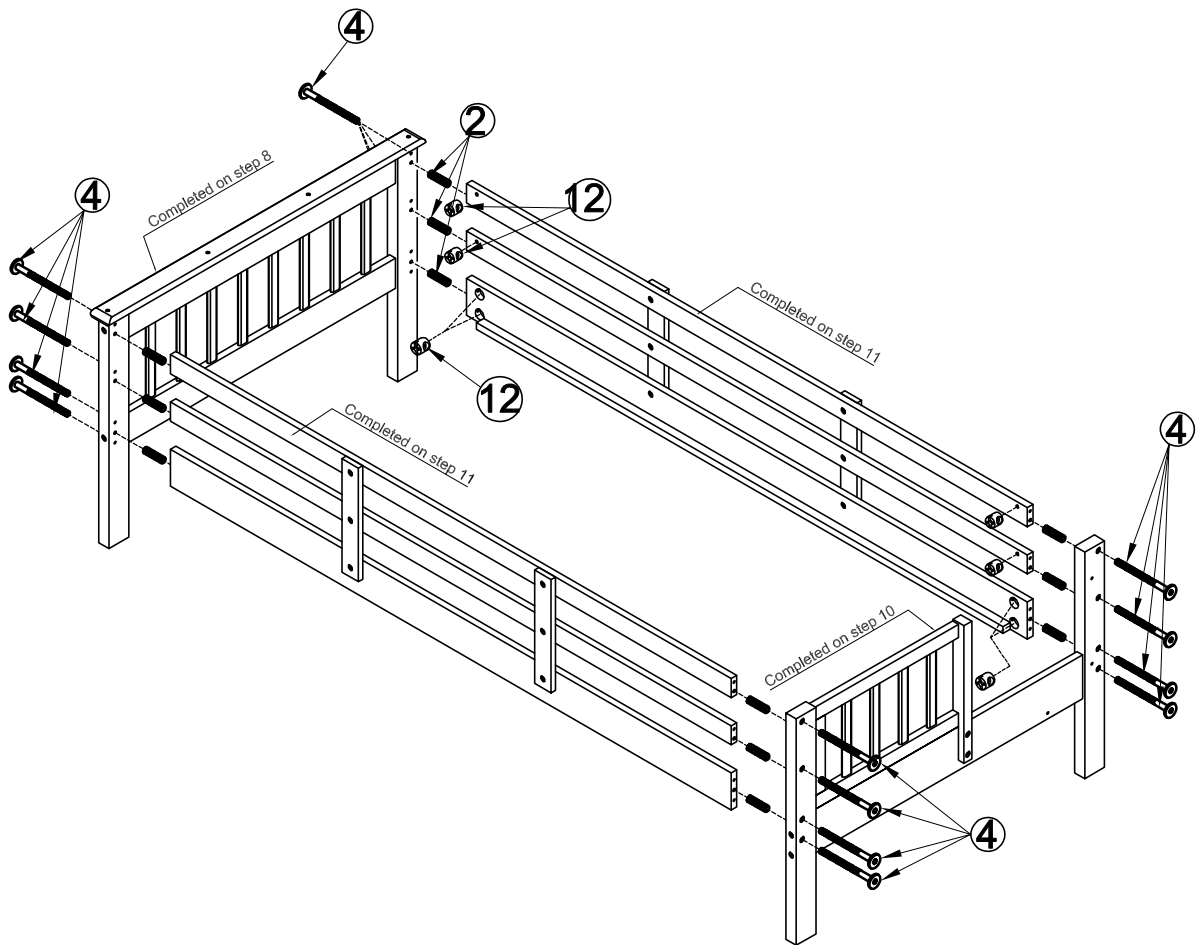

STEP 12: Following below illustration Using hardware #4,#12 and dowel #2

follow detail view to Assembly Upper bed's Headboard(Completed on step 8) and

Footboard(Completed on step 10) with Frame (Completed on step 11).

Look at detail view for more detail

STEP 13: Following below illustration:

-Screw 14 slats D and with Side Rail C2 by using hardward #3.

-Look at detail view for more detail

3



28pcs

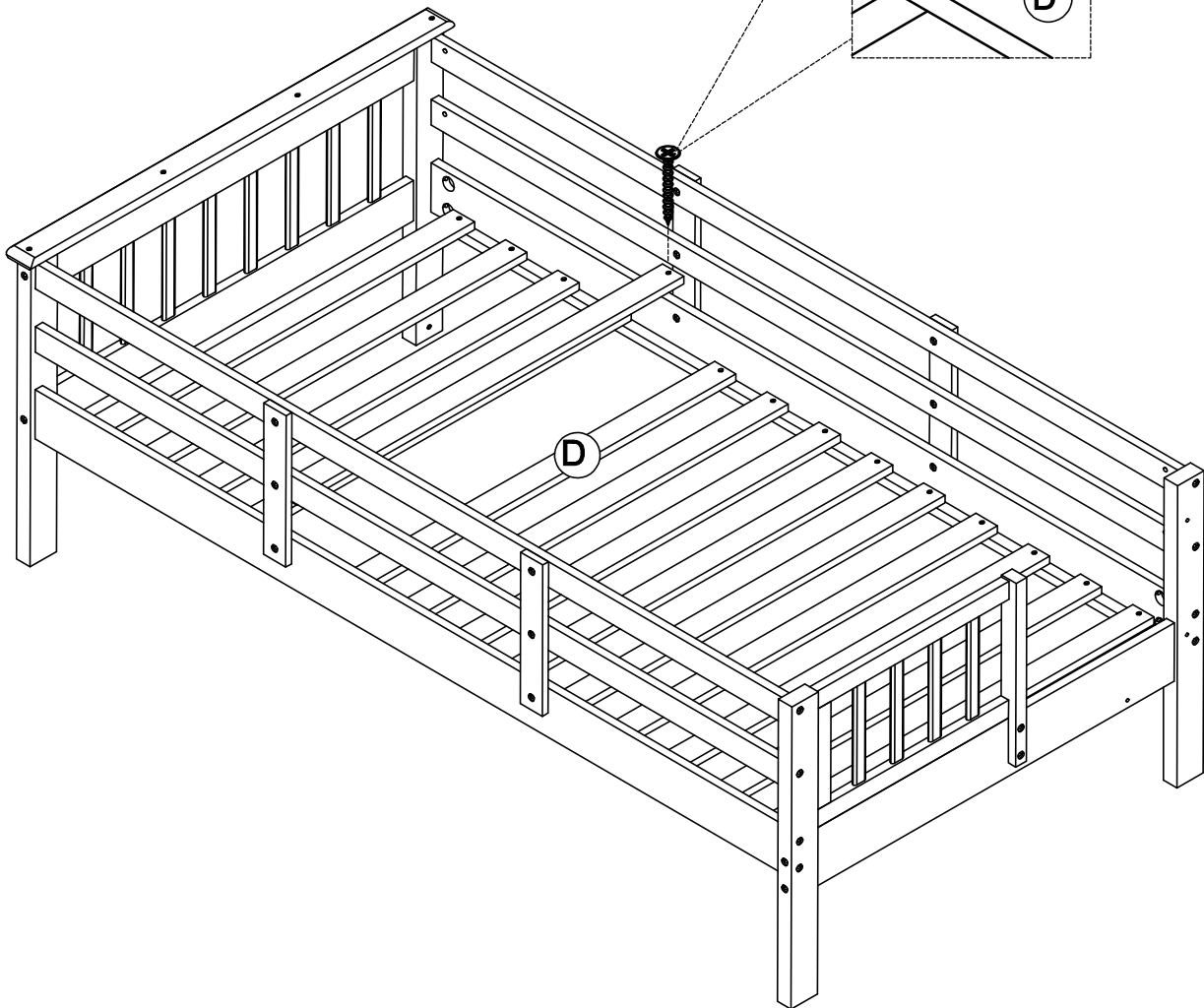
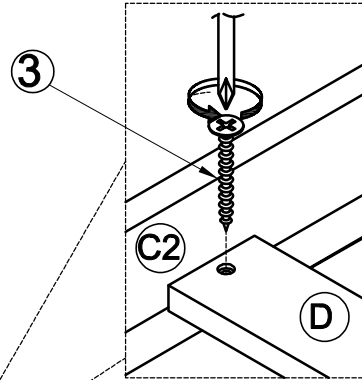

STEP 14:

Following below illustration. Lay the Upper Bed (Completed on step 13) on Bottom Bed (Completed on step 6). Using the Dowel #13 to connect head of Bottom Bed legs with end of Upper Bed legs.

13

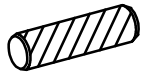

4(pcs)

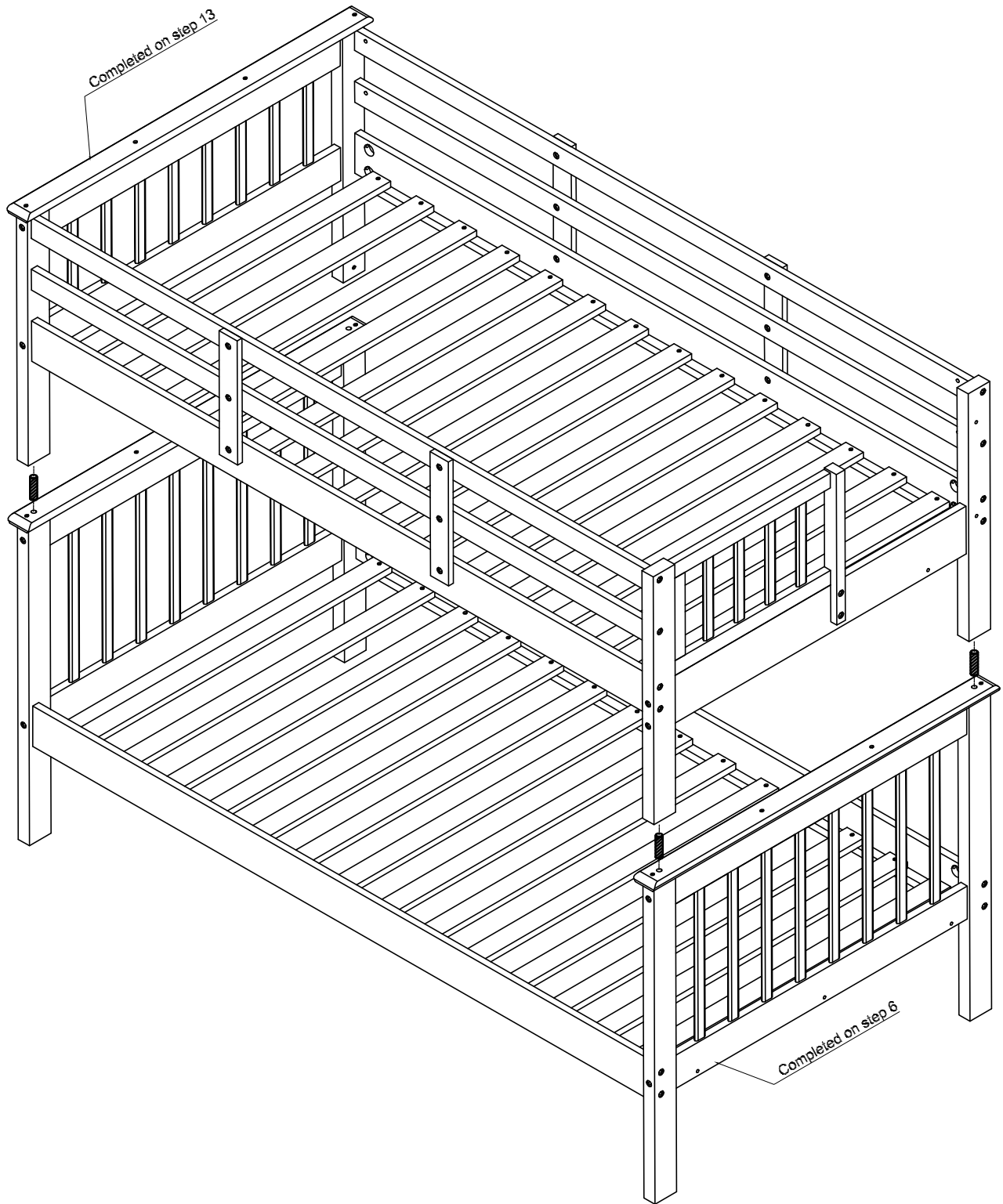

STEP 15-1:ASSEMBLY STAIRCASE

Using hardware #9 and dowel #14 connect Support Bar (E15) with E1,E10 panels

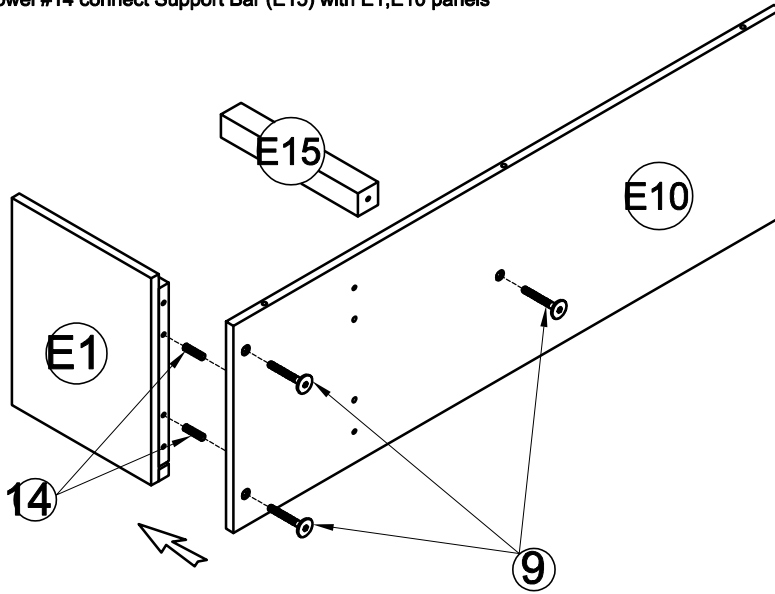

9



3pcs

14

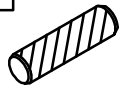

2pcs

STEP 15-2:ASSEMBLY STAIRCASE

Using hardware #9 and dowel #14 connect Frame(completed on step15-1) with E2 panel

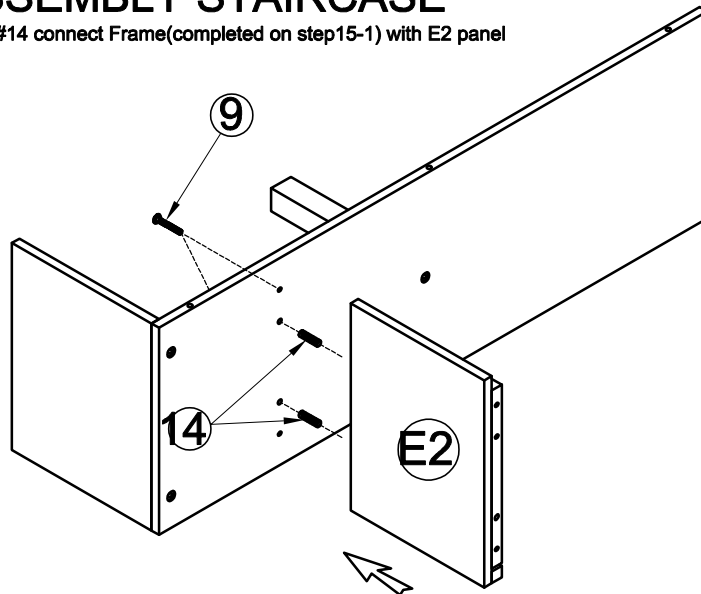

9



2pcs

14

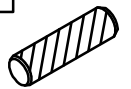

2pcs

STEP 15-3:ASSEMBLY STAIRCASE

Using hardware #9 and dowel #14 connect Frame(completed on step15-2) with E9 panel

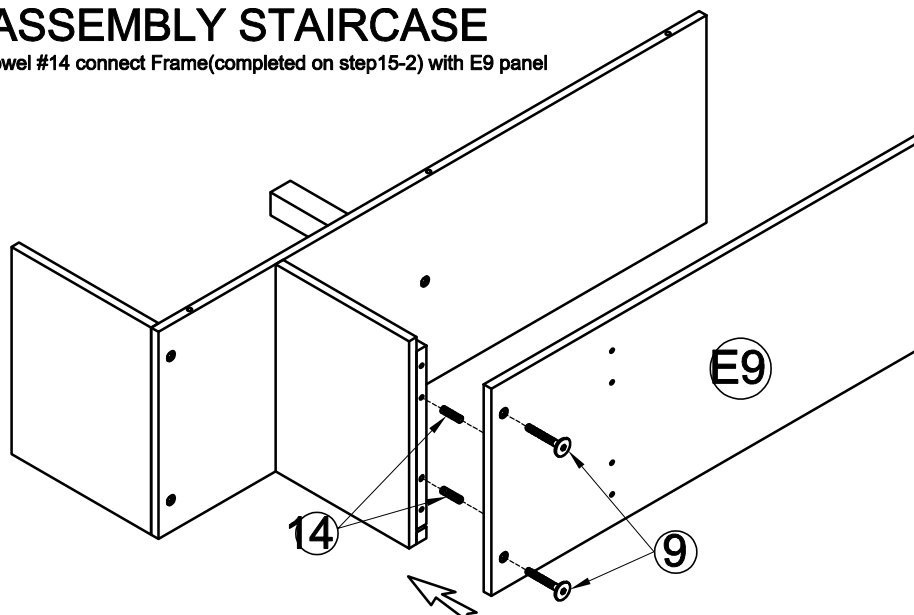

9



2pcs

14

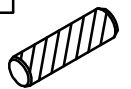

2pcs

STEP 15-4:ASSEMBLY STAIRCASE

Using hardware #9 and dowel #14 connect Frame(completed on step15-3) with E2 panel

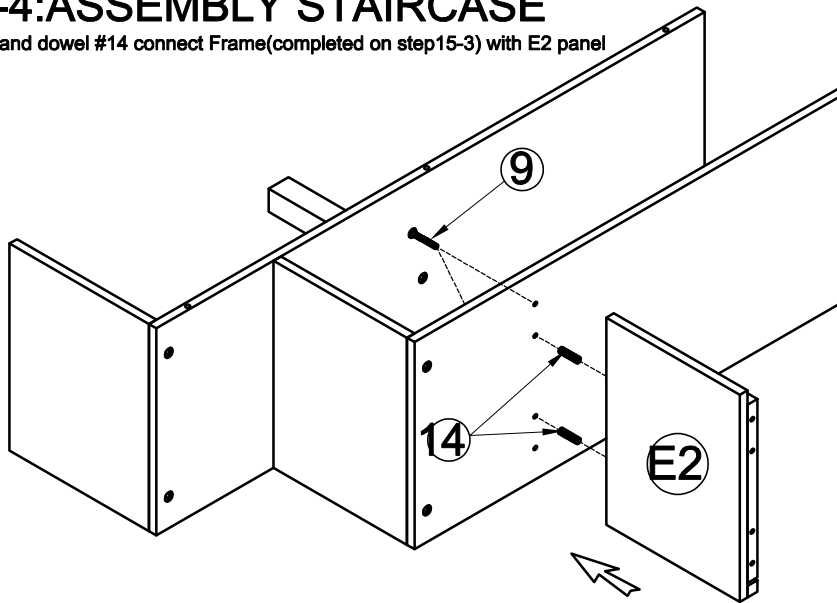

9	
	2pcs
14	
	2pcs

STEP 15-5:ASSEMBLY STAIRCASE

Using hardware #9 and dowel #14 connect Frame(completed on step15-4) with E8 panel

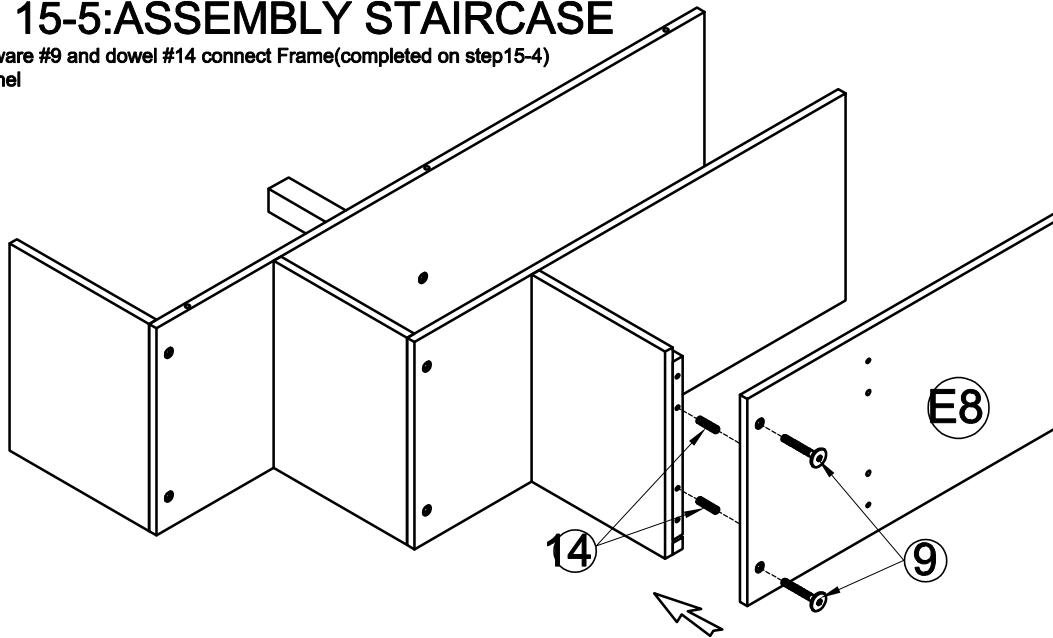

9	
	2pcs
14	
	2pcs

STEP 15-6:ASSEMBLY STAIRCASE

Using hardware #9 and dowel #14 connect Frame(completed on step15-5) with E3 panel

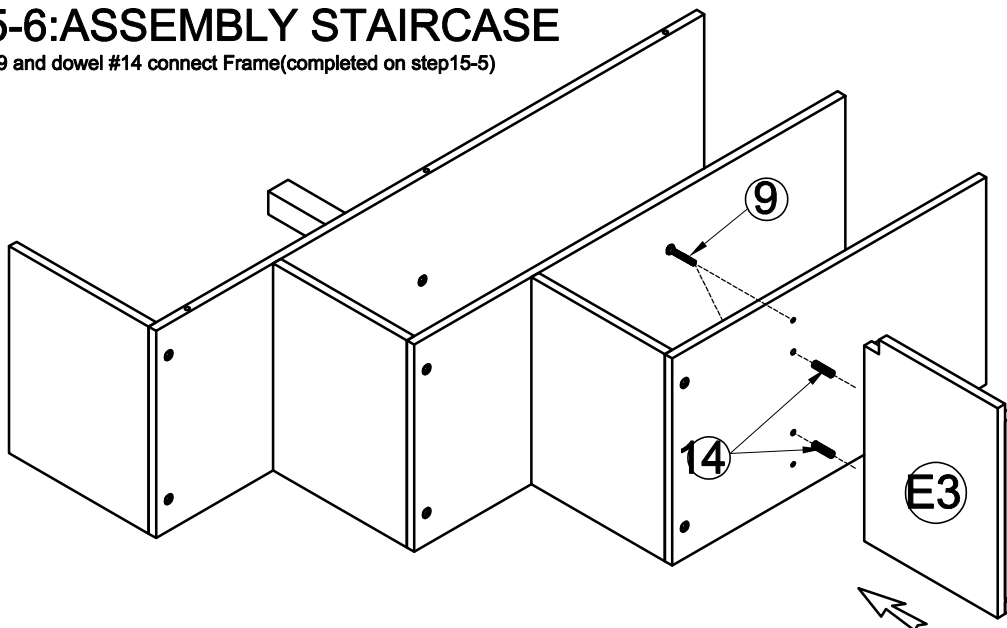

9	
	2pcs
14	
	2pcs

STEP 15-7:ASSEMBLY STAIRCASE

Using hardware #9 and dowel #14 connect Frame(completed on step15-6)
with E12 Frame

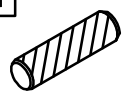
9	14
	
6pcs	6pcs

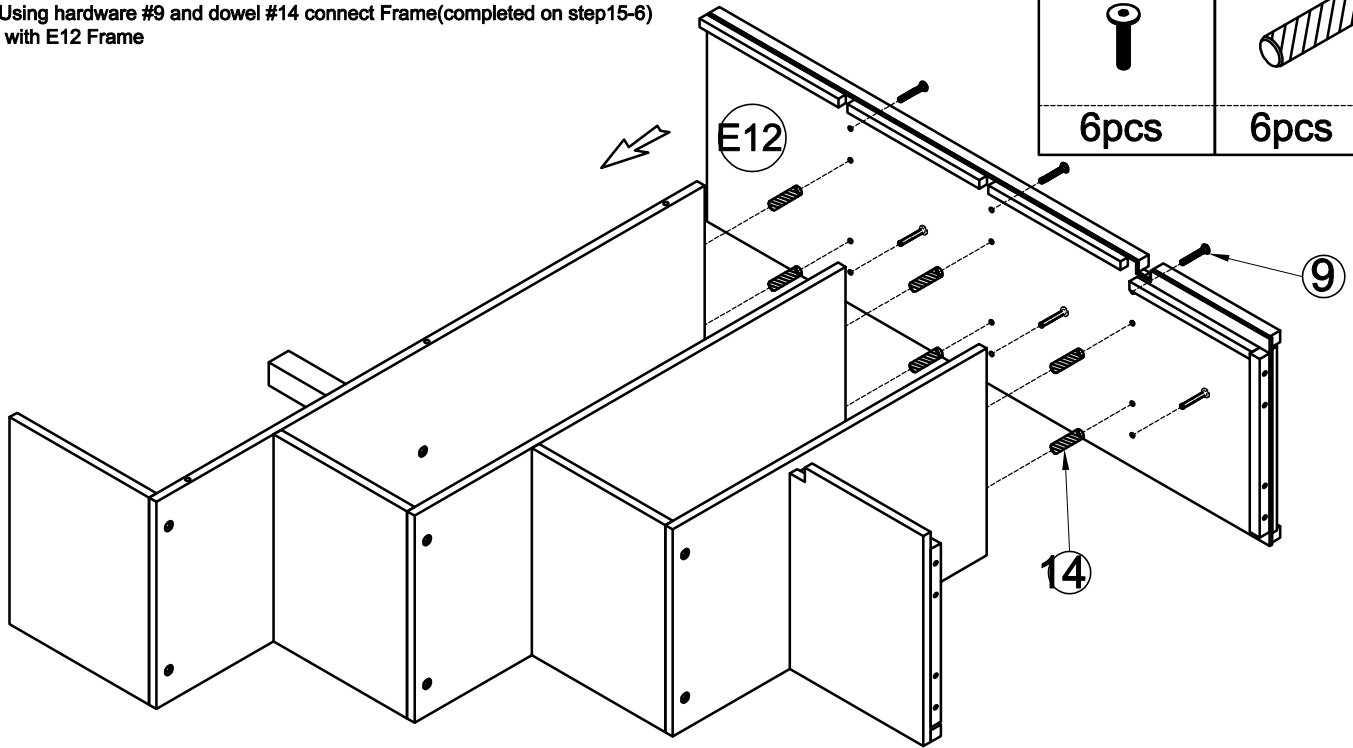

STEP 15-8:ASSEMBLY STAIRCASE

Using hardware #9 and dowel #14 connect Frame(completed on step15-7)
with E7 Panel

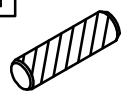
9	14
	
4pcs	4pcs

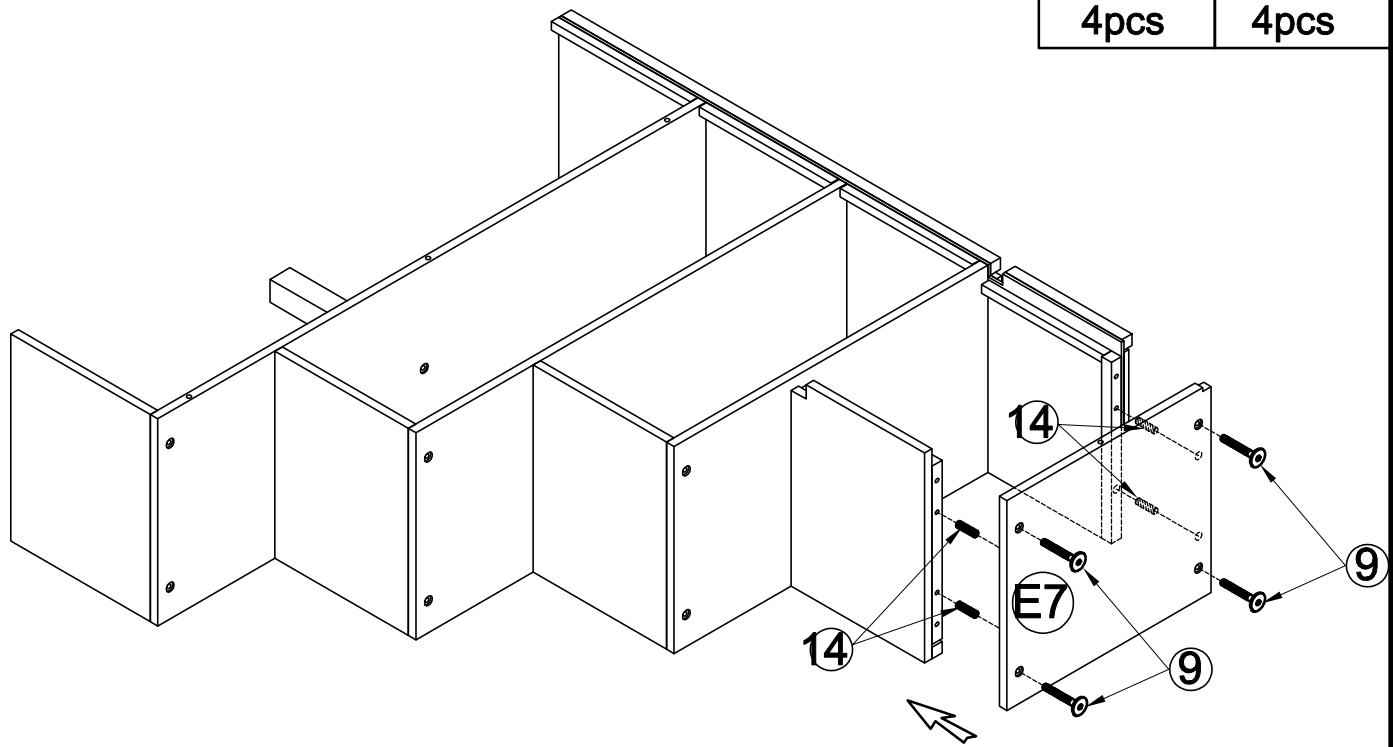

STEP 15-9:ASSEMBLY STAIRCASE

Using hardware #15 connect Frame(completed on step15-8) with E4,E5,E6 Panels

15



33pcs

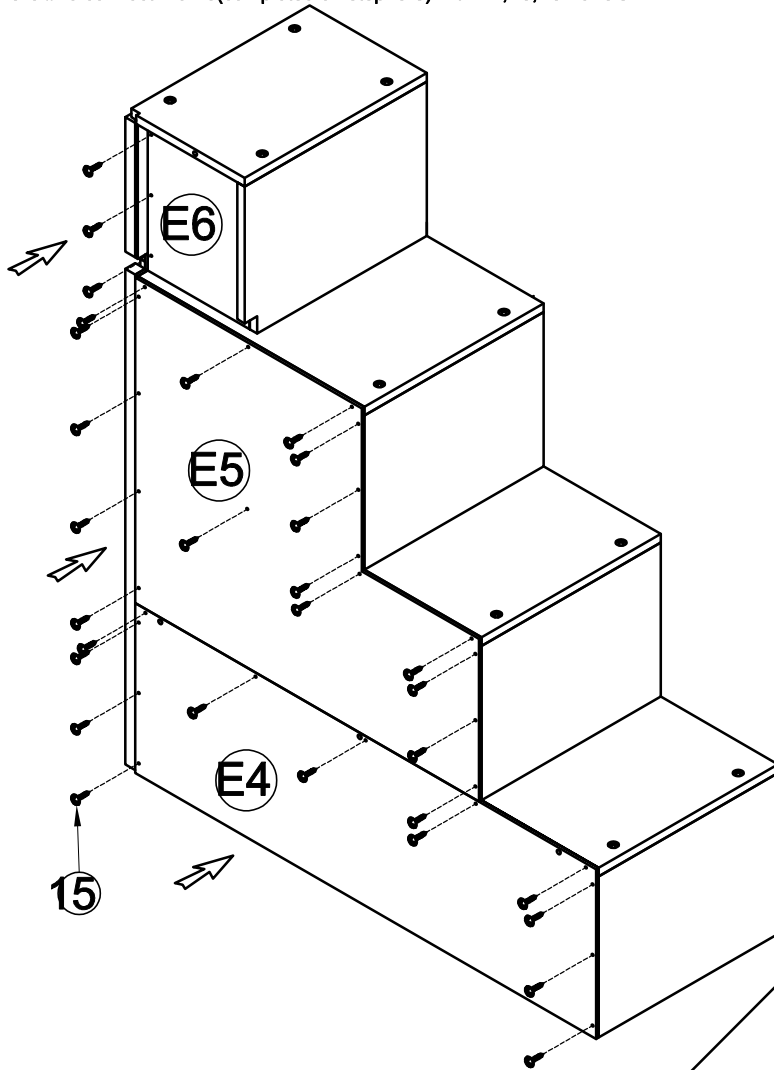

STEP 15-10:ASSEMBLY STAIRCASE

Using hardware #16 connect E13 Frame with E14 Frame

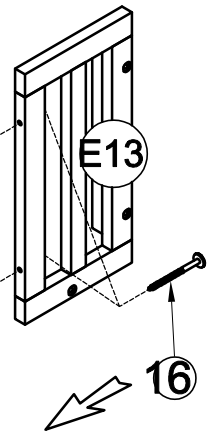

16



2pcs

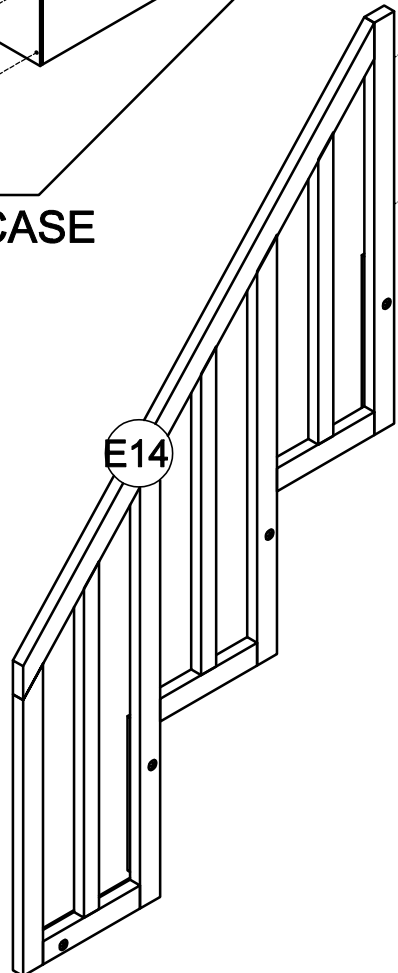

STEP 15-11:ASSEMBLY STAIRCASE

Using hardware #7,#17 connect Frame(completed on step15-9) with Frame(completed on step15-10) and E11 Frame

17



5pcs

7



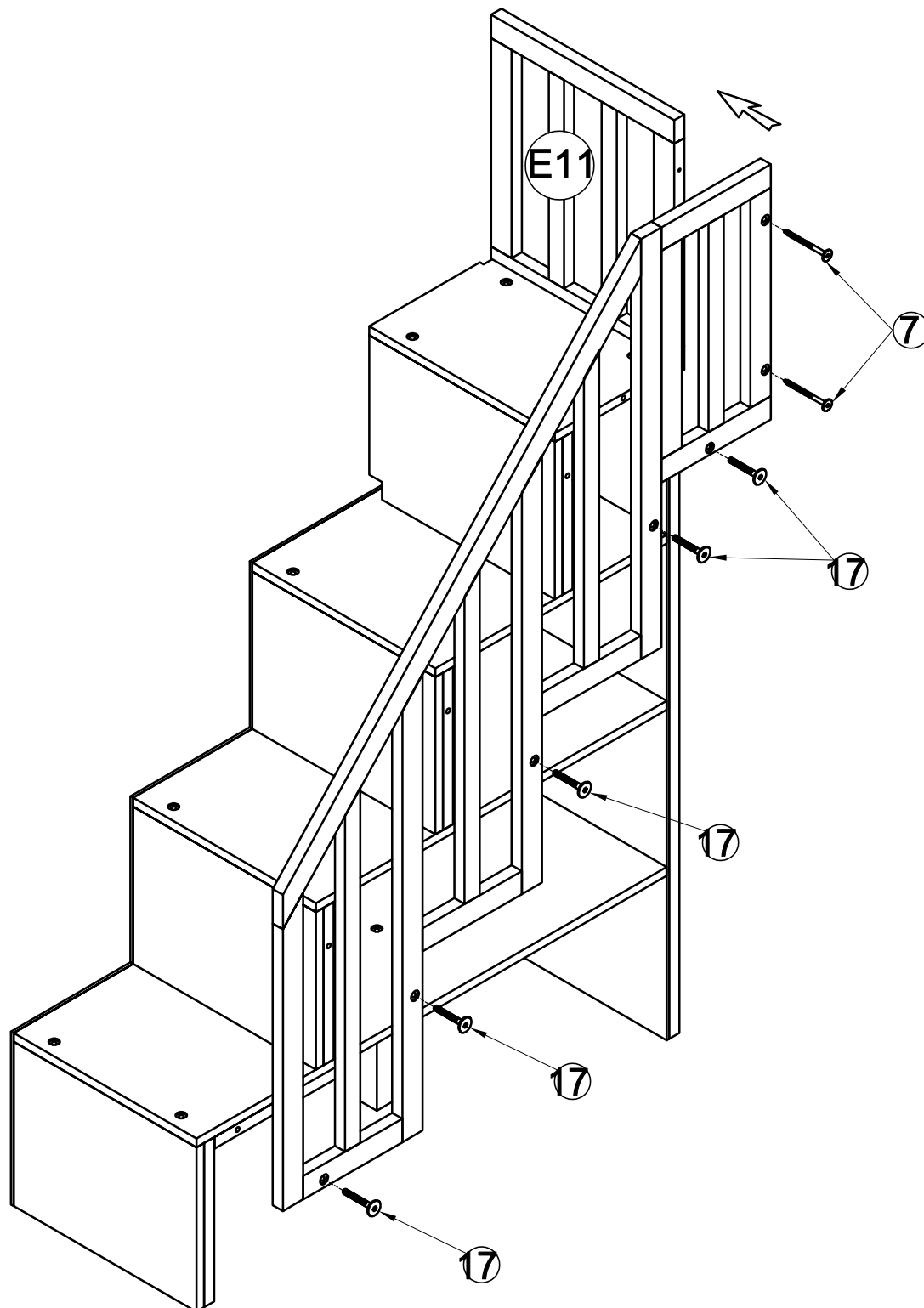

2pcs



STEP 16

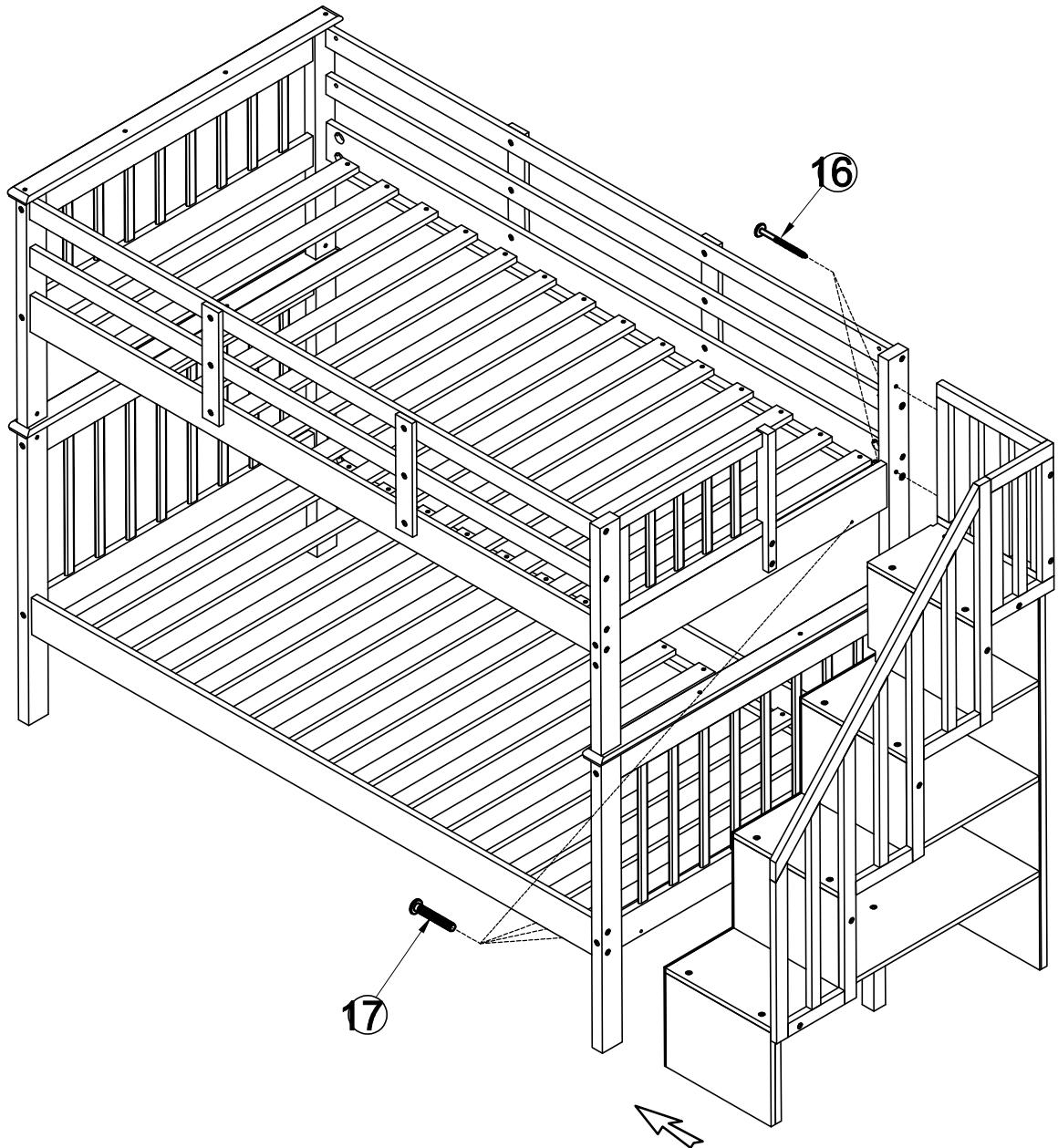

Align and fix the staircase and the bunk beds, Using #16,#17 connect the staircase with bunk beds

17	16
	
4pcs	2pcs



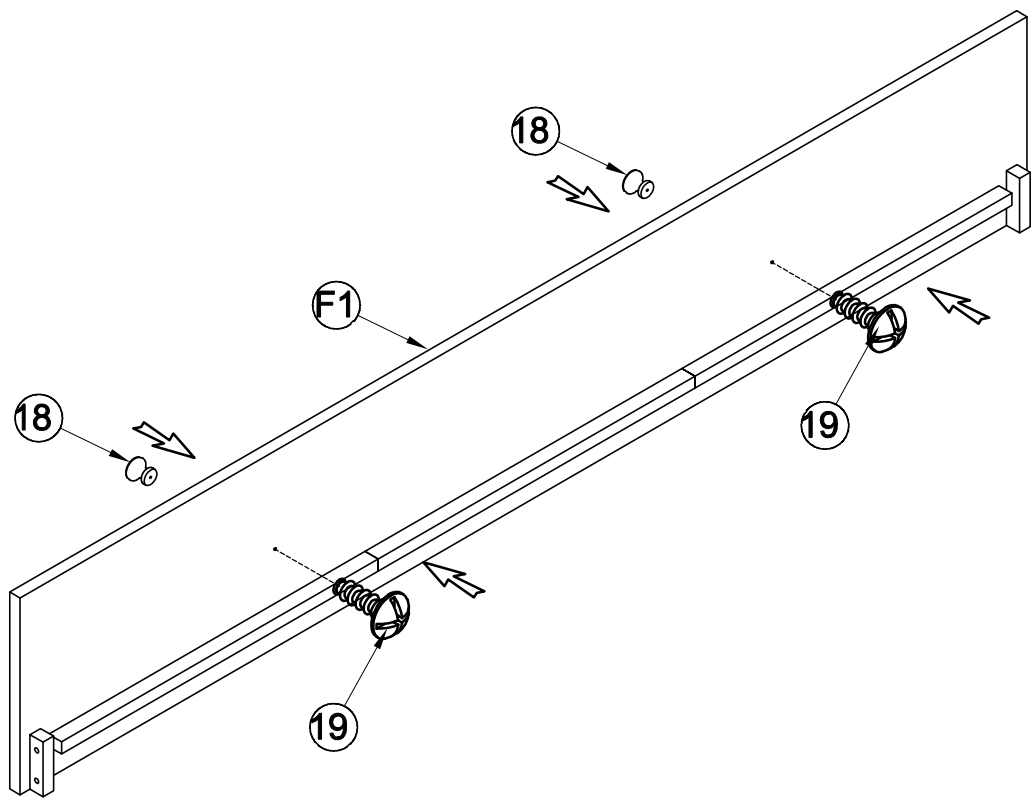



STEP 17-1: Assembly Wood Handle With Front Trundle F1 Using HW #19

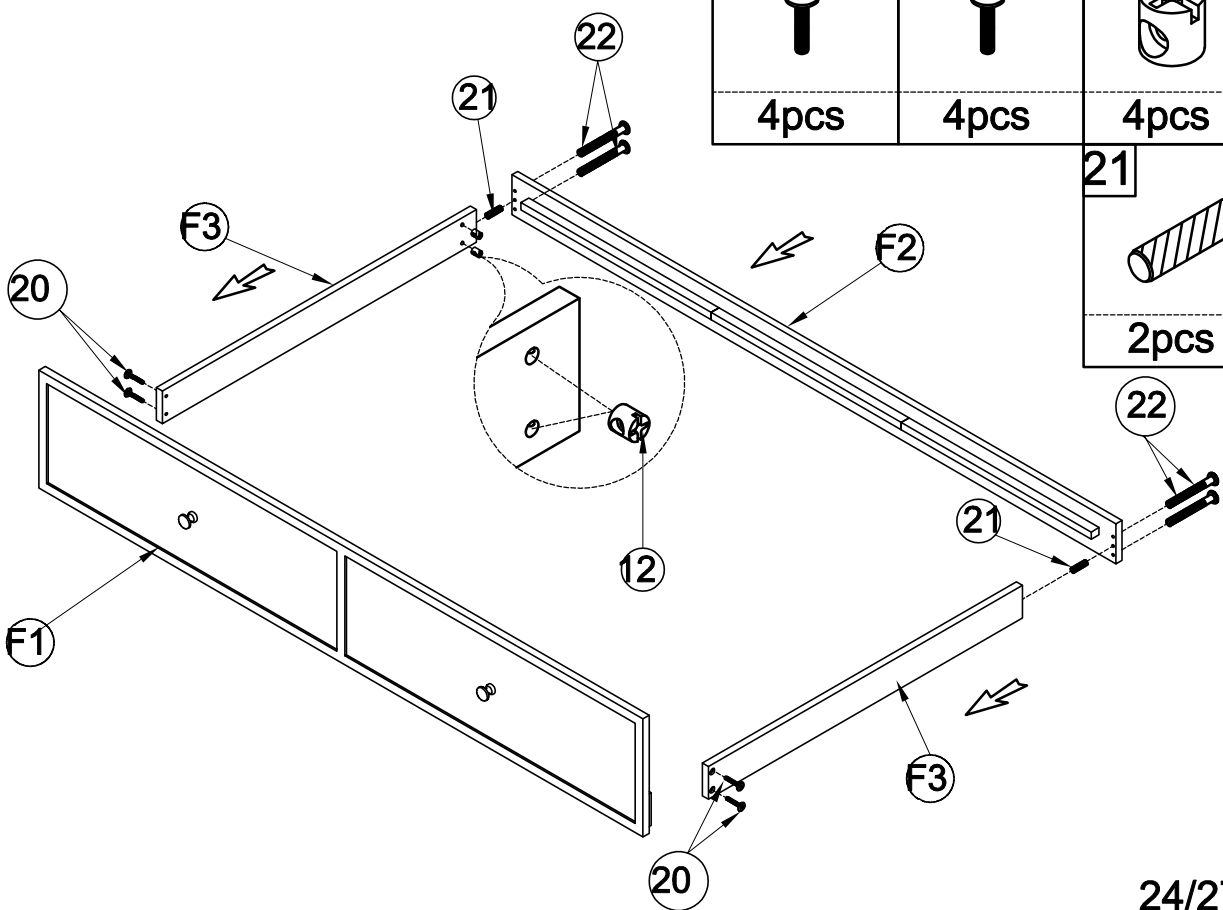

- | | |
|----|---|
| 18 |  |
| | 2pcs |
| 19 |  |
| | 2pcs |

STEP 17-2:

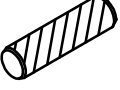

- | | | |
|----|---|------|
| 22 |  | 4pcs |
| 20 |  | 4pcs |
| 12 |  | 4pcs |
| 21 |  | 2pcs |

STEP 17-3:

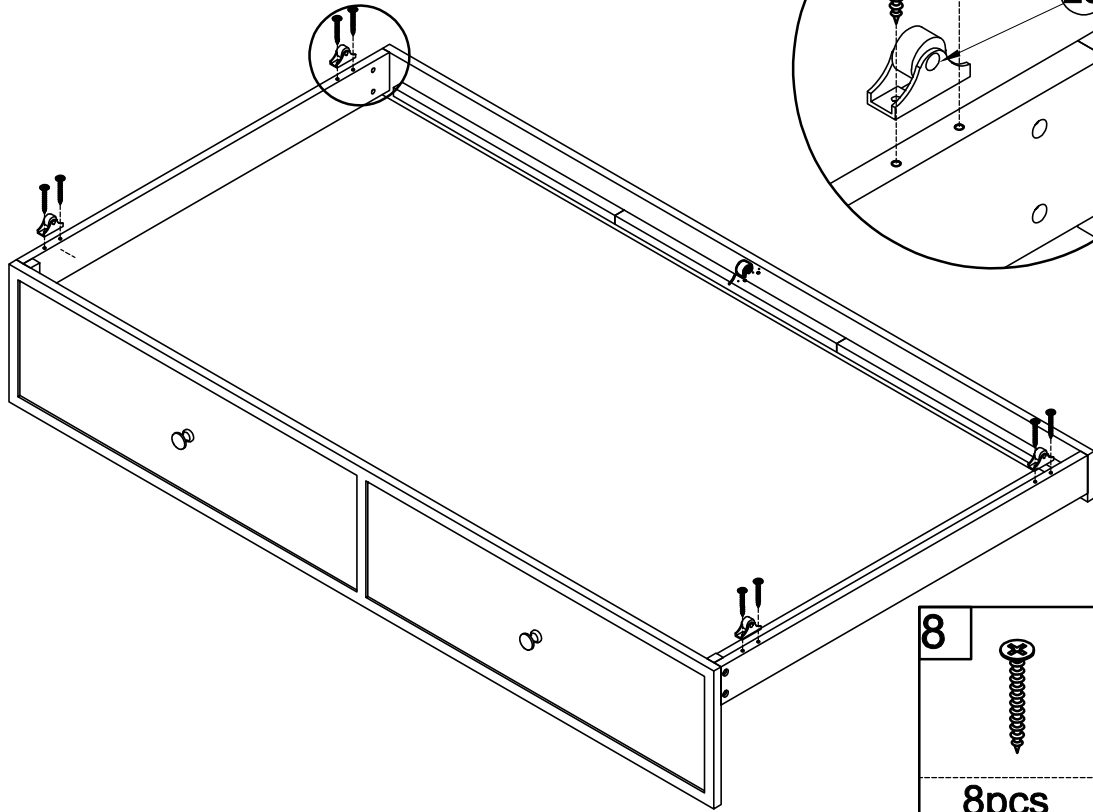

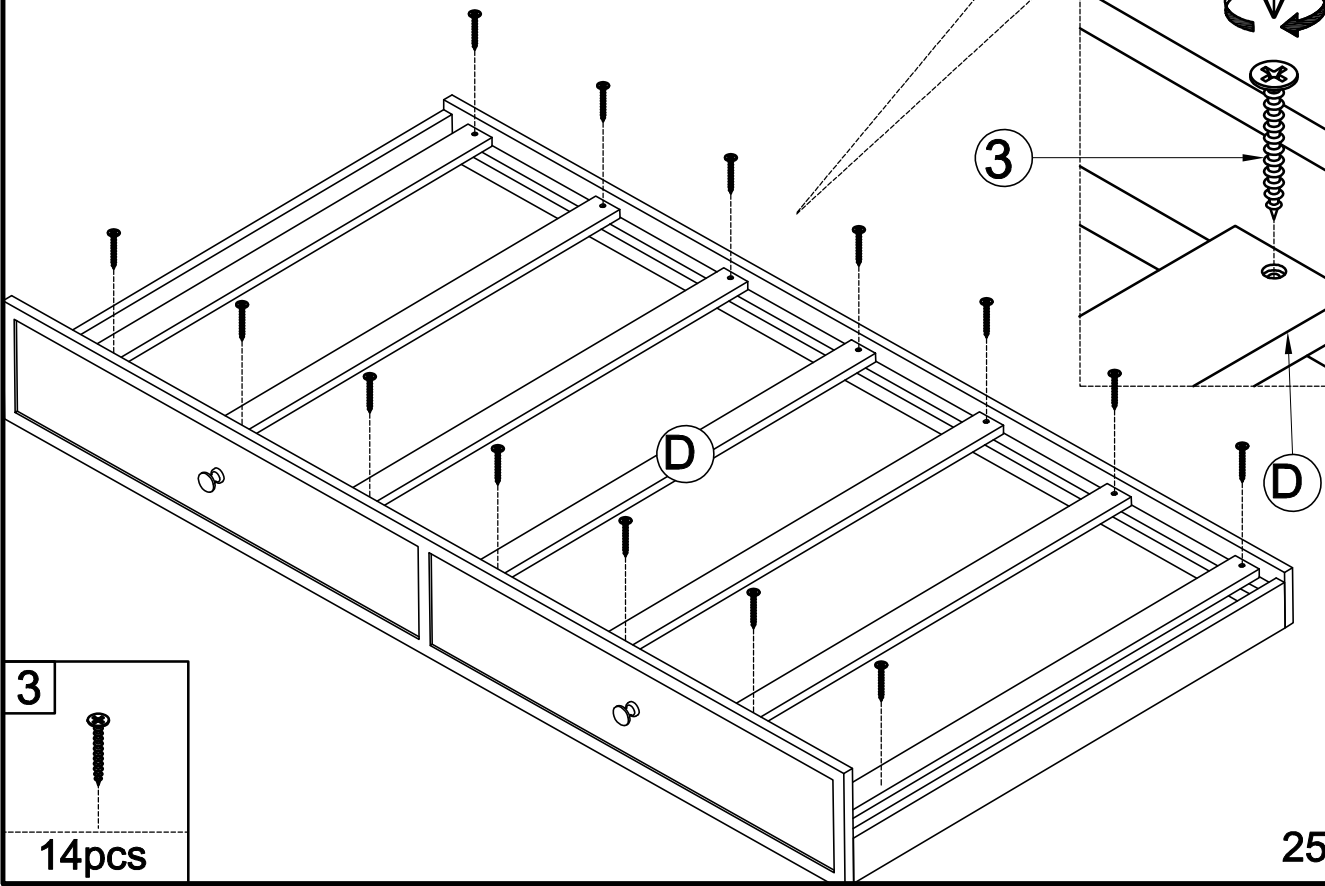

STEP 17-4:



STEP 18: Following below illustration:

- Screw 1 Handle Wood #18 With Door (T) by hardward #19
- Screw Door T with Bed using hardward #25.
- Look at detail view for more detail

18	25	19
		
1pc	6pcs	1pc

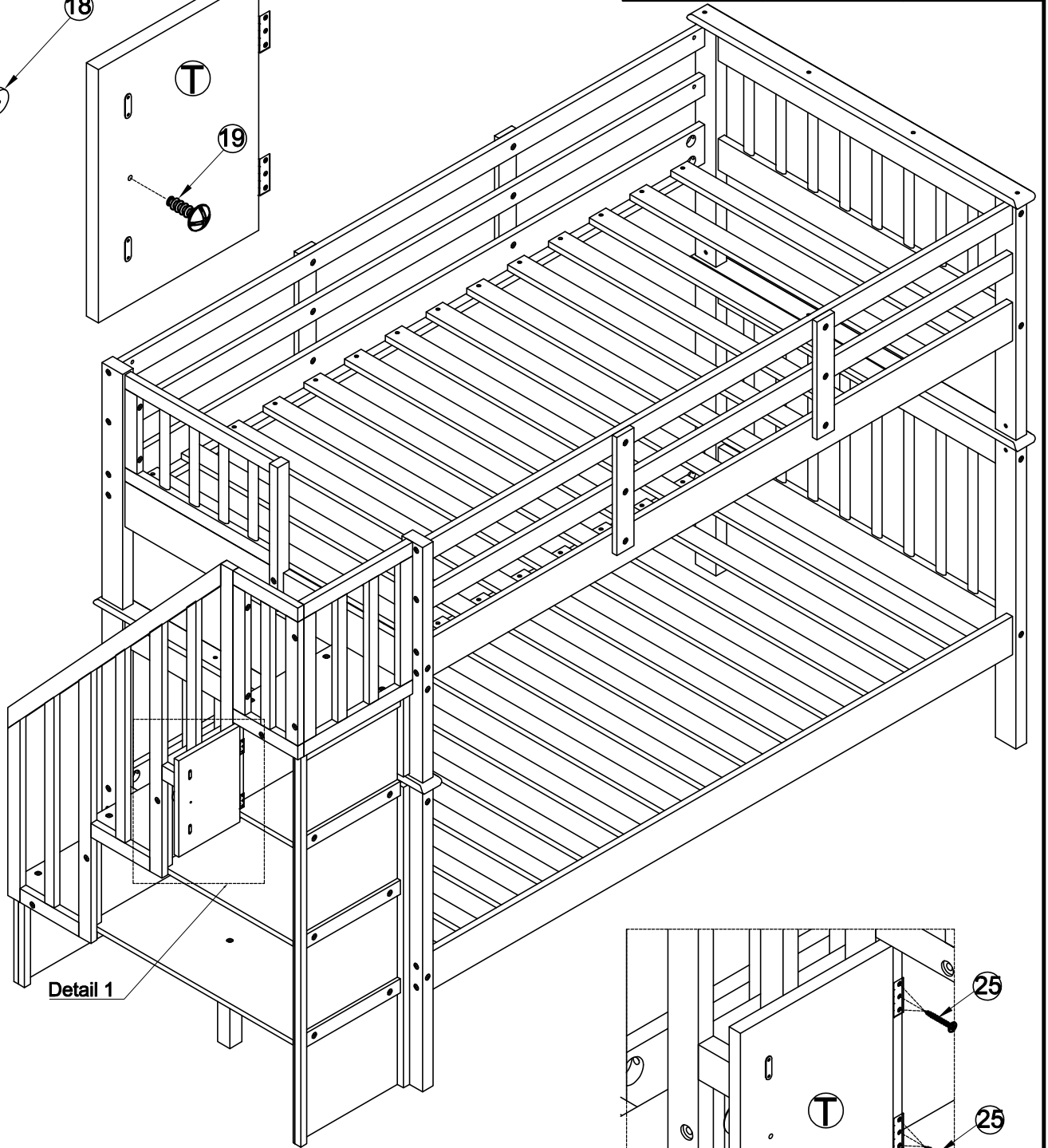
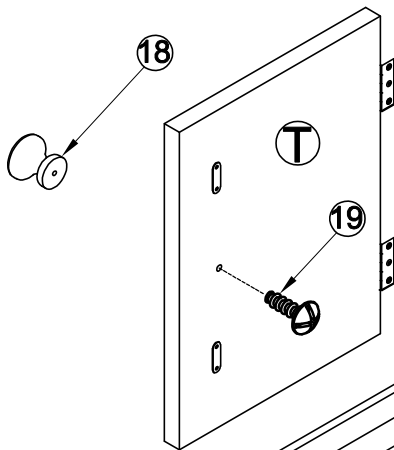

Detail 1

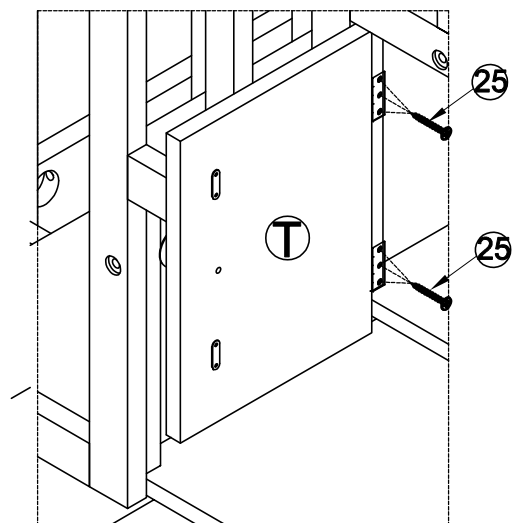

STEP 19

:CONGRARULATION. YOU HAVE COMPLETED THE BED. just one more step to push the Under Bed

Trundle into it position

