

ASSEMBLY INSTRUCTIONS

WE326001 - DINING TABLE

IMPORTANT NOTE :







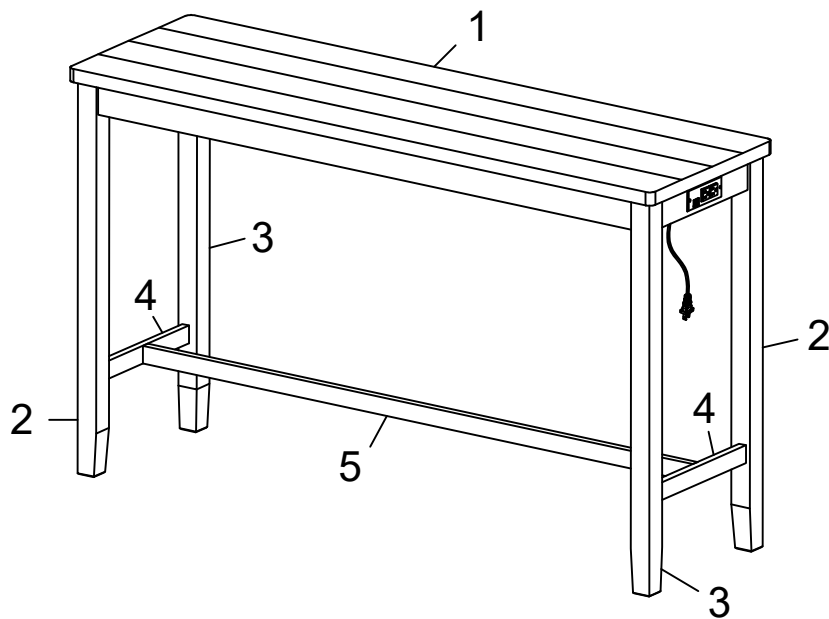

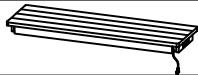

** PLACE ALL PARTS ON A CLEAN AND SMOOTH SURFACE SUCH AS A RUG OR CARPET TO AVOID THE PARTS FROM BEING SCRATCHED.

** BEFORE YOU BEGIN, KINDLY FOLLOW THE ASSEMBLY INSTRUCTIONS STEP BY STEP.

**DO NOT TIGHTEN ALL SCREWS AND BOLTS UNTIL THE TABLE IS FULLY SET-UP.



CARTONS ONLY ONE/ CARTONS SEULEMENT UN

PART LISTS				HARDWARE LISTS			
NO.	DESCRIPTION	SKETCH	Q'TY	NO.	DESCRIPTION	SKETCH	Q'TY
1	TABLE TOP		1 PC	A	BOLT Ø 5/16" x 60mmL		8 PCS
2	LEFT LEG		2 PCS	B	SPRING WASHER Ø 5/16" x 12 mm		8 PCS
3	RIGHT LEG		2 PCS	C	FLAT WASHER Ø 5/16" x 18 mm		8 PCS
4	SIDE STRETCHER		2 PCS	D	SCREW Ø 5/32"x40 mm		6 PCS
5	MIDDLE STRETCHER		1 PC	E	ALLEN WRENCH 4 mm		1 PC
							not included

MADE IN VIETNAM

1 OF 2

ASSEMBLY INSTRUCTIONS

STEP 1 :

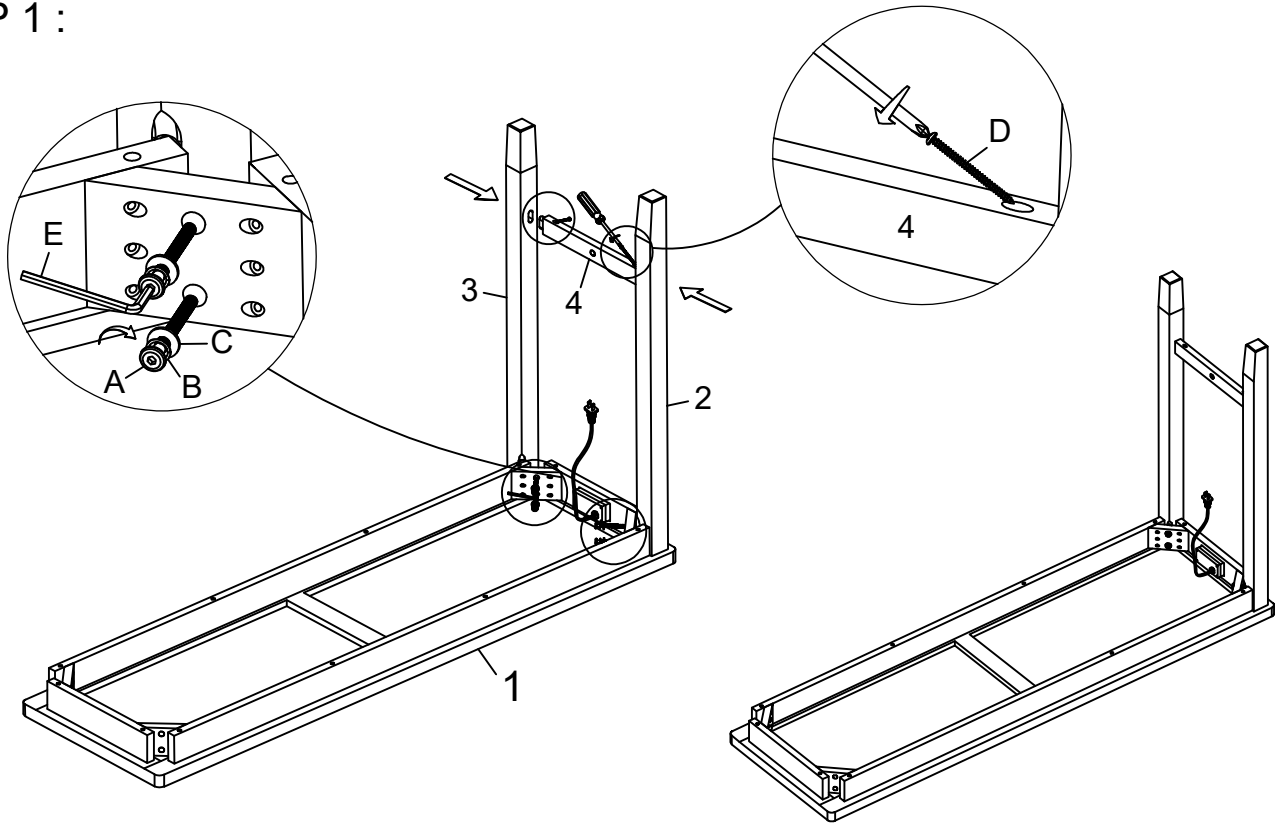

STEP 2 :

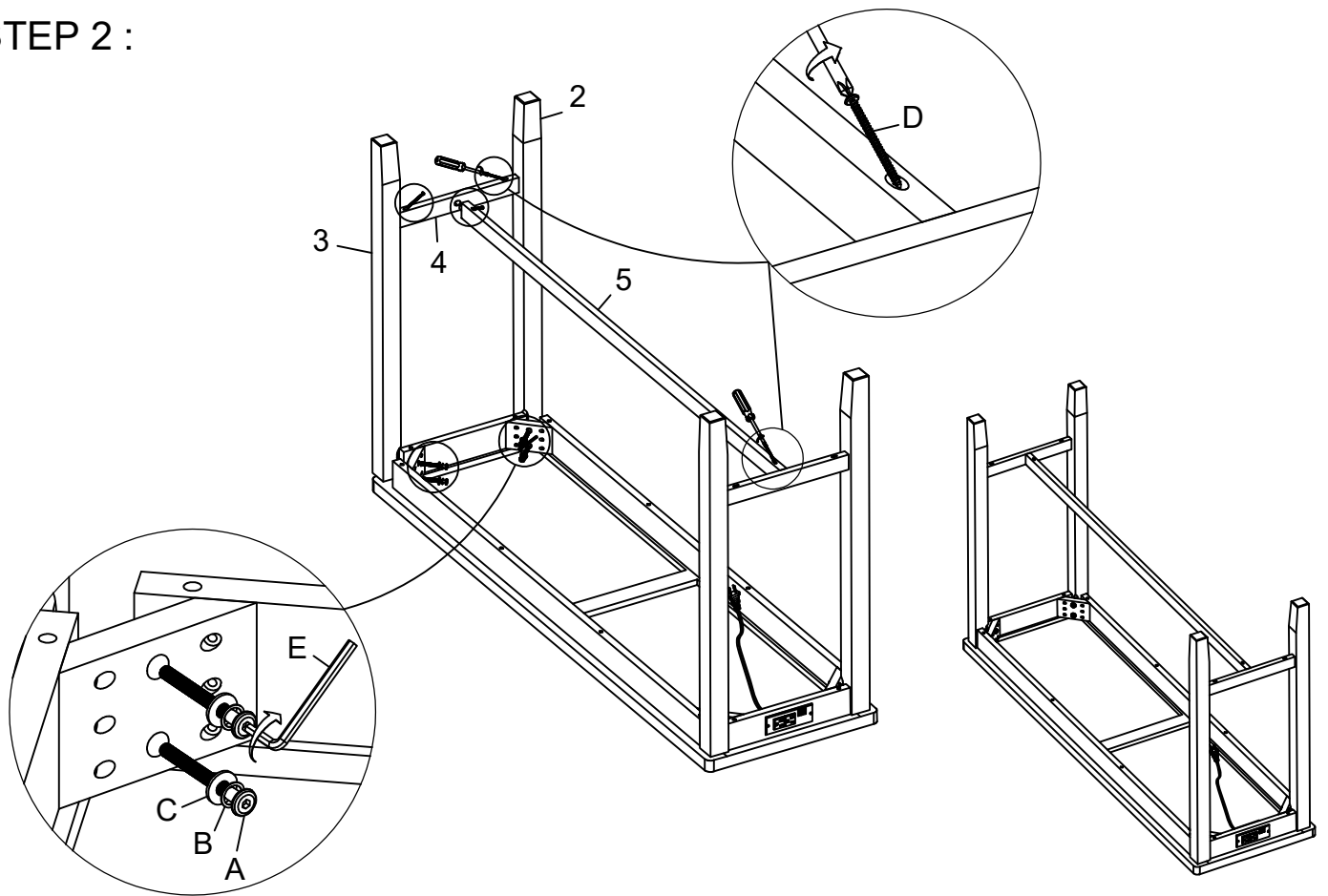

ASSEMBLY INSTRUCTIONS

STEP3 :

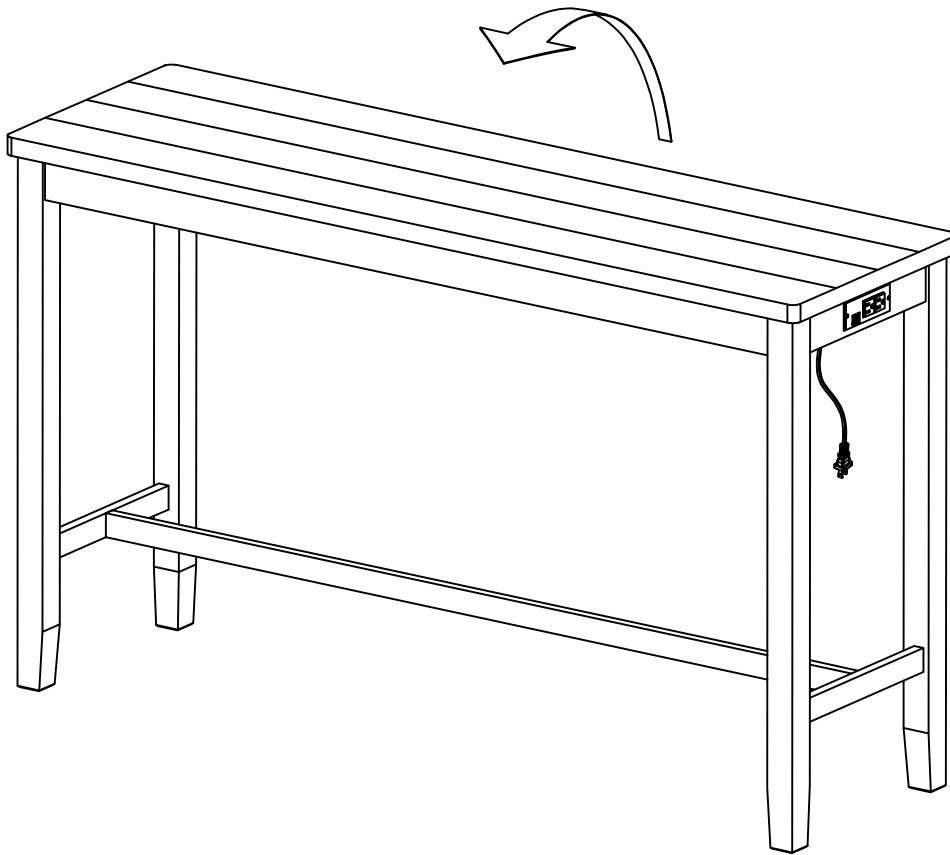

ASSEMBLY INSTRUCTIONS

WF326001 STOOL

IMPORTANT NOTE :







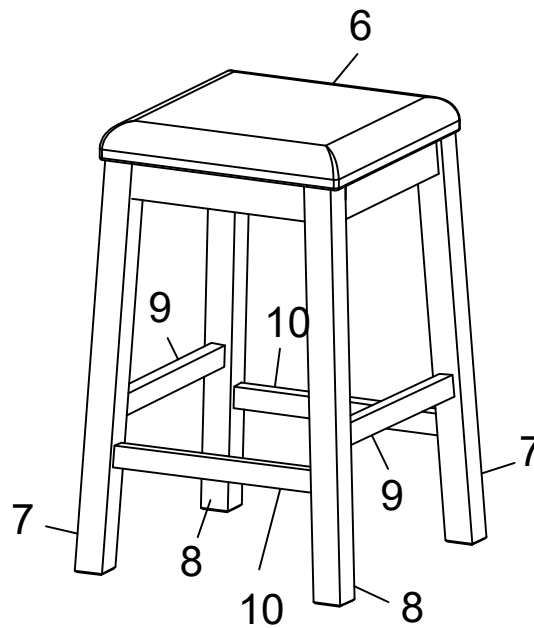



** PLACE ALL PARTS ON A CLEAN AND SMOOTH SURFACE SUCH AS A RUG OR CARPET TO AVOID THE PARTS FROM BEING SCRATCHED.

** BEFORE YOU BEGIN, KINDLY FOLLOW THE ASSEMBLY INSTRUCTIONS STEP BY STEP.

**DO NOT TIGHTEN ALL SCREWS AND BOLTS UNTIL THE STOOL IS FULLY SET-UP.



CARTONS ONLY ONE/ CARTONS SEULEMENT UN

PART LISTS				HARDWARE LISTS			
NO.	DESCRIPTION	SKETCH	Q'TY	NO.	DESCRIPTION	SKETCH	Q'TY
6	STOOL TOP		1 PC	F	BOLT Ø 1/4" x 60mmL		8 PCS
7	LEFT LEG		2 PCS	G	SPRING WASHER Ø 1/4" x 12 mm		8 PCS
8	RIGHT LEG		2 PCS	H	FLAT WASHER Ø 1/4" x 18 mm		8 PCS
9	LONG STRETCHER		2 PCS	I	SCREW Ø 5/32"x40 mm		8 PCS
10	SHORT STRETCHER		2 PCS	J	ALLEN WRENCH 4 mm		1 PC



not included

ASSEMBLY INSTRUCTIONS

STEP 1 :

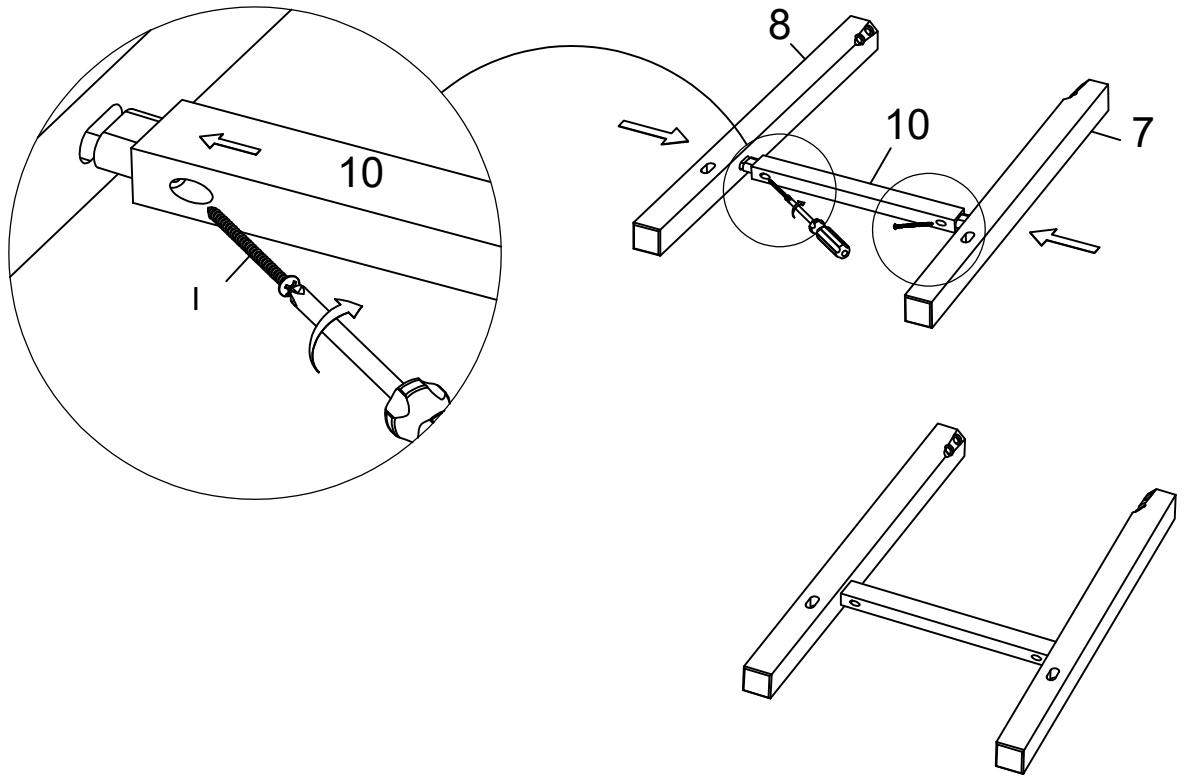

STEP 2 :

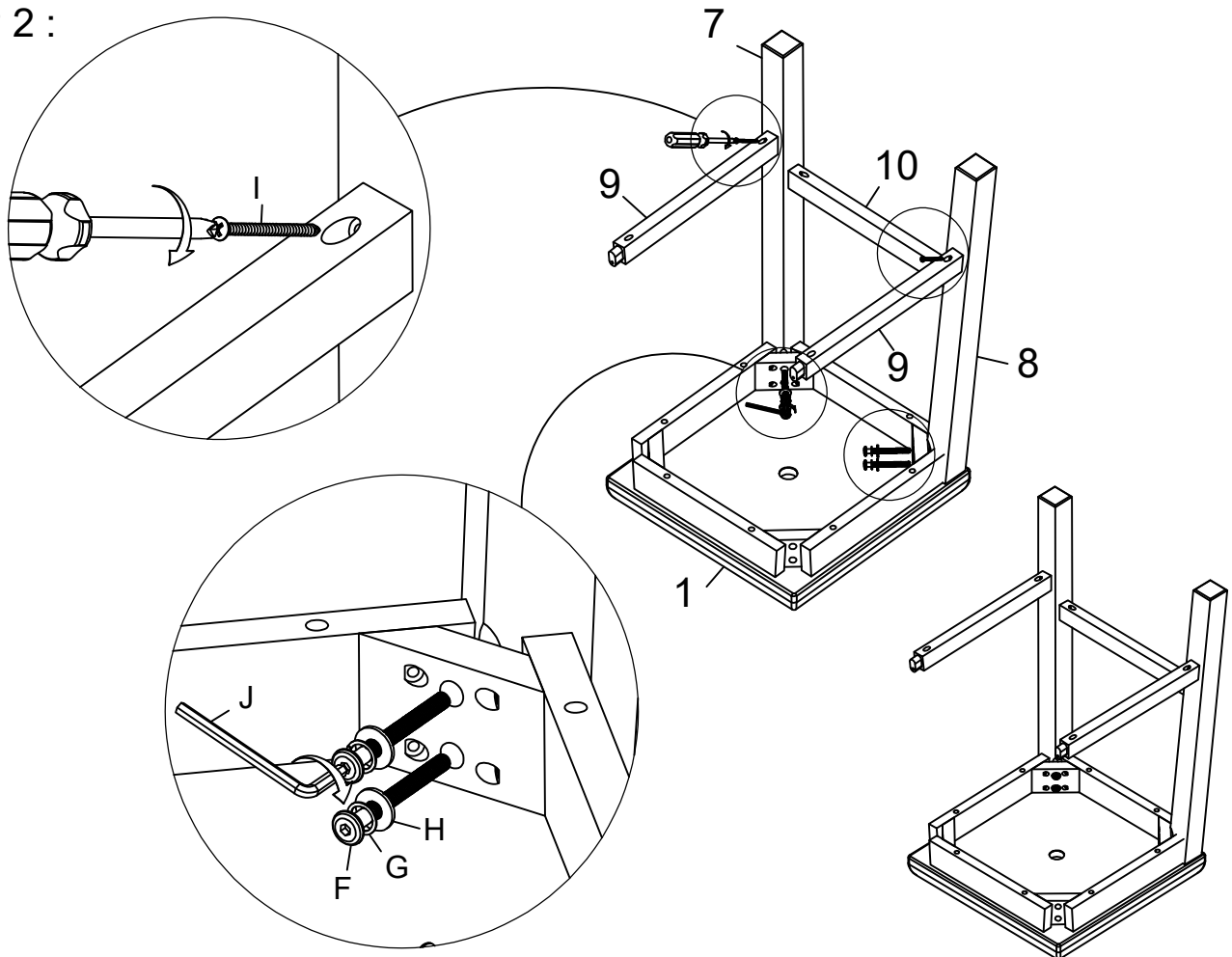

ASSEMBLY INSTRUCTIONS

STEP 3 :

