

ASSEMBLY INSTRUCTIONS

6PCS DINING TABLE SET

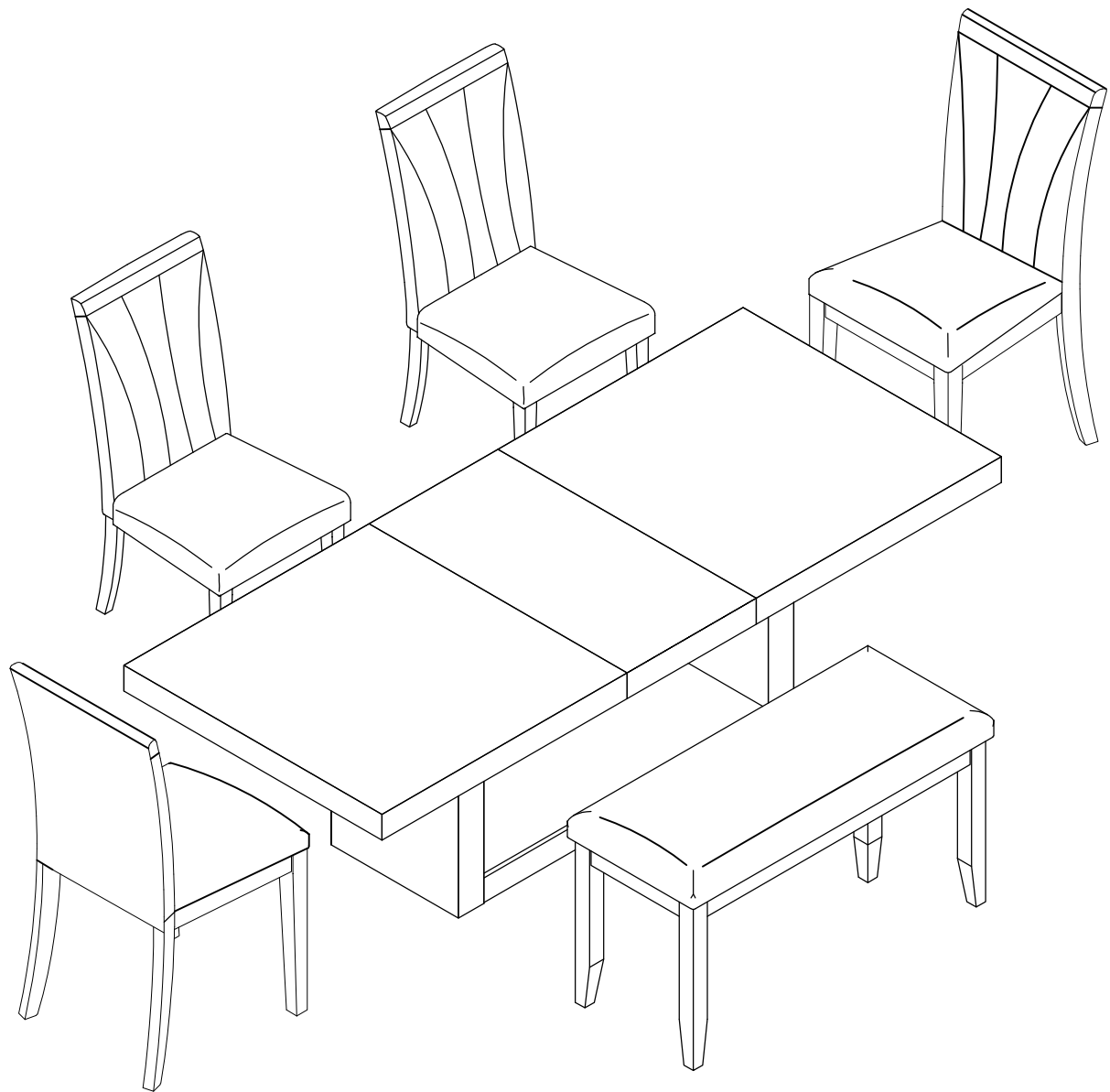

N717P171312 ; N717P171313 ; N717P171314

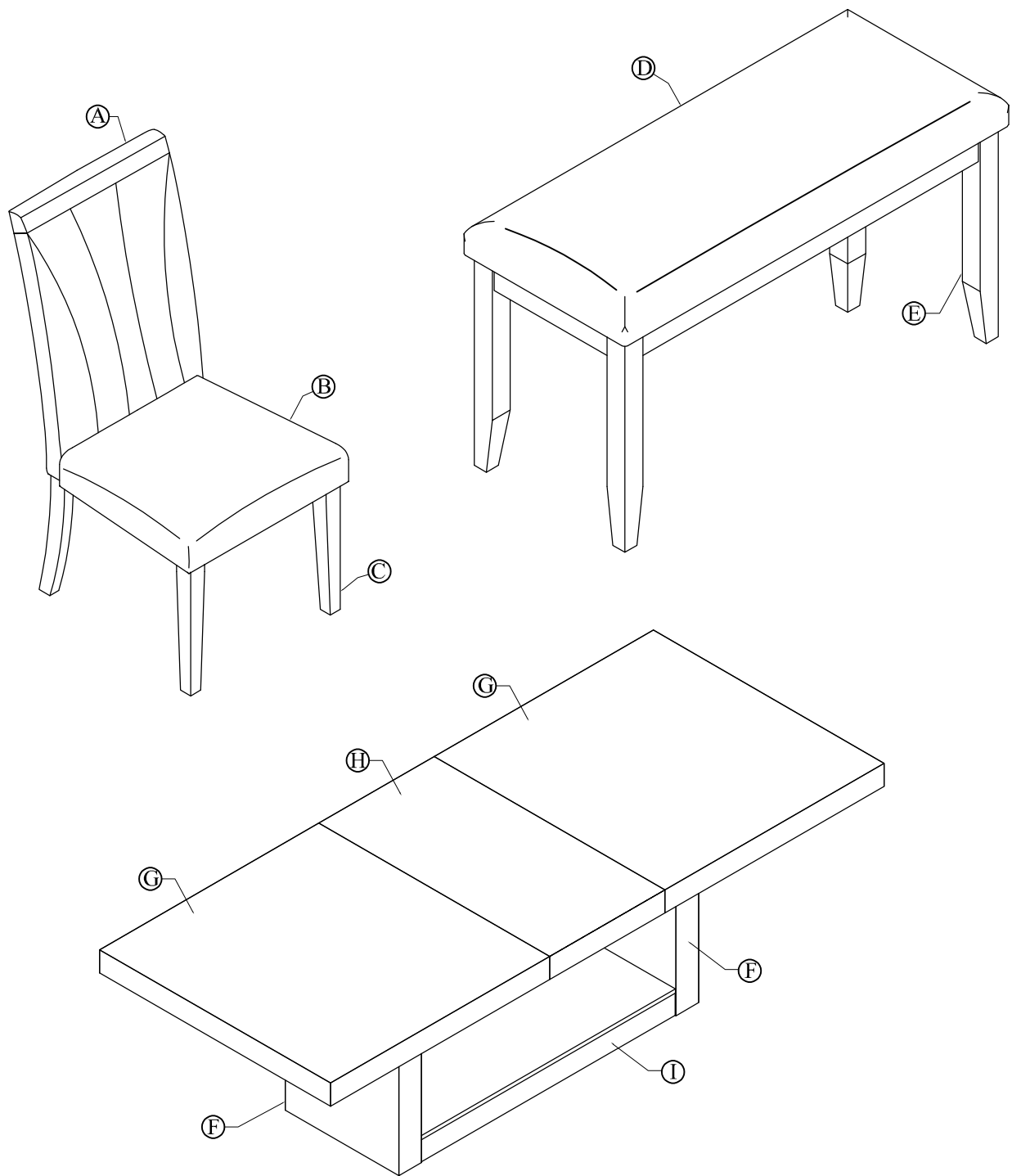

Notice:

1. 50% Tighten before fixing all screws, Allen wrench is recommended instead of an electric drill.
2. Place the item on a flat ground to adjust and make sure it remains stable.
3. Tighten up all screws with tools gradually.
4. If the screws are not aligned with holes during assembly, please loosen all other screws to 50% and continue the assembly process.
5. If the item is not stable, please loosen all the screws, adjust on a flat ground and tighten up all screws again.
6. Note: If one of some screws are fully tightened during assembly, chances are the others will not be aligned with holes. In addition, all the holes are designed to be relatively larger to provide more space for the adjustment of the screws.

CARTON CONTENT:

N717P171314:

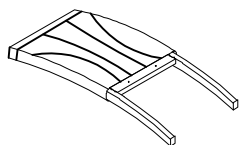

Ⓐ x4

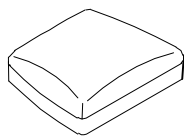

Ⓑ x4

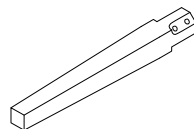

Ⓒ x8



N717P171313:

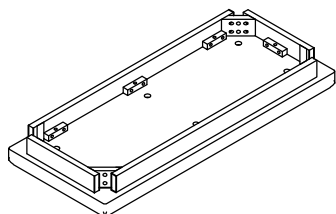

Ⓓ x1

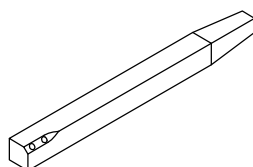

Ⓔ x4

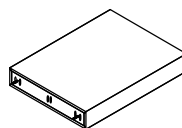

Ⓕ x2



N717P171312:

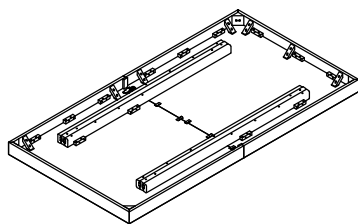

Ⓖ x1

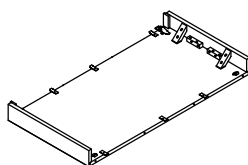

Ⓗ x1

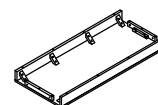

Ⓖ x1

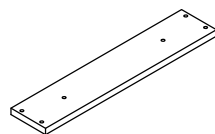





Ⓙ x2

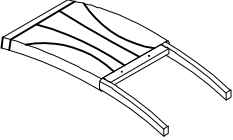
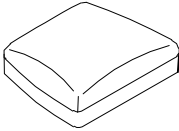
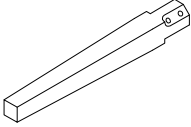
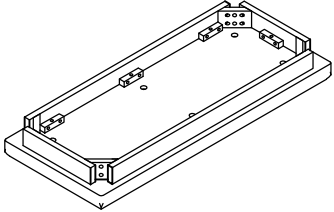
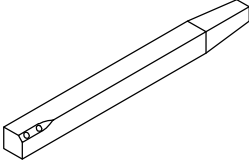
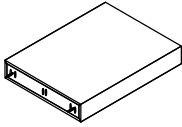
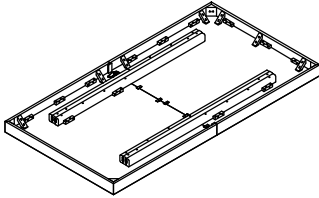
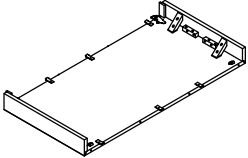
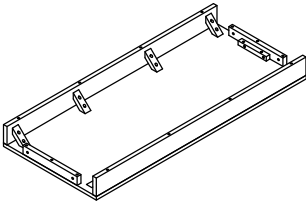
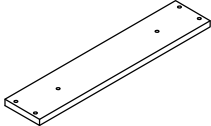



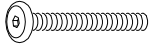

Part List

<p>A</p>  <p>4PCS</p>	<p>B</p>  <p>4PCS</p>	<p>C</p>  <p>8PCS</p>	<p>D</p>  <p>1PCS</p>
<p>E</p>  <p>4PCS</p>	<p>F</p>  <p>2PCS</p>	<p>G</p>  <p>1PCS</p>	<p>H</p>  <p>1PCS</p>
<p>I</p>  <p>1PCS</p>	<p>J</p>  <p>2PCS</p>		





CHAIR HARDWARE FOR ONE

<p>① x 4 PCS</p>  <p>BOLT Ø1/4 * 75 mm</p>	<p>② x 4 PCS</p>  <p>BOLT Ø1/4 * 50 mm</p>	<p>③ x 2 PCS</p>  <p>BOLT Ø1/4 * 45 mm</p>	<p>④ x 10 PCS</p>  <p>FLAT WASHER Ø1/4 * 13 mm</p>
<p>⑤ x 10 PCS</p>  <p>LOCK WASHER Ø1/4 * 19mm</p>	<p>⑥ x 1 PC</p>  <p>ALLEN KEY 4mm</p>		

BENCH HARDWARE

<p>① x 8 PCS</p>  <p>BOLT Ø1/4 * 60 mm</p>	<p>② x 8 PCS</p>  <p>FLAT WASHER Ø1/4 * 13 mm</p>	<p>③ x 8 PCS</p>  <p>LOCK WASHER Ø1/4 * 19mm</p>	<p>④ x 1 PC</p>  <p>ALLEN KEY 4mm</p>
------------------------------------------------------------------------------------------------------------------------------	----------------------------------------------------------------------------------------------------------------------------------------	----------------------------------------------------------------------------------------------------------------------------------------	------------------------------------------------------------------------------------------------------------------------------

DINING TABLE HARDWARE

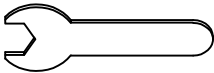
<p>① x 12 PCS</p>  <p>BOLT Ø5/16 * 45 mm</p>	<p>② x 4 PCS</p>  <p>HEX NUT Ø5/16 * 12 mm</p>	<p>③ x 16 PCS</p>  <p>SPRING WASHER Ø5/16 * 2 mm</p>	<p>④ x 16 PCS</p>  <p>FLAT WASHER Ø5/16 * 13 mm</p>
<p>⑤ x 1 PC</p>  <p>ALLEN KEY 4mm</p>	<p>⑥ x 1 PC</p>  <p>WRENCH 4mm</p>		

STEP 1:

Note: Legs are packed in the small box and stored in the bottom of seat cushion, please open the black cloth and take out for assembly.

- Ⓑ x1
- Ⓒ x2
- ② x4
- ④ x4
- ⑤ x4
- ⑥ x1

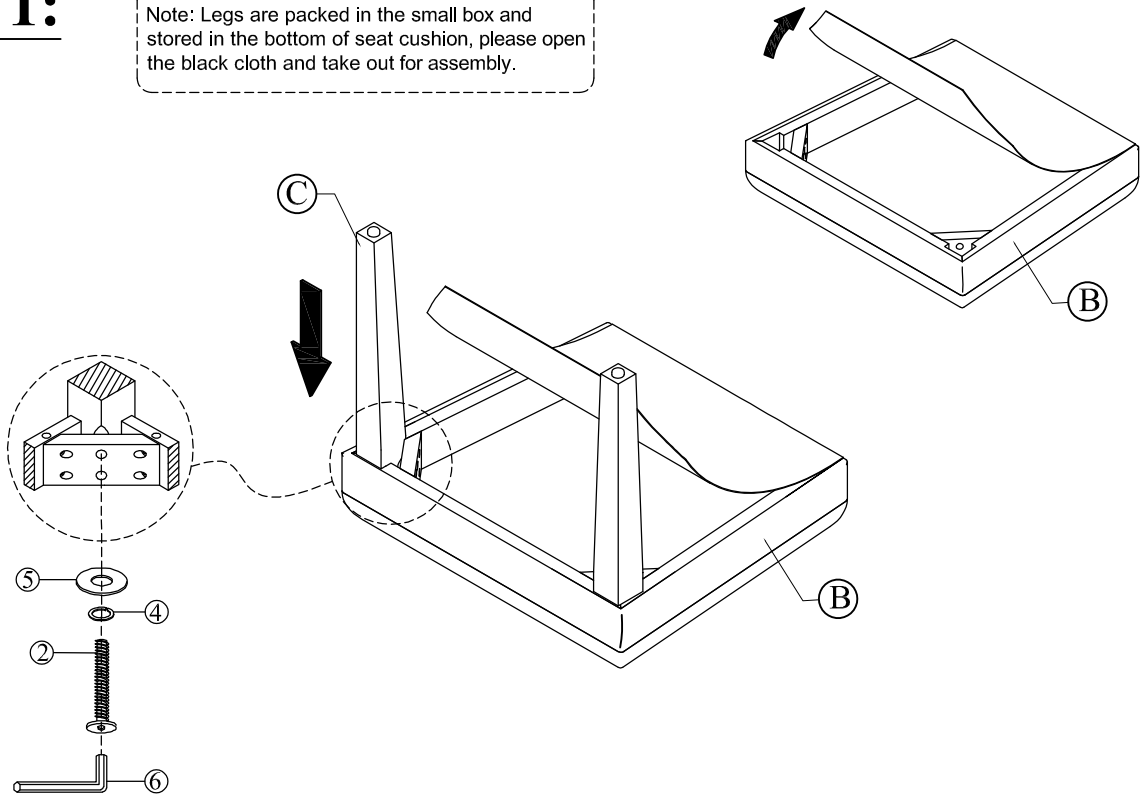

Connect the Front Leg (C) and Cushion seat (B), tighten Bolt (2), Flat Washer (4), Lock Washer (5) with Allen Key (6)

STEP 2:

- Ⓐ x1
- ① x4
- ③ x2
- ④ x6
- ⑤ x6
- ⑥ x1

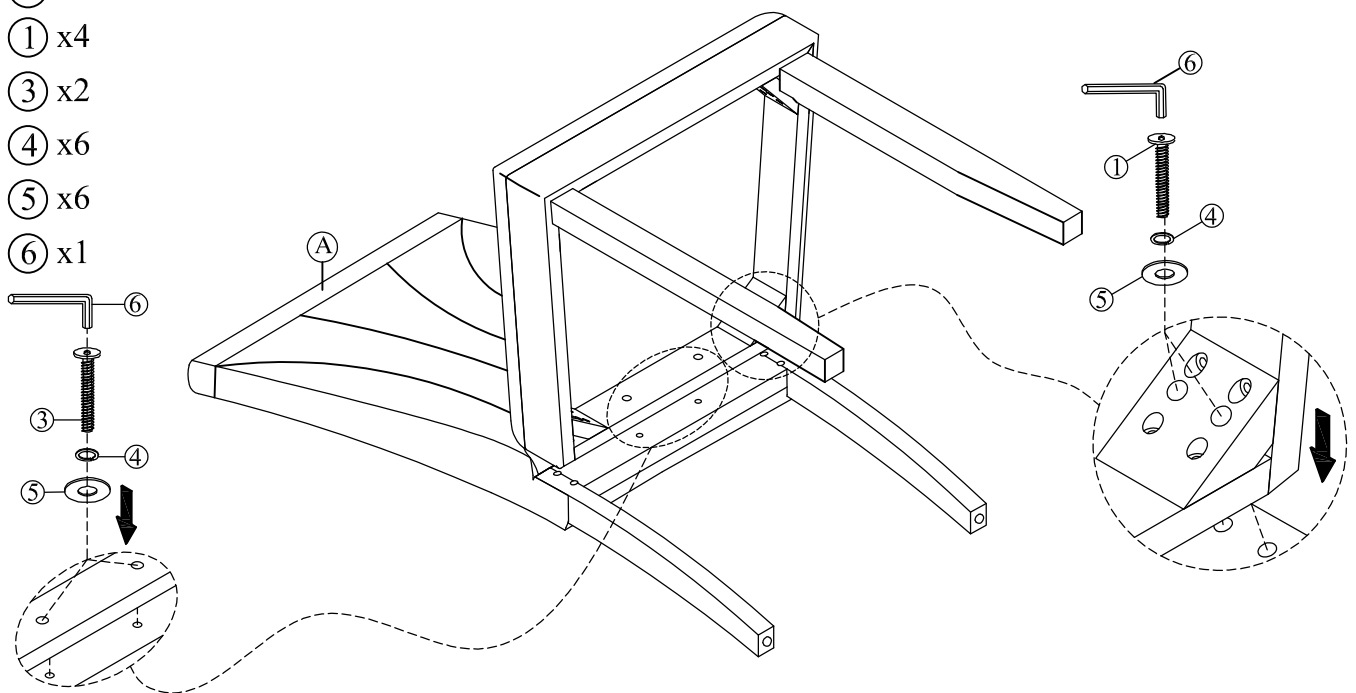

Connect the Part from Step 1 and Chair Back (A), tighten Bolt (1), Bolt (3), Flat Washer (4), Lock Washer (5) with Allen Key (6)

STEP 3:

Ⓓ x1

Ⓔ x4

① x8

② x8

③ x8

④ x1

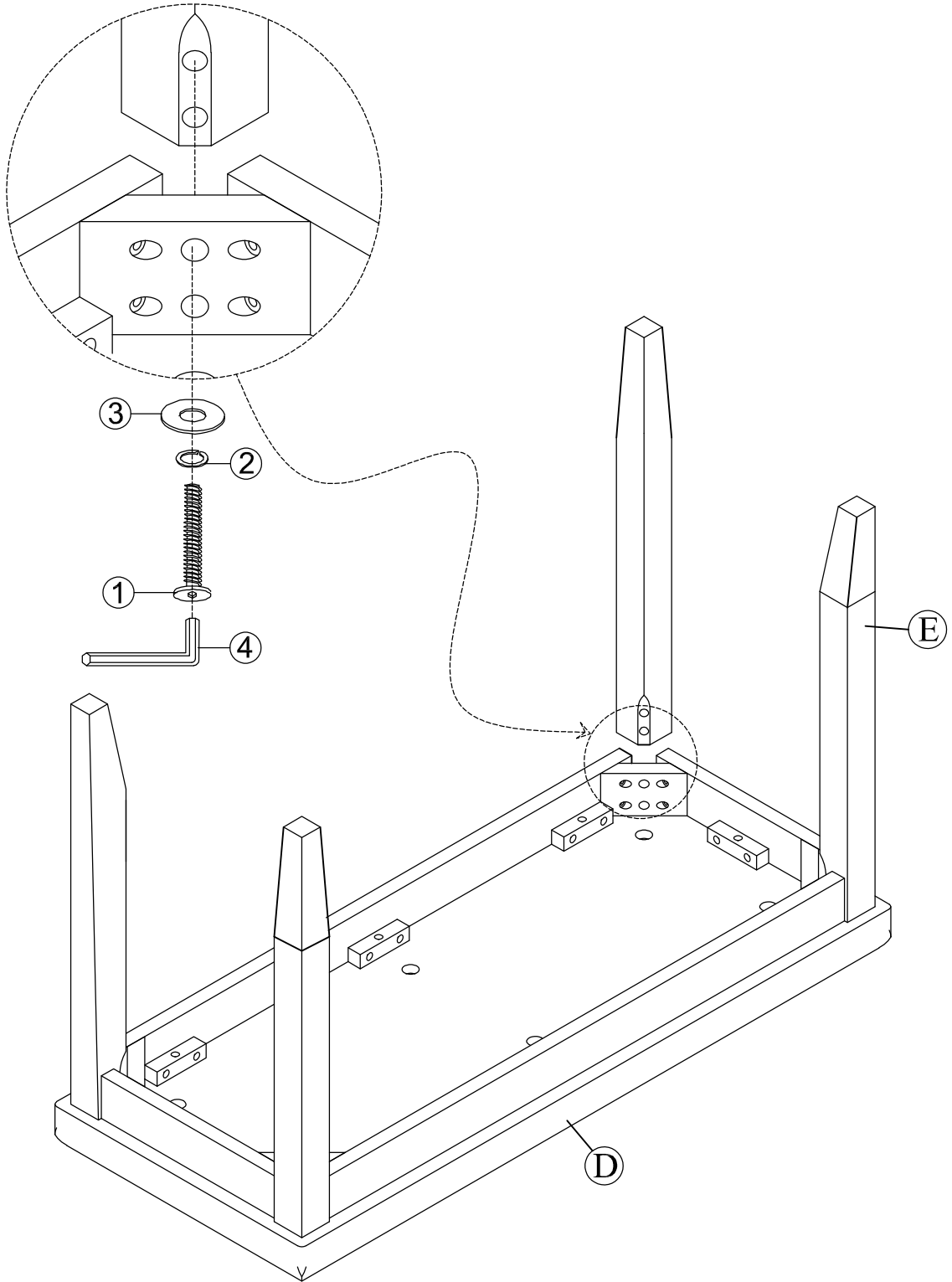

Connect the Leg (E) and Cushion seat (D), tighten Bolt (1), Flat Washer (2), Lock Washer (3) with Allen Key (4)

STEP 4:

- ⓕ x2
- Ⓢ x1
- ① x4
- ③ x4
- ④ x4
- ⑤ x1

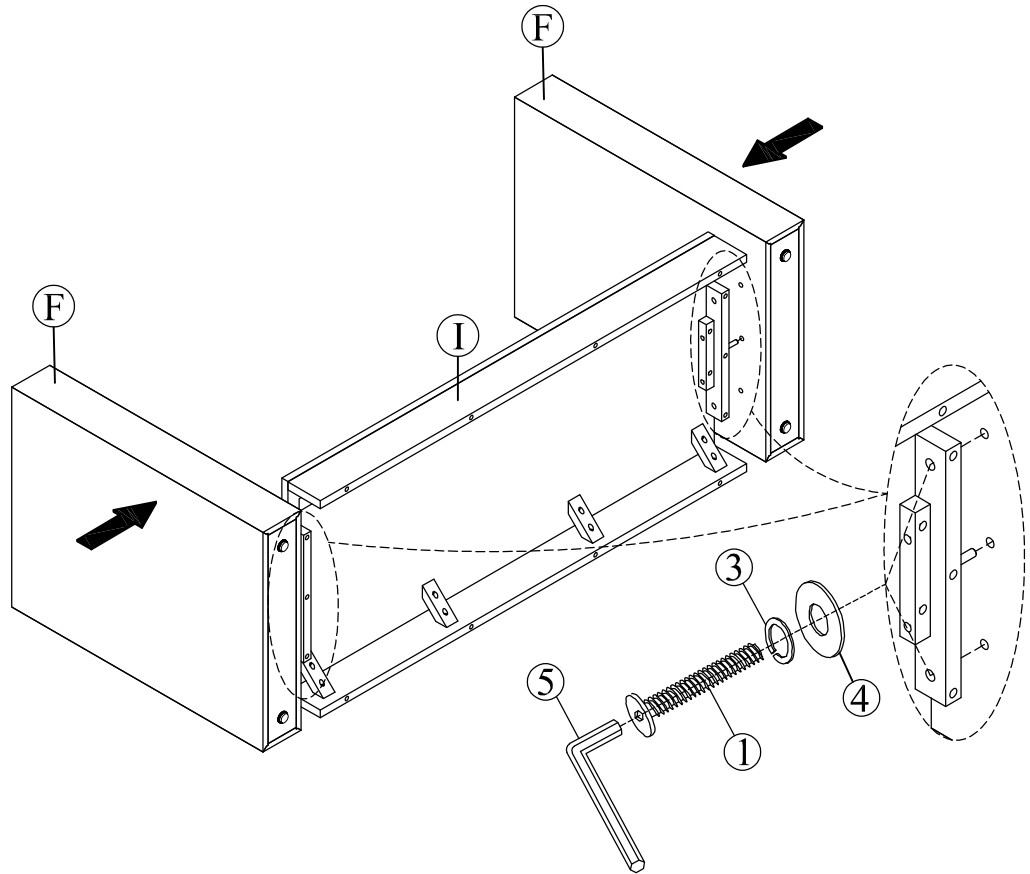

Connect the Leg (F) and Table base center (I), tighten Bolt (1), Flat Washer (3), Lock Washer (4) with Allen Key (5)

STEP 5:

- ⓙ x2
- ② x4
- ③ x4
- ④ x4
- ⑥ x1

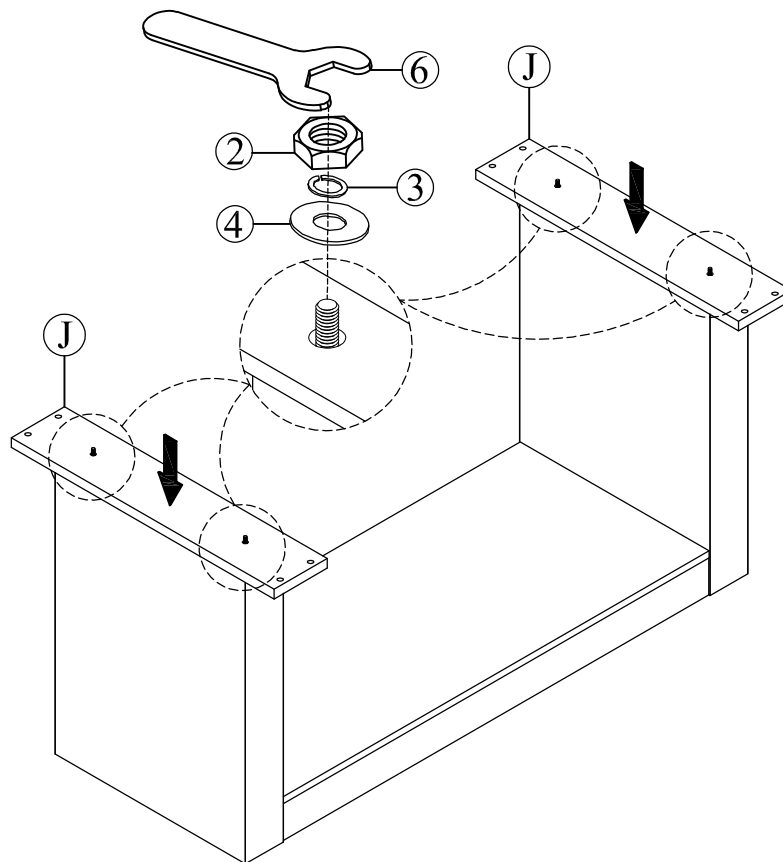

Connect the Part from Step 1 and Panel (J), tighten Hex nut (2), Flat Washer (3), Lock Washer (4) Wrench (6)

STEP 6:

- ⓐ x1
- ⓑ x8
- ⓒ x8
- ⓓ x8
- ⓔ x1

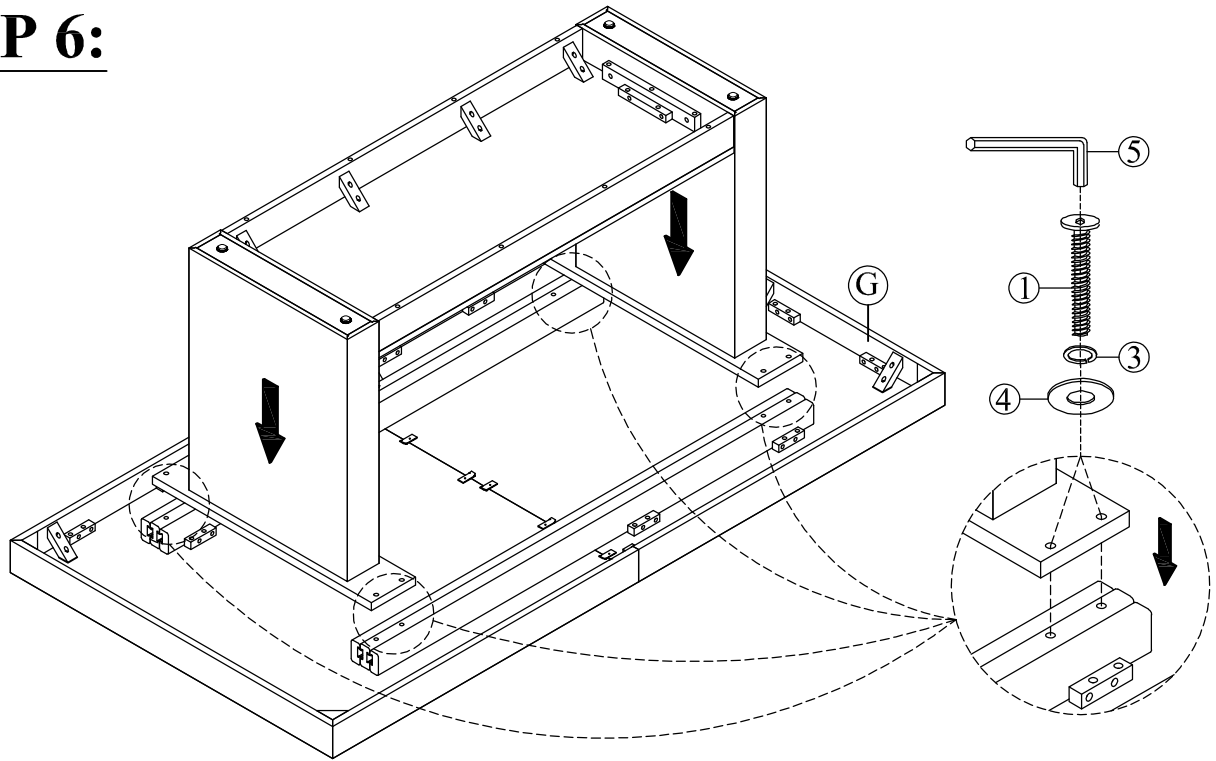

Connect the Part from Step 2 and Top Panel (G),tighten Bolt (1), Flat Washer (3), Lock Washer (4) with Allen Key (5)

STEP 7:

- ⓗ x1

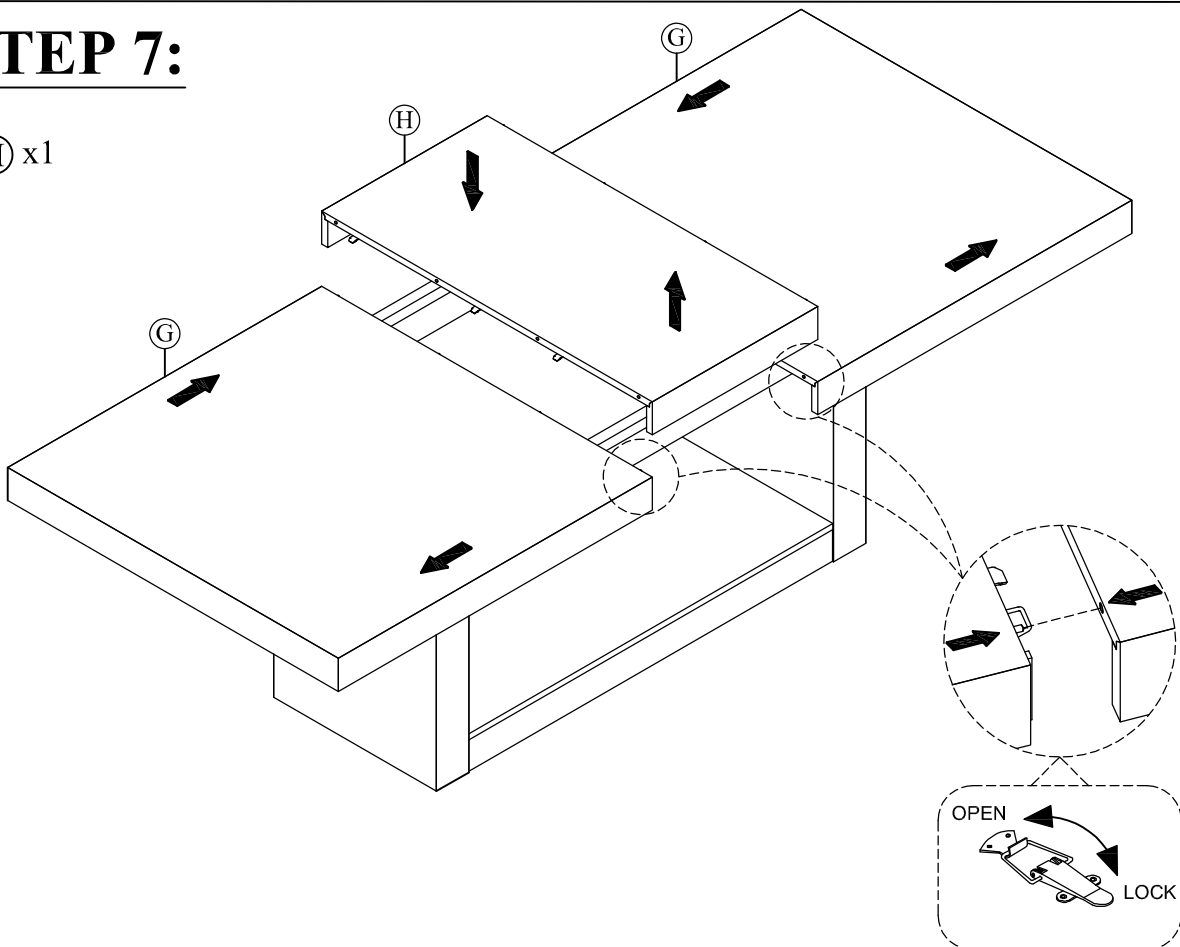

Open the 4 lockers under the Top Panel (G), drag them to side , put the Medium Panel (H) into the middle, fit the position then close the lockers.