

ASSEMBLY INSTRUCTIONS

DINING TABLE

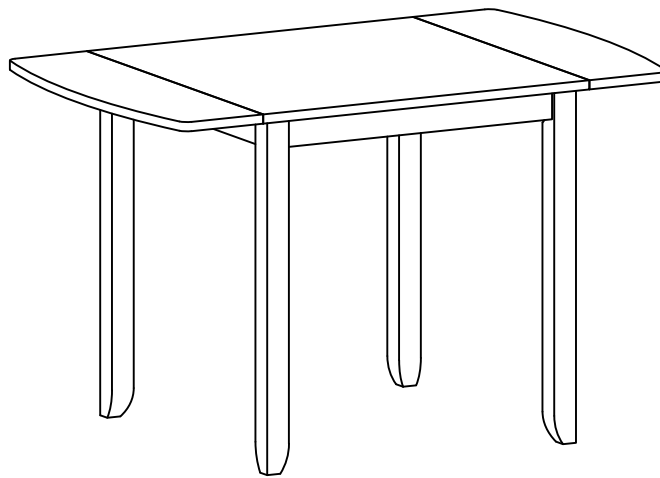

WF308166

IMPORTANT NOTE:

- PLACE ALL PARTS ON A CLEAN AND SMOOTH SURFACE SUCH AS A RUG OR CARPET TO AVOID THE PARTS FROM BEING SCRATCHED.
- BEFORE YOU BEGIN, KINDLY FOLLOW THE ASSEMBLY INSTRUCTIONS STEP BY STEP.
- DO NOT TIGHTEN ALL SCREWS AND BOLTS UNTIL THE TABLE IS FULLY SET-UP.

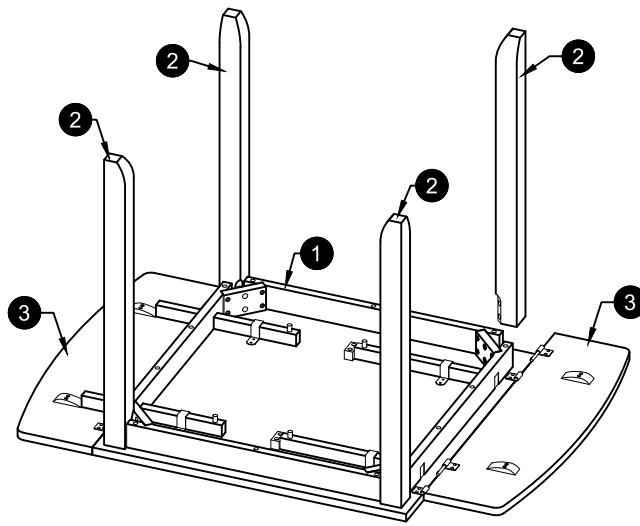

CARTON CONTENT:

WF308166 :

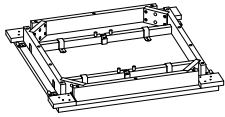

1 x 1



2 x 4



3 x 2

TABLE PART LISTS





NO.	DESCRIPTION	SKETCH	QTY
1	TABLE TOP		1 PC
2	TABLE LEG		4 PCS
3	LEAF		2 PCS

TABLE HARDWARE LISTS

NO.	DESCRIPTION	SKETCH	QTY
A	HEX COMB 5/16 x 2 1/2"		8 PCS
B	SPRING WASHER 5/16"		8 PCS
C	FLAT WASHER 5/16"		8 PCS
D	SPANNER 1.28		1 PC

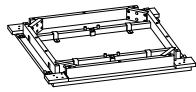
STEP 1

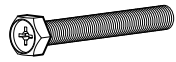

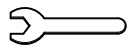
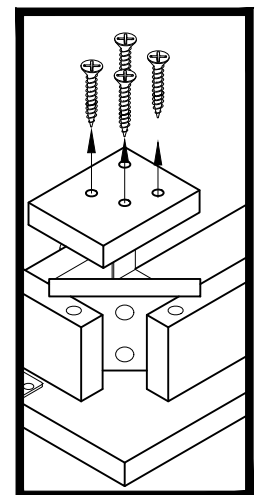
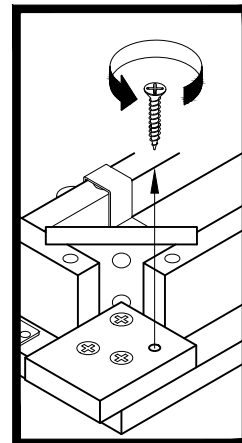
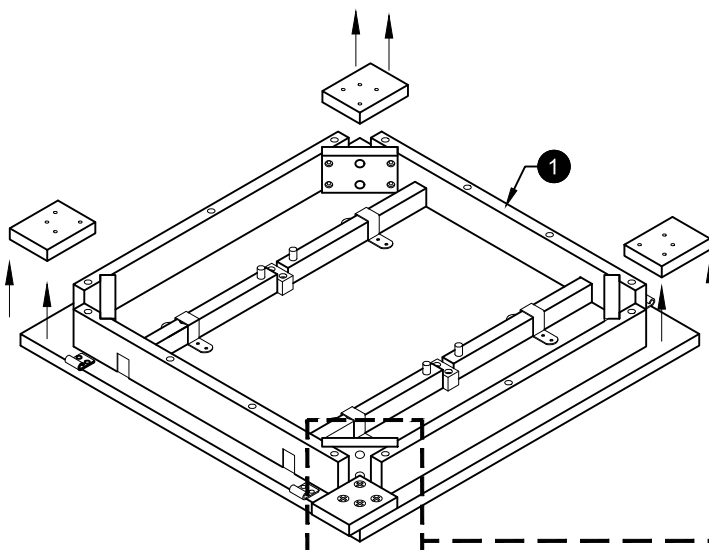
STEP 2

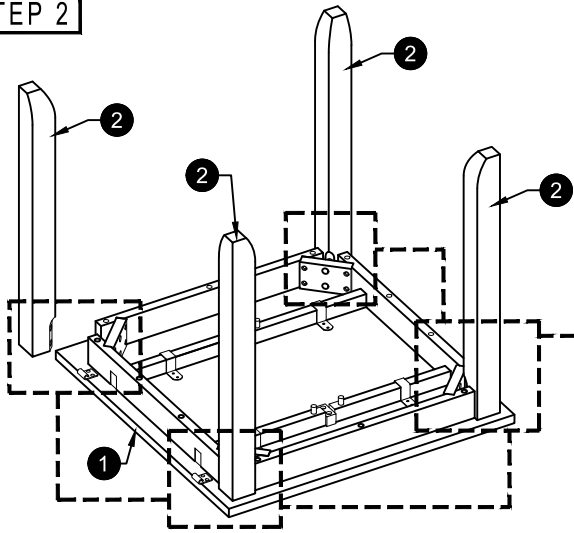

STEP 3

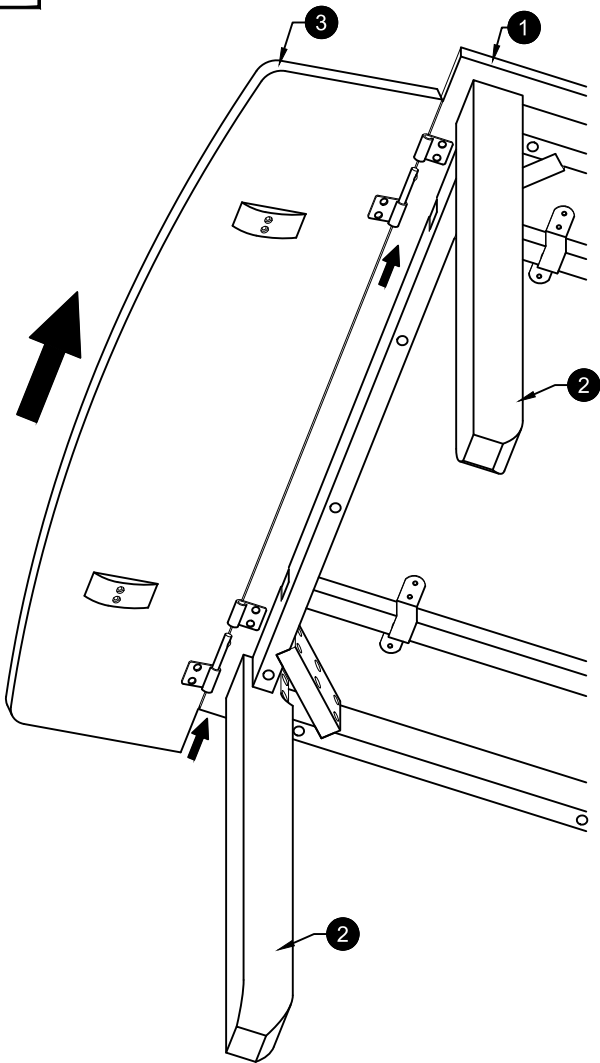

STEP 4

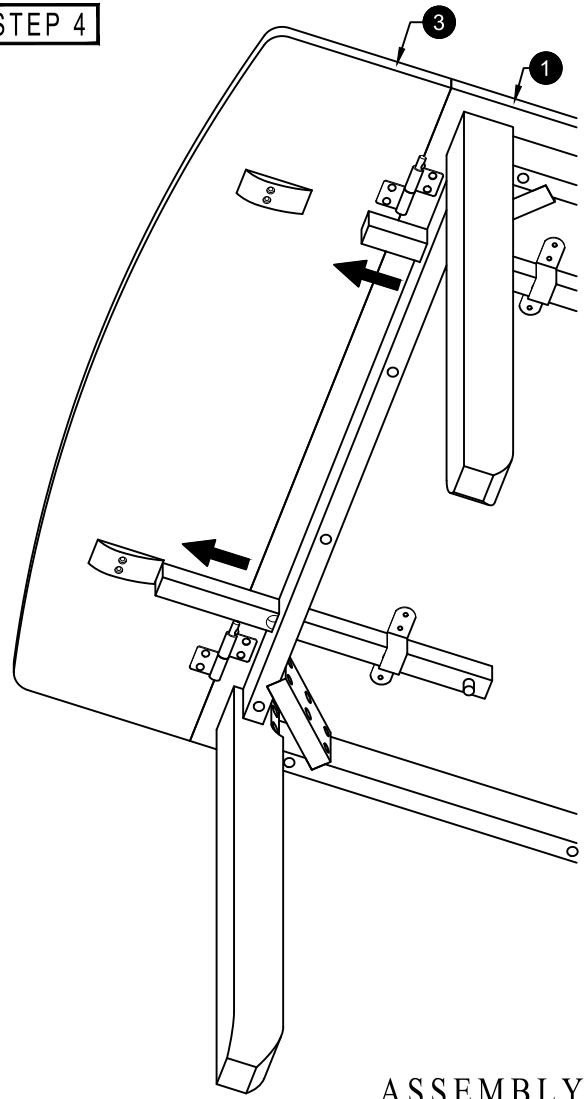

ASSEMBLY
COMPLETE !

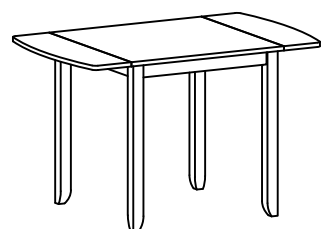

ASSEMBLY INSTRUCTIONS

DINING CHAIR

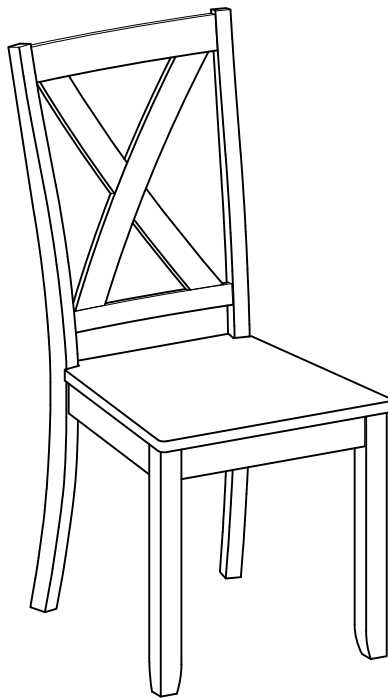

WF308167

IMPORTANT NOTE:

- PLACE ALL PARTS ON A CLEAN AND SMOOTH SURFACE SUCH AS A RUG OR CARPET TO AVOID THE PARTS FROM BEING SCRATCHED.
- BEFORE YOU BEGIN, KINDLY FOLLOW THE ASSEMBLY INSTRUCTIONS STEP BY STEP.
- DO NOT TIGHTEN ALL SCREWS AND BOLTS UNTIL THE CHAIR IS FULLY SET-UP.

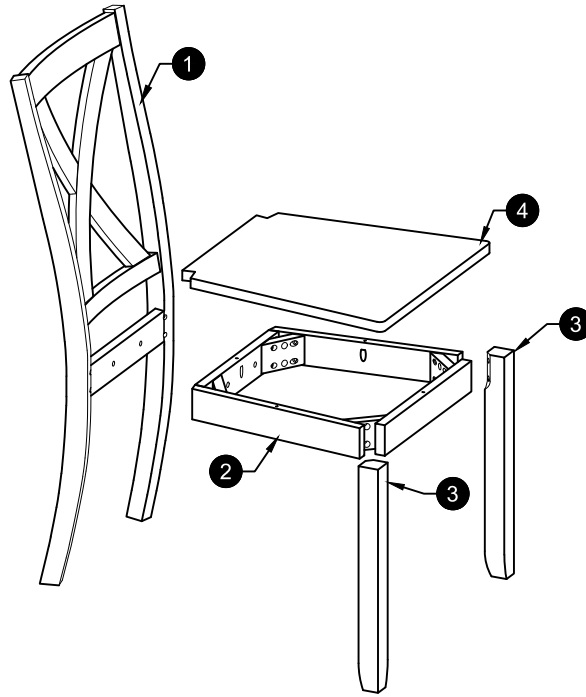

CARTON CONTENT:

WF308167 :

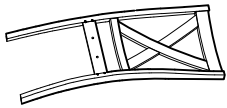

1 x 2

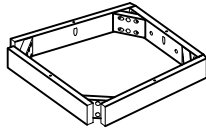

2 x 2



3 x 4

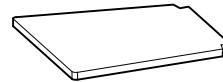

4 x 2

CHAIR PART LISTS

NO.	DESCRIPTION	SKETCH	QTY
1	BACK LEG		2 PCS
2	BOX SEAT		2 PCS
3	FRONT LEG		4 PCS
4	SEAT		2 PCS

CHAIR HARDWARE LISTS

NO.	DESCRIPTION	SKETCH	QTY
A	JCBC BOLT M6 x 35mm		4 PCS
B	JCBC BOLT M6 x 60mm		8 PCS
C	JCBC BOLT M6 x 80mm		8 PCS
D	SPRING WASHER 1/4"		20 PCS
E	FLAT WASHER 1/4"		20 PCS
F	ALLEN KEY M4		1 PC
G	C/B SCREW M4 x 30mm		8 PCS

STEP 1

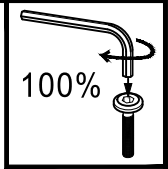
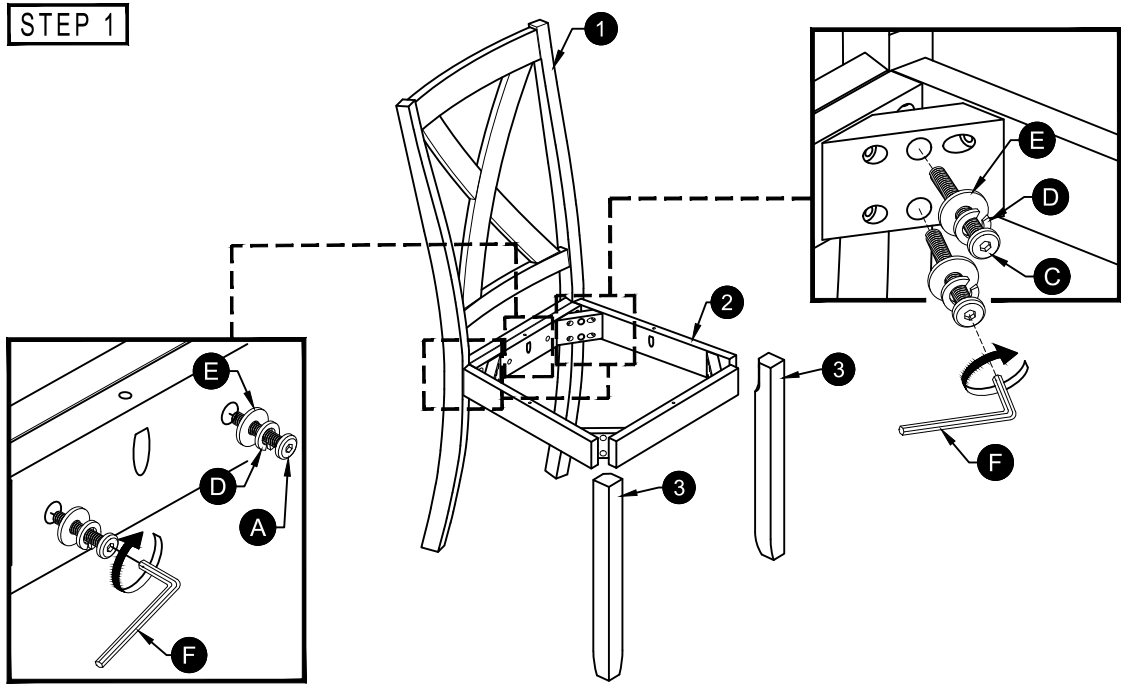

STEP 2

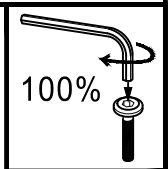
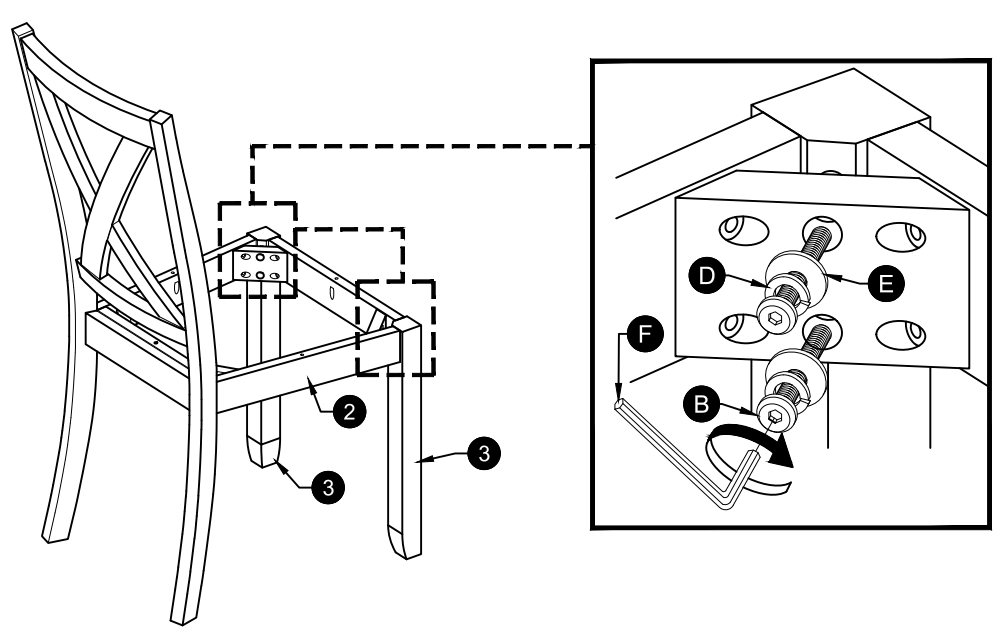

STEP 3

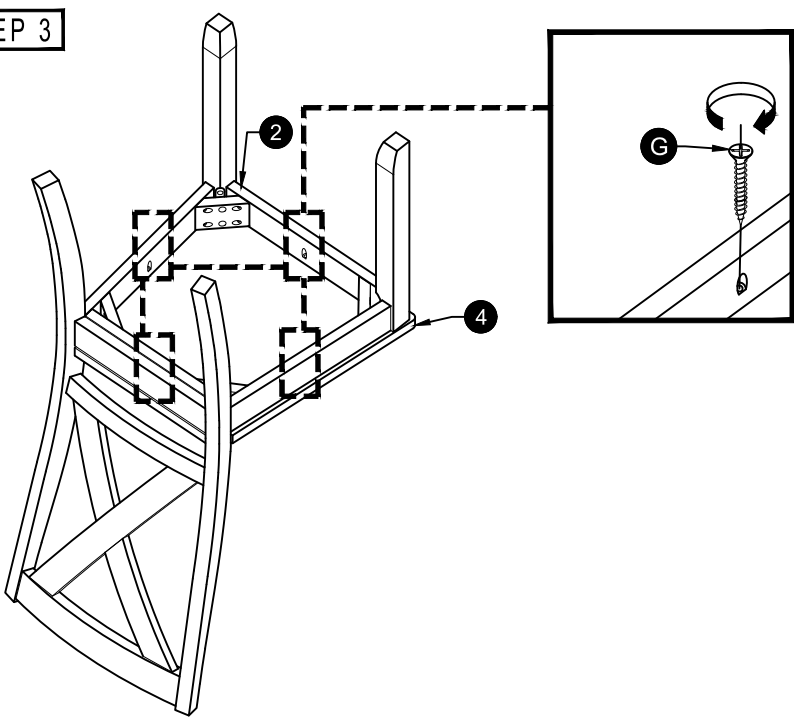

ASSEMBLY COMPLETE !