

Carton Content

WF310632





A	TOP PANEL		1pcs
B	LFAF		2pcs





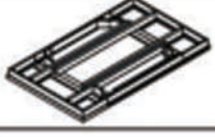

Table Hardware

WF310633

A	BACK FRAME		1pcs	x4
B	SEAT FRAME		1pcs	x4
C	FRONT LEGS		2pcs	x4

Chair Hardware

WF310634

C	LEGS (LEFT)		2pcs
D	LEGS (RIGHT)		2pcs
E	SIDE STRETCHER		2pcs
F	MIDDLE STRETCHER		1pcs
A	SEAT FRAME		1pcs
B	LEGS		4pcs

Bench Hardware

ASSEMBLY INSTRUCCIONES

ITEM NOTE : WF310632

DINING TABLE

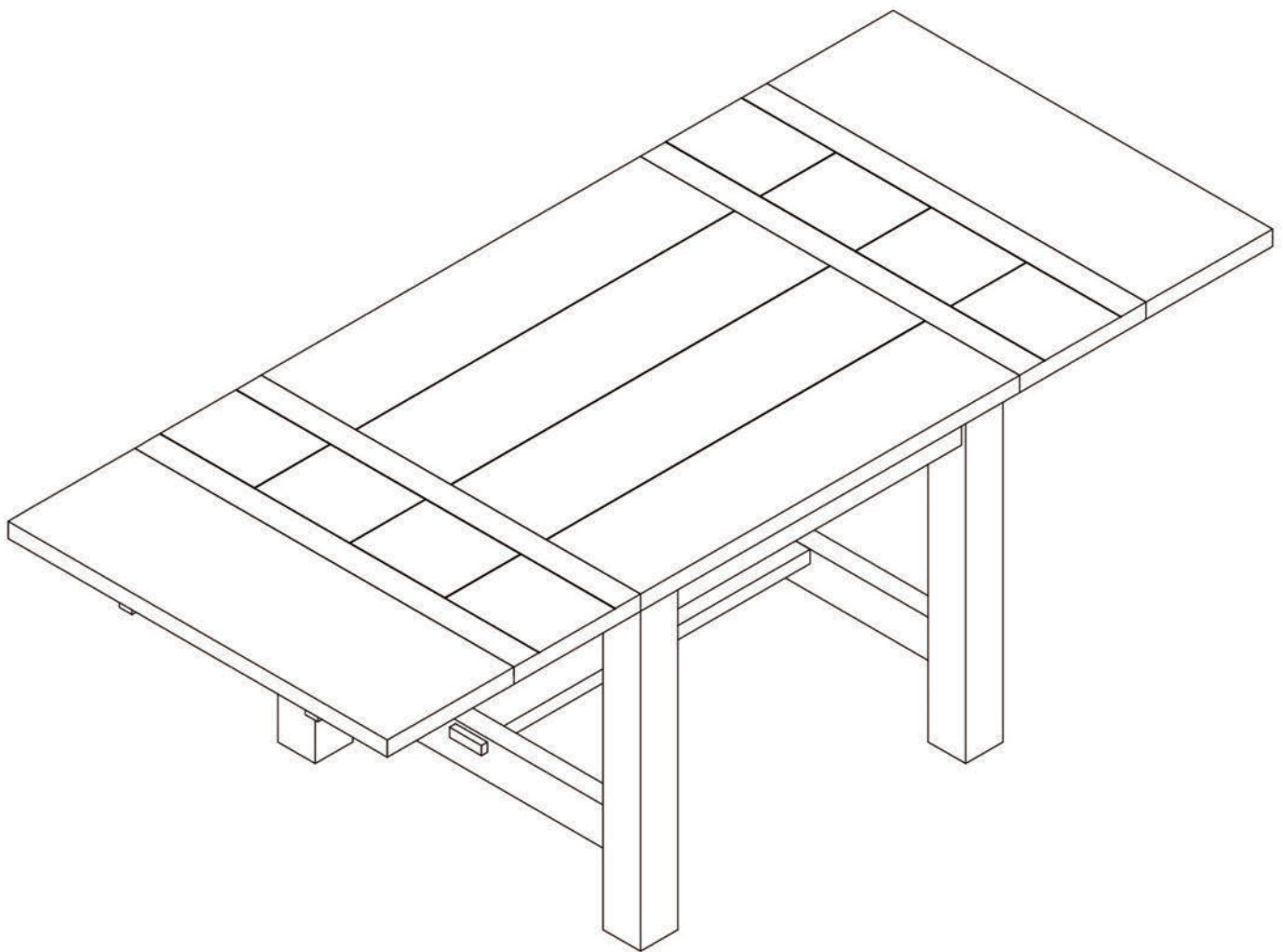





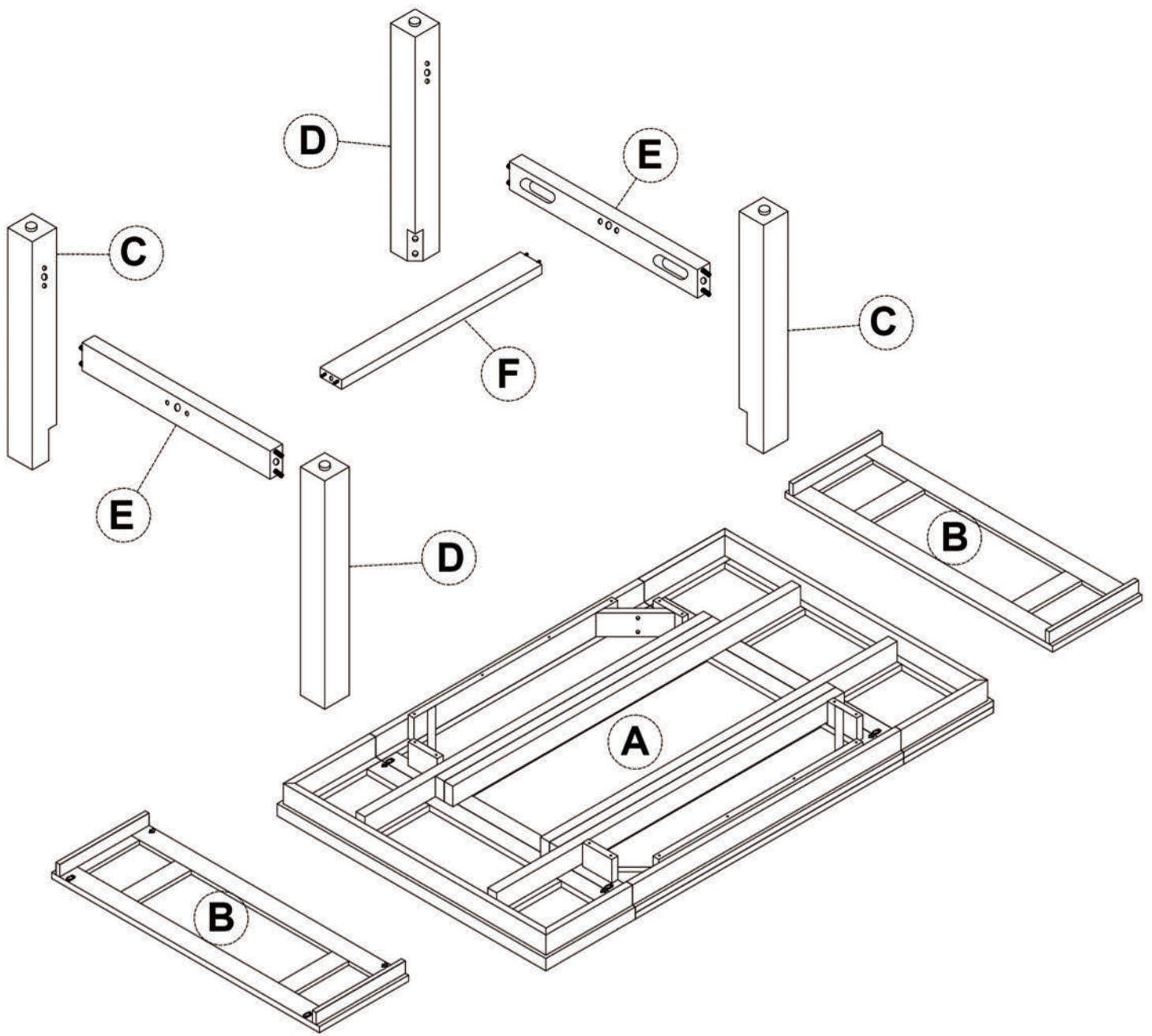



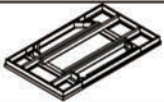

IMPORTANT NOTE:

- ① PLACE ALL PARTS ON A CLEAN AND SMOOTH SURFACE SUCH AS A RUG OR CARPET TO AVOID THE PARTS FROM BEING SCRATCHED.
- ② BEFORE YOU BEGIN, KINDLY FOLLOW THE ASSEMBLY INSTRUCTIONS STEP BY STEP.
- ③ DO NOT TIGHTEN ALL SCREWS AND BOLTS UNTIL THE TABLE IS FULLY SET-UP







Part List For One

Hardware List For One

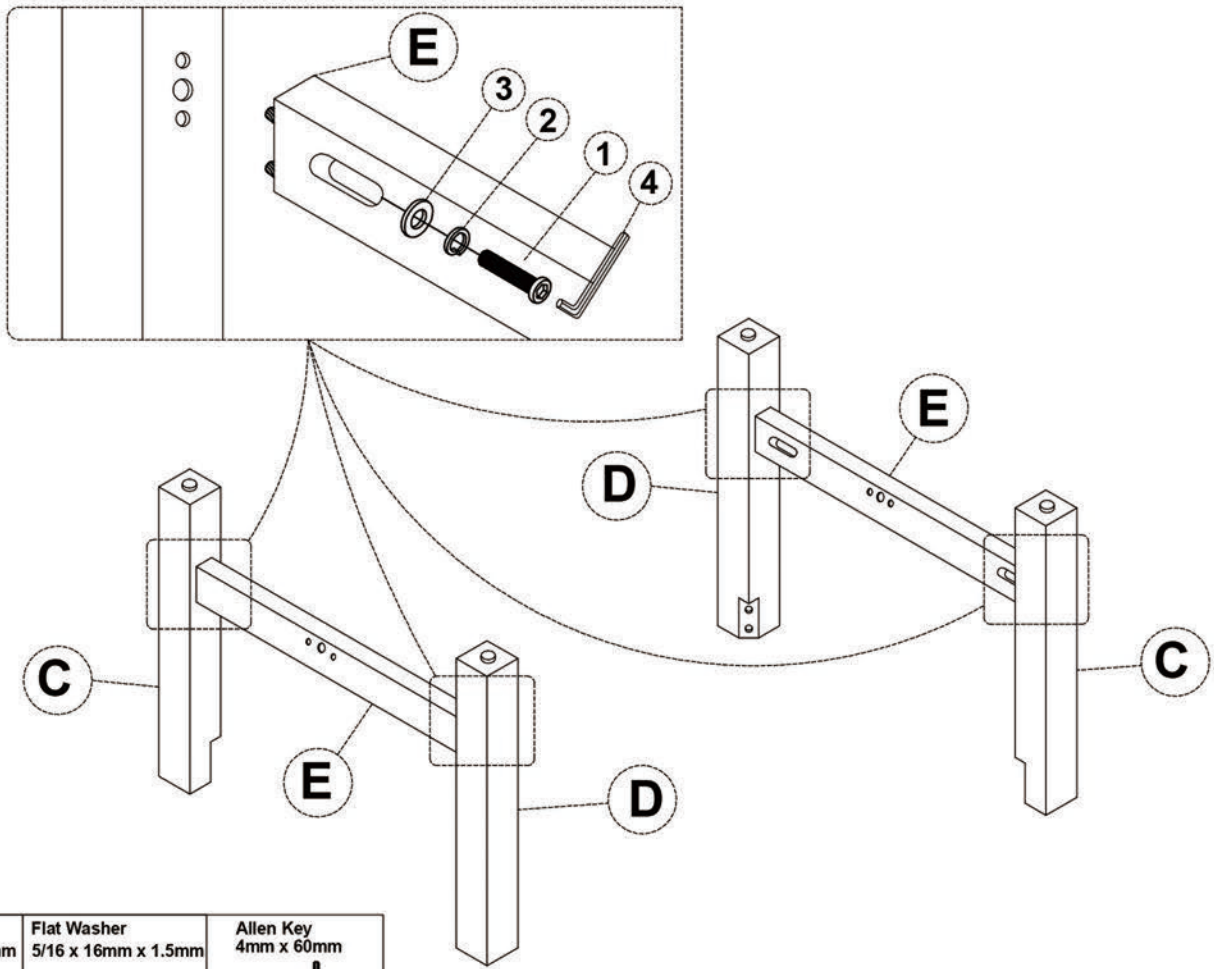
No	Parts Desc.	Q'ty	No	Hardware Desc.	Q'ty
A	TOP PANEL 	1pcs	1	Bolts 5/16"× 60mm 	14pcs
B	LFAF 	2pcs	2	Spring Washer 5/16"× 13mm x 1.5mm 	14pcs
C	LEGS (LEFT) 	2pcs	3	Flat Washer 5/16"× 16mm x 1.5mm 	14pcs
D	LEGS (RIGHT) 	2pcs	4	Allen Key 4mm×60mm 	1pcs
E	SIDE STRETCHER 	2pcs	5	Ornament 	2pcs
F	MIDDLE STRETCHER 	1pcs			





STEP 1

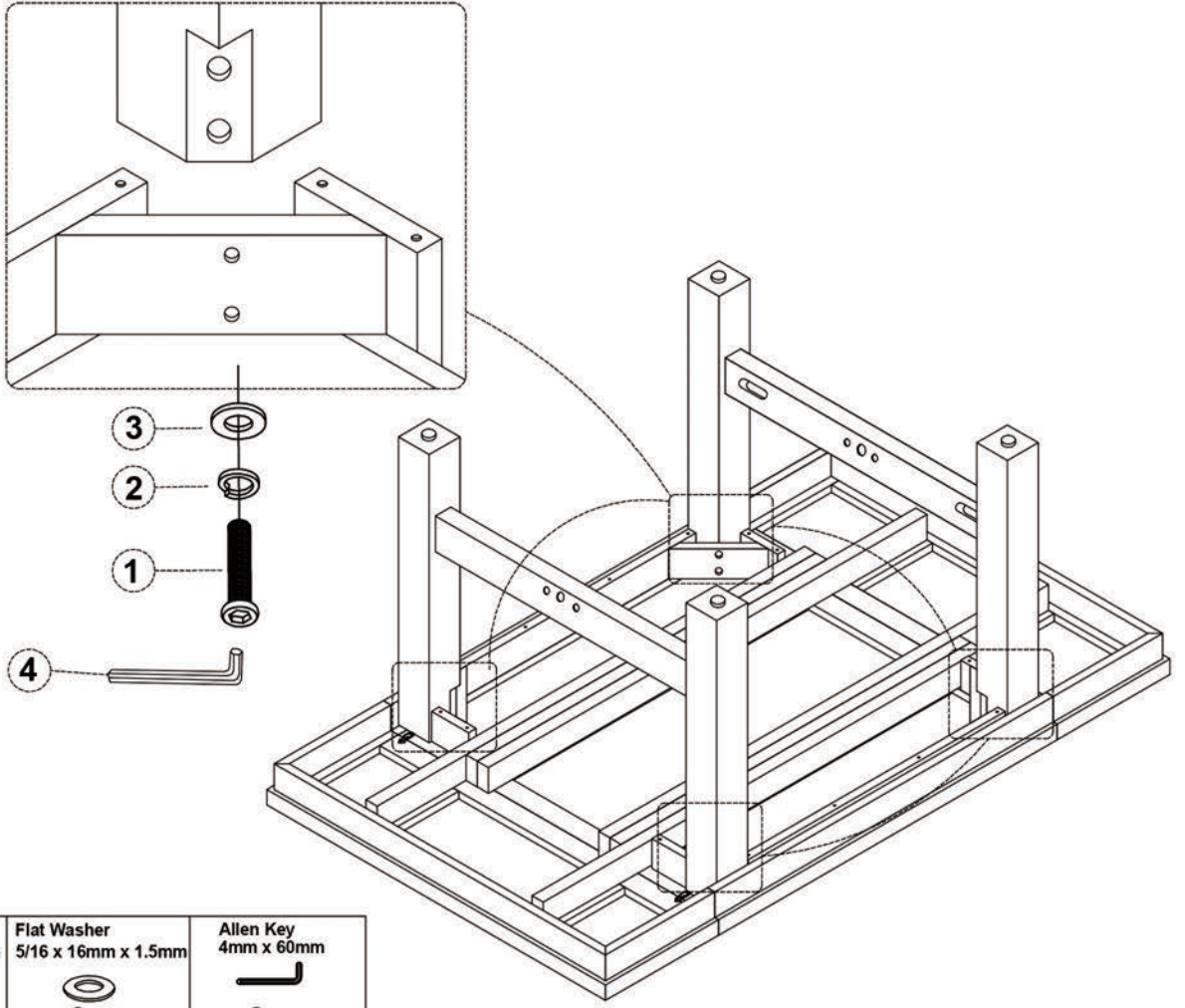

Bolts 5/16 x 50mm  ① x 4	Spring Washer 5/16 x 13mm x 1.5mm  ② x 4	Flat Washer 5/16 x 16mm x 1.5mm  ③ x 4	Allen Key 4mm x 60mm  ④ x 1
---	---	---	---

STEP 2



Bolts 5/16 x 50mm  ① x 8	Spring Washer 5/16 x 13mm x 1.5mm  ② x 8	Flat Washer 5/16 x 16mm x 1.5mm  ③ x 8	Allen Key 4mm x 60mm  ④ x 1
--	---	---	--

STEP 3

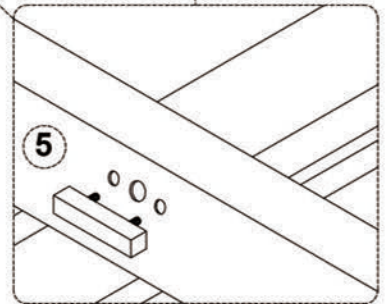
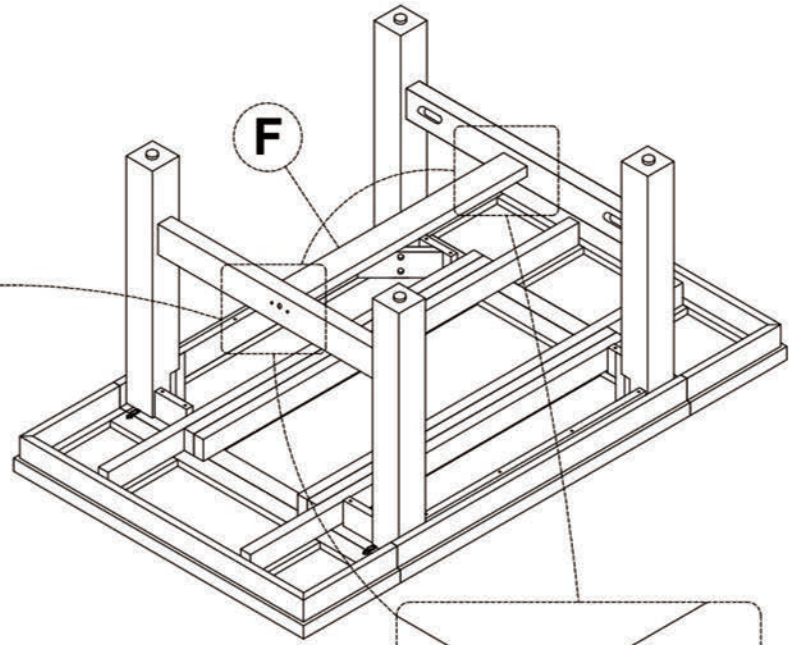
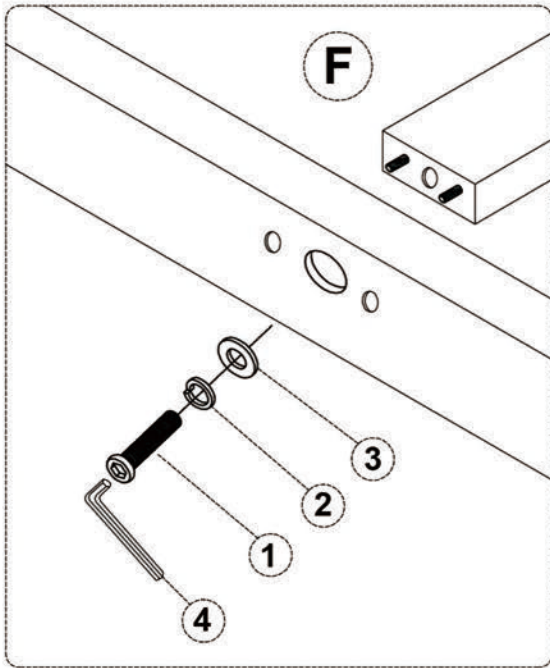

Bolts
5/16 x 50mm



① x 2

Spring Washer
5/16 x 13mm x 1.5mm



② x 2

Flat Washer
5/16 x 16mm x 1.5mm



③ x 2

Allen Key
4mm x 60mm



④ x 1

Ornament



⑤ x 2

FINISH

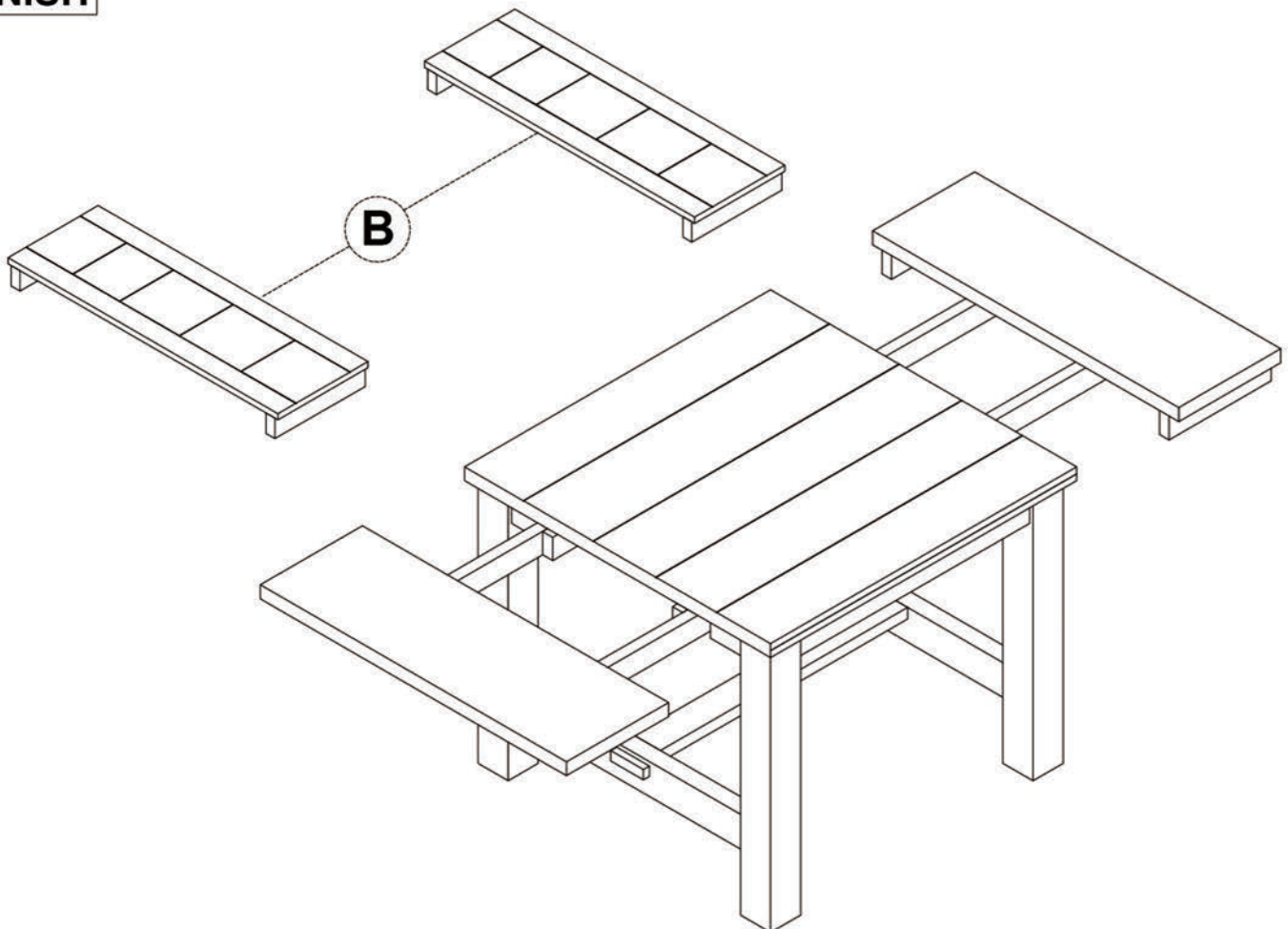

ASSEMBLY INSTRUCCIONES

ITEM NOTE : WF310633
DINING CHAIR

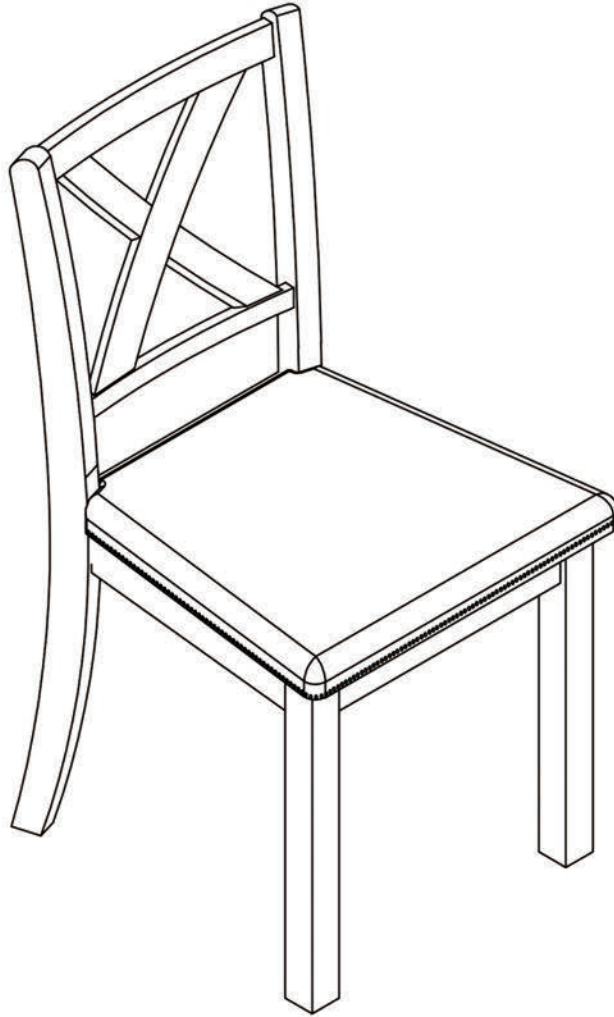





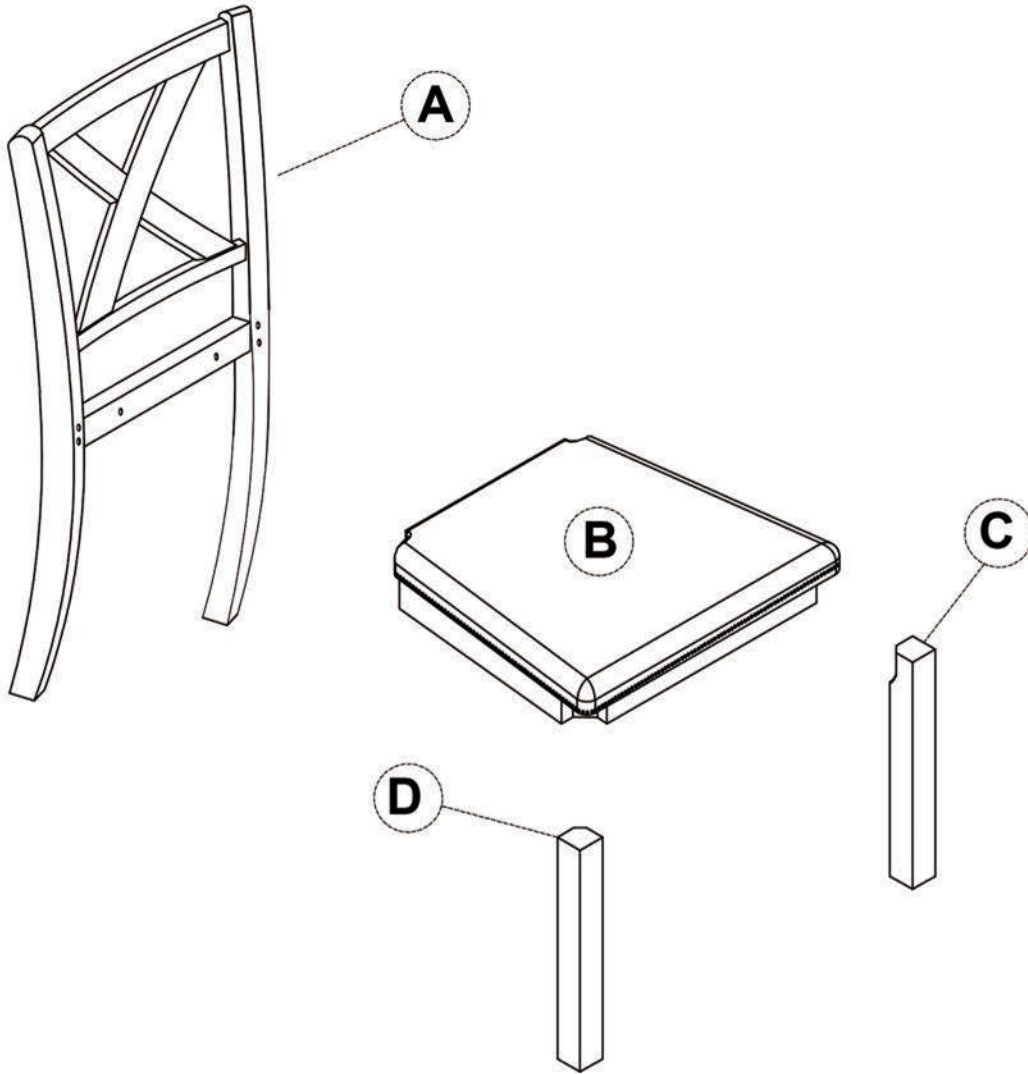

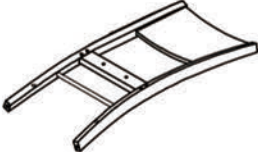

IMPORTANT NOTE:

- ① PLACE ALL PARTS ON A CLEAN AND SMOOTH SURFACE SUCH AS A RUG OR CARPET TO AVOID THE PARTS FROM BEING SCRATCHED.
- ② BEFORE YOU BEGIN, KINDLY FOLLOW THE ASSEMBLY INSTRUCTIONS STEP BY STEP.
- ③ DO NOT TIGHEN ALL SCREWS AND BOLTS UNTIL THE CHAIR IS FULLY STEP-UP







Part List For One

Hardware List For One

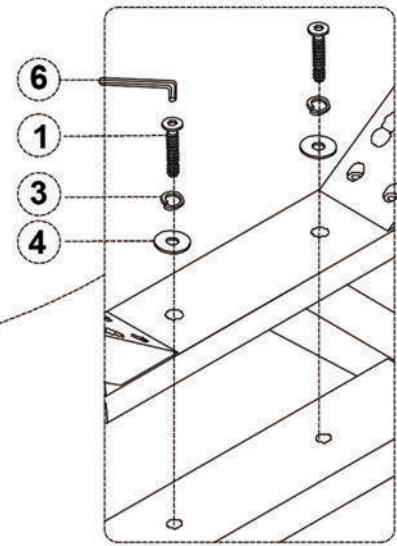
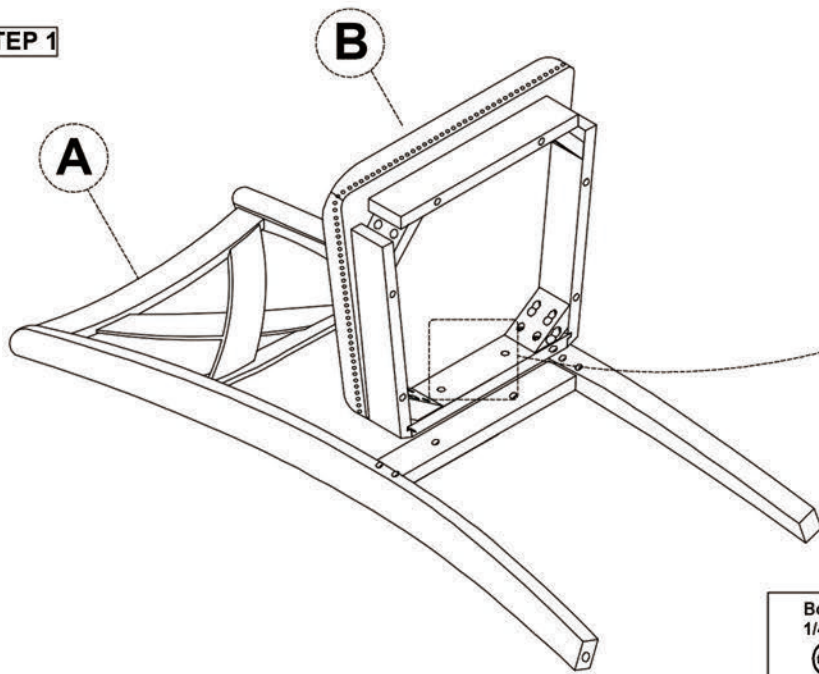
No	Parts Desc.	Q'ty	No	Hardware Desc.	Q'ty
A	BACK FRAME 	1pcs	1	Bolts 1/4" x 35mm 	2pcs
			2	Bolts 1/4" x 75mm 	4pcs
B	SEAT FRAME 	1pcs	3	Spring Washer 1/4" x 13mm x 1.5mm 	10pcs
			4	Flat Washer 1/4" x 16mm x 1.5mm 	10pcs
C	FRONT LEGS 	2pcs	5	Bolts 1/4" x 50mm 	4pcs
			6	Allen Key 4mm x 60mm 	1pcs

STEP 1



Bolts 1/4" x 35mm  ① x 2	Spring Washer 1/4" x 13mm x 1.5mm  ③ x 2	Flat Washer 1/4" x 16mm x 1.5mm  ④ x 2	Allen Key 4mm x 60mm  ⑥ x 1
---	---	---	--



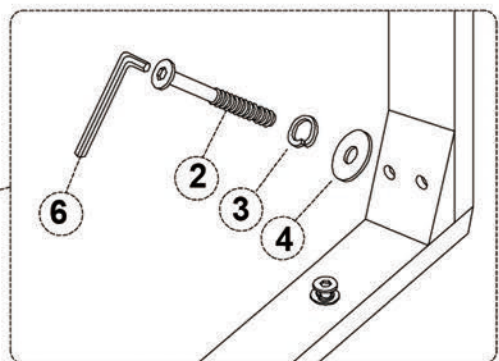
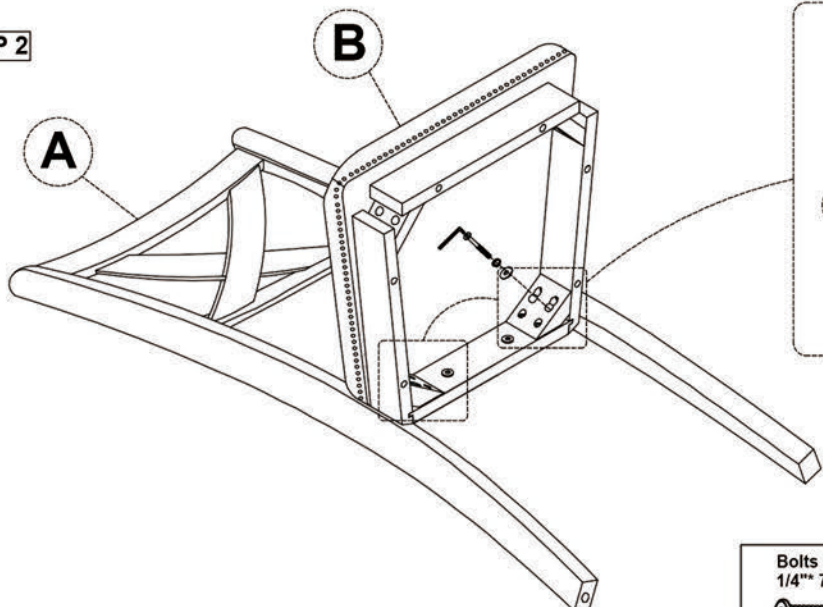

STEP 2

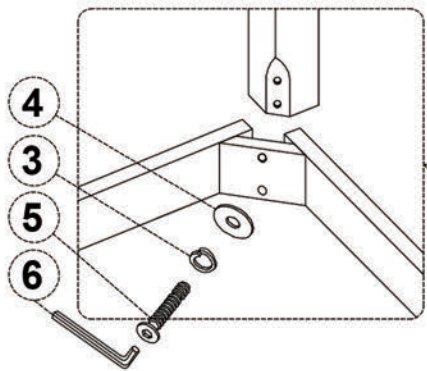
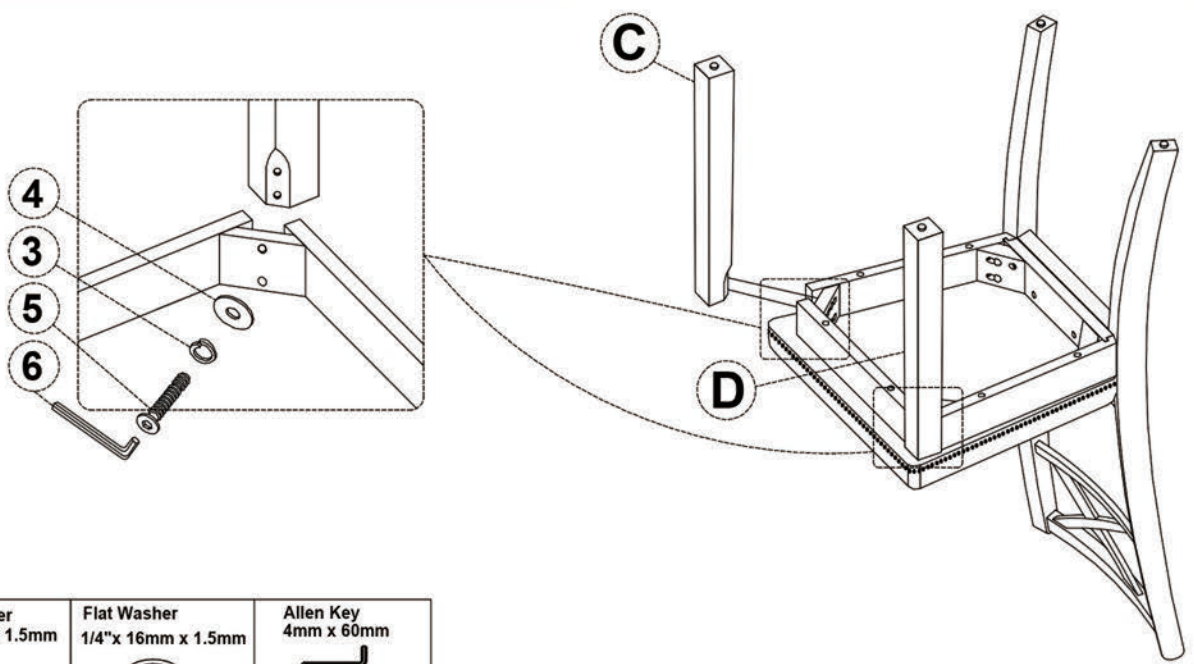

Bolts 1/4" x 75mm  ② x 4	Spring Washer 1/4" x 13mm x 1.5mm  ③ x 4	Flat Washer 1/4" x 16mm x 1.5mm  ④ x 4	Allen Key 4mm x 60mm  ⑥ x 1
---	---	---	--

STEP 3



Bolts 1/4" x 50mm  ⑤ x 4	Spring Washer 1/4" x 13mm x 1.5mm  ③ x 4	Flat Washer 1/4" x 16mm x 1.5mm  ④ x 4	Allen Key 4mm x 60mm  ⑥ x 1
--	---	---	--

ASSEMBLY INSTRUCCIONES

ITEM NOTE : WF310634

BENCH

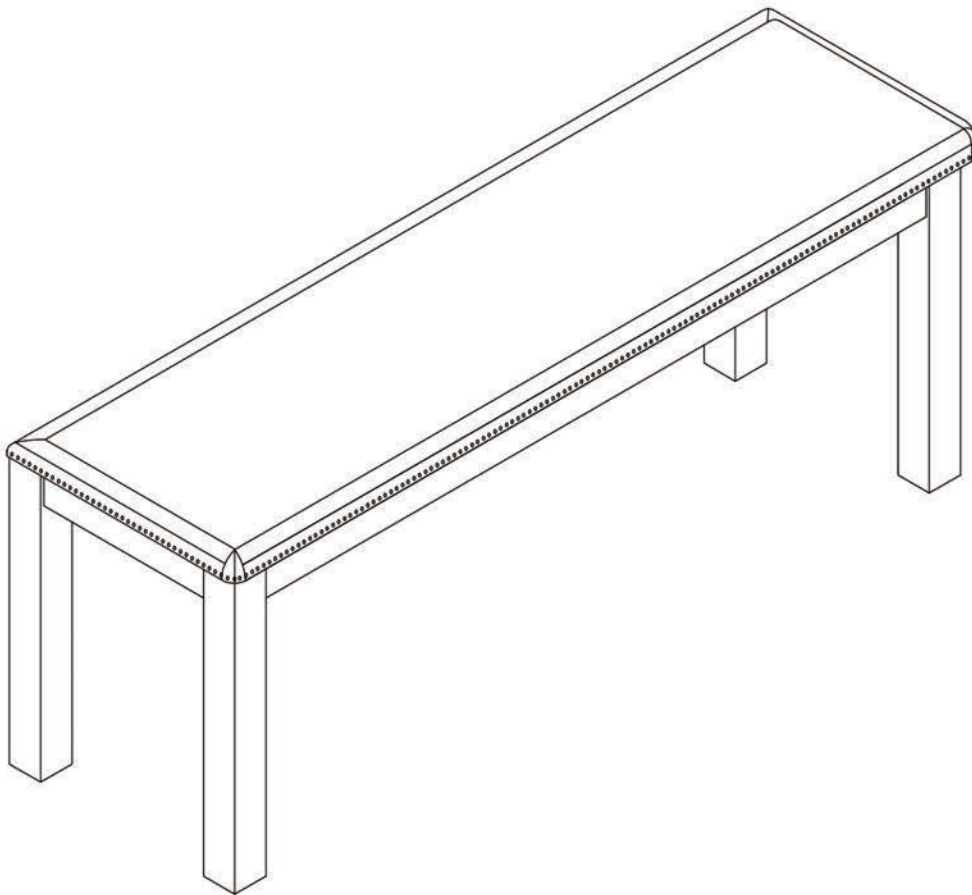





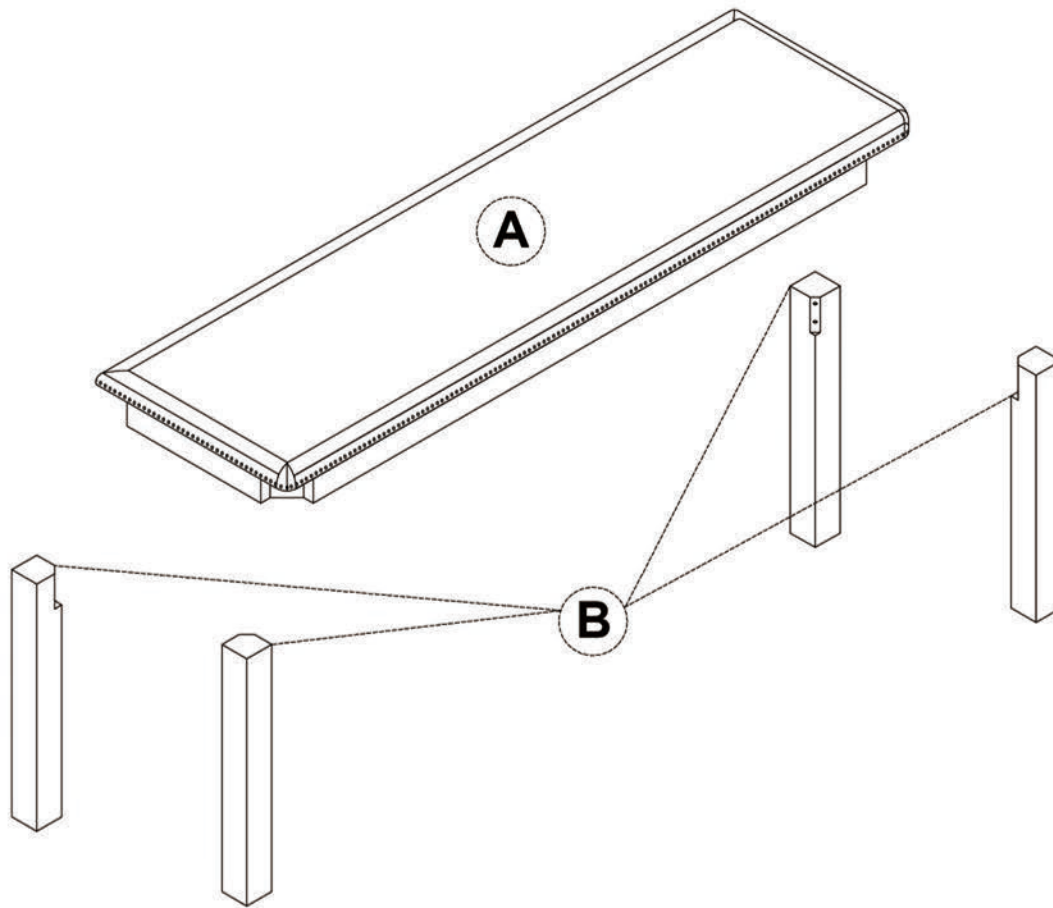

IMPORTANT NOTE:

- ① PLACE ALL PARTS ON A CLEAN AND SMOOTH SURFACE SUCH AS A RUG OR CARPET TO AVOID THE PARTS FROM BEING SCRATCHED.
- ② BEFORE YOU BEGIN, KINDLY FOLLOW THE ASSEMBLY INSTRUCTIONS STEP BY STEP.
- ③ DO NOT TIGHEN ALL SCREWS AND BOLTS UNTIL THE BENCH IS FULLY STEP-UP



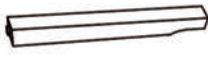

Part List For One

Hardware List For One

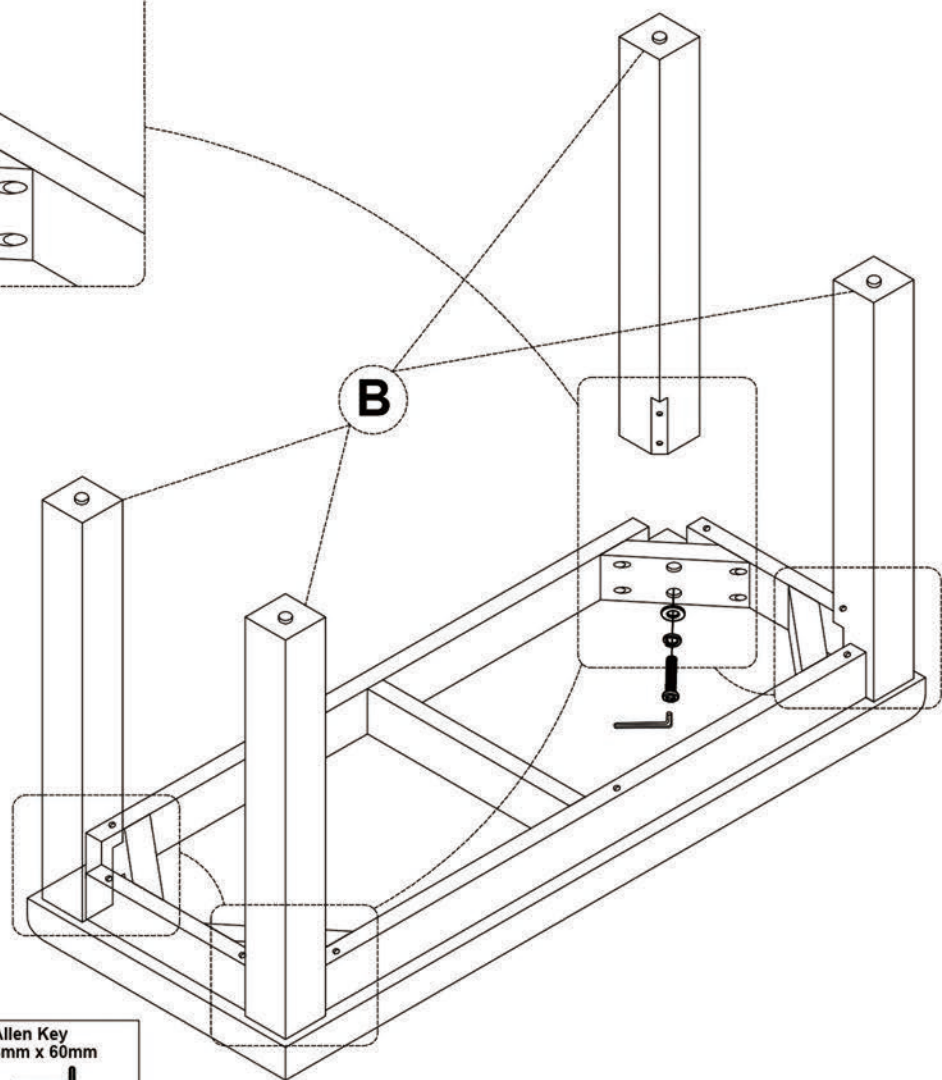
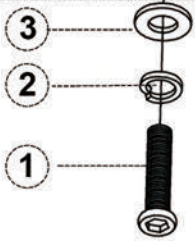
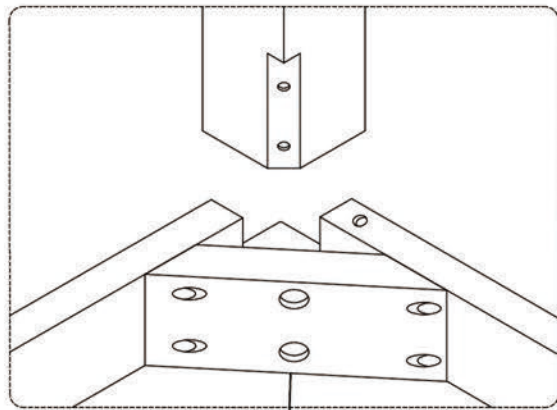
No	Parts Desc.	Q'ty	No	Hardware Desc.	Q'ty
A	SEAT FRAME 	1pcs	1	Bolts 1/4" x 50mm 	8pcs
			2	Spring Washer 1/4" x 13mm x 1.5mm 	8pcs
			3	Flat Washer 1/4" x 16mm x 1.5mm 	8pcs
B	LEGS 	4pcs	4	Allen Key 4mm x 60mm 	1pcs

STEP 1

Bolts 1/4" x 50mm  ① x 8	Spring Washer 1/4" x 13mm x 1.5mm  ② x 8	Flat Washer 1/4" x 16mm x 1.5mm  ③ x 8	Allen Key 4mm x 60mm  ④ x 1
--	---	---	--

FINISH