

ASSEMBLY INSTRUCTION

ITEM NO.WF322910

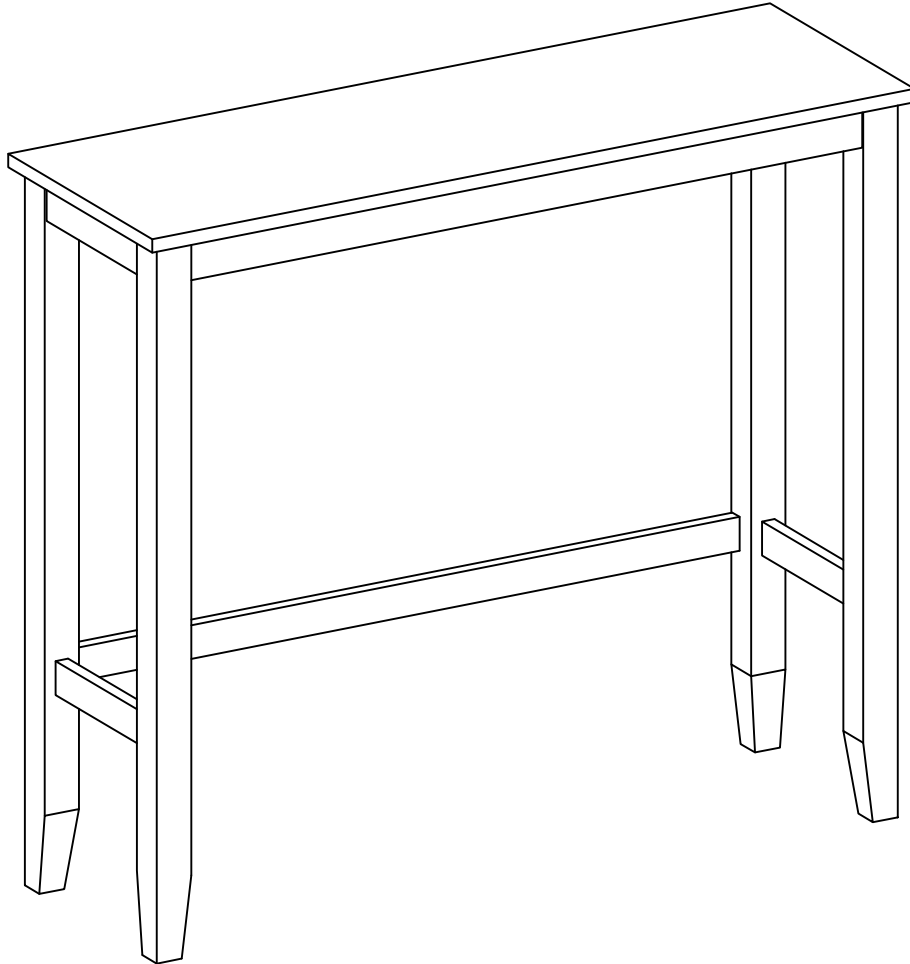

IMPORTANT NOTE :

- ① PLACE ALL PARTS ON A CLEAN AND SMOOTH SURFACE SUCH AS A RUG OR CARPET TO AVOID THE PARTS FROM BEING SCRATCHED.
- ② BEFORE YOU BEGIN, KINDLY FOLLOW THE SEEMBLY INSTRUCTIONS STEP BY STEP.
- ③ DO NOT TIGTEN ALL SCREWS AND BOLTS UNTIL THE TABLE IS FULLY SET-UP.

ASSEMBLY INSTRUCTION

ITEM NO.WF322910

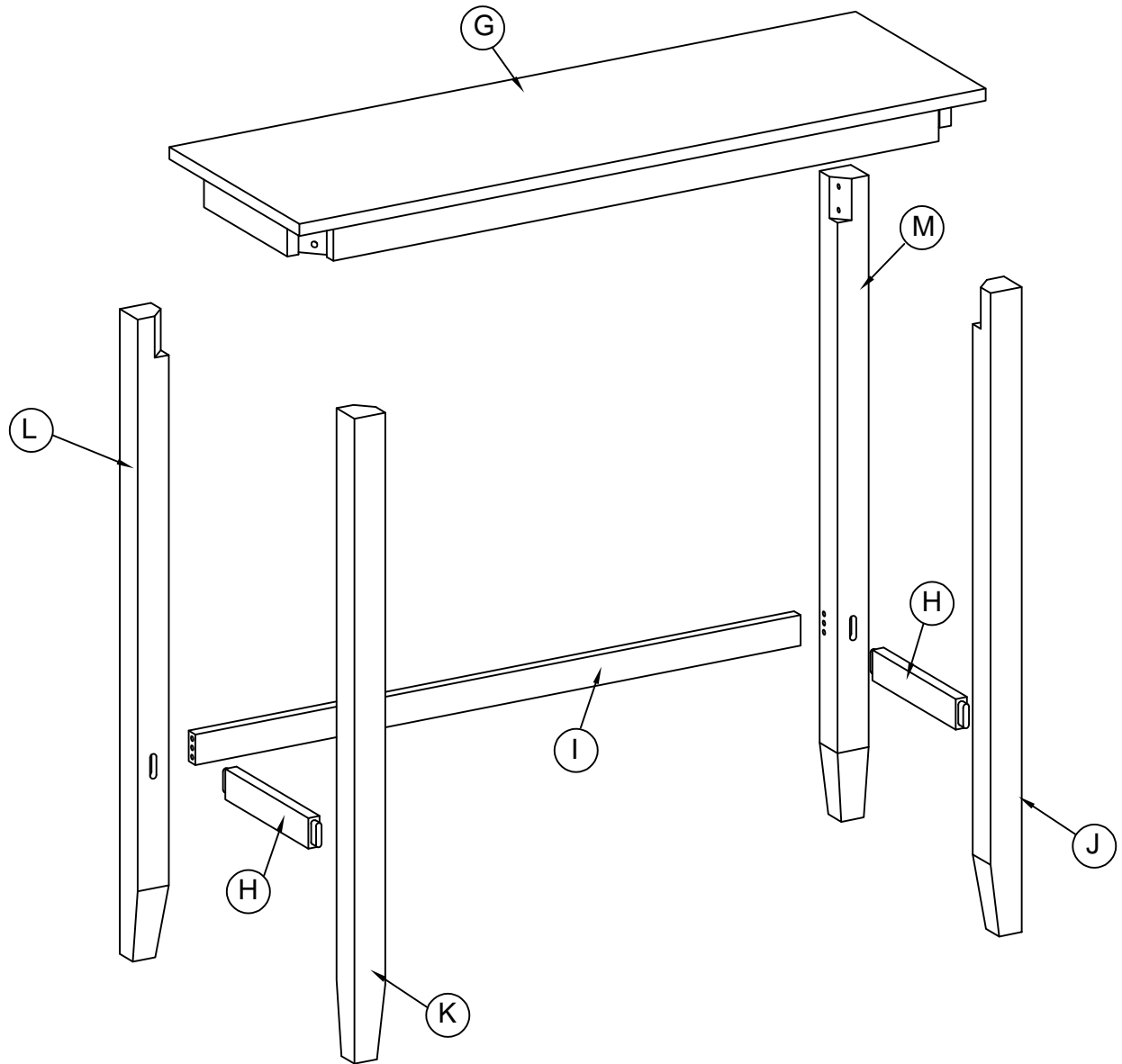

ASSEMBLY INSTRUCTION

ITEM NO.WF322910

PARTS LIST:

Table Top (1pc)	Side stretcher (2pcs)	Back stretcher (1pc)	
Front right leg (1pc)	Front left leg (1pc)	Back left leg (1pc)	Back right leg (1pc)

HARDWARE LIST:

M6*L50mm Bolt (10pcs)	8*L30mm Wood Dowel (4pcs)	4mm Allen Key (1pc)
M6 Haft Moon Washer (2pcs)	4*L44mm Wood Screw (4pcs)	Asembly tools required (not included)

ASSEMBLY INSTRUCTION

ITEM NO.WF322910

STEP 1:

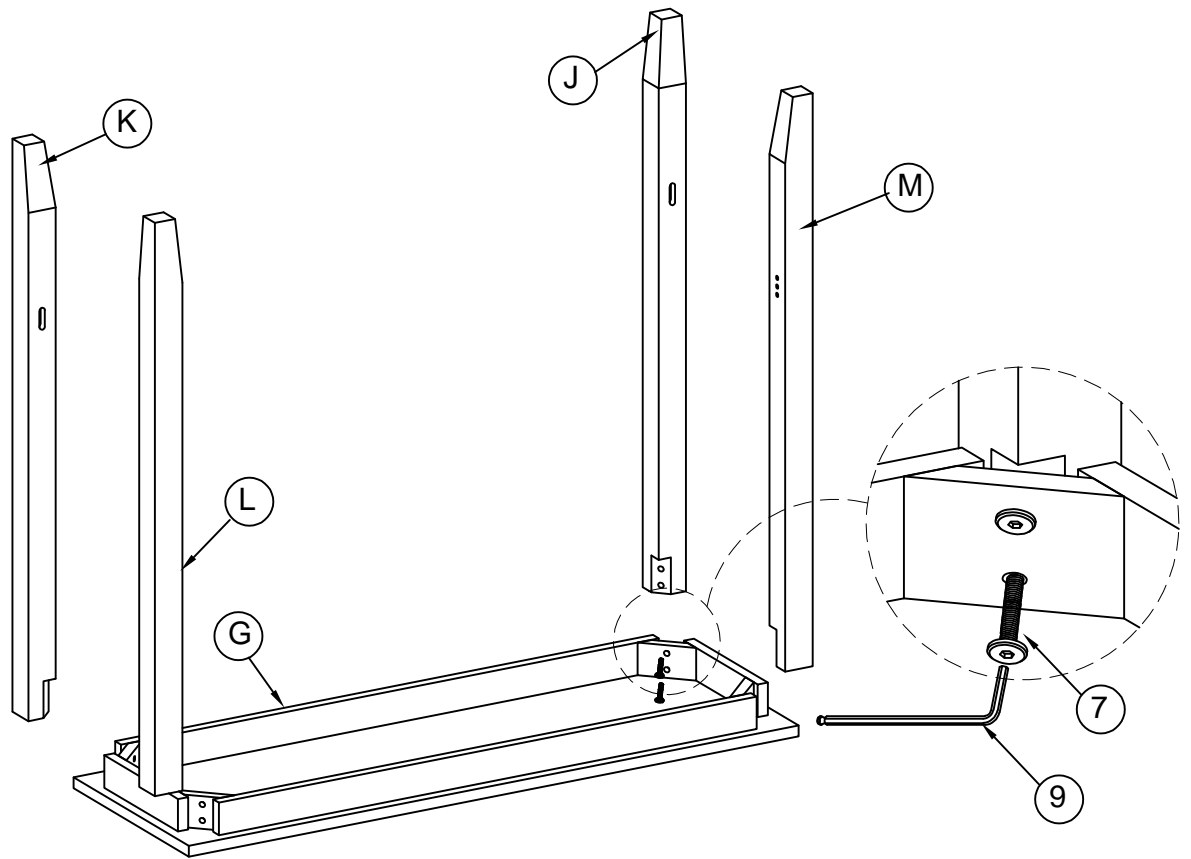

STEP 2:

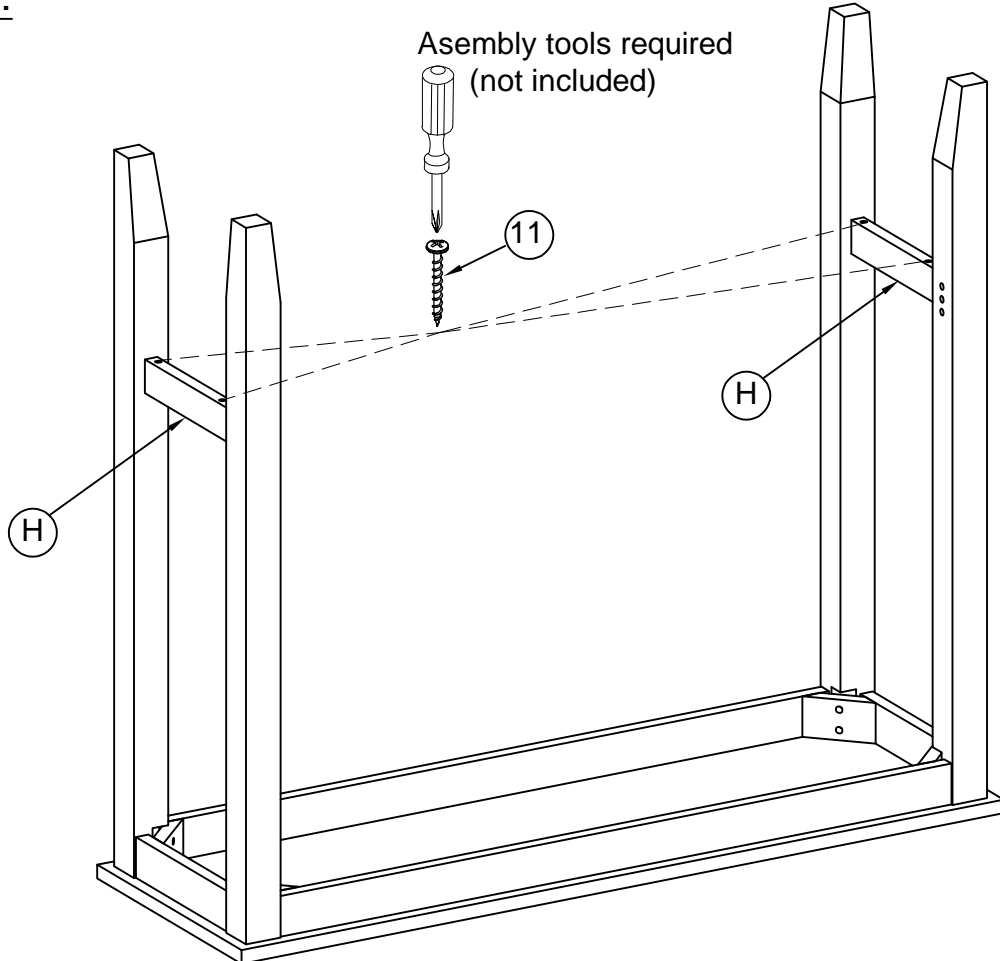

ASSEMBLY INSTRUCTION

ITEM NO.WF322910

STEP 3:

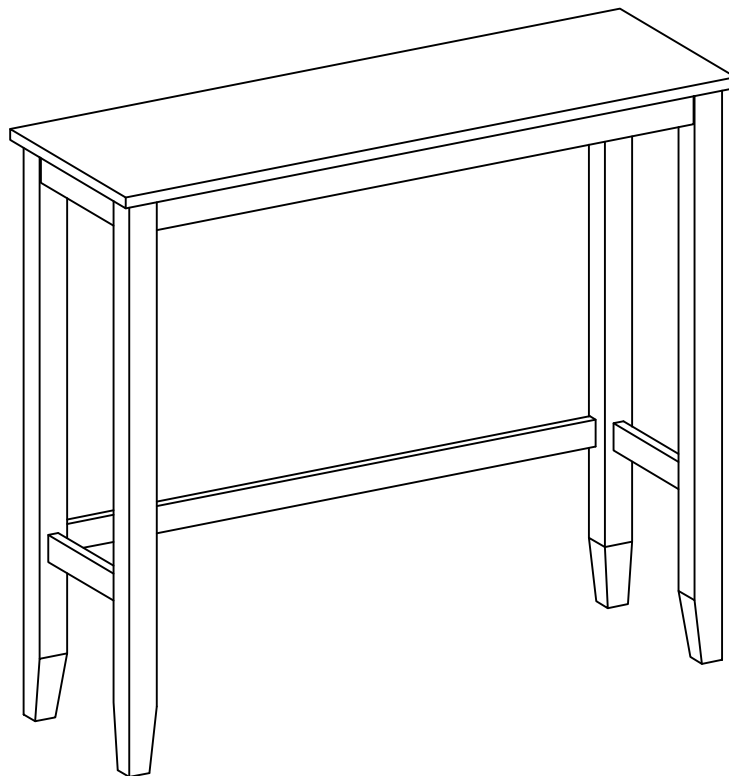
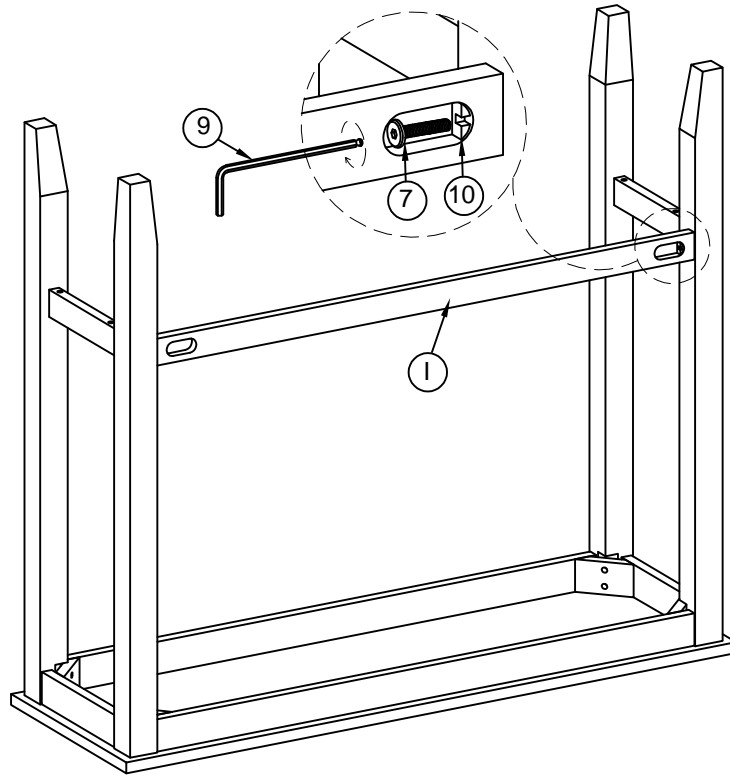

ASSEMBLY INSTRUCTION

ITEM NO.WF322910

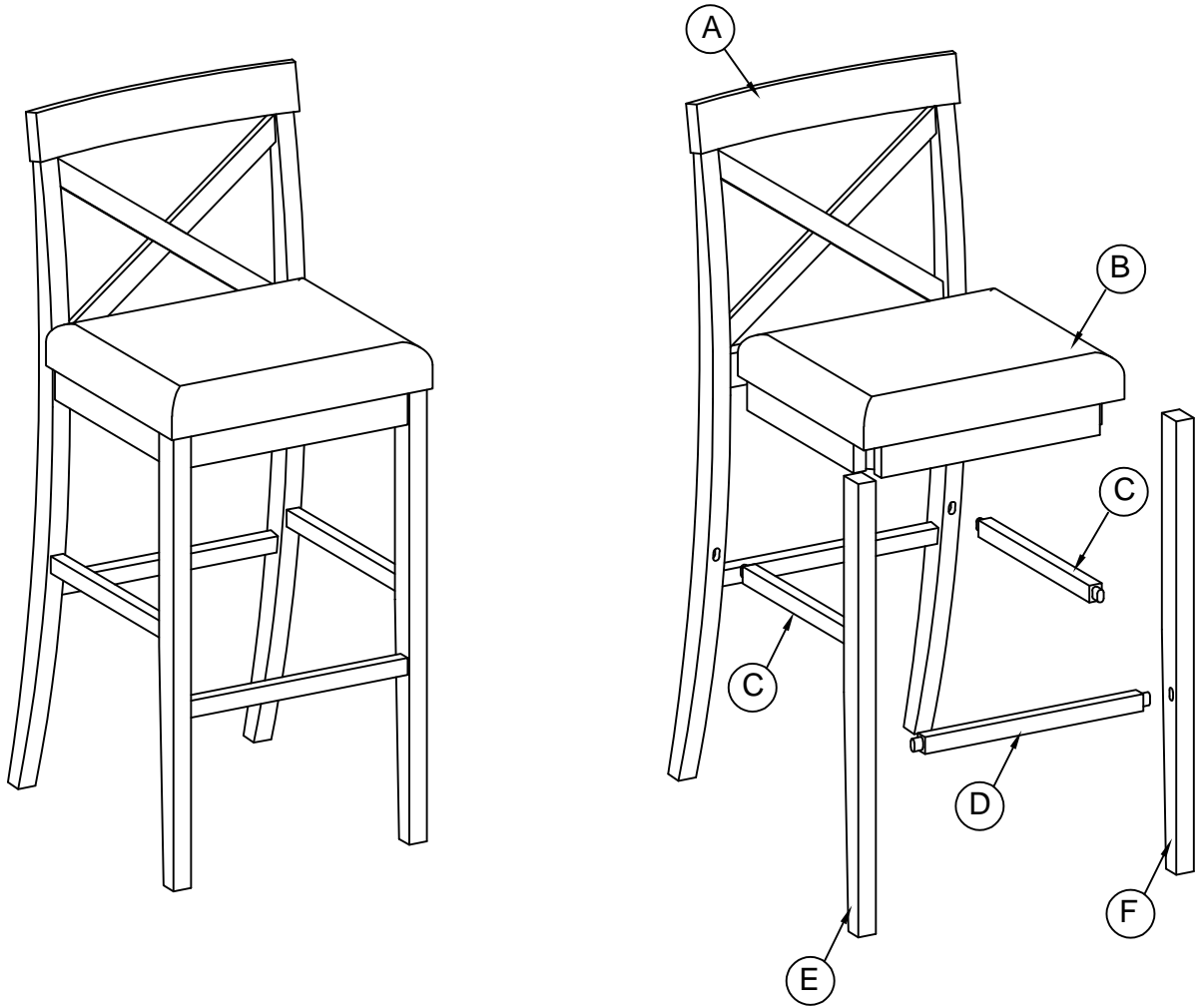





IMPORTANT NOTE :

- ① PLACE ALL PARTS ON A CLEAN AND SMOOTH SURFACE SUCH AS A RUG OR CARPET TO AVOID THE PARTS FROM BEING SCRATCHED.
- ② BEFORE YOU BEGIN, KINDLY FOLLOW THE SEEMBLY INSTRUCTIONS STEP BY STEP.
- ③ DO NOT TIGTEN ALL SCREWS AND BOLTS UNTIL THE CHAIRS IS FULLY SET-UP.

ASSEMBLY INSTRUCTION

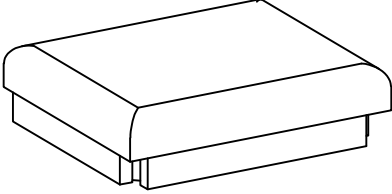
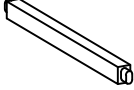
ITEM NO.WF322910

PARTS LIST:

		
<p>Chair Back (2pcs)</p>	<p>Chair Seat (2pcs)</p>	<p>Side strecher (4pcs)</p>
		
<p>Front Strecher (2pcs)</p>	<p>Left Leg (2pcs)</p>	<p>Right Leg (2pcs)</p>

HARDWARE LIST:

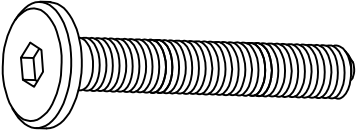
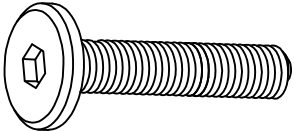
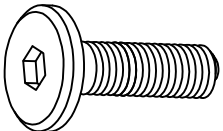
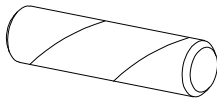
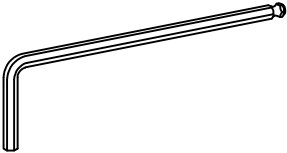
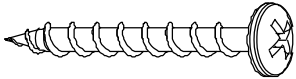
		
<p>M6*L70mm Bolt (8pcs)</p>	<p>M6*L50mm Bolt (8pcs)</p>	<p>M6*L35mm Bolt (2pcs)</p>
		
<p>8*L30mm Wood Dowel (4pcs)</p>	<p>4mm Allen Key (2pcs)</p>	<p>4*L44mm Wood Screw (12pcs)</p>

ASSEMBLY INSTRUCTION

ITEM NO.WF322910

STEP1:

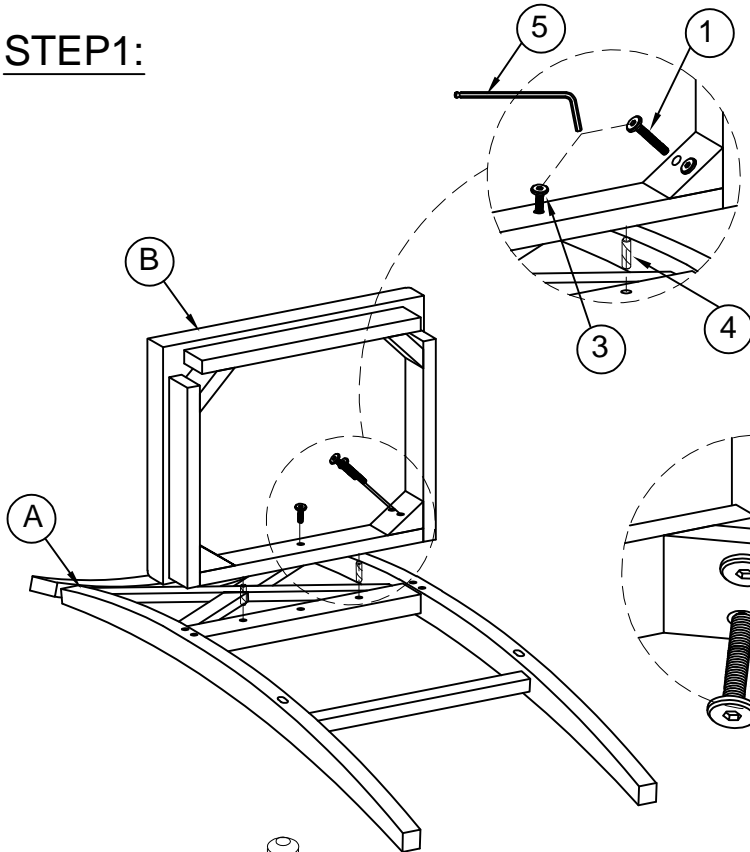

STEP2:

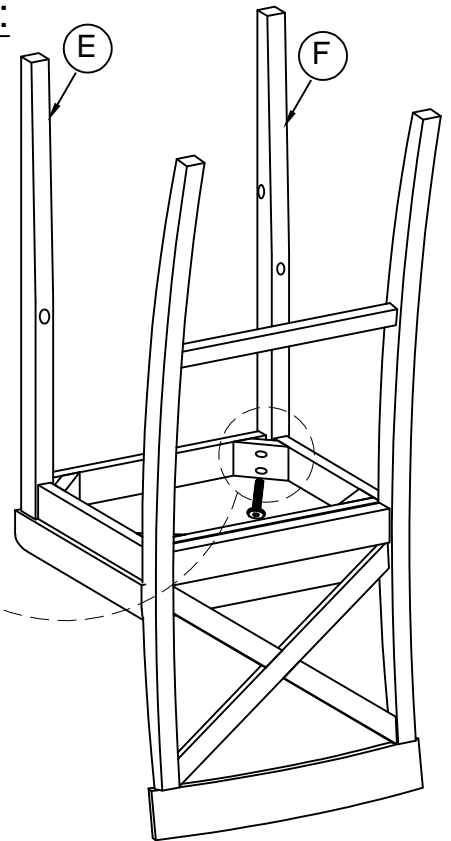

STEP3:

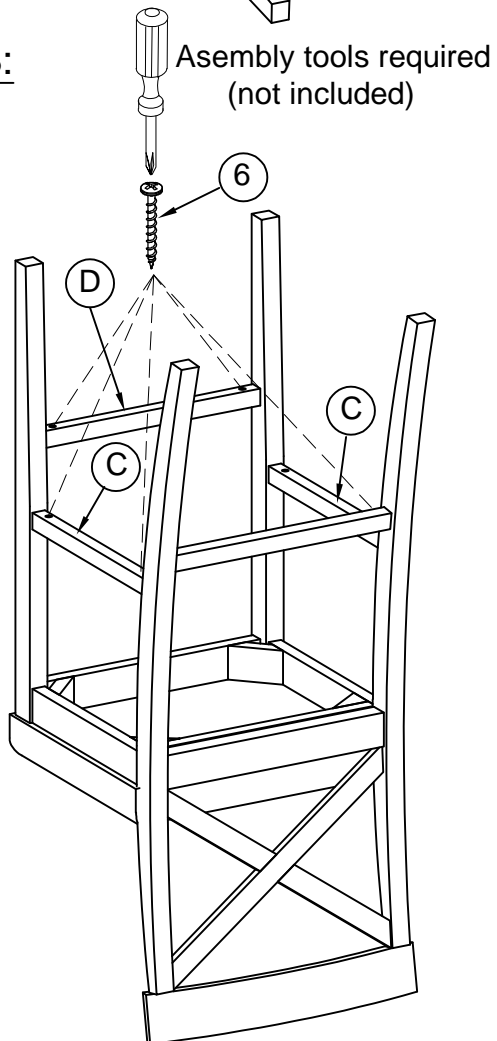

Assembly tools required
(not included)

