

# ASSEMBLY INSTRUCTIONS

## DINING TABLE

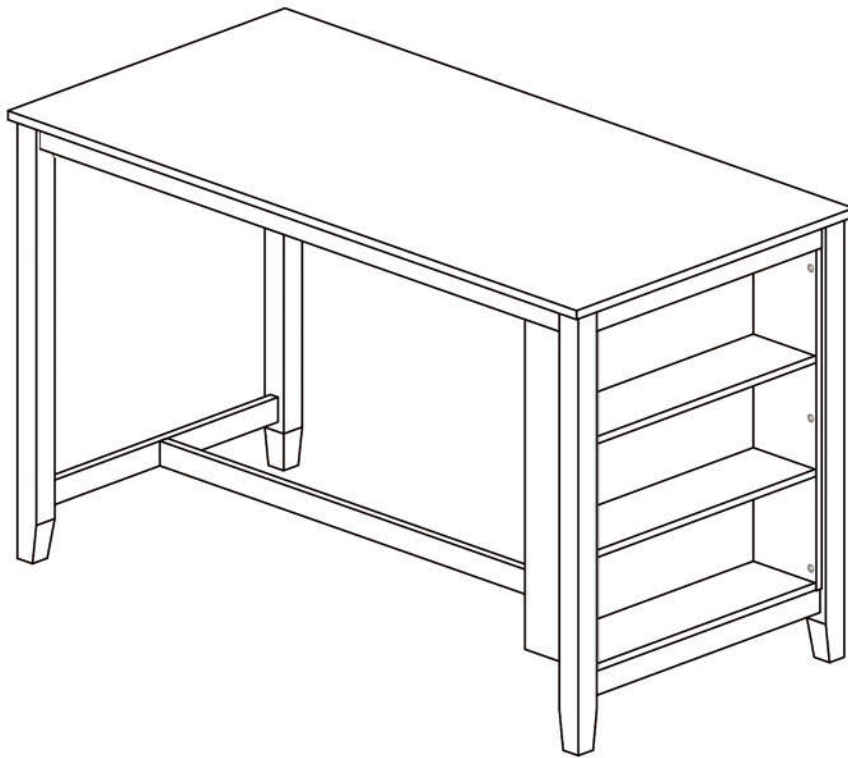

**WF318023**

### **IMPORTANT NOTE:**

- PLACE ALL PARTS ON A CLEAN AND SMOOTH SURFACE SUCH AS A RUG OR CARPET TO AVOID THE PARTS FROM BEING SCRATCHED.
- BEFORE YOU BEGIN, KINDLY FOLLOW THE ASSEMBLY INSTRUCTIONS STEP BY STEP.
- DO NOT TIGHTEN ALL SCREWS AND BOLTS UNTIL THE TABLE IS FULLY SET-UP.

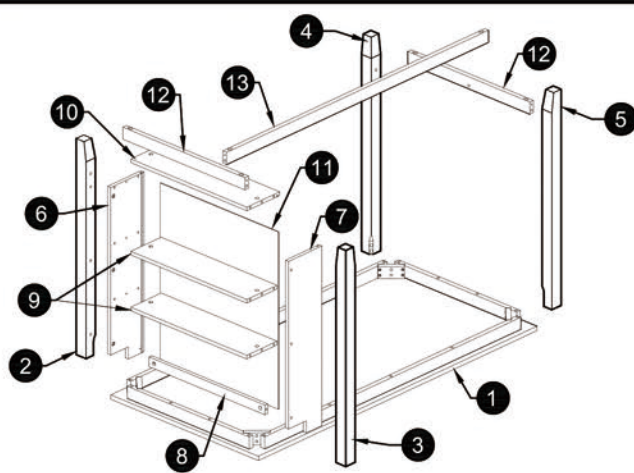

### CARTON CONTENT:

WF318023 :

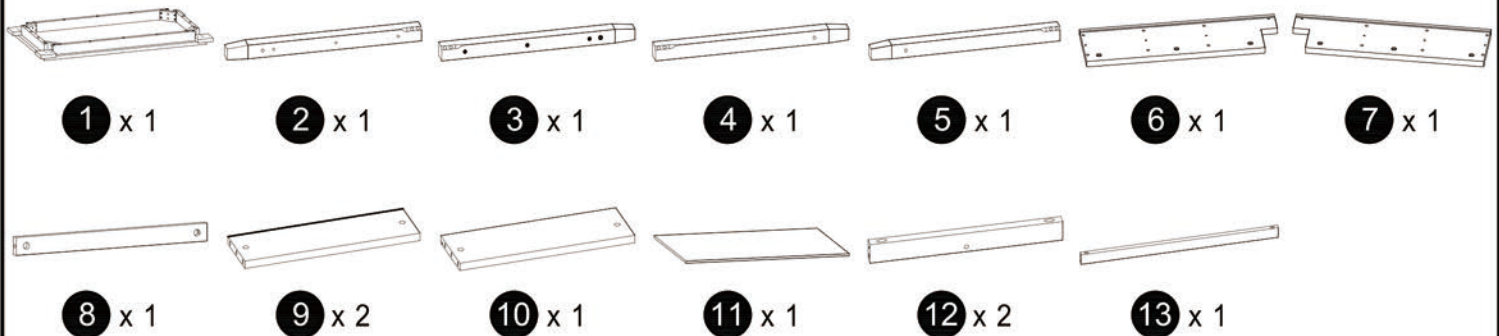

#### TABLE PART LISTS

NO.	DESCRIPTION	SKETCH	QTY
1	TABLE TOP		1 PC
2	TABLE LEG (R) (RACK SHELF)		1 PC
3	TABLE LEG (L) (RACK SHELF)		1 PC
4	TABLE LEG (R)		1 PC
5	TABLE LEG (L)		1 PC
6	RACK SIDE PANEL (R)		1 PC
7	RACK SIDE PANEL (L)		1 PC
8	RACK SUPPORT		1 PC
9	RACK SHELF MID		2 PCS
10	RACK SHELF BOTTOM		1 PC
11	RACK BACK PANEL		1 PC
12	SIDE BAR		2 PCS
13	MIDDLE BAR		1 PC

#### TABLE HARDWARE LISTS

NO.	DESCRIPTION	SKETCH	QTY
A	CAM LOCK		8 PCS
B	CAM BOLT		8 PCS
C	WOOD DOWEL M8 x 30mm		12 PCS
D	HEX COMB 5/16 x 2 1/2"		8 PCS
E	JCBC BOLT M6 x 35mm		6 PCS
F	SPRING WASHER 1/4"		6 PCS
G	SPANNER 12.8		1 PC
H	WOOD DOWEL M10 x 30mm		6 PCS
I	ALLEN KEY M4		1 PC
J	C/B SCREW M4 x 38mm		2 PCS
K	C/B SCREW M4 x 45mm		4 PCS
L	C/B SCREW M3.5 x 16mm		3 PCS
M	SPRING WASHER 5/16"		8 PCS
N	FLAT WASHER 5/16"		8 PCS

NOT INCLUDED

STEP 1

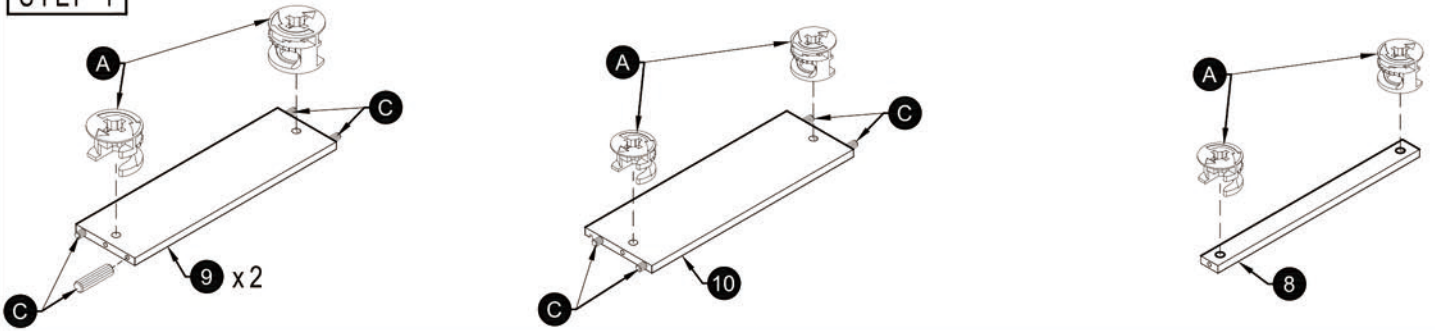

STEP 2

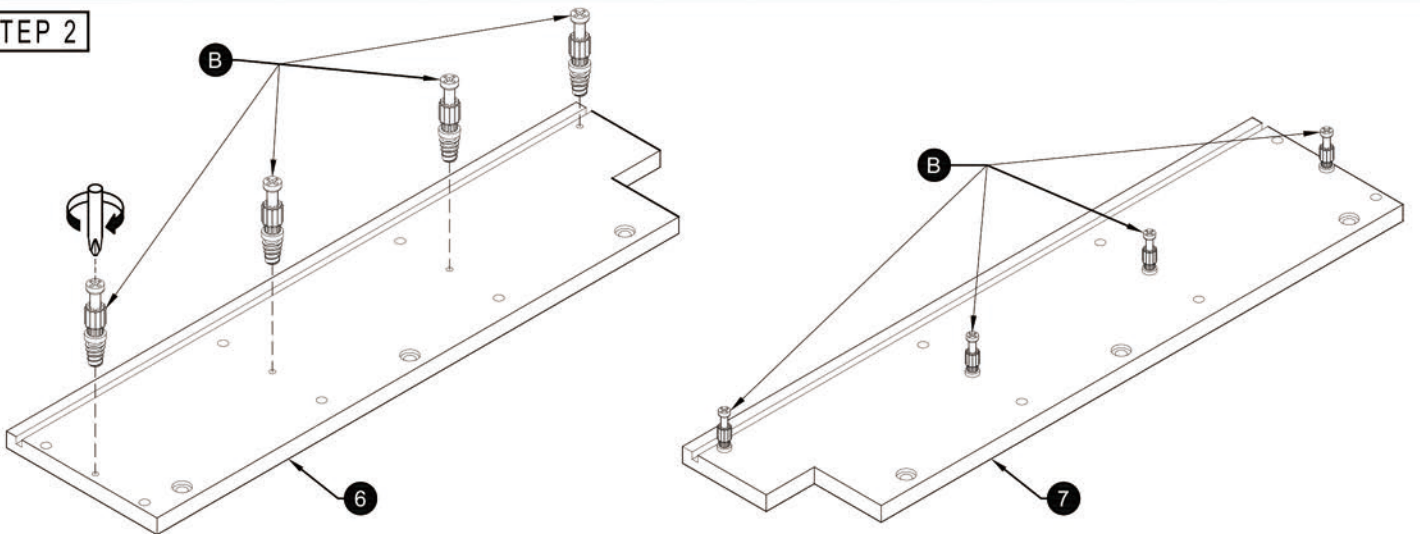

STEP 3

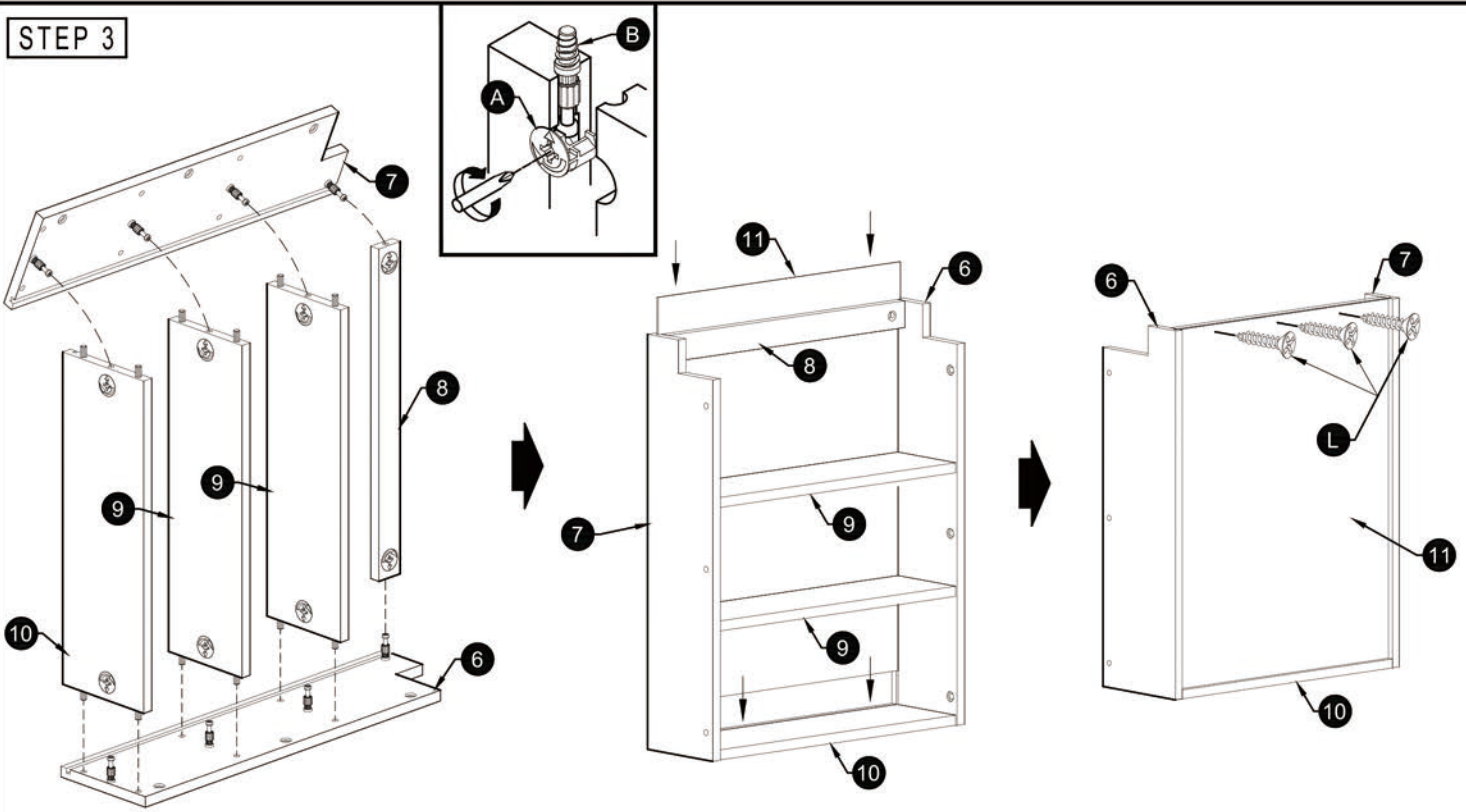

STEP 4

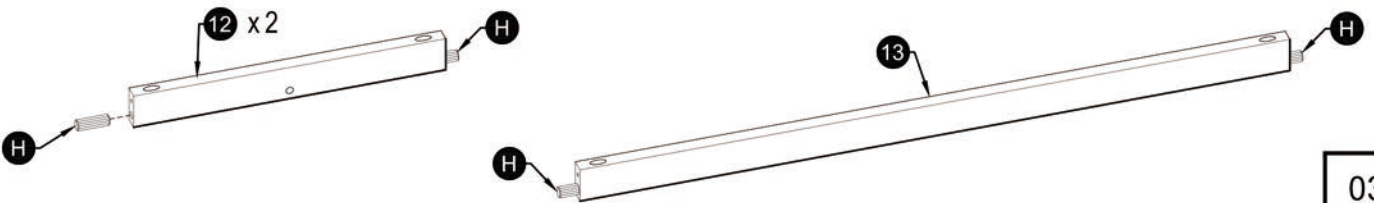

STEP 5

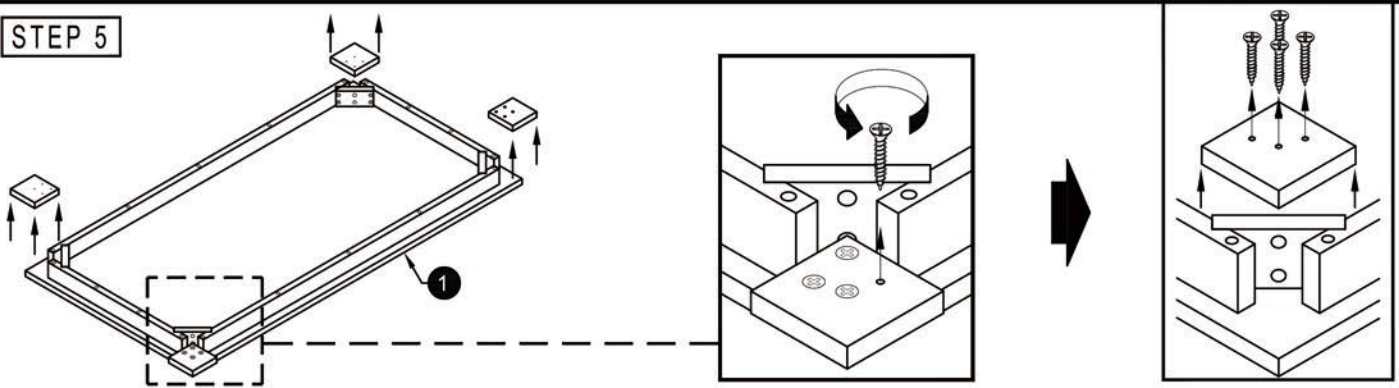

STEP 6

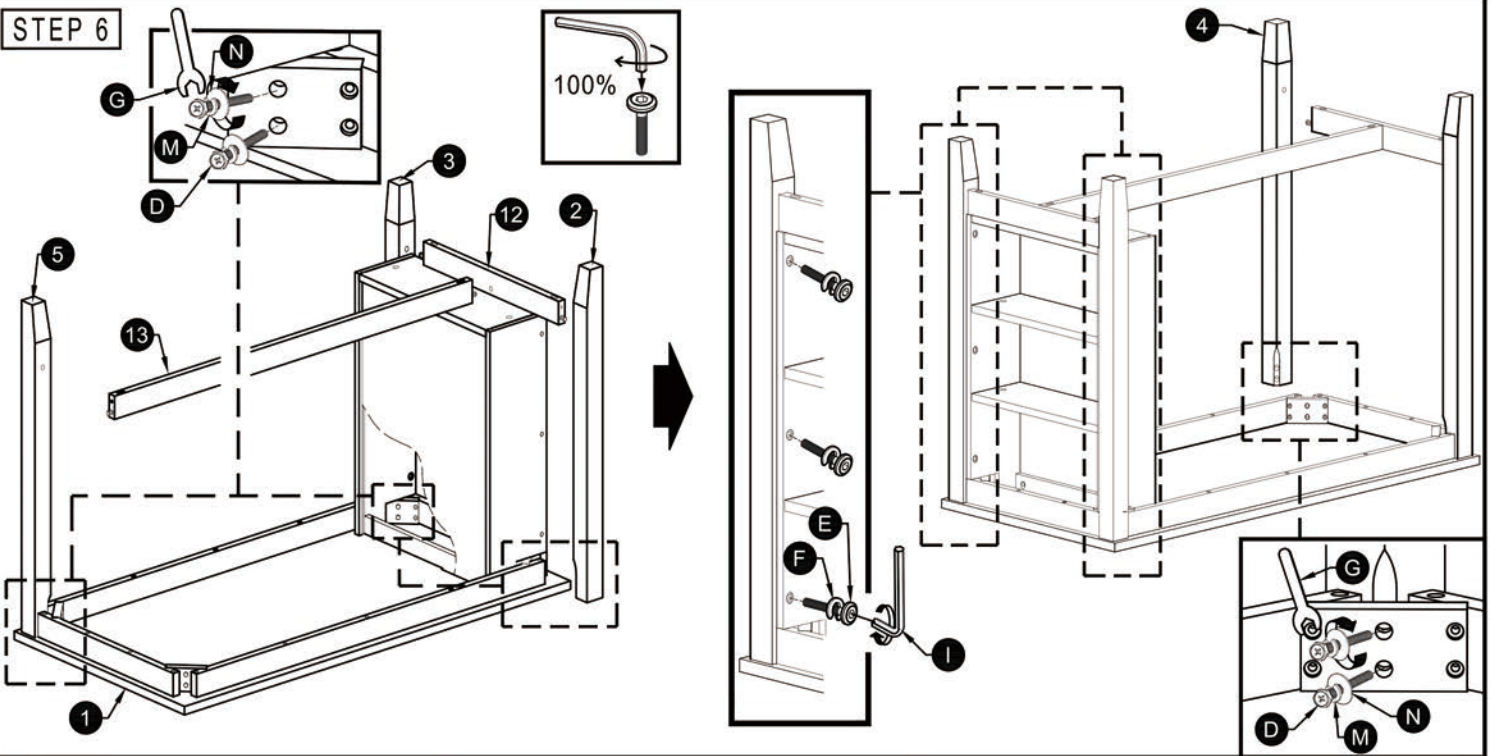

STEP 7

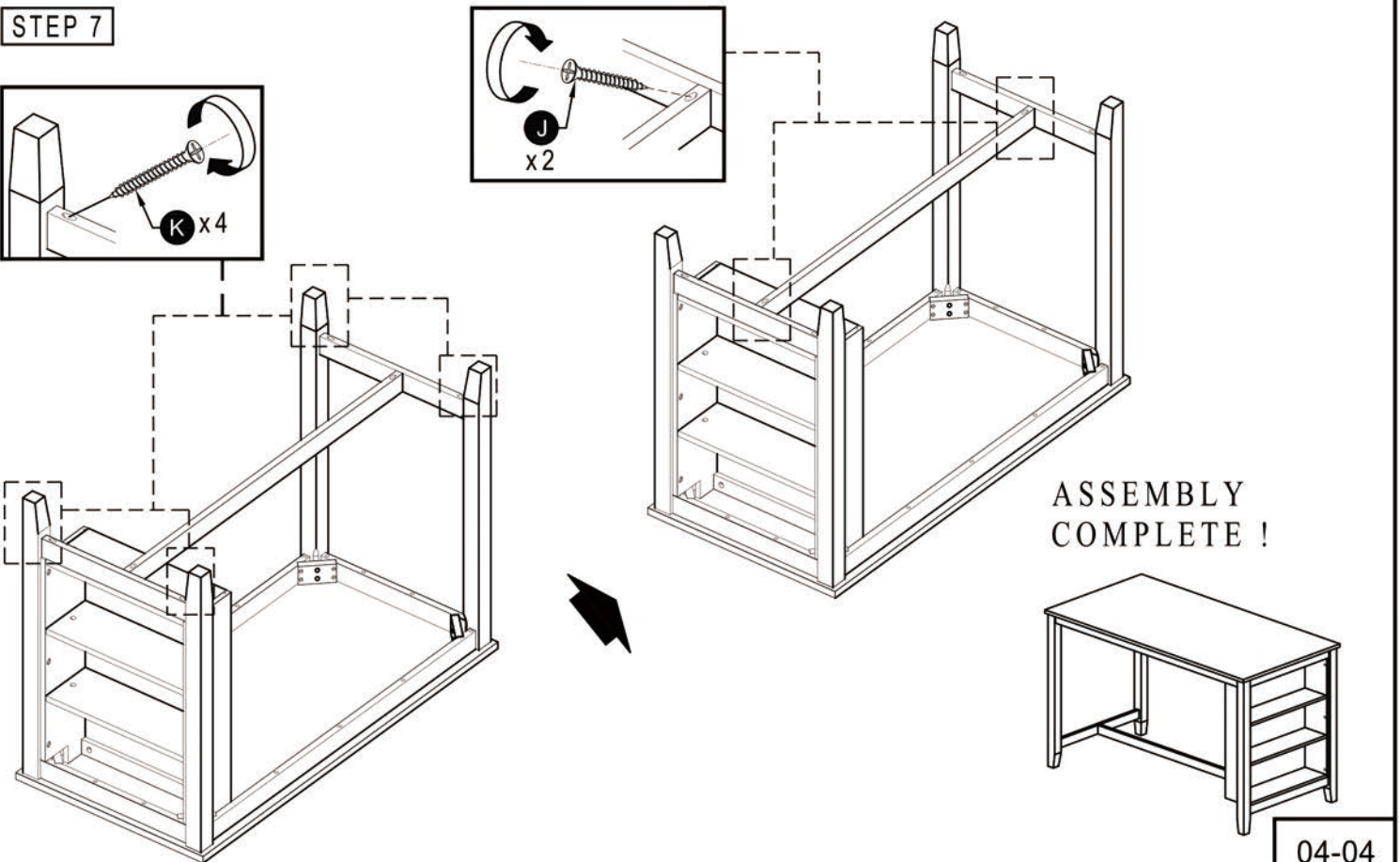

# ASSEMBLY INSTRUCTIONS

## DINING CHAIR

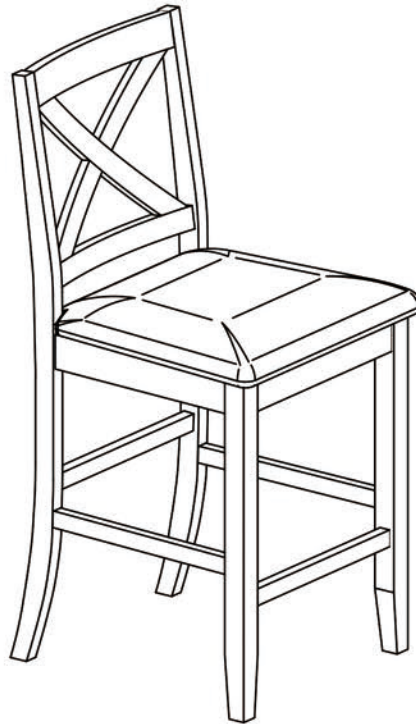

**WF318024**

### **IMPORTANT NOTE:**

- PLACE ALL PARTS ON A CLEAN AND SMOOTH SURFACE SUCH AS A RUG OR CARPET TO AVOID THE PARTS FROM BEING SCRATCHED.
- BEFORE YOU BEGIN, KINDLY FOLLOW THE ASSEMBLY INSTRUCTIONS STEP BY STEP.
- DO NOT TIGHTEN ALL SCREWS AND BOLTS UNTIL THE CHAIR IS FULLY SET-UP.

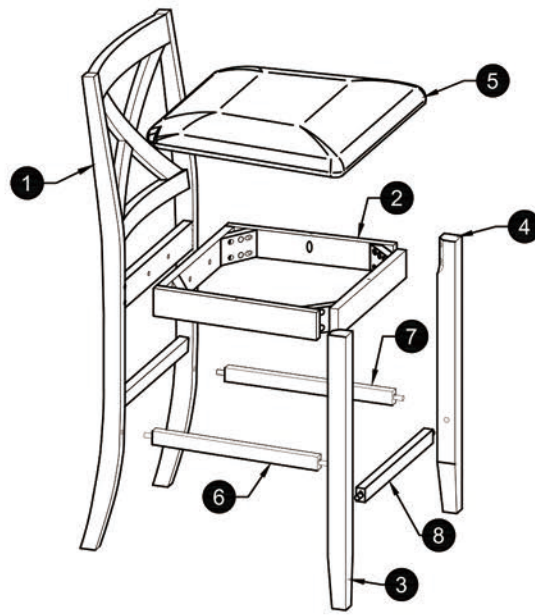

### CARTON CONTENT:

WF318024 :

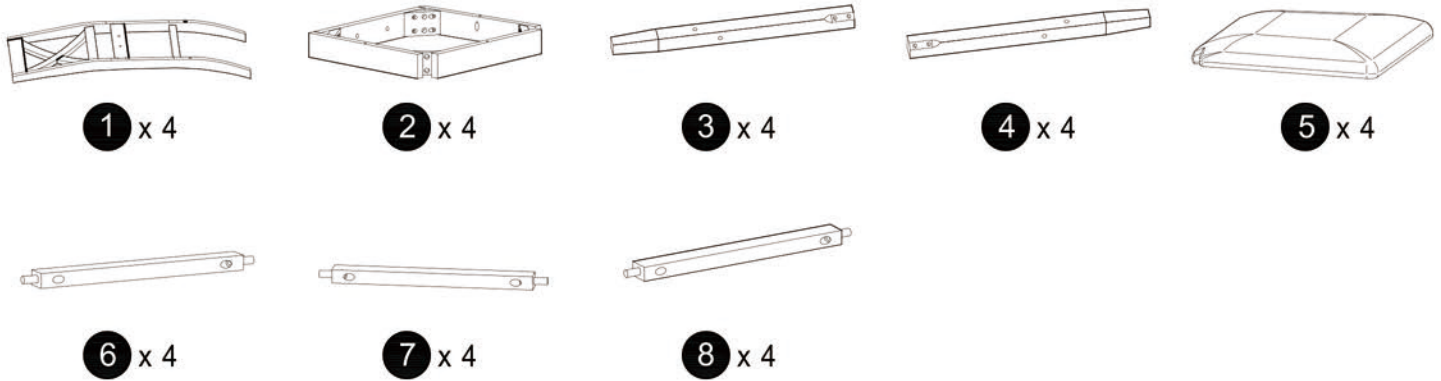

#### CHAIR PART LISTS

#### CHAIR HARDWARE LISTS

NO.	DESCRIPTION	SKETCH	QTY
1	BACK LEG		4 PCS
2	BOX SEAT		4 PCS
3	FRONT LEG ( L )		4 PCS
4	FRONT LEG ( R )		4 PCS
5	SEAT		4 PCS
6	STRETCHER ( L )		4 PCS
7	STRETCHER ( R )		4 PCS
8	STRETCHER ( F )		4 PCS

NO.	DESCRIPTION	SKETCH	QTY
A	JCBC BOLT M6 x 35mm		8 PCS
B	JCBC BOLT M6 x 60mm		16 PCS
C	JCBC BOLT M6 x 80mm		16 PCS
D	SPRING WASHER 1/4"		40 PCS
E	FLAT WASHER 1/4"		40 PCS
F	ALLEN KEY M4		1 PC
G	C/B SCREW M4 x 30mm		12 PCS
H	C/B SCREW M4 x 45mm		24 PCS

NOT INCLUDED

STEP 1

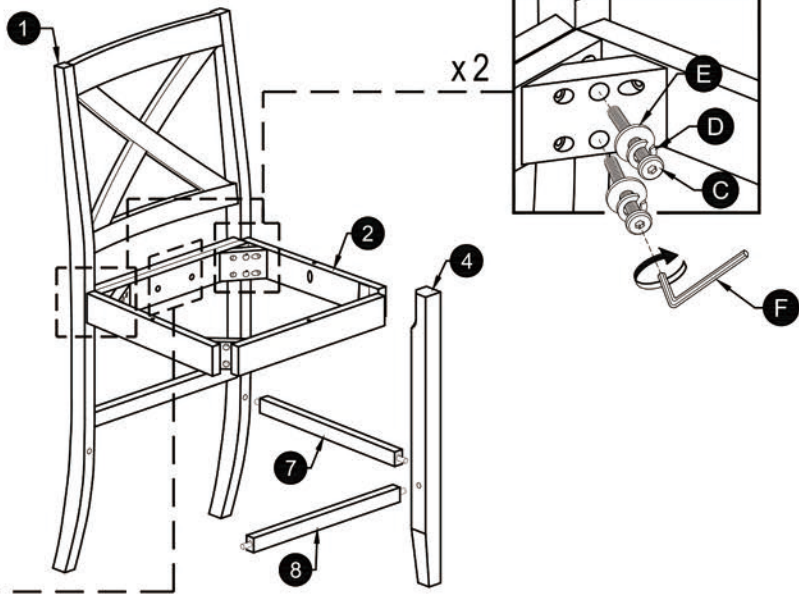

STEP 2

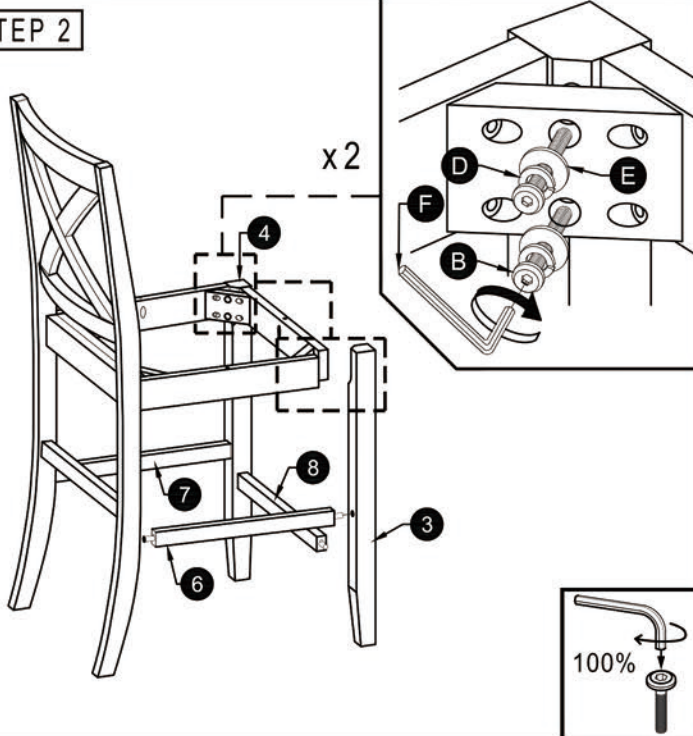

STEP 3

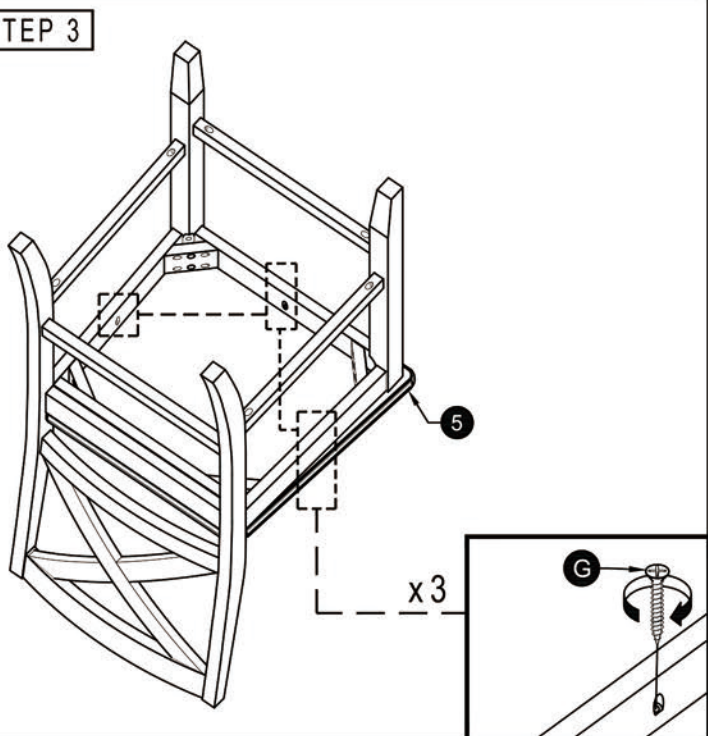

STEP 4

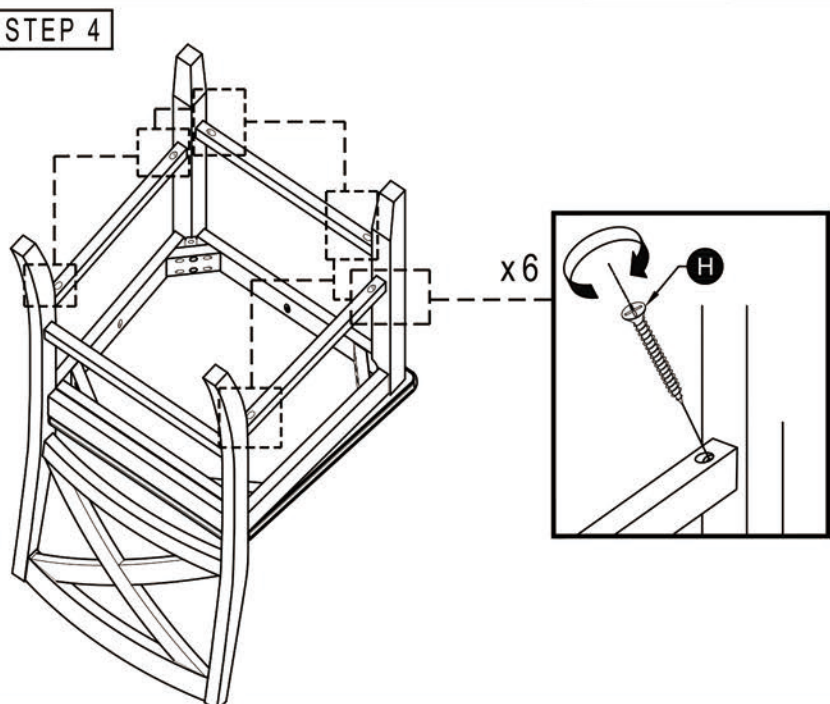

ASSEMBLY COMPLETE !

