

ASSEMBLY INSTRUCTION

WF322937- DINING TABLE

IMPORTANT NOTE :

** PLACE ALL PARTS ON A CLEAN AND SMOOTH SURFACE SUCH AS A RUG OR CARPET TO AVOID THE PARTS FROM BEING SCRATCHED.

** BEFORE YOU BEGIN, KINDLY FOLLOW THE ASSEMBLY INSTRUCTIONS STEP BY STEP.

**DO NOT TIGHTEN ALL SCREWS AND BOLTS UNTIL THE TABLE IS FULLY SET-UP.

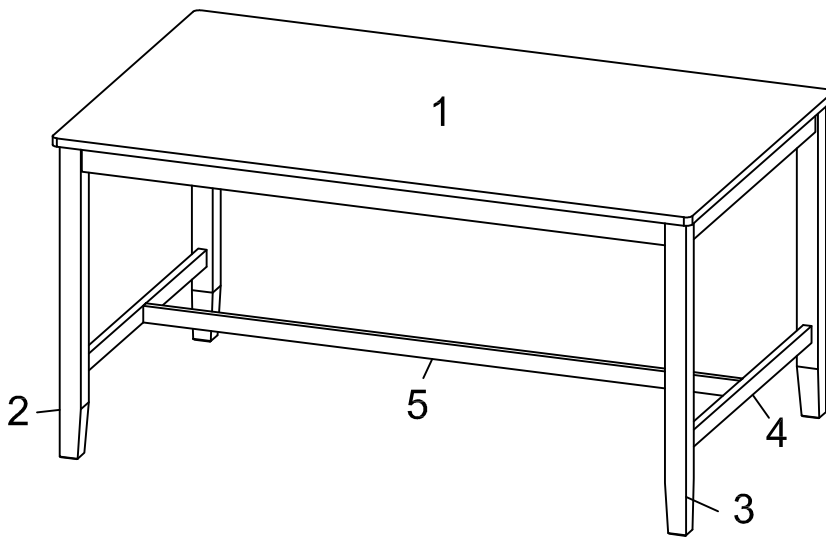

PART LISTS				HARDWARE LISTS			
NO.	DESCRIPTION	SKETCH	Q'TY	NO.	DESCRIPTION	SKETCH	Q'TY
1	TOP FRAME		1 PC	A	BOLT Ø 5/16" x 60mmL		8 PCS
2	LEGS LEFT		2 PCS	B	SPRING WASHER Ø 5/16" x 12 mm		8 PCS
3	LEGS RIGHT		2 PCS	C	FLAT WASHER Ø 5/16" x 18 mm		8 PCS
4	SIDE STRETCHERS		2 PCS	D	WOOD SCREW Ø 1/4" x 40mmL		2 PCS
5	STRETCHER		1 PC	E	SCREW Ø 4 x 40mm		4 PCS
				F	ALLEN WRENCH 4 mm		1 PC
					NOT INCLUDED		

ASSEMBLY INSTRUCTION

STEP 1 :

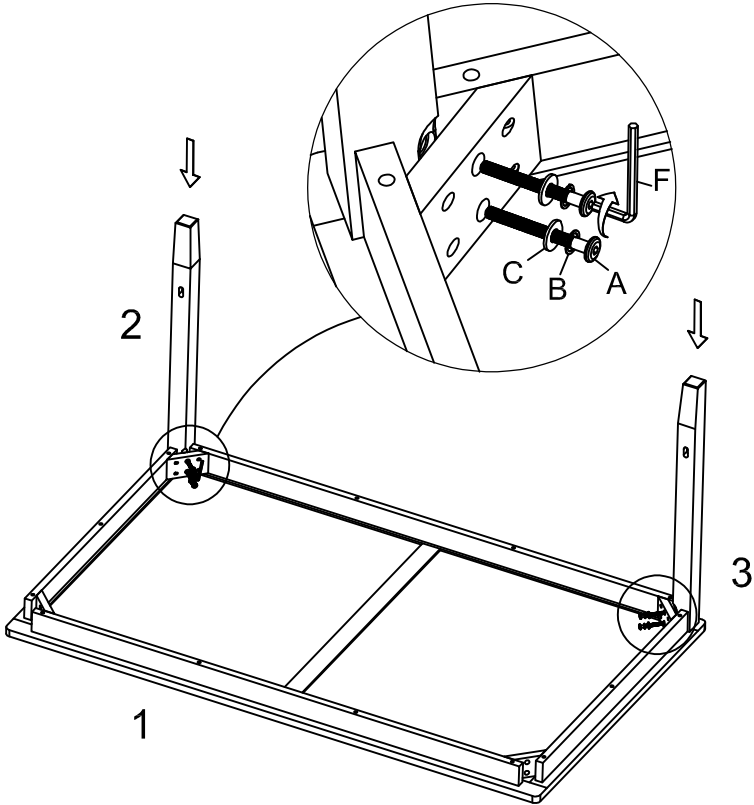

STEP 2 :

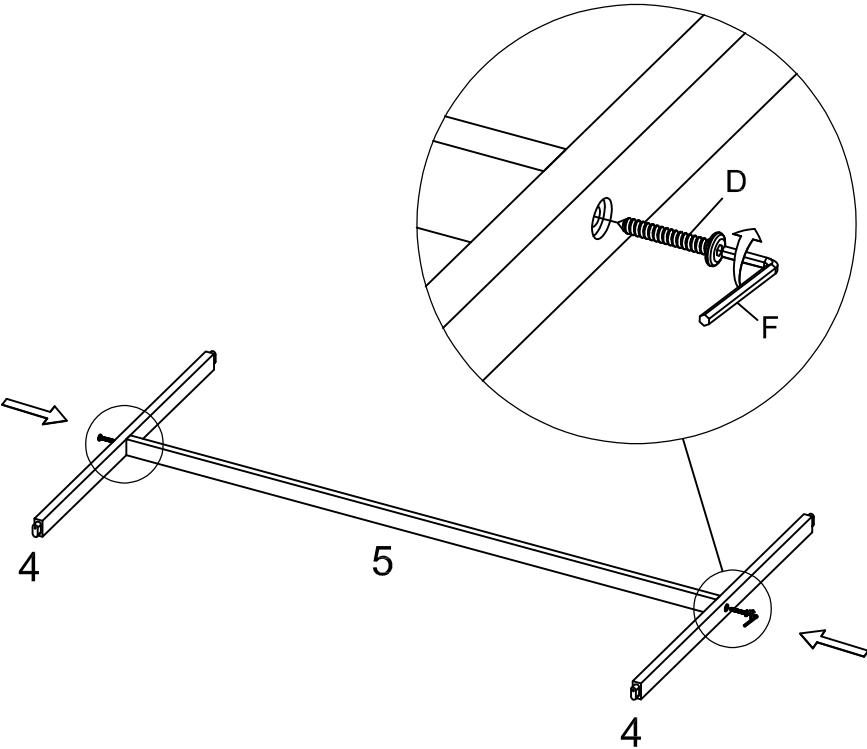

ASSEMBLY INSTRUCTIONS

STEP 3 :

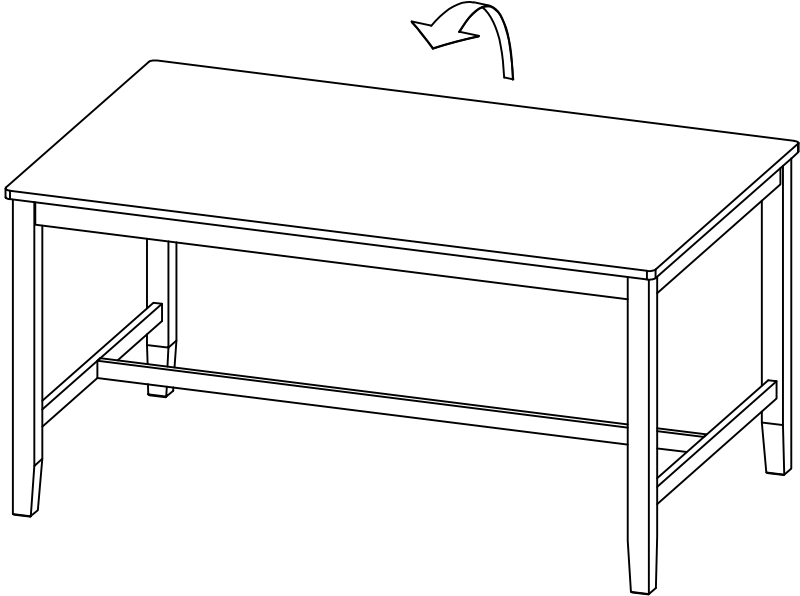
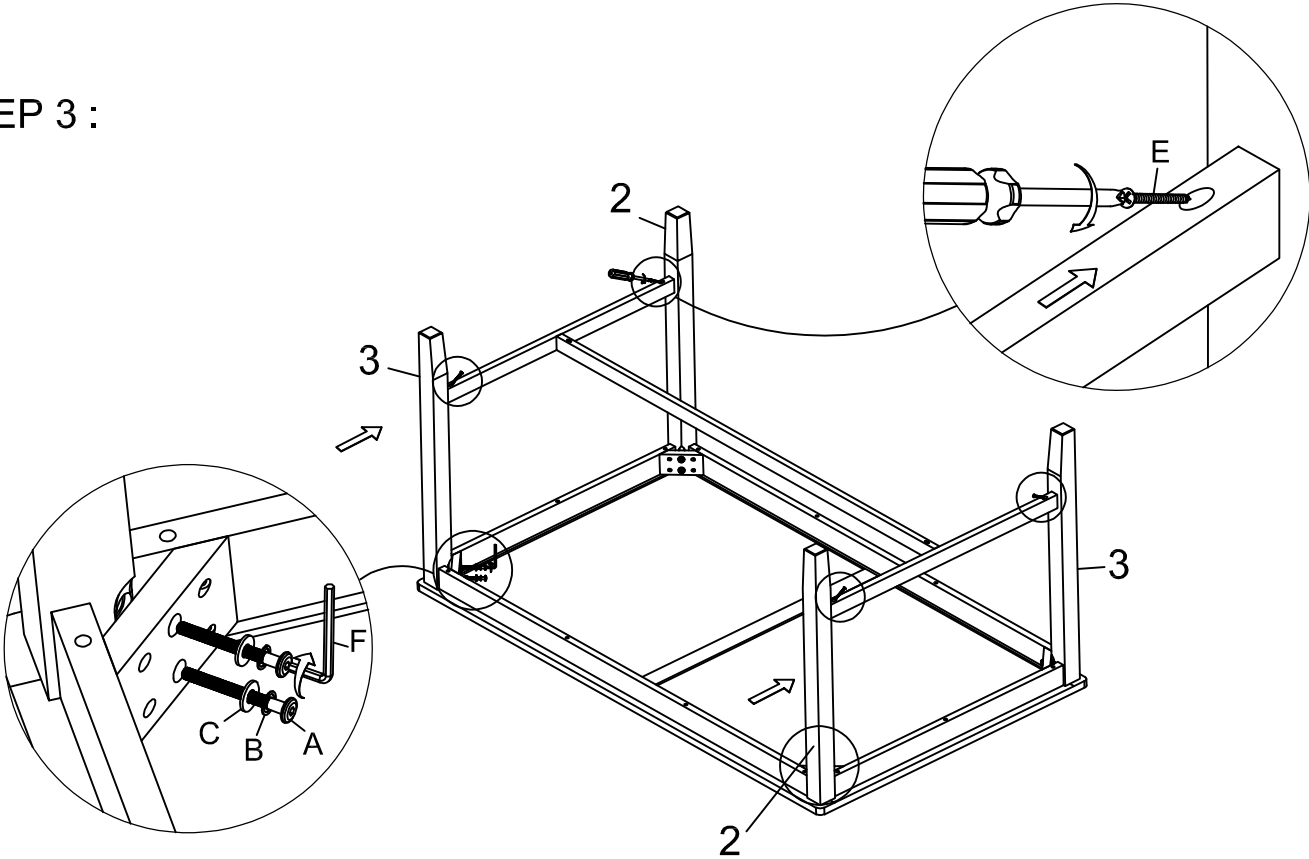

ASSEMBLY INSTRUCTION

WF322939-DINING CHAIR







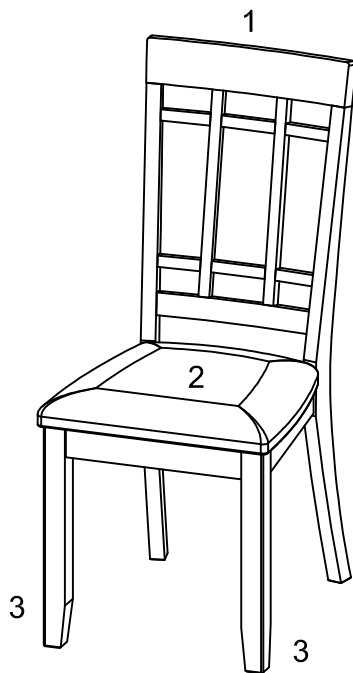

IMPORTANT NOTE :

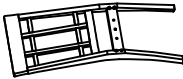
** PLACE ALL PARTS ON A CLEAN AND SMOOTH SURFACE SUCH AS A RUG OR CARPET TO AVOID THE PARTS FROM BEING SCRATCHED.

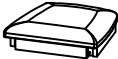
** BEFORE YOU BEGIN, KINDLY FOLLOW THE ASSEMBLY INSTRUCTIONS STEP BY STEP.

**DO NOT TIGHTEN ALL SCREWS AND BOLTS UNTIL THE CHAIR IS FULLY SET-UP.



PART LISTS FOR ONE				HARDWARE LISTS FOR ONE			
NO.	DESCRIPTION	SKETCH	Q'TY	NO.	DESCRIPTION	SKETCH	Q'TY
1	CHAIR BACK		1 PC	A	BOLT Ø1/4" x 75mmL		4 PCS
2	SEAT		1 PC	B	BOLT Ø1/4" x 60mmL		4 PCS
3	FRONT LEGS		2 PCS	C	BOLT Ø1/4" x 40mmL		2 PCS
				D	SPRING WASHER Ø1/4" x 13mmL		10 PCS
				E	FLAT WASHER Ø1/4" x 19mmL		10 PCS
				F	ALLEN KEY		1 PC

MADE IN VIET NAM

1 OF 2

ASSEMBLY INSTRUCTION

STEP1:

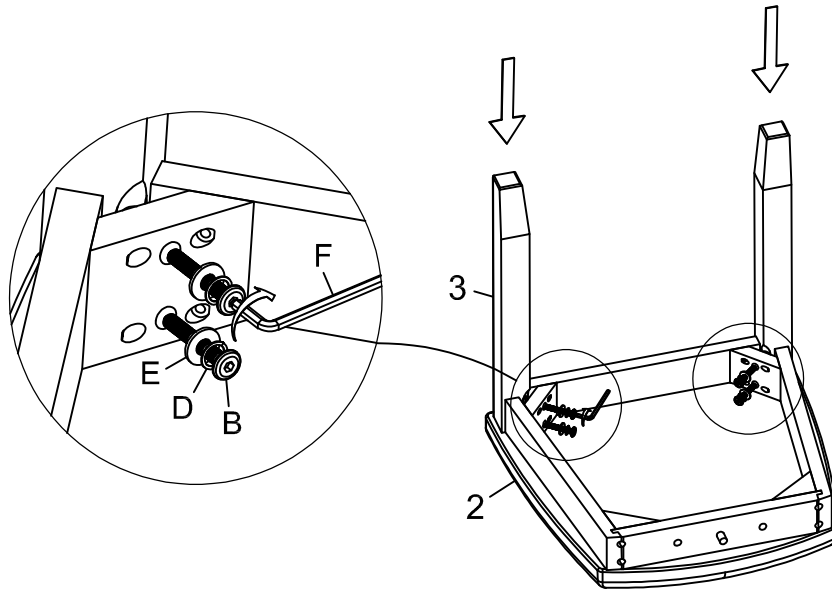

STEP2:

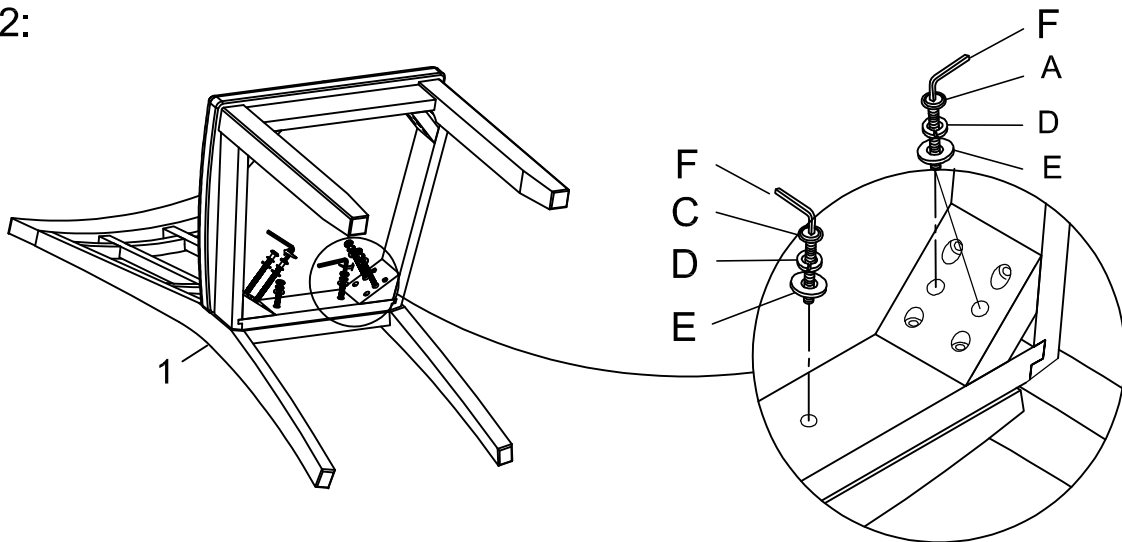

STEP3:

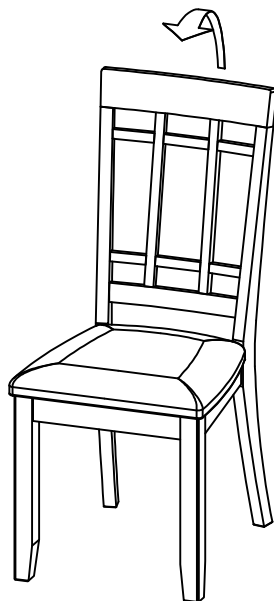

ASSEMBLY INSTRUCTION

WF322939 DINING BENCH





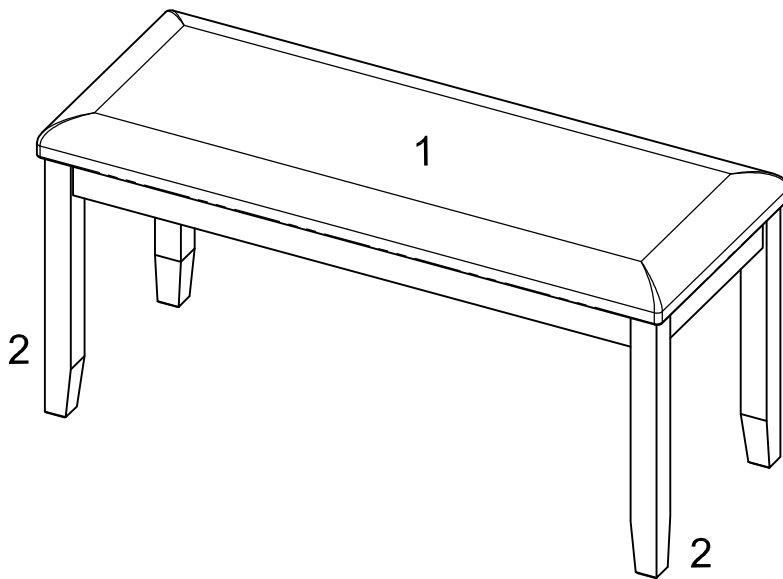

IMPORTANT NOTE :

** PLACE ALL PARTS ON A CLEAN AND SMOOTH SURFACE SUCH AS A RUG OR CARPET TO AVOID THE PARTS FROM BEING SCRATCHED.

** BEFORE YOU BEGIN, KINDLY FOLLOW THE ASSEMBLY INSTRUCTIONS STEP BY STEP.

**DO NOT TIGHTEN ALL SCREWS AND BOLTS UNTIL THE BENCH IS FULLY SET-UP.

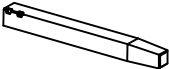

PART LISTS				HARDWARE LISTS			
NO.	DESCRIPTION	SKETCH	Q'TY	NO.	DESCRIPTION	SKETCH	Q'TY
1	TOP FRAME		1 PC	A	BOLT Ø 1/4" x 60mmL		8 PCS
				B	SPRING WASHER Ø 1/4" x 12 mm		8 PCS
				C	FLAT WASHER Ø 1/4" x 18 mm		8 PCS
2	LEGS		4 PCS	D	ALLEN WRENCH 4 mm		1 PC

ASSEMBLY INSTRUCTION

STEP 1 :

