

# ASSEMBLY INSTRUCTIONS

## DINING TABLE

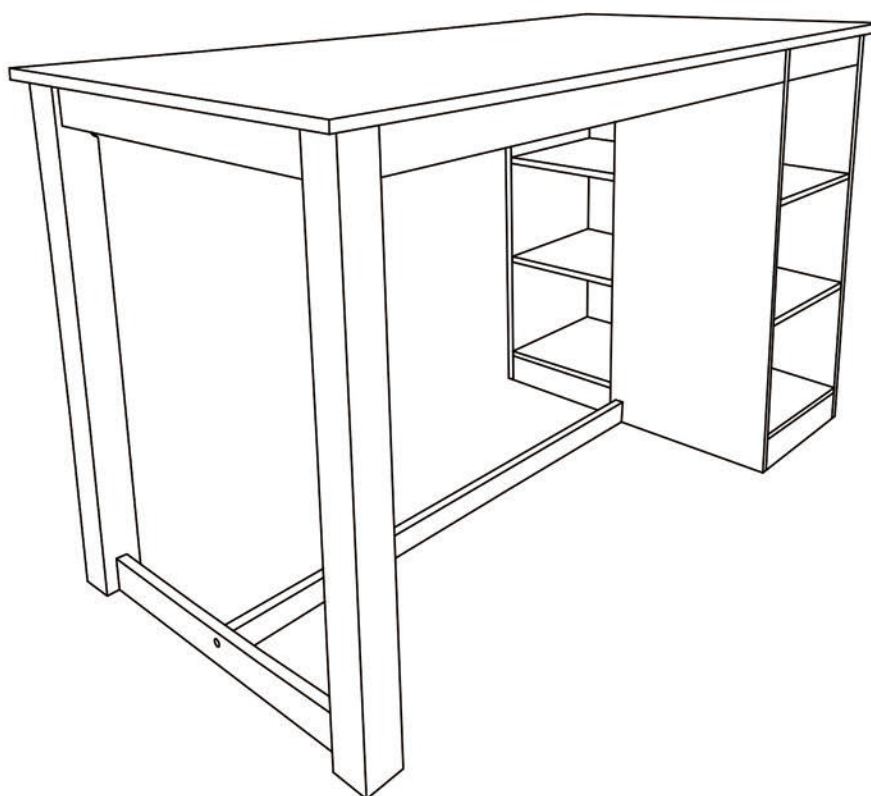

WF318530

### IMPORTANT NOTE:

- PLACE ALL PARTS ON A CLEAN AND SMOOTH SURFACE SUCH AS A RUG OR CARPET TO AVOID THE PARTS FROM BEING SCRATCHED.
- BEFORE YOU BEGIN, KINDLY FOLLOW THE ASSEMBLY INSTRUCTIONS STEP BY STEP.
- DON NOT TIGHTEN ALL SCREWS AND BOLTS UNTIL THE TABLE SET IS FULLY SET-UP.

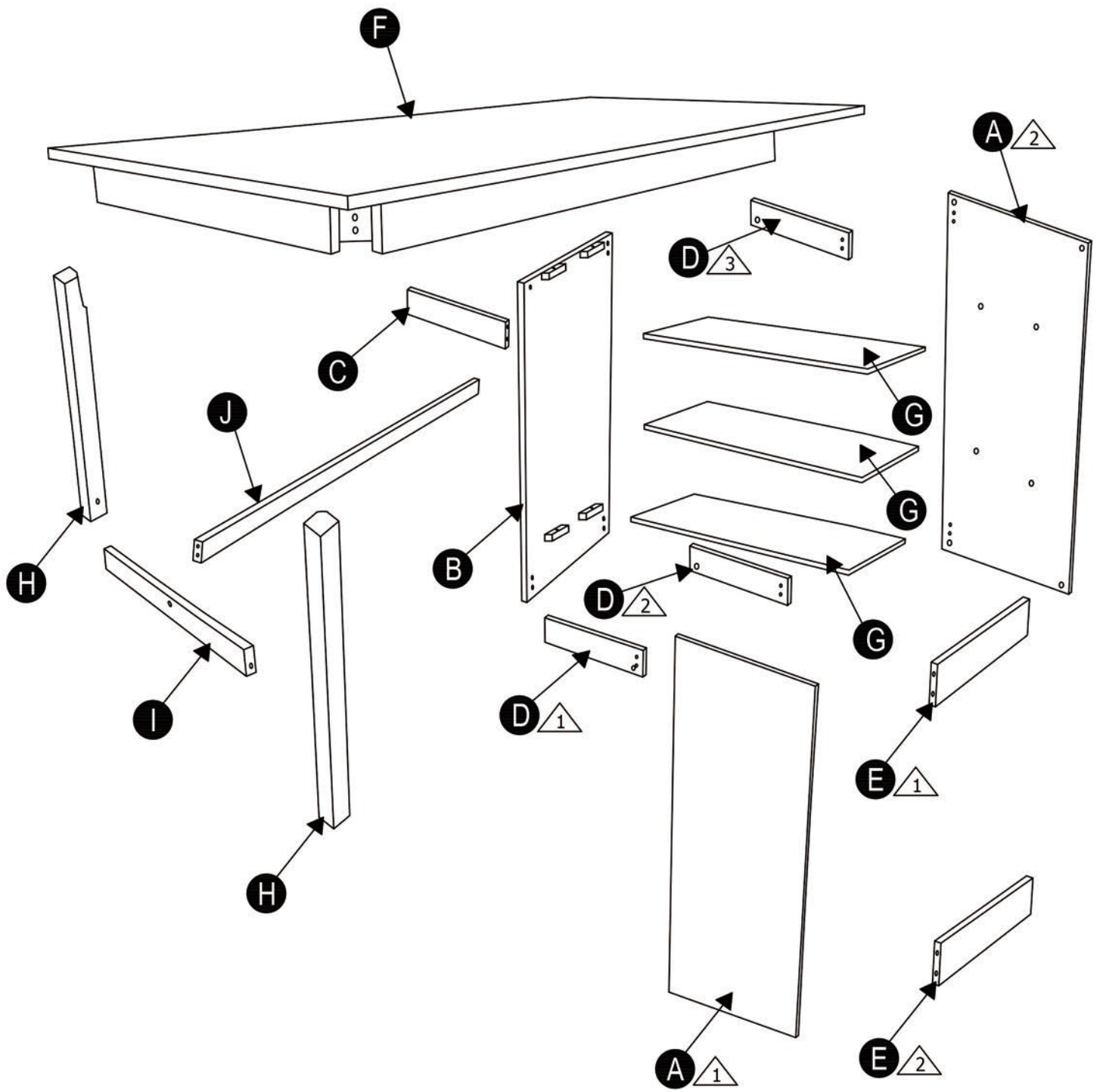

# CARTON CONTENT



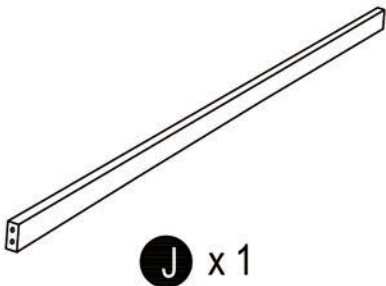
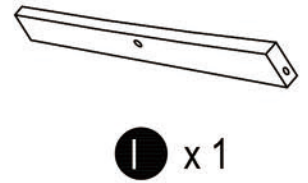
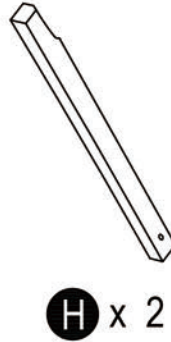
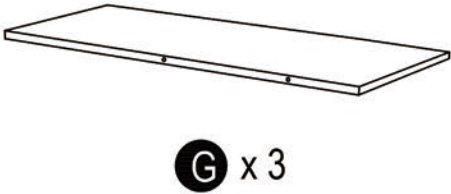
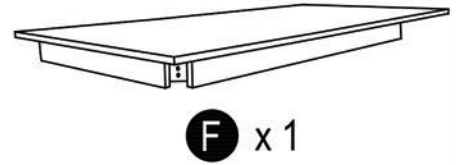
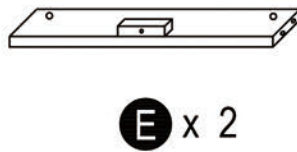
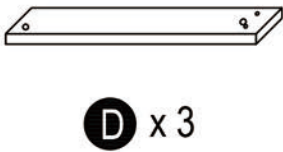
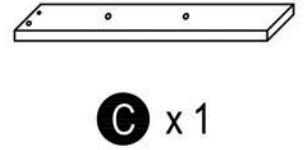
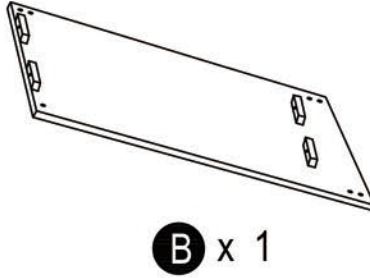
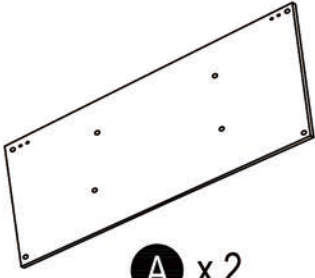







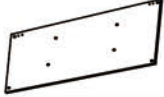





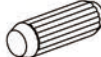

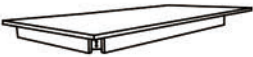



WF318530:

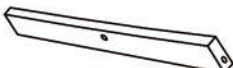

# CARTON CONTENT

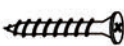
## TABLE PART LIST FOR ONE

## TABLE HARDWARE LIST FOR ONE

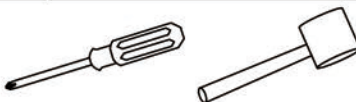
TABLE PART LIST FOR ONE				TABLE HARDWARE LIST FOR ONE			
NO	DESCRIPTION	SKETCH	QTY	NO	DESCRIPTION	SKETCH	QTY
A	SIDE BOARD (1 & 2)		2 PCS	1	S4 SHELF SUPPORT		12 PCS
B	BACK BOARD		1 PC	2	SIM FITTING		8 PCS
C	SIDE RAIL 1		1 PC	3	HF FITTING		8 PCS
D	SIDE RAIL 2 (1, 2 & 3)		3 PCS	4	WOOD DOWEL M8 x 30MM		10 PCS
E	FRONT RAIL (1 & 2)		2 PCS	5	JCBC SCREW M6 x 25MM		4 PCS
F	TABLE TOP		1 PC	6	JCBC SCREW M8 x 60MM		4 PCS
G	SHELF BOARD		3 PCS	7	JCBC SCREW M6 x 40MM		2 PCS
H	TABLE LEG		2 PCS	8	SPRING WASHER M6		6 PCS
I	STRETCHER SHORT		1 PC	9	SPRING WASHER M8		4 PCS
J	STRECTHER LONG		1 PC	10	FLAT WASHER M6 x 13MM		6 PCS
				11	FLAT WASHER M8 x 22MM		4 PCS
				12	CSK SCREW M4 x 25MM		12 PCS
				13	CSK SCREW M4 x 32MM		2 PCS
				14	WOOD BUTTON 14.5mm		1 PC
				15	ALLEN KEY M4		1 PC
				16	ALLEN KEY M5		1 PC
				NOT INCLUDED			
							

STEP 1

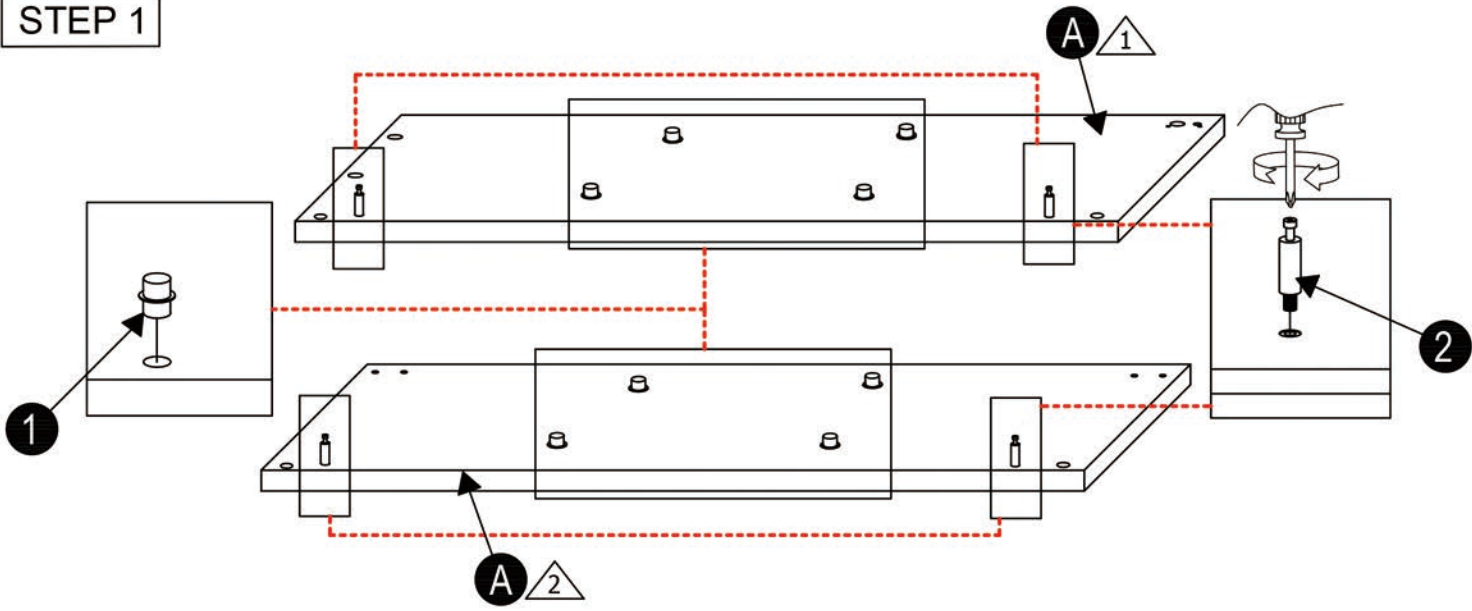

STEP 2

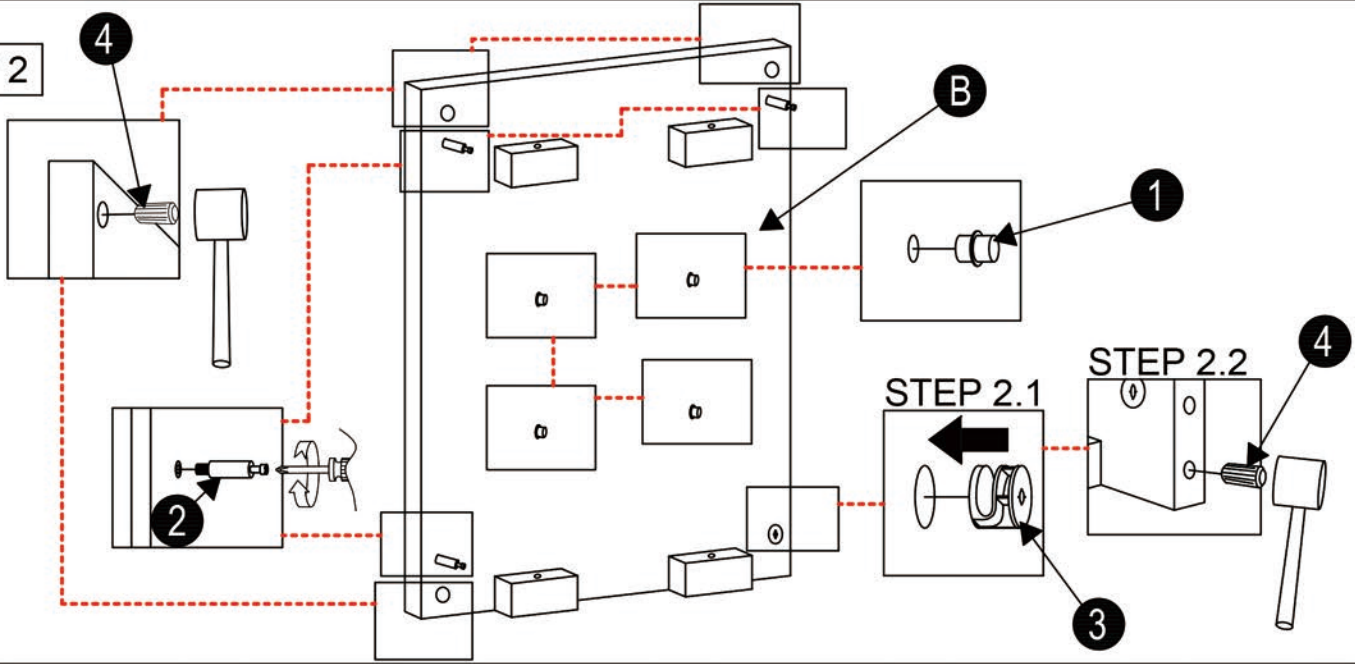

STEP 3

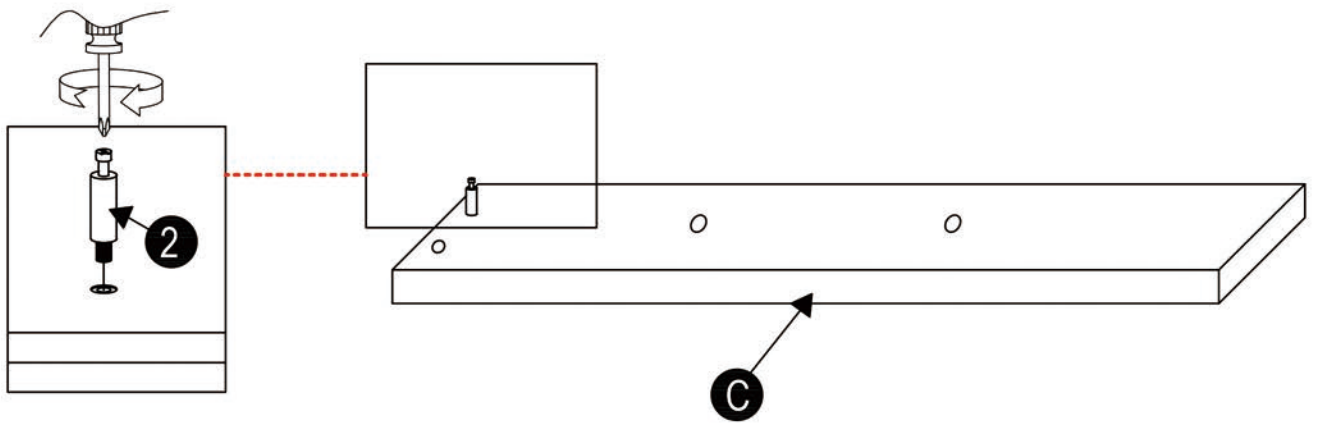

STEP 4

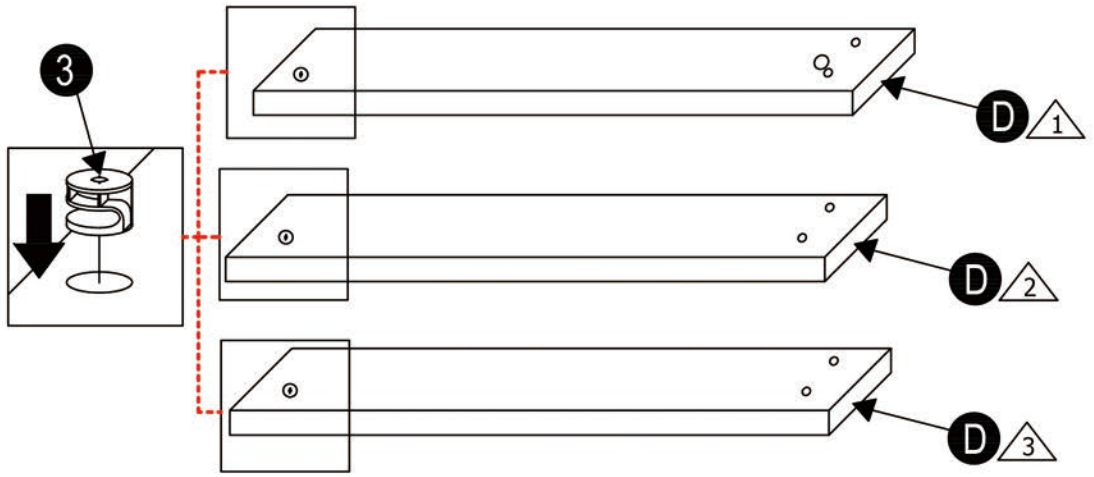

STEP 5

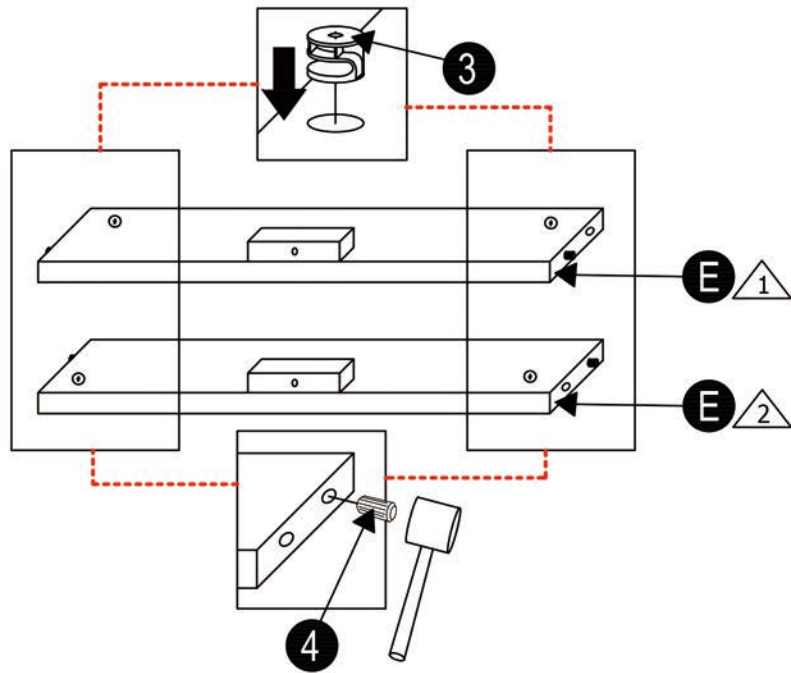

STEP 6

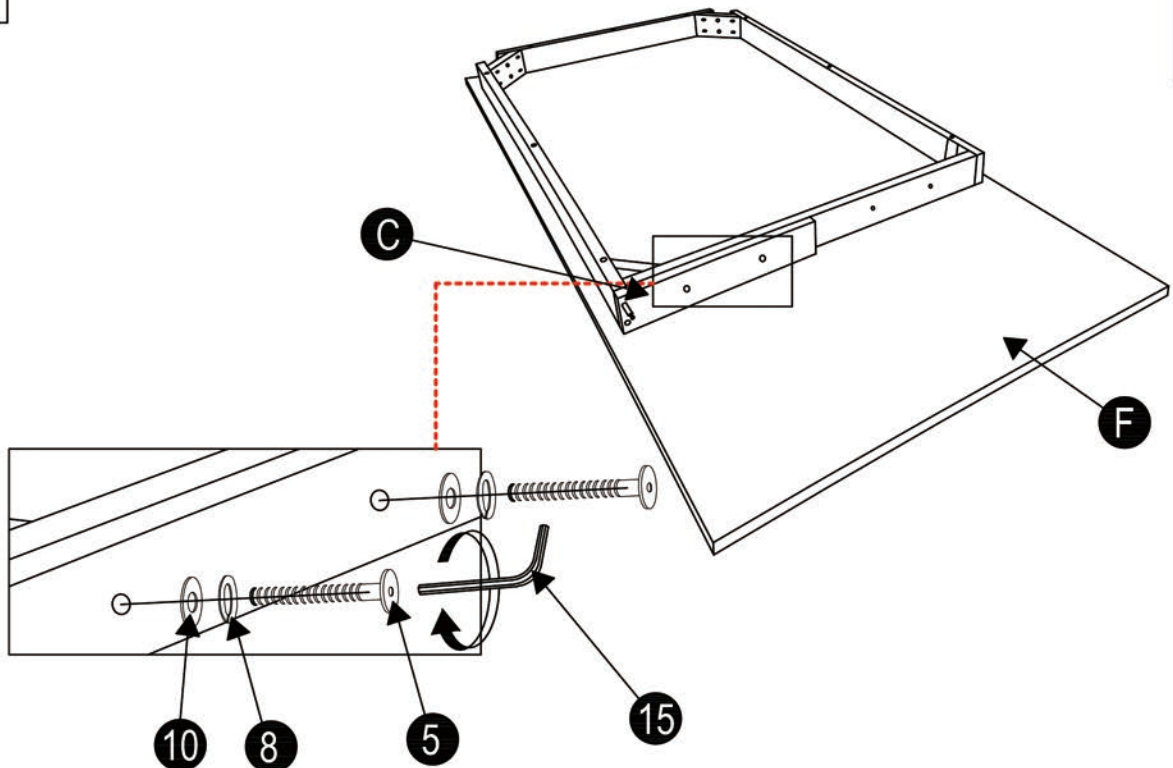

STEP 7

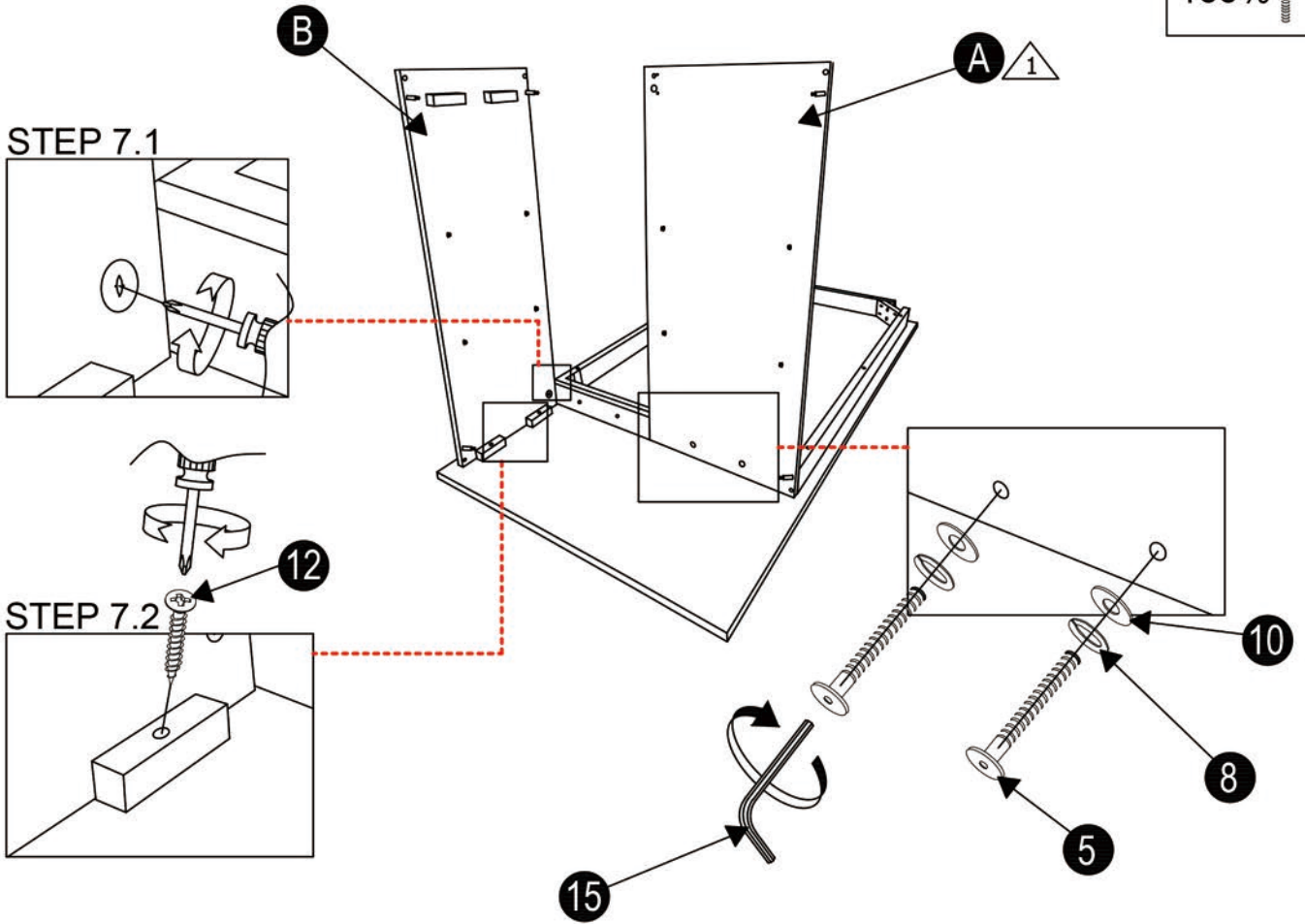

STEP 7.1

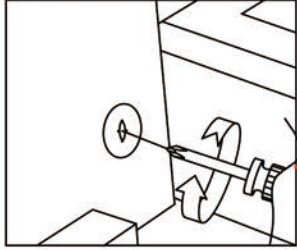

STEP 7.2

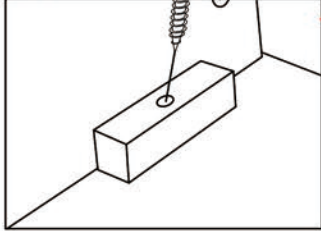

STEP 8

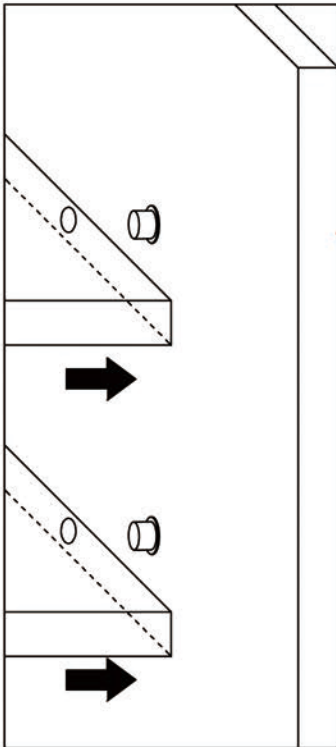
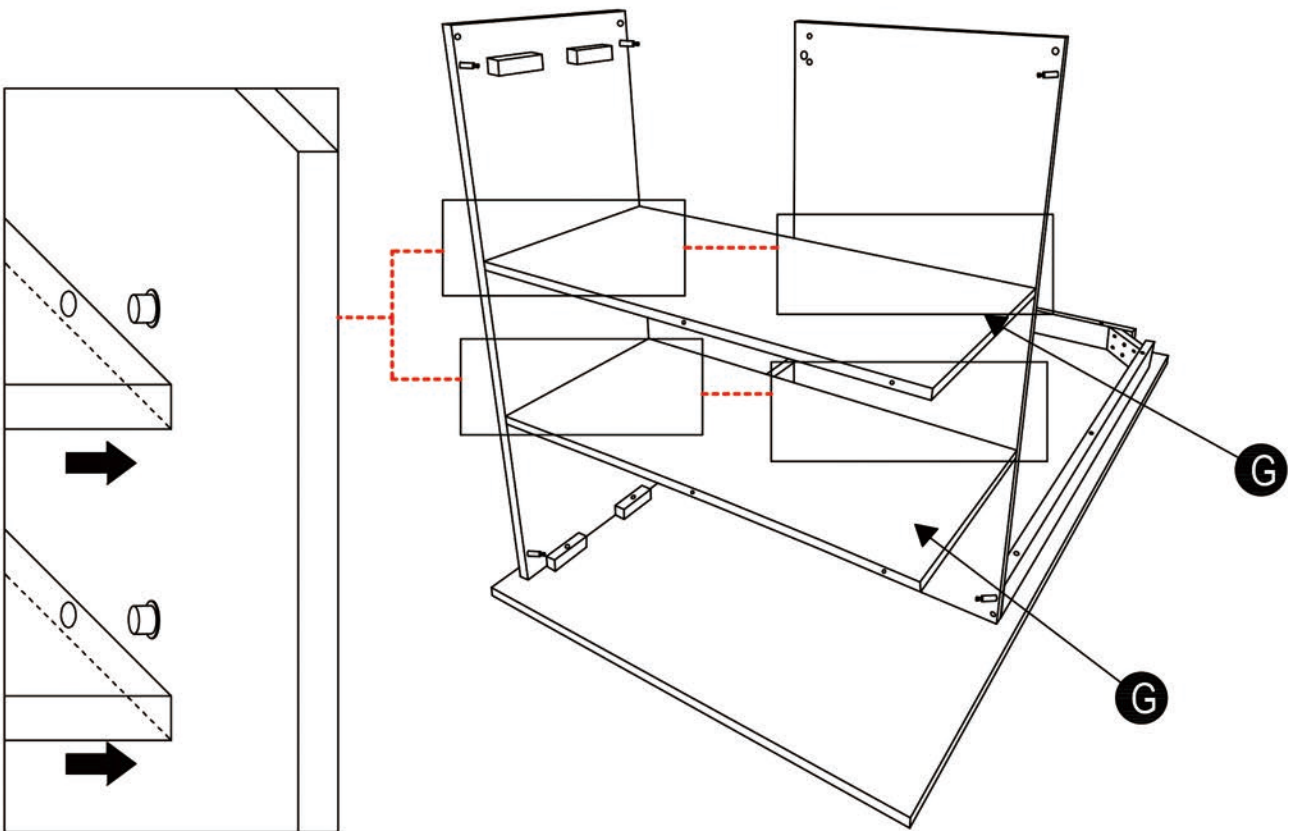

STEP 9

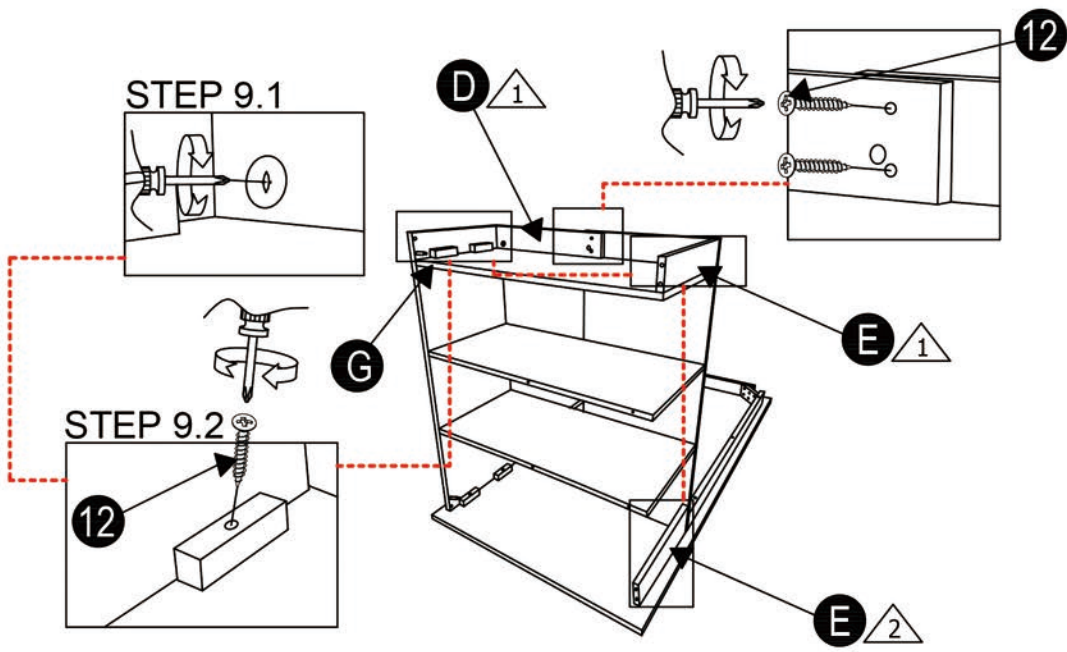

STEP 10

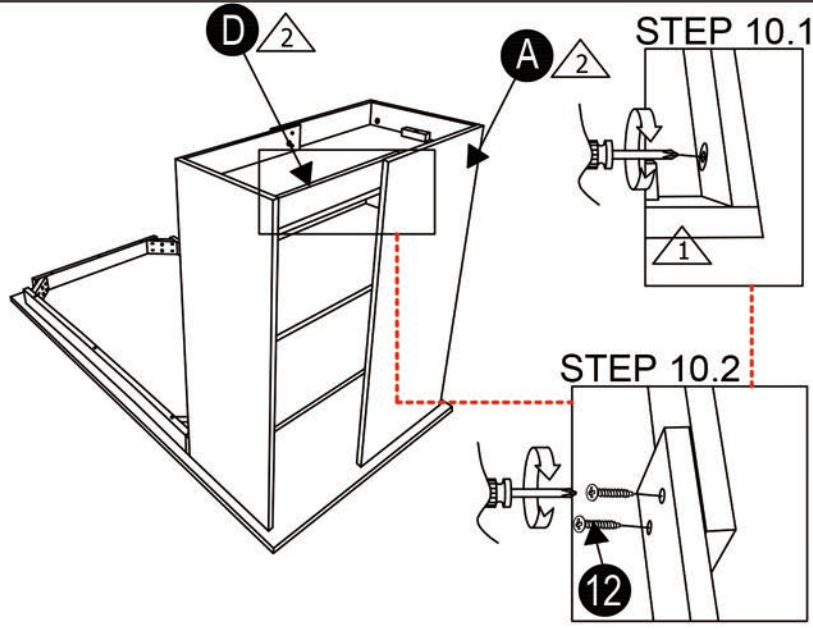
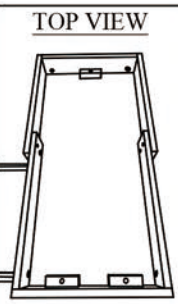

STEP 11

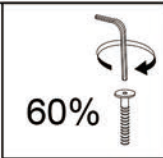
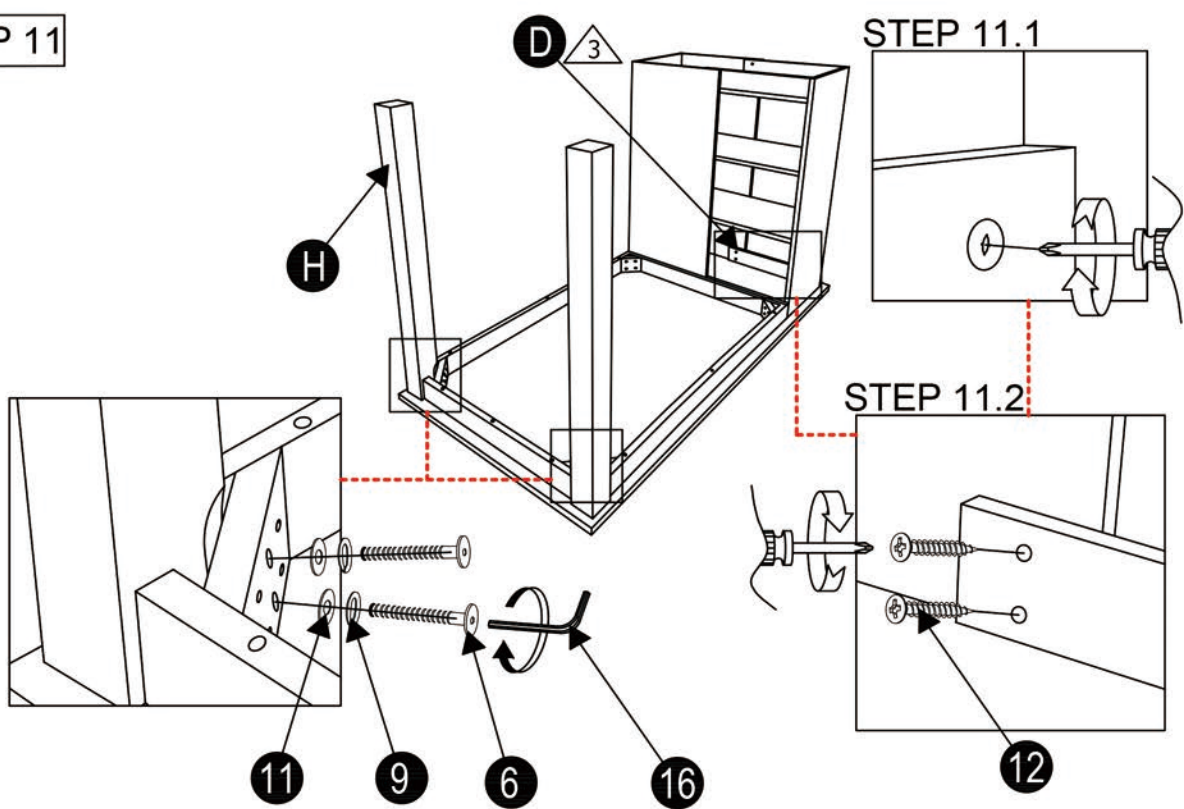



STEP 12

100% 

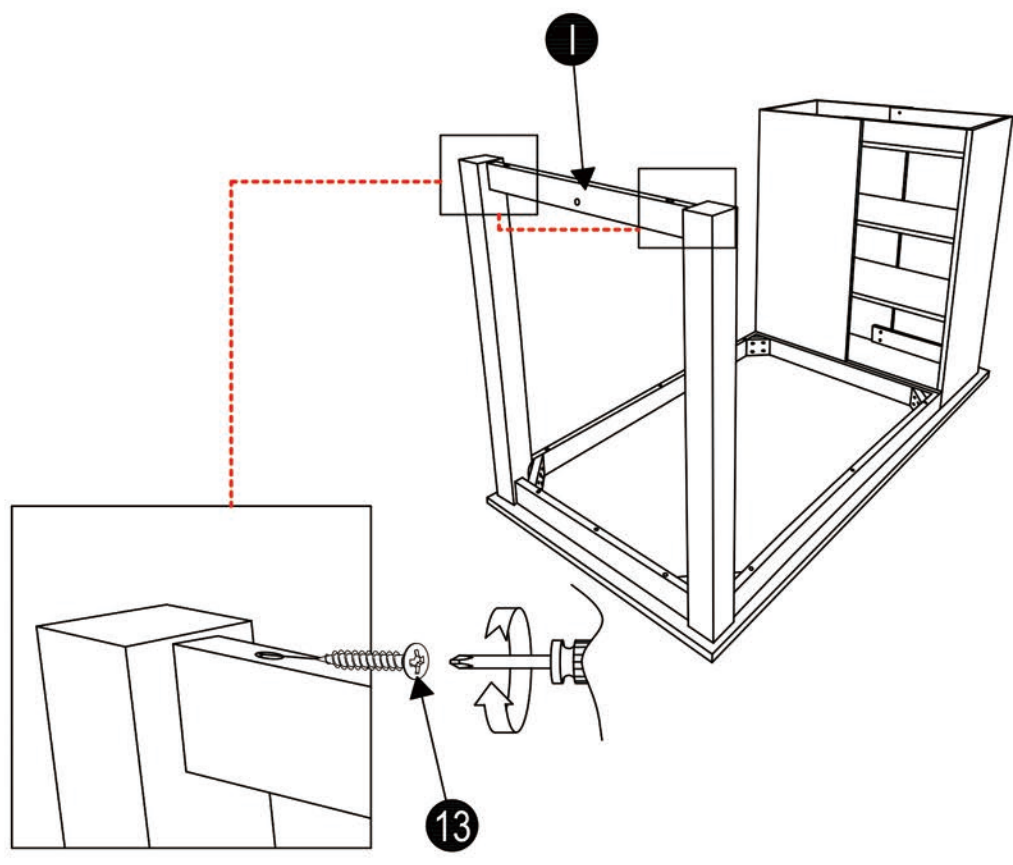

STEP 13

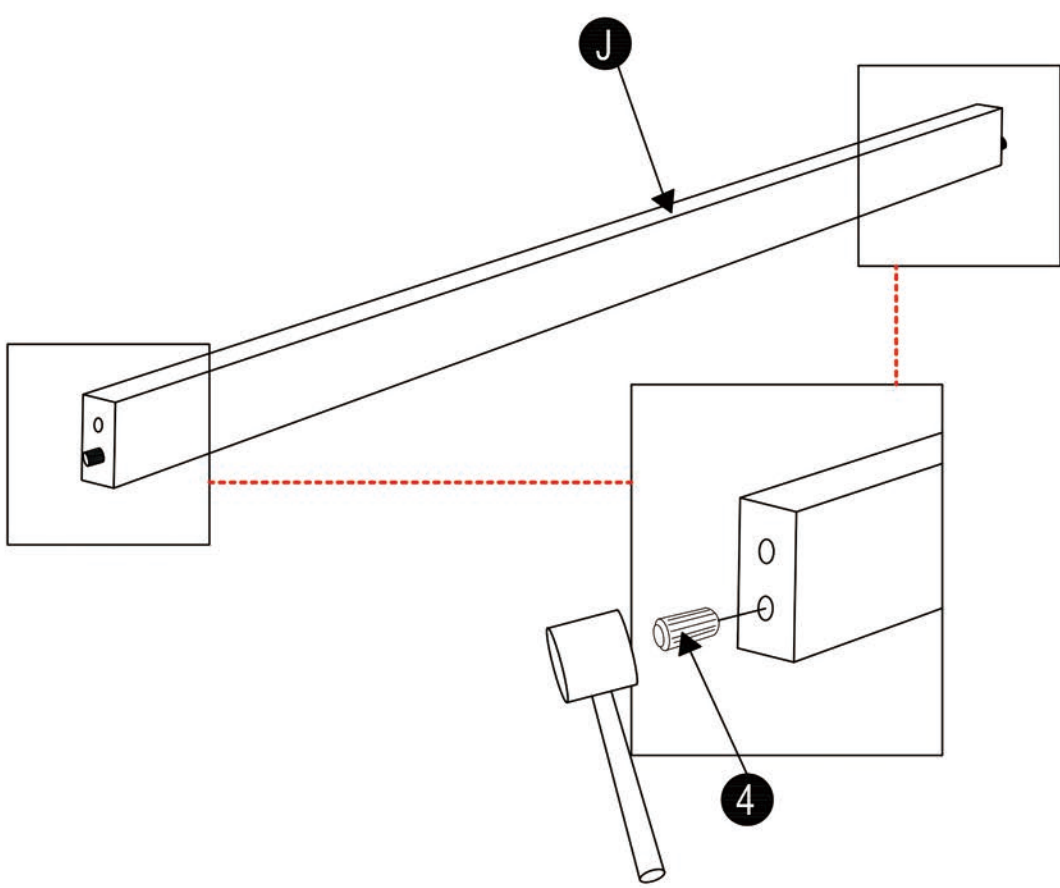

STEP 14

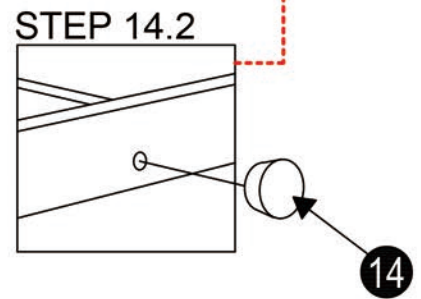
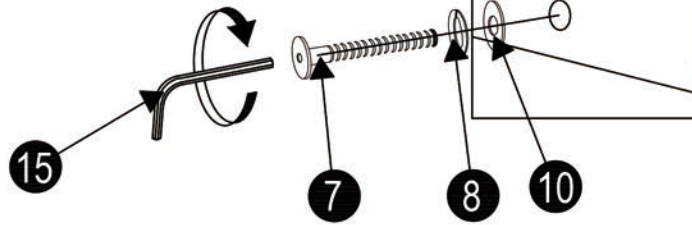
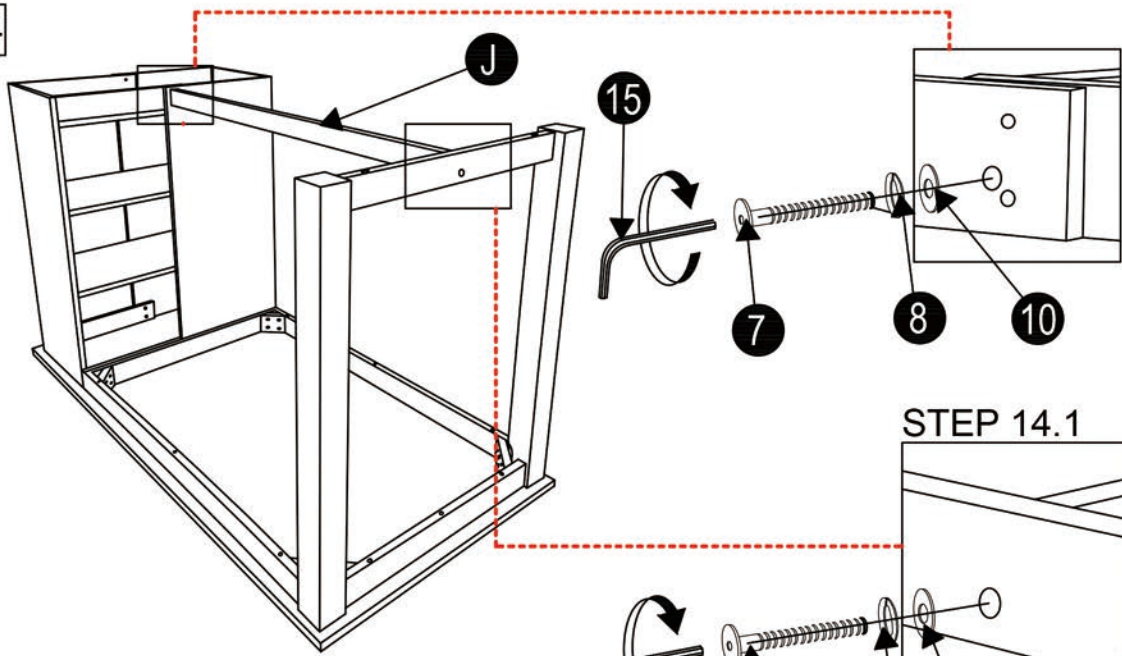

ASSEMBLY COMPLETE !

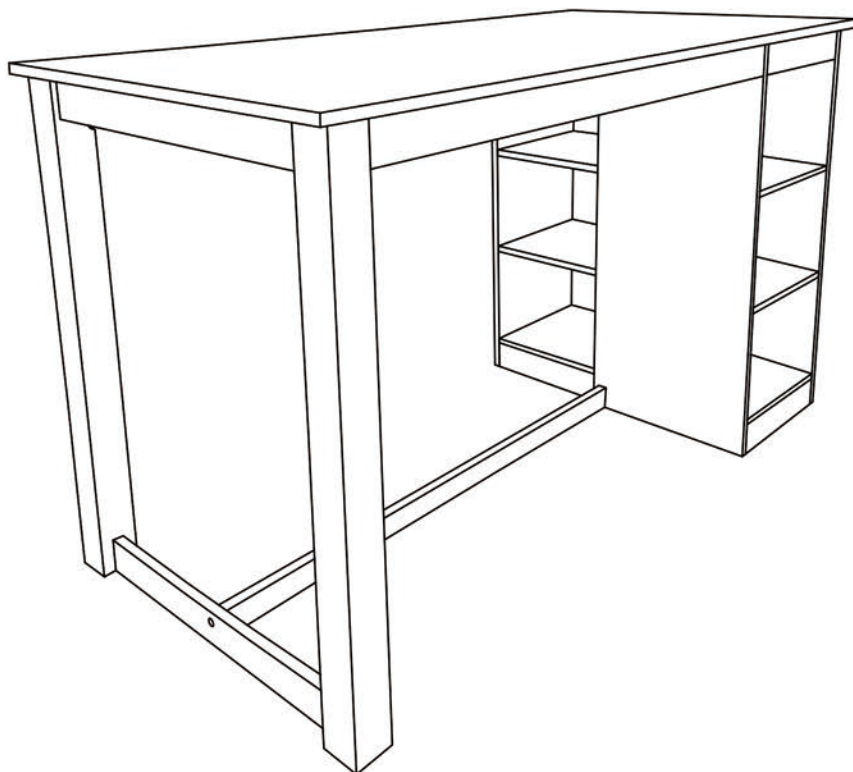

# ASSEMBLY INSTRUCTIONS

## DINING CHAIR

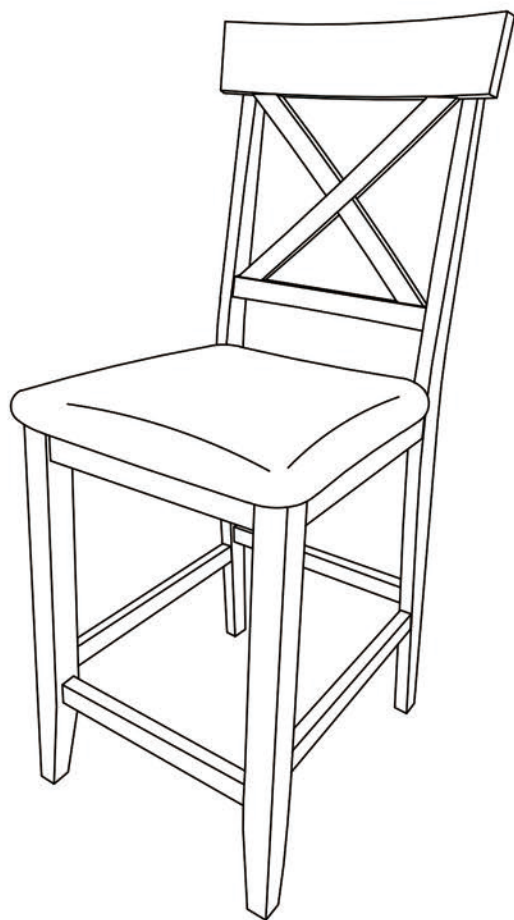

WF318531

### IMPORTANT NOTE:

- PLACE ALL PARTS ON A CLEAN AND SMOOTH SURFACE SUCH AS A RUG OR CARPET TO AVOID THE PARTS FROM BEING SCRATCHED.
- BEFORE YOU BEGIN, KINDLY FOLLOW THE ASSEMBLY INSTRUCTIONS STEP BY STEP.
- DON NOT TIGHTEN ALL SCREWS AND BOLTS UNTIL THE CHAIR SET IS FULLY SET-UP.

# CARTON CONTENT

WF318531:

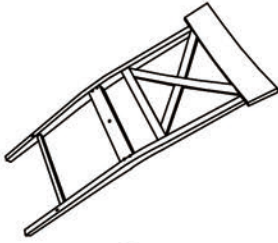

**A** x 4

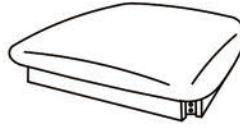

**B** x 4



**C** x 8













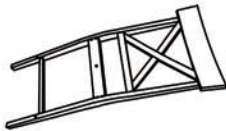

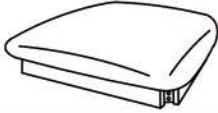
**D** x 8



**E** x 4

## CHAIR PART LIST FOR ONE

## CHAIR HARDWARE LIST FOR ONE

NO	DESCRIPTION	SKETCH	QTY	NO	DESCRIPTION	SKETCH	QTY
A	CHAIR BACK		1 PC	1	JCBC SCREW M6 x 35 MM		1 PCS
B	CUSHION SEAT WITH APRON		1 PC	2	JCBC SCREW M6 x 60 MM		4 PCS
C	FRONT LEG		2 PCS	3	JCBC SCREW M6 x 70 MM		4 PCS
D	SIDE STRETCHER		2 PCS	4	SPRING WASHER M6		9 PCS
E	FRONT STRETCHER		1 PC	5	FLAT WASHER M6 x 19 MM		9 PCS
				6	CSK SCREW M4 x 32 MM		6 PCS
				7	ALLEN KEY M4		1 PC
				NOT INCLUDED			

STEP 1

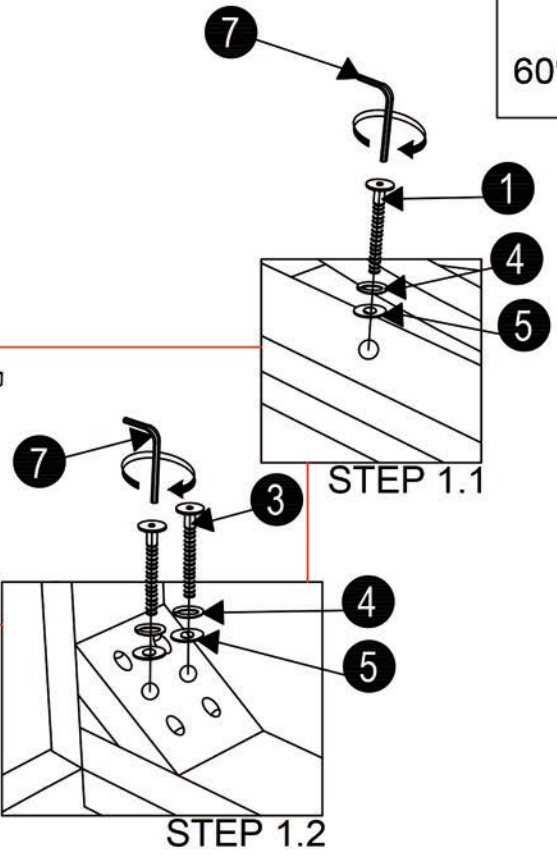
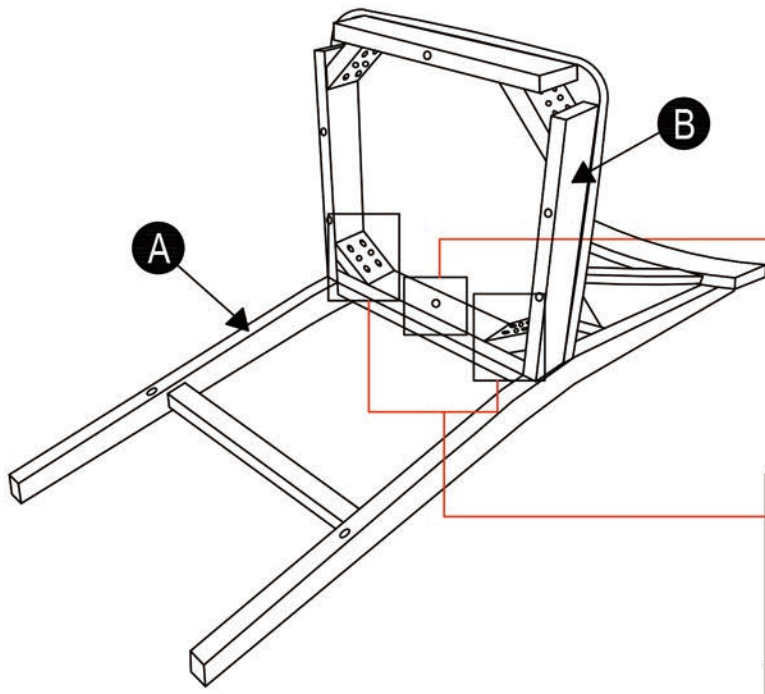

STEP 2

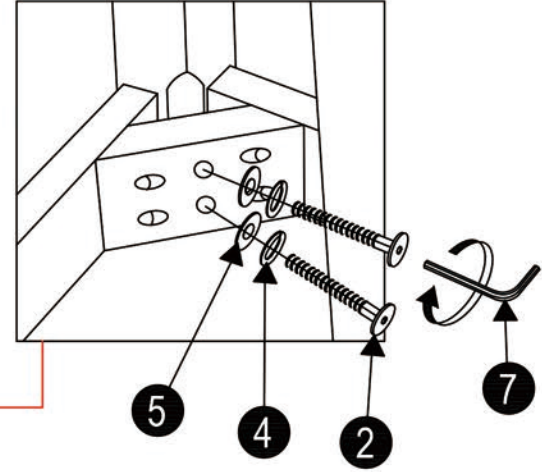
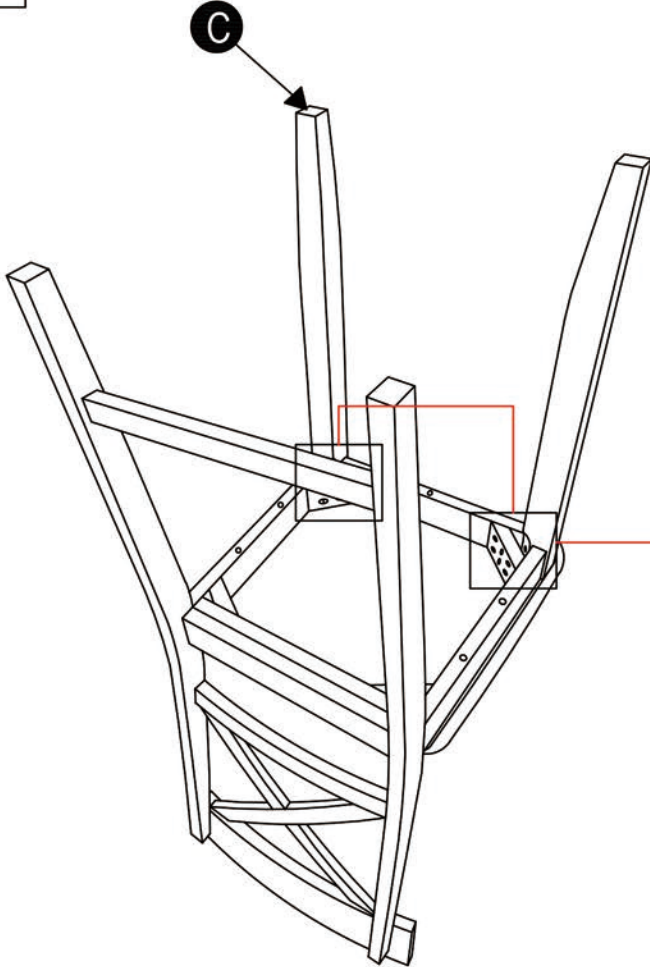

STEP 3

100% 

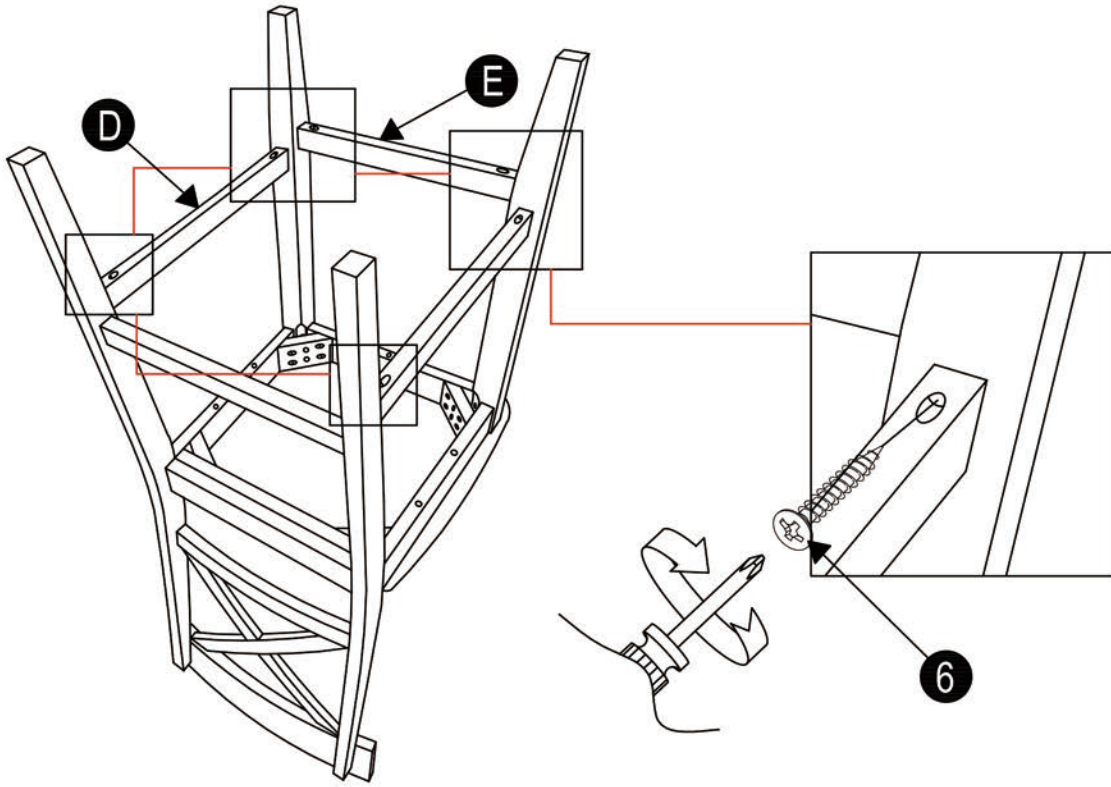

STEP 4

ASSEMBLY COMPLETE !

