

ASSEMBLY INSTRUCTIONS

WF3177800 - DINING TABLE

IMPORTANT NOTE :







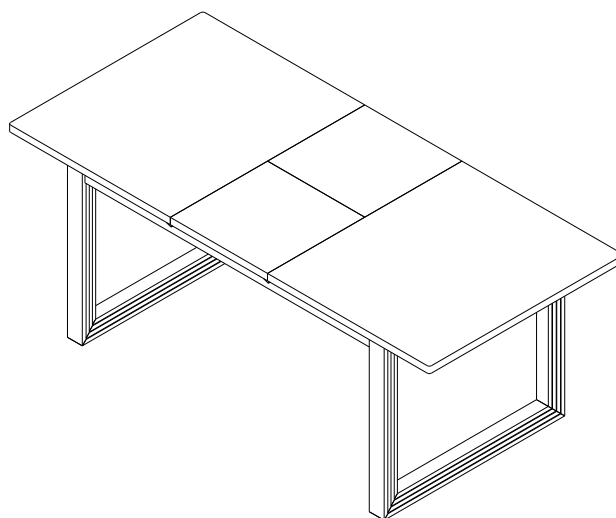

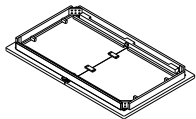

** PLACE ALL PARTS ON A CLEAN AND SMOOTH SURFACE SUCH AS A RUG OR CARPET TO AVOID THE PARTS FROM BEING SCRATCHED.

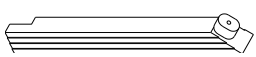
** BEFORE YOU BEGIN, KINDLY FOLLOW THE ASSEMBLY INSTRUCTIONS STEP BY STEP.

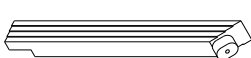
**DO NOT TIGHTEN ALL SCREWS AND BOLTS UNTIL THE DINING TABLE IS FULLY SET-UP.

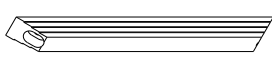

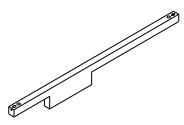
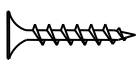
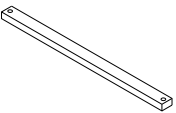
CARTONS ONLY ONE/ CARTONS SEULEMENT UN

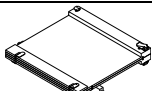
PART LISTS				HARDWARE LISTS			
NO.	DESCRIPTION	SKETCH	Q'TY	NO.	DESCRIPTION	SKETCH	Q'TY
A	TABLE TOP		1PC	1	BOLT(M8X60mm)		12PCS
B1	LEFT LEGS		2PCS	2	BOLT(M6X40mm)		6PCS
B2	RIGHT LEGS		2PCS	3	Spring washer (8.5/11mm)		12PCS
C	LEG CENTER		2PCS	4	Flat washer (8.5/19mm)		12PCS
D	TABLE TOP CONNECTION BAR CENTER		2PCS	5	Screw (M4 x 35mm)		4PCS
E	VERTICAL BRACE		1PC	6	ALLEN KEY		1PC
F	TABLE LEAF		1PC				

ASSEMBLY INSTRUCTIONS

STEP 1:

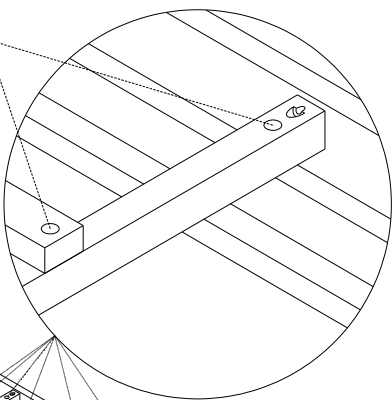
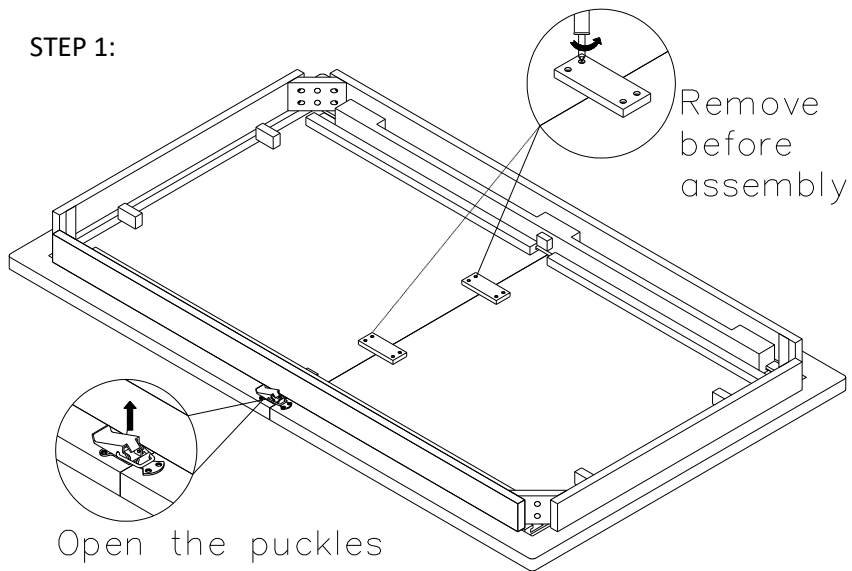

STEP 2:

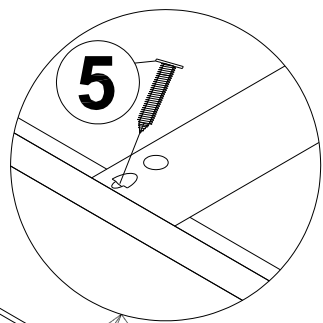
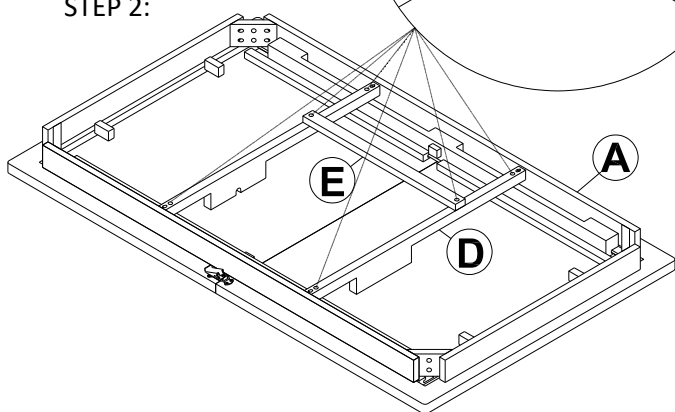

STEP 3:

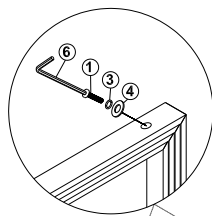
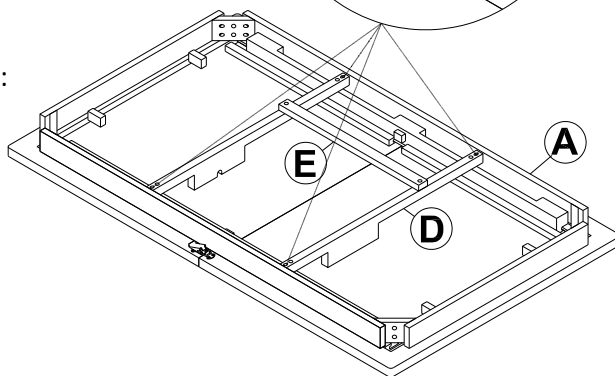

STEP 4:

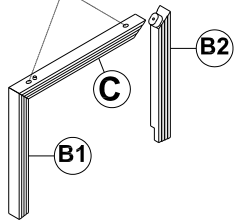

ASSEMBLY INSTRUCTIONS

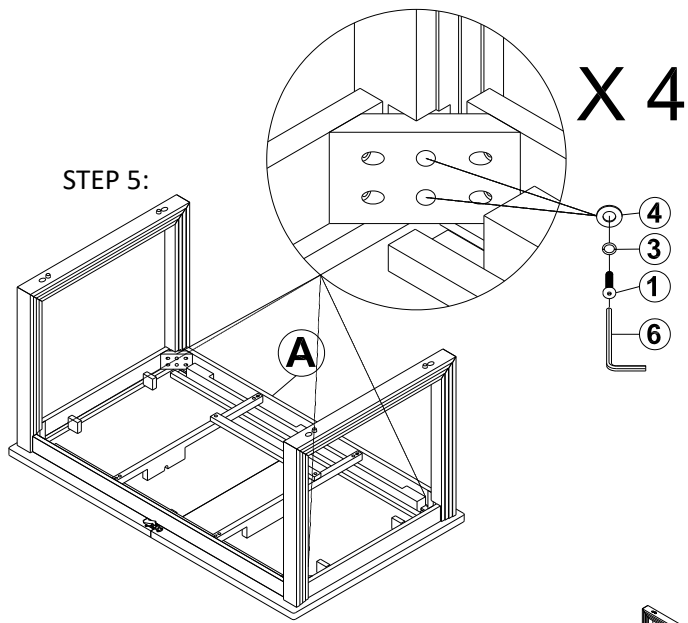

STEP 6:

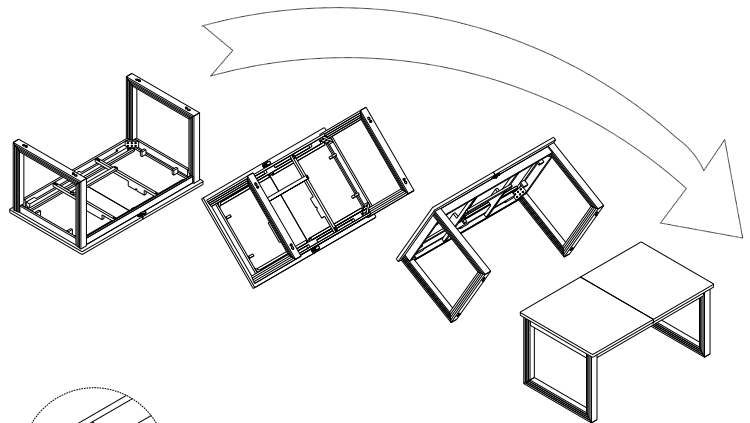

STEP 7:

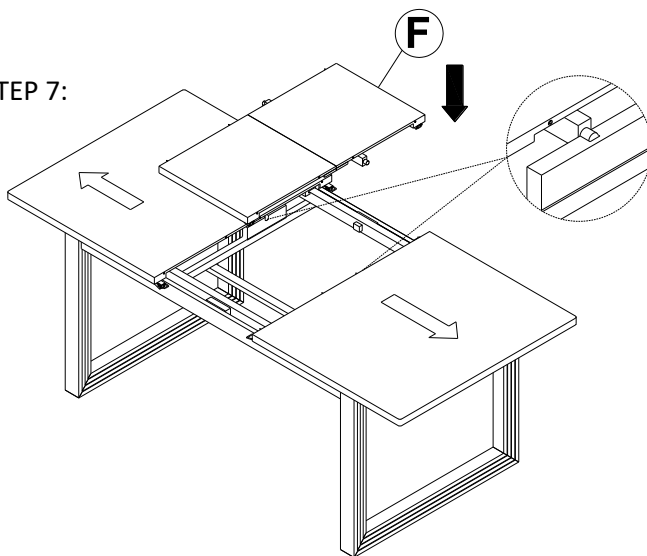

STEP 8:

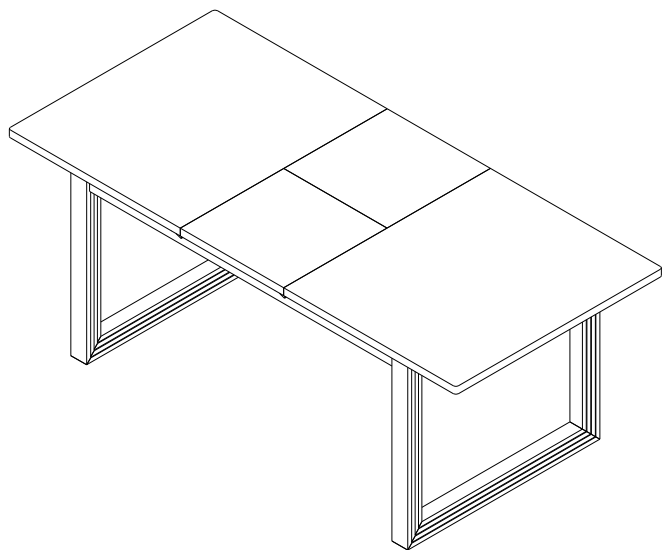

ASSEMBLY INSTRUCTIONS

STEP 9:

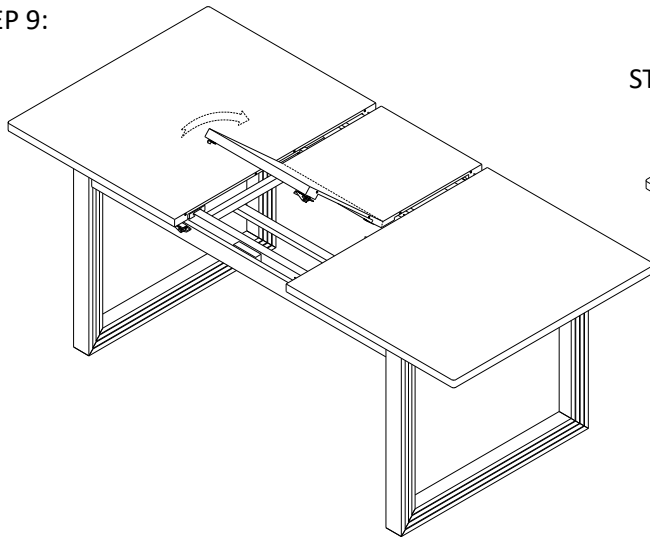

STEP 10:

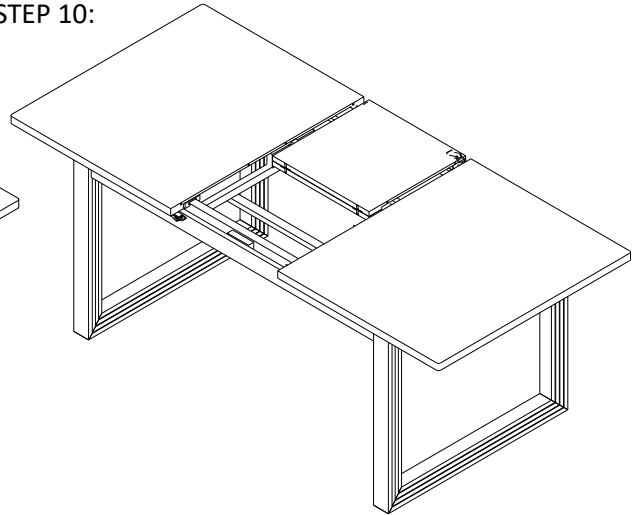

STEP 11:

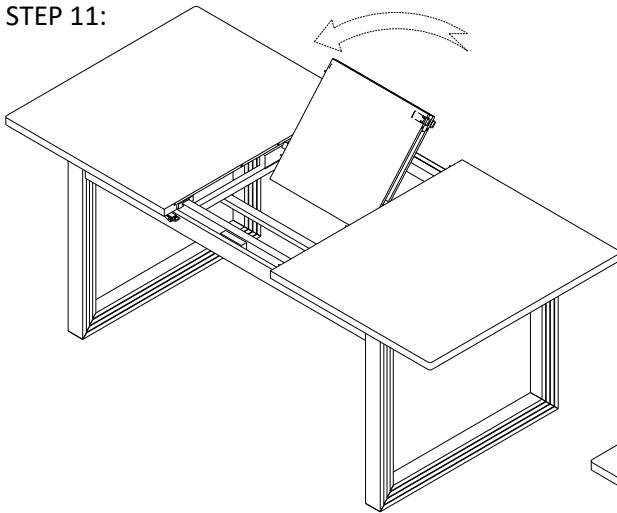

STEP 12:

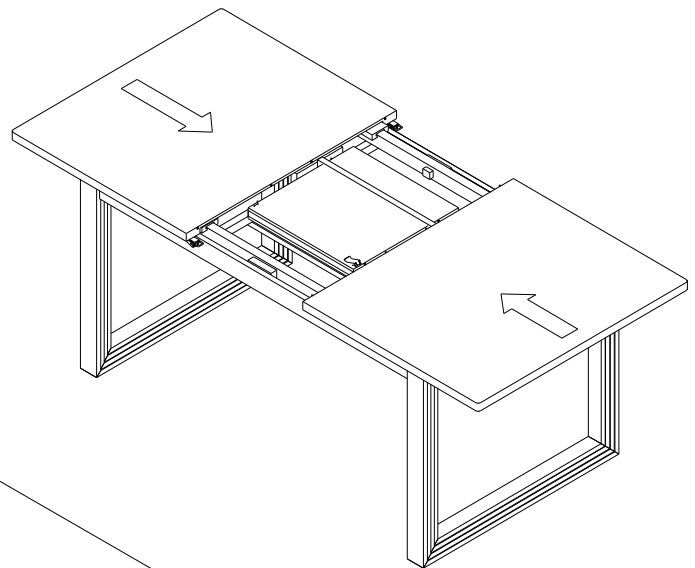

STEP 13:

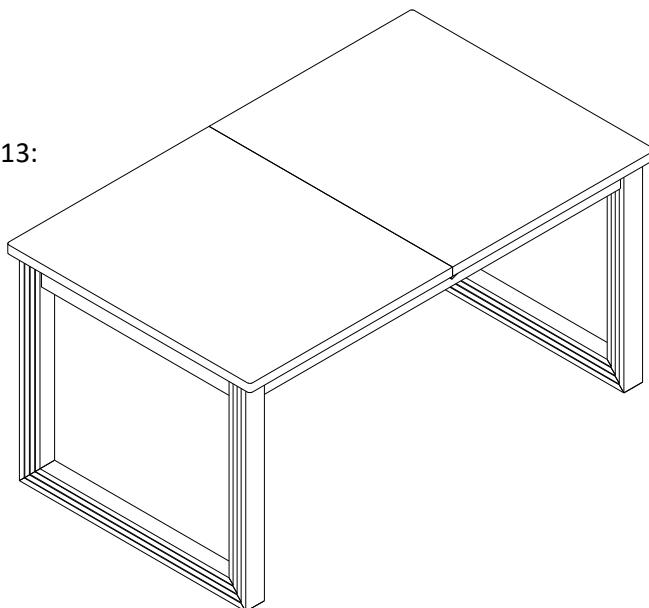

ASSEMBLY INSTRUCTIONS

WF317801 - DINING CHAIRS





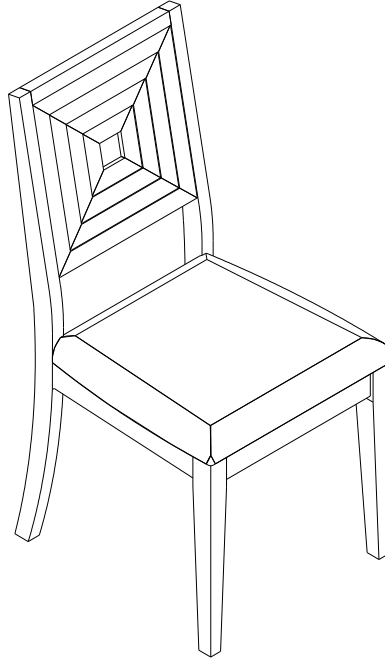

IMPORTANT NOTE :

** PLACE ALL PARTS ON A CLEAN AND SMOOTH SURFACE SUCH AS A RUG OR CARPET TO AVOID THE PARTS FROM BEING SCRATCHED.

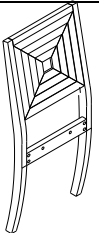
** BEFORE YOU BEGIN, KINDLY FOLLOW THE ASSEMBLY INSTRUCTIONS STEP BY STEP.

**DO NOT TIGHTEN ALL SCREWS AND BOLTS UNTIL THE DINING CHAIRS IS FULLY SET-UP.

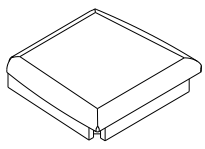

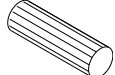
PART LISTS FOR ONE				HARDWARE LISTS FOR ONE			
NO.	DESCRIPTION	SKETCH	Q'TY	NO.	DESCRIPTION	SKETCH	Q'TY
A	CHAIR BACK		1PC	1	BOLT(M6X65mm)		8PCS
B	FRONT LEGS		2PCS	2	BOLT(M6X35mm)		2PCS
				3	Spring washer (6.5/11mm)		10PCS
C	SEAT FRAME		1PC	4	Flat washer (6.5/19mm)		10PCS
				5	ALLEN KEY		1PC
				6	POSITIONING PIN		1PC

ASSEMBLY INSTRUCTIONS

STEP 1:

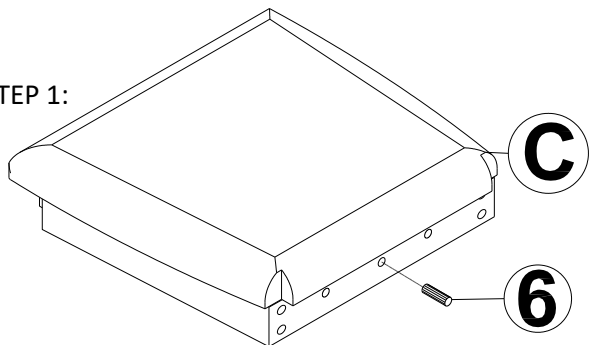

STEP 2:

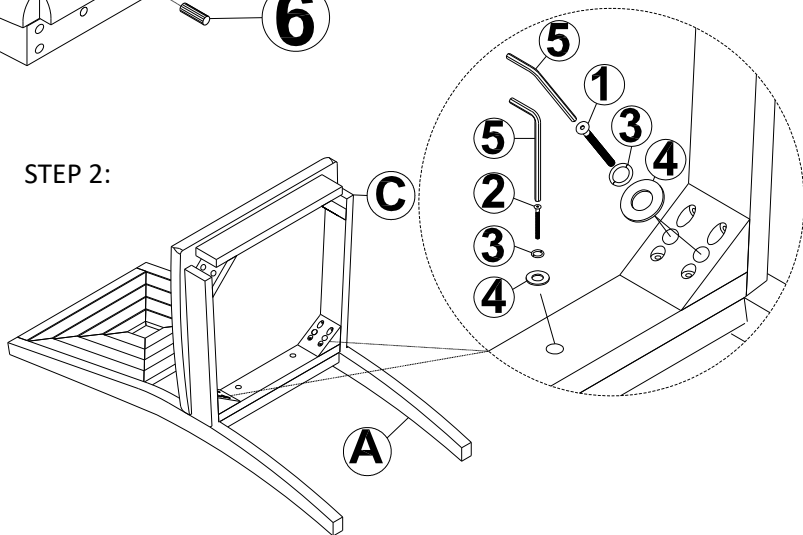

STEP 3:

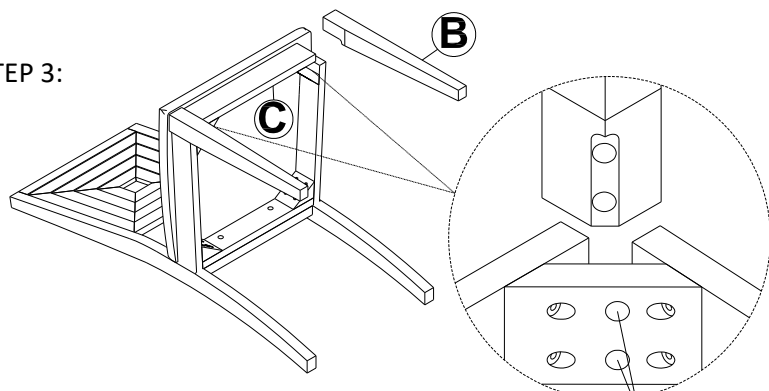

STEP 4:

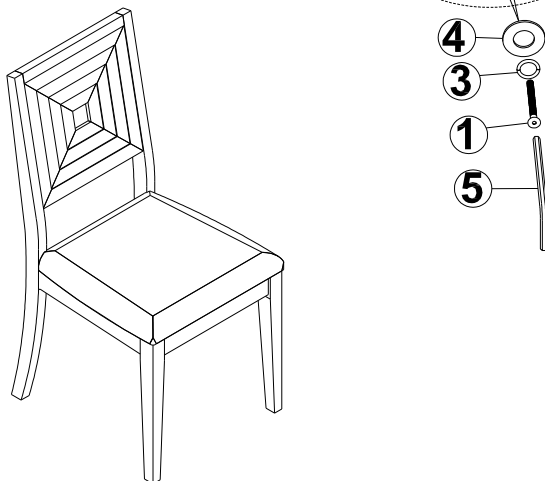

ASSEMBLY INSTRUCTIONS

WF317802 - DINING BENCH

IMPORTANT NOTE :

** PLACE ALL PARTS ON A CLEAN AND SMOOTH SURFACE SUCH AS A RUG OR CARPET TO AVOID THE PARTS FROM BEING SCRATCHED.





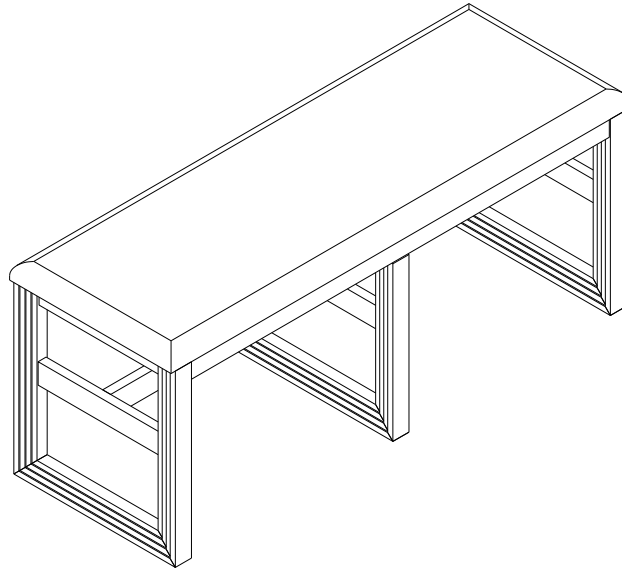



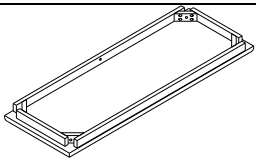

** BEFORE YOU BEGIN, KINDLY FOLLOW THE ASSEMBLY INSTRUCTIONS STEP BY STEP.

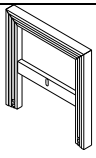
**DO NOT TIGHTEN ALL SCREWS AND BOLTS UNTIL THE DINING BENCH IS FULLY SET-UP.

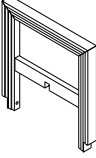

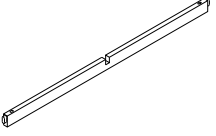
PART LISTS FOR ONE

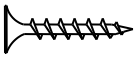
HARDWARE LISTS FOR ONE

NO.	DESCRIPTION	SKETCH	Q'TY	NO.	DESCRIPTION	SKETCH	Q'TY
A	BENCH TOP		1PC	1	BOLT(M6X65mm)		4PCS
B	LEG (L-R)		2PCS	2	Spring washer (6.5/11mm)		4PCS
C	LEG CENTER		1PC	3	Flat washer (6.5/19mm)		4PCS
D	CROSSBAR		1PC	4	ALLEN KEY		1PC
				5	Screw (M4 x 35mm)		3PCS
				6	BOLT(M6X35mm)		2PCS

ASSEMBLY INSTRUCTIONS

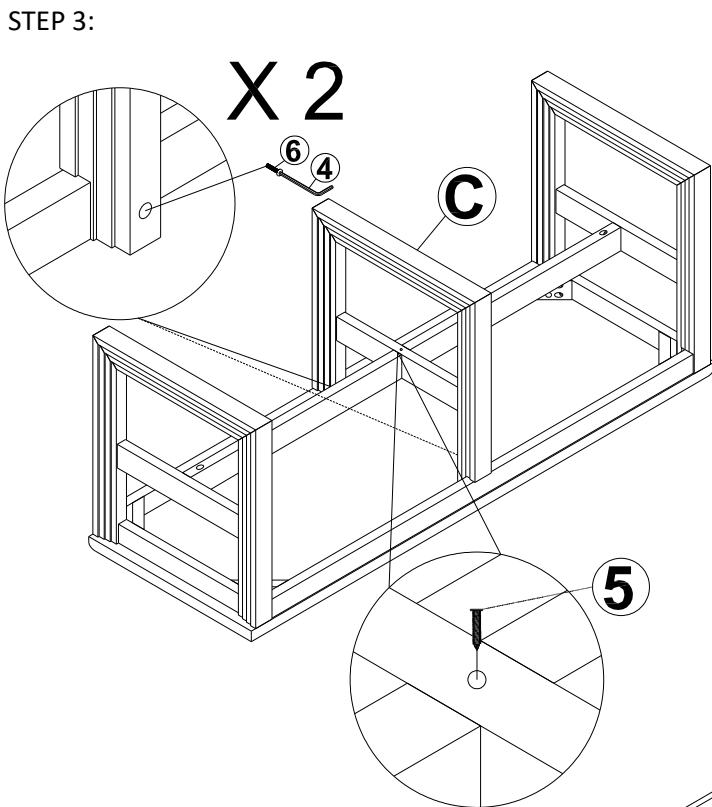
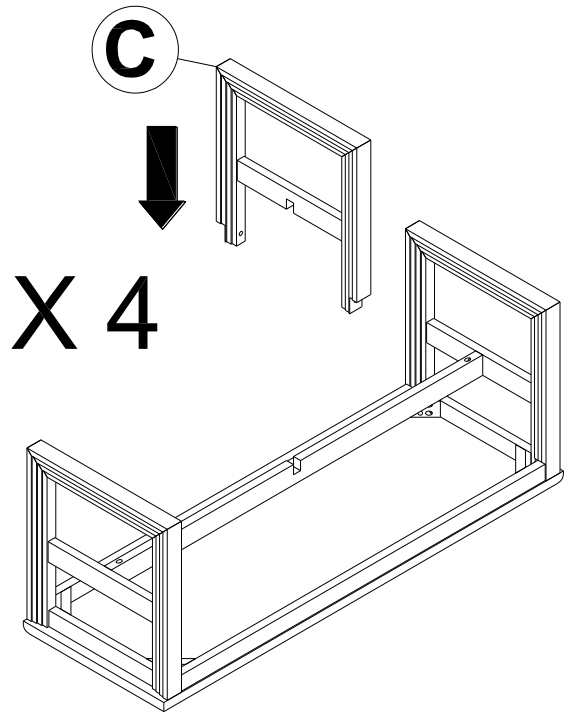
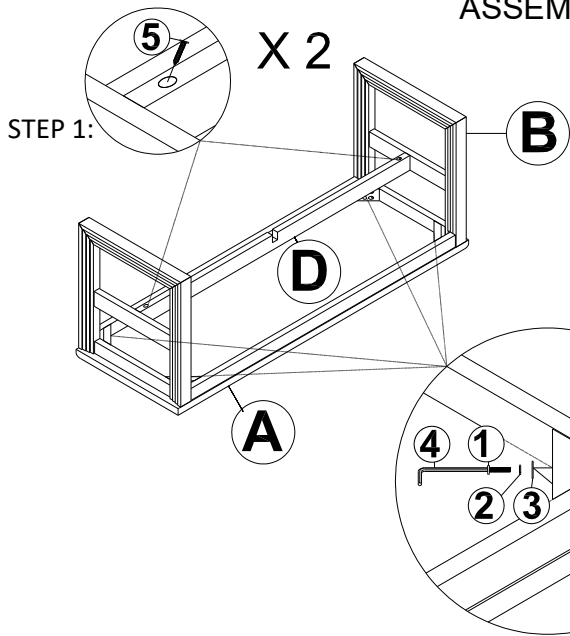

STEP 4:

