

# ASSEMBLY INSTRUCTIONS

WF317798 - DINING TABLE

## IMPORTANT NOTE :





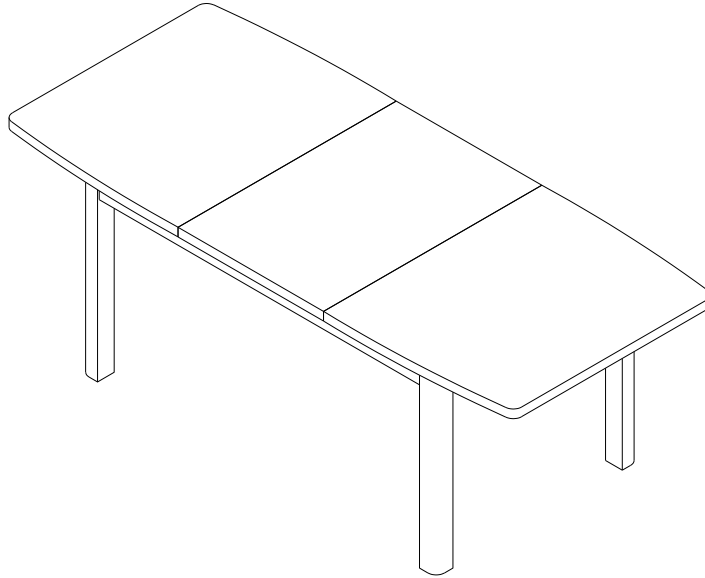

\*\* PLACE ALL PARTS ON A CLEAN AND SMOOTH SURFACE SUCH AS A RUG OR CARPET TO AVOID THE PARTS FROM BEING SCRATCHED.

\*\* BEFORE YOU BEGIN, KINDLY FOLLOW THE ASSEMBLY INSTRUCTIONS STEP BY STEP.

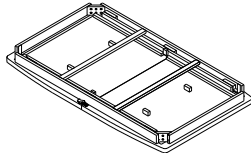
\*\*DO NOT TIGHTEN ALL SCREWS AND BOLTS UNTIL THE DINING TABLE IS FULLY SET-UP.

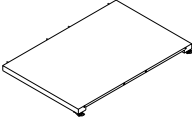

CARTONS ONLY ONE/ CARTONS SEULEMENT UN

PART LISTS				HARDWARE LISTS			
NO.	DESCRIPTION	SKETCH	Q'TY	NO.	DESCRIPTION	SKETCH	Q'TY
A	TABLE TOP		1PC	1	BOLT(M8X60mm)		8PCS
B	LEGS		4PCS	2	Spring washer (8.5/11mm)		8PCS
C	TABLE LEAF		1PC	3	Flat washer (8.5/19mm)		8PCS
				4	ALLEN KEY		1PC

# ASSEMBLY INSTRUCTIONS

STEP 1:

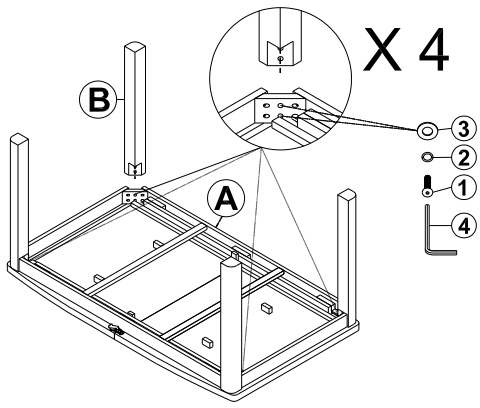

STEP 2:

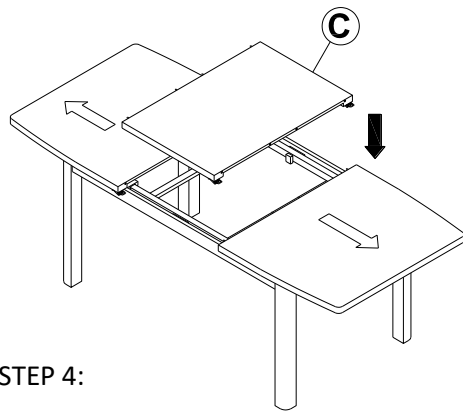

STEP 3:

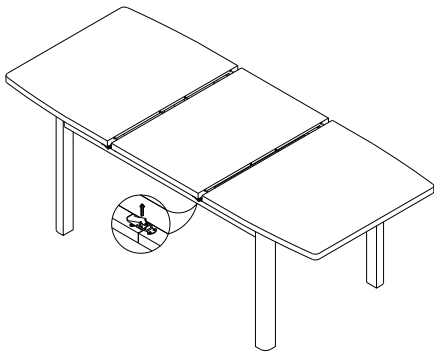

STEP 4:

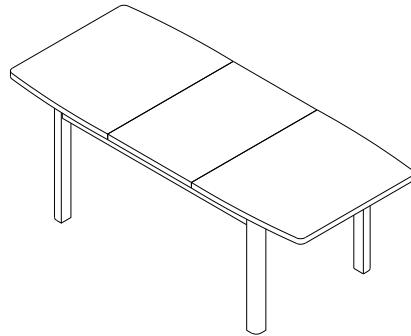

STEP 5:

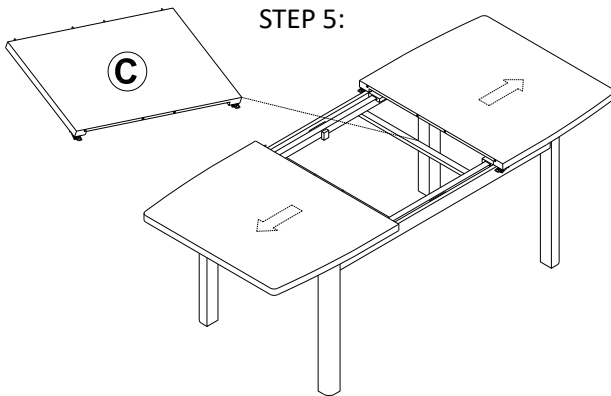

STEP 6:

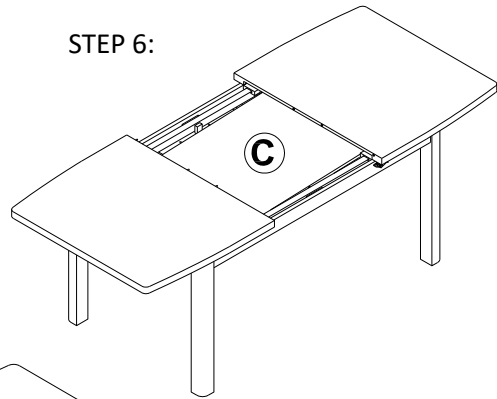

STEP 7:

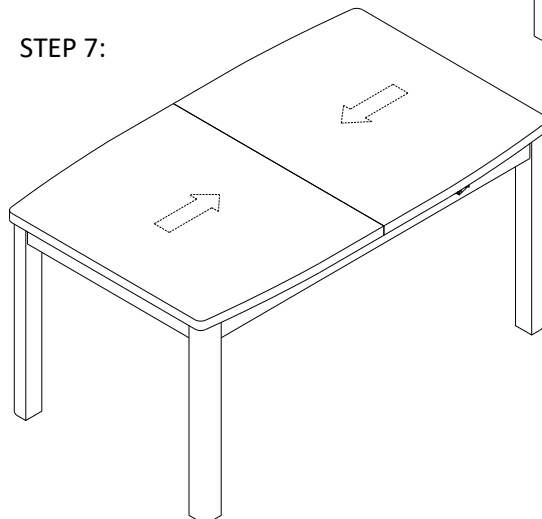

# ASSEMBLY INSTRUCTIONS

WF317799 – ARMLESS CHAIRS







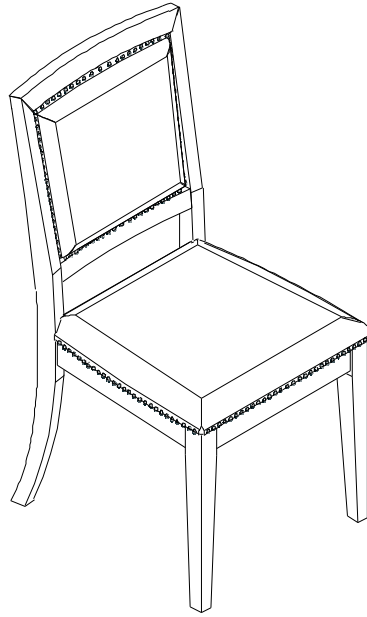

## IMPORTANT NOTE :

\*\* PLACE ALL PARTS ON A CLEAN AND SMOOTH SURFACE SUCH AS A RUG OR CARPET TO AVOID THE PARTS FROM BEING SCRATCHED.

\*\* BEFORE YOU BEGIN, KINDLY FOLLOW THE ASSEMBLY INSTRUCTIONS STEP BY STEP.

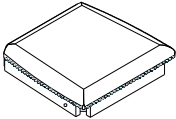
\*\*DO NOT TIGHTEN ALL SCREWS AND BOLTS UNTIL THE ARMLESS CHAIR IS FULLY SET-UP.

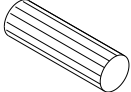

PART LISTS FOR ONE				HARDWARE LISTS FOR ONE			
NO.	DESCRIPTION	SKETCH	Q'TY	NO.	DESCRIPTION	SKETCH	Q'TY
A	CHAIR BACK		1PC	1	BOLT(M6X65mm)		8PCS
B	FRONT LEGS		2PCS	2	BOLT(M6X35mm)		2PCS
C	SEAT FRAME		1PC	3	Spring washer (6.5/11mm)		10PCS
				4	Flat washer (6.5/19mm)		10PCS
				5	ALLEN KEY		1PC
				6	POSITIONING PIN		1PC

# ASSEMBLY INSTRUCTIONS

STEP 1:

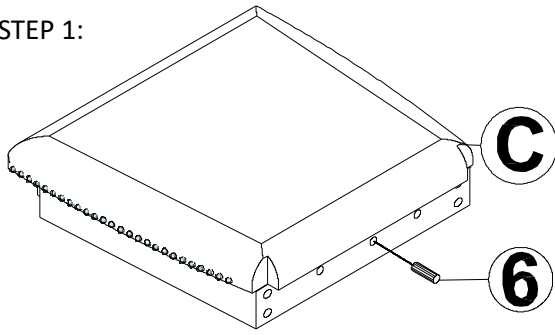

STEP 2:

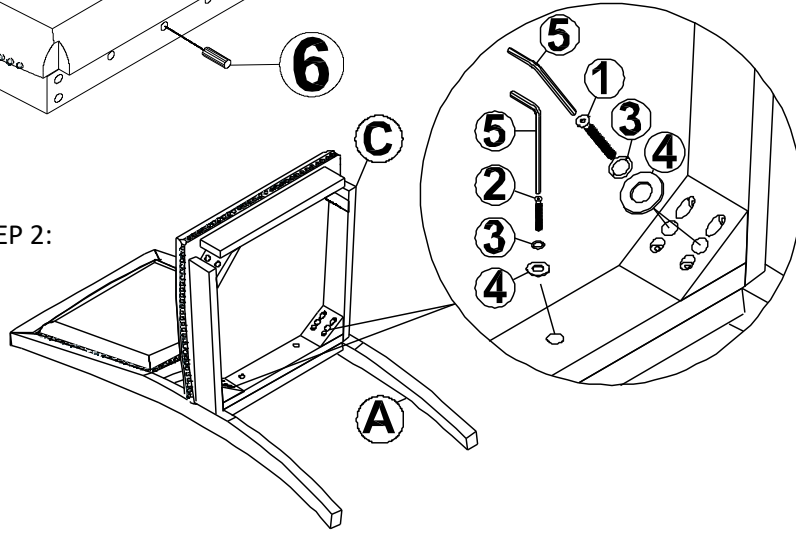

X 2

STEP 3:

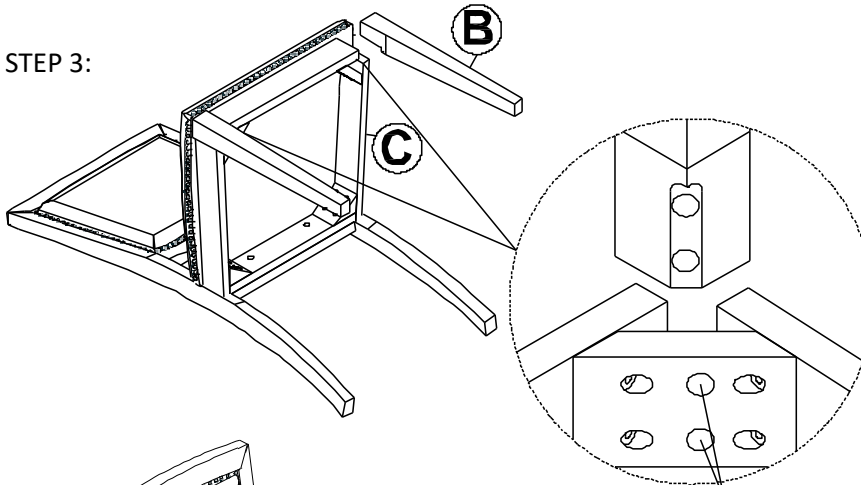

X 2

STEP 4:

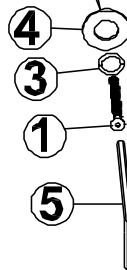
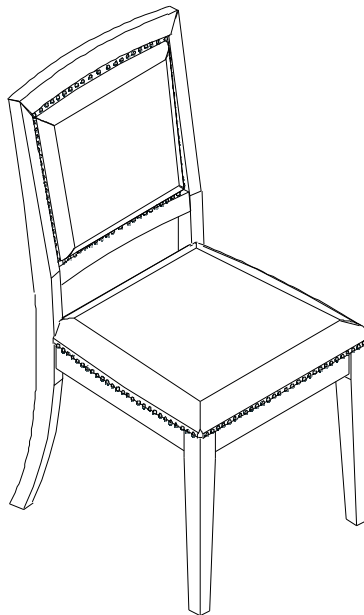

# ASSEMBLY INSTRUCTIONS

WF317799 – ARM CHAIRS

## IMPORTANT NOTE :

\*\* PLACE ALL PARTS ON A CLEAN AND SMOOTH SURFACE SUCH AS A RUG OR CARPET TO AVOID THE PARTS FROM BEING SCRATCHED.





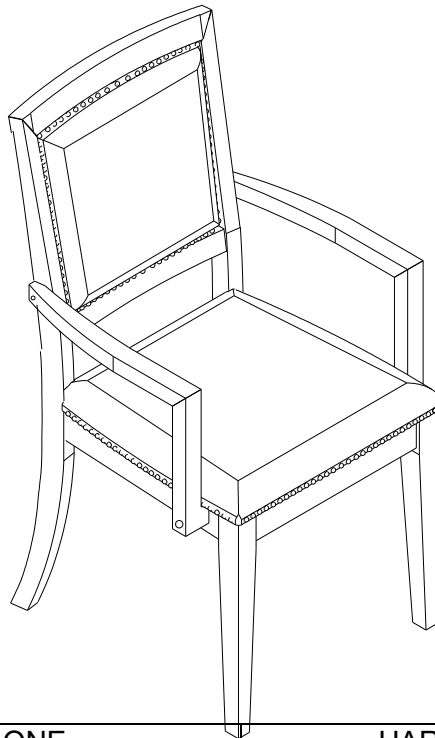



\*\* BEFORE YOU BEGIN, KINDLY FOLLOW THE ASSEMBLY INSTRUCTIONS STEP BY STEP.

\*\*DO NOT TIGHTEN ALL SCREWS AND BOLTS UNTIL THE ARM CHAIR IS FULLY SET-UP.

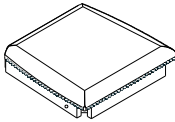

### PART LISTS FOR ONE

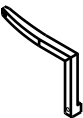
### HARDWARE LISTS FOR ONE

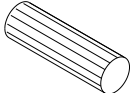
NO.	DESCRIPTION	SKETCH	Q'TY	NO.	DESCRIPTION	SKETCH	Q'TY
A	CHAIR BACK		1PC	1	BOLT(M6X65mm)		8PCS
B	FRONT LEGS		2PCS	2	BOLT(M6X35mm)		6PCS
C	SEAT FRAME		1PC	3	SPRING WASHER (6.5/11mm)		10PCS
D	ARM (L/R)		2PCS	4	FLAT WASHER (6.5/19mm)		10PCS
				5	ALLEN KEY		1PC
				6	POSITIONING PIN		1PC

# ASSEMBLY INSTRUCTIONS

STEP 1:

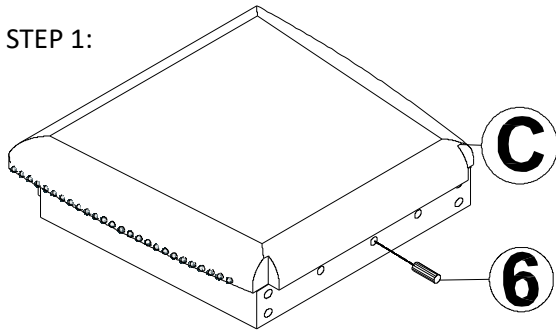

STEP 2:

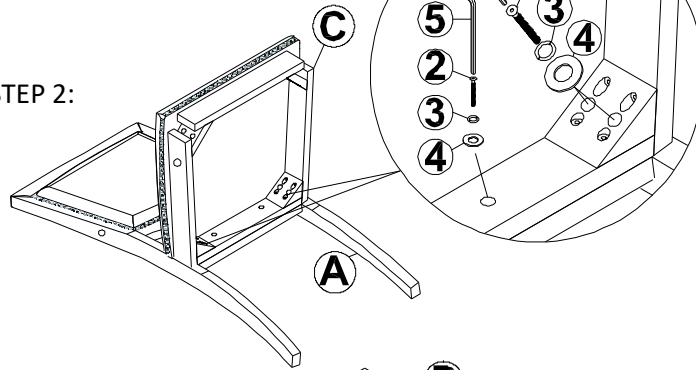

X 2

STEP 3:

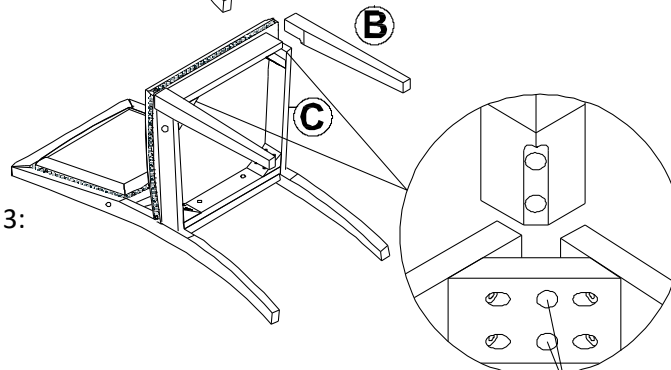

X 2

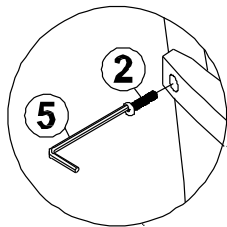

X 2

STEP 4:

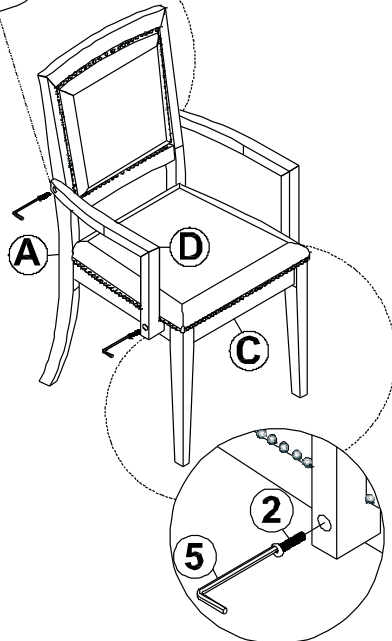

STEP 5:

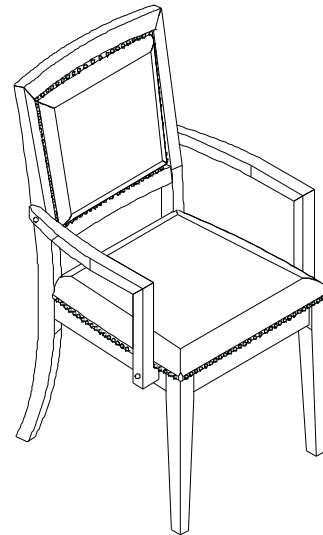

X 2