

# ASSEMBLY INSTRUCTIONS

ITEM NO. WF309784- DINING TABLE

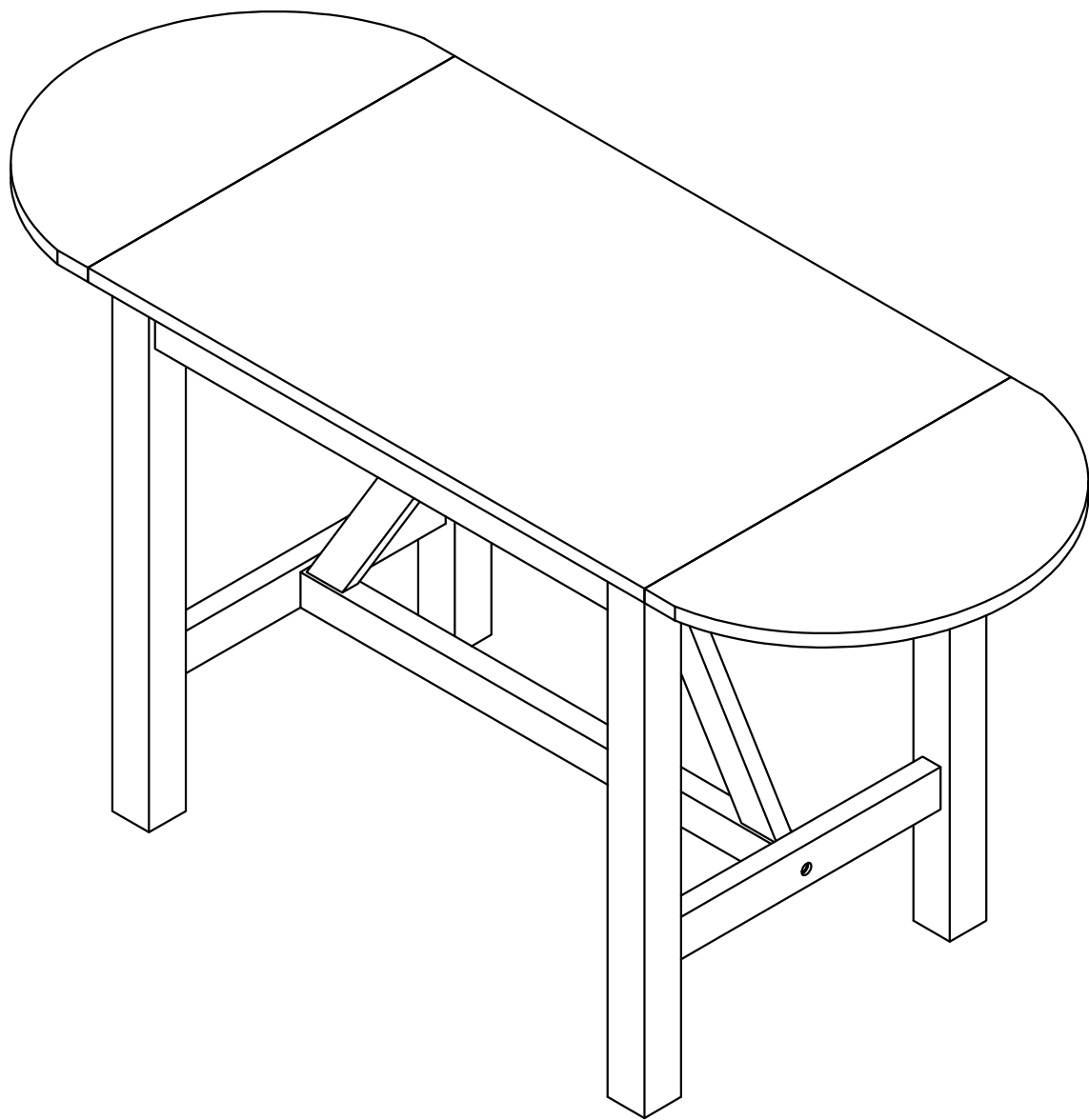





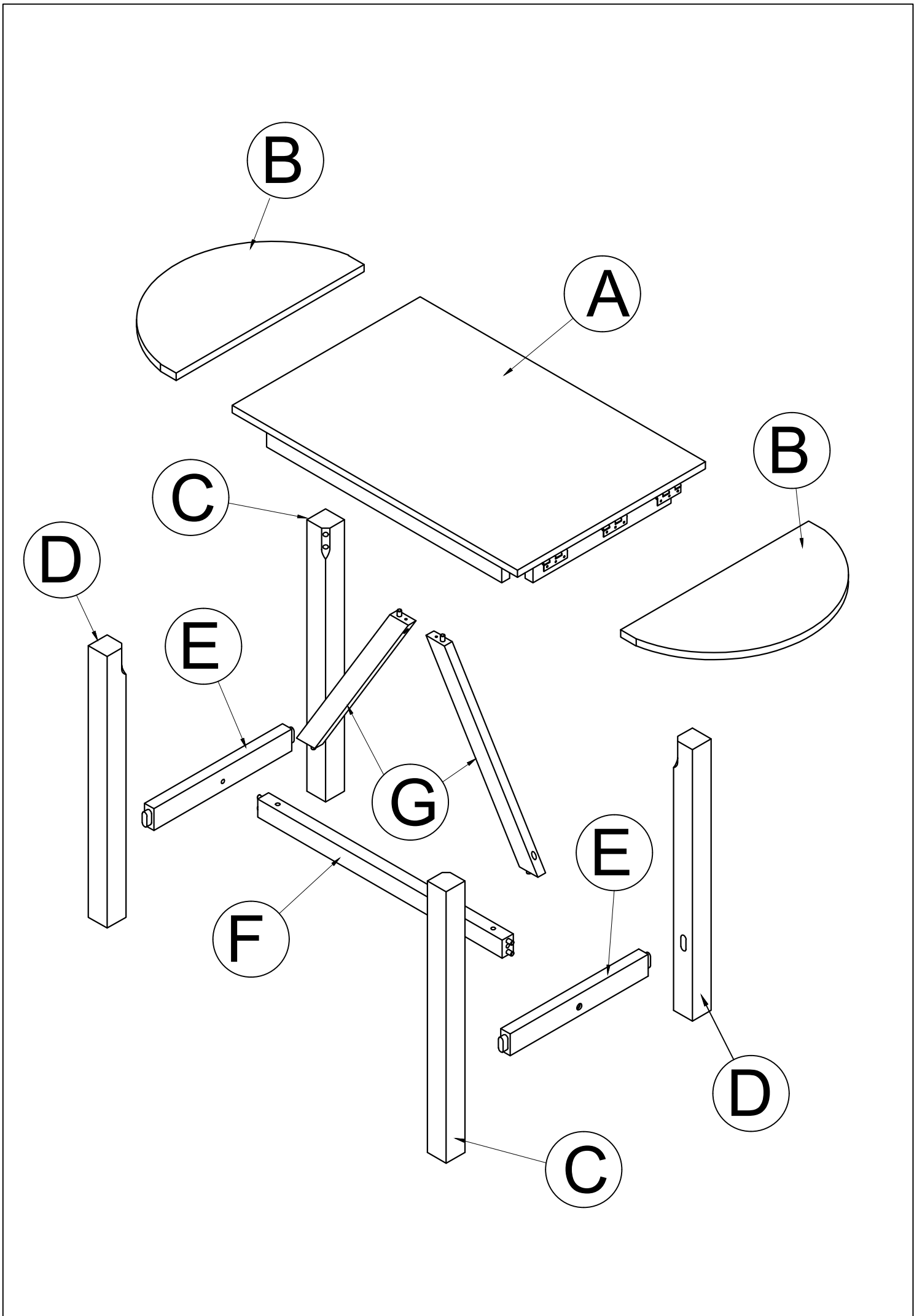

## IMPORTANT NOTE:

- ① PLACE ALL PARTS ON A CLEAN AND SMOOTH SURFACE SUCH AS A RUG OR CARPET TO AVOID THE PARTS FROM BEING SCRATCHED.
- ② BEFORE YOU BEGIN, KINDLY FOLLOW THE ASSEMBLY INSTRUCTIONS STEP BY STEP.
- ③ DO NOT TIGHTEN ALL SCREWS AND BOLTS UNTIL THE CHAIR IS FULLY SET-UP.

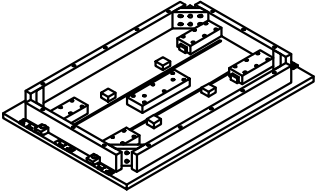
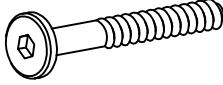
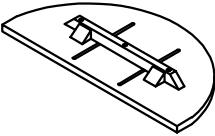
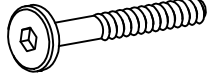
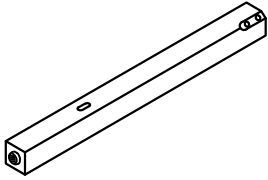

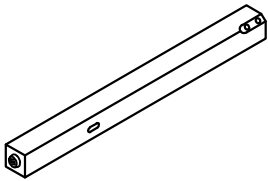
# Part List

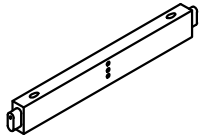
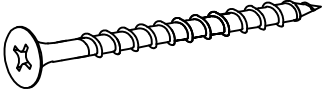
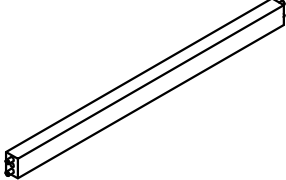
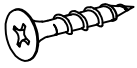
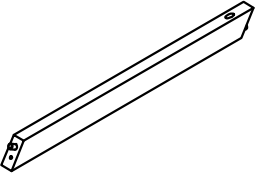
# Hardware List

<p>(A)</p>  <p>TOP PANEL (1 PC)</p>	<p>(1)</p>  <p>Ø 5/16" x 60mm</p> <p>BOLT ( 8 pcs)</p>
<p>(B)</p>  <p>SIDE PANEL (2 PCS)</p>	<p>(2)</p>  <p>Ø 5/16" x 40mm</p> <p>BOLT ( 2 pcs)</p>
<p>(C)</p>  <p>LEFT LEG (2 PCS)</p>	<p>(3)</p>  <p>Ø 5/16" x 13mm</p> <p>FLAT WASHER ( 8 pcs)</p>
<p>(D)</p>  <p>RIGHT LEG (2 PCS)</p>	<p>(4)</p>  <p>Ø 5/16" x 19mm</p> <p>LOCK WASHER ( 8 pcs)</p>
<p>(E)</p>  <p>SIDE RAIL (2 PCS)</p>	<p>(5)</p>  <p>M4 x 45mm</p> <p>SCREW ( 8 pcs)</p>
<p>(F)</p>  <p>MIDDLE RAIL (1 PC)</p>	<p>(6)</p>  <p>M3.5 x 15mm</p> <p>SCREW ( 18 pcs)</p>
<p>(G)</p>  <p>TOP RAIL (2 PCS)</p>	<p>(7)</p>  <p>4mm</p> <p>ALLEN KEY ( 1 pc)</p>

# STEP 1:

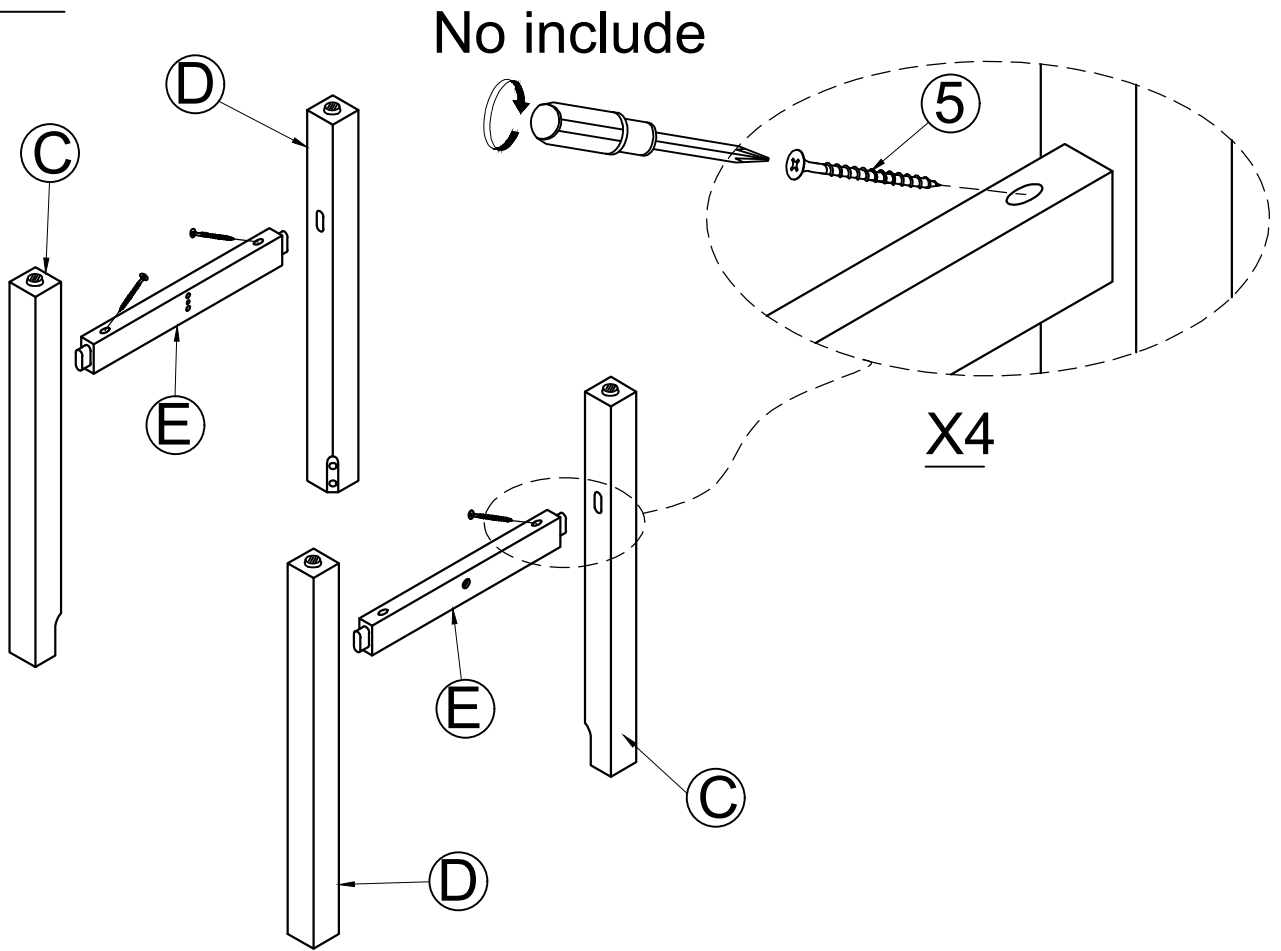

# STEP 2:

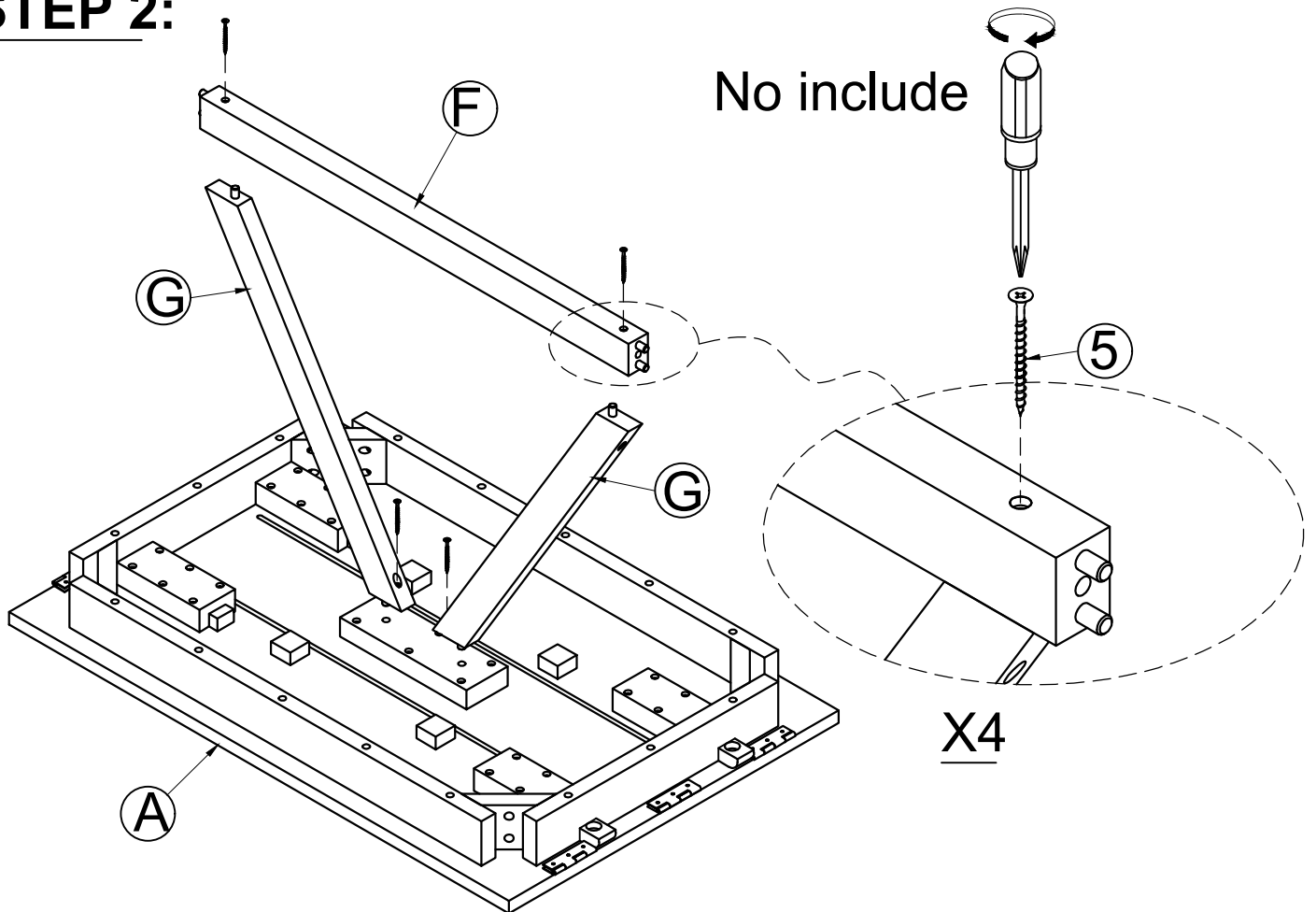

### STEP 3:

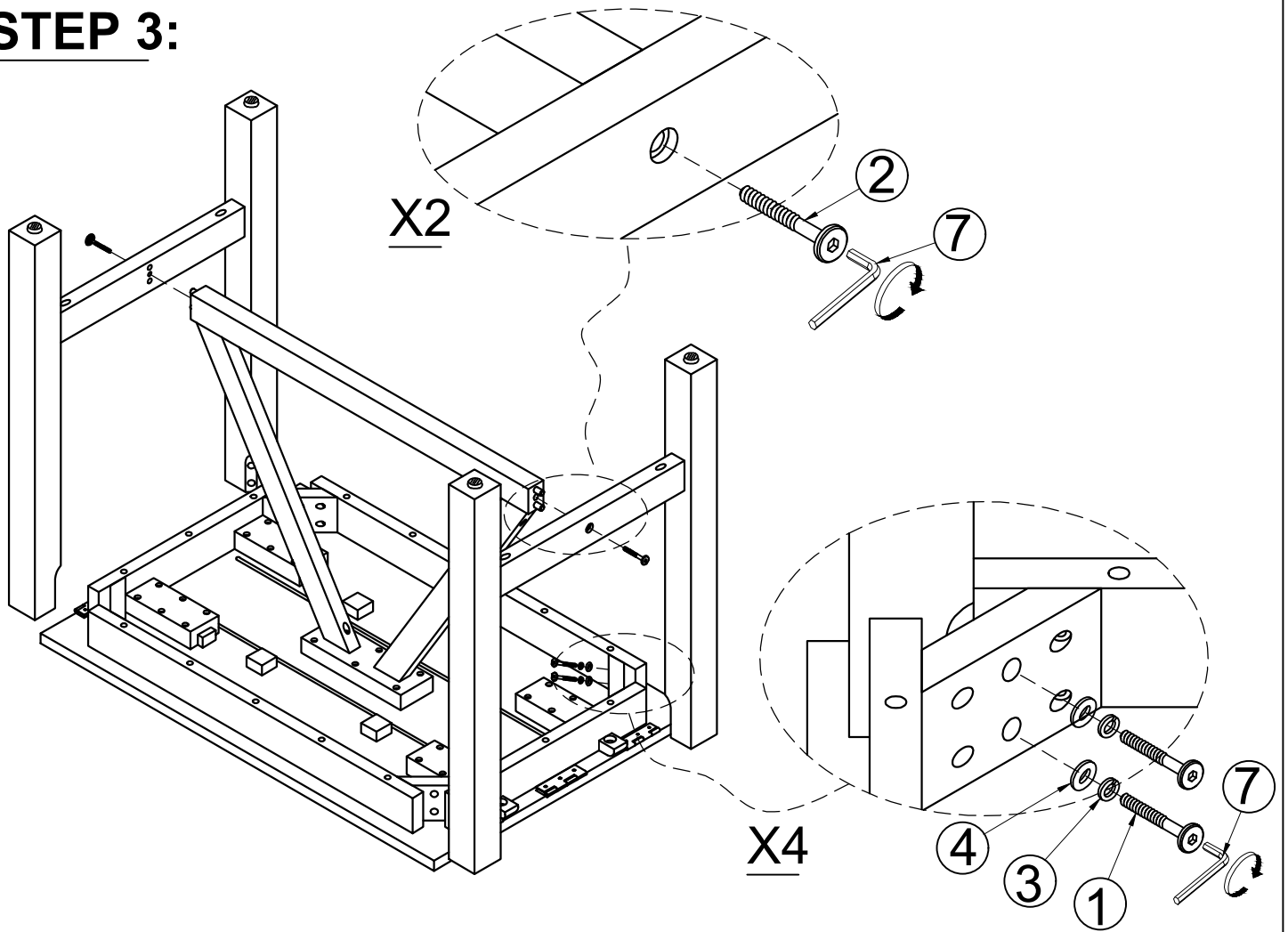

### STEP 4:

No include

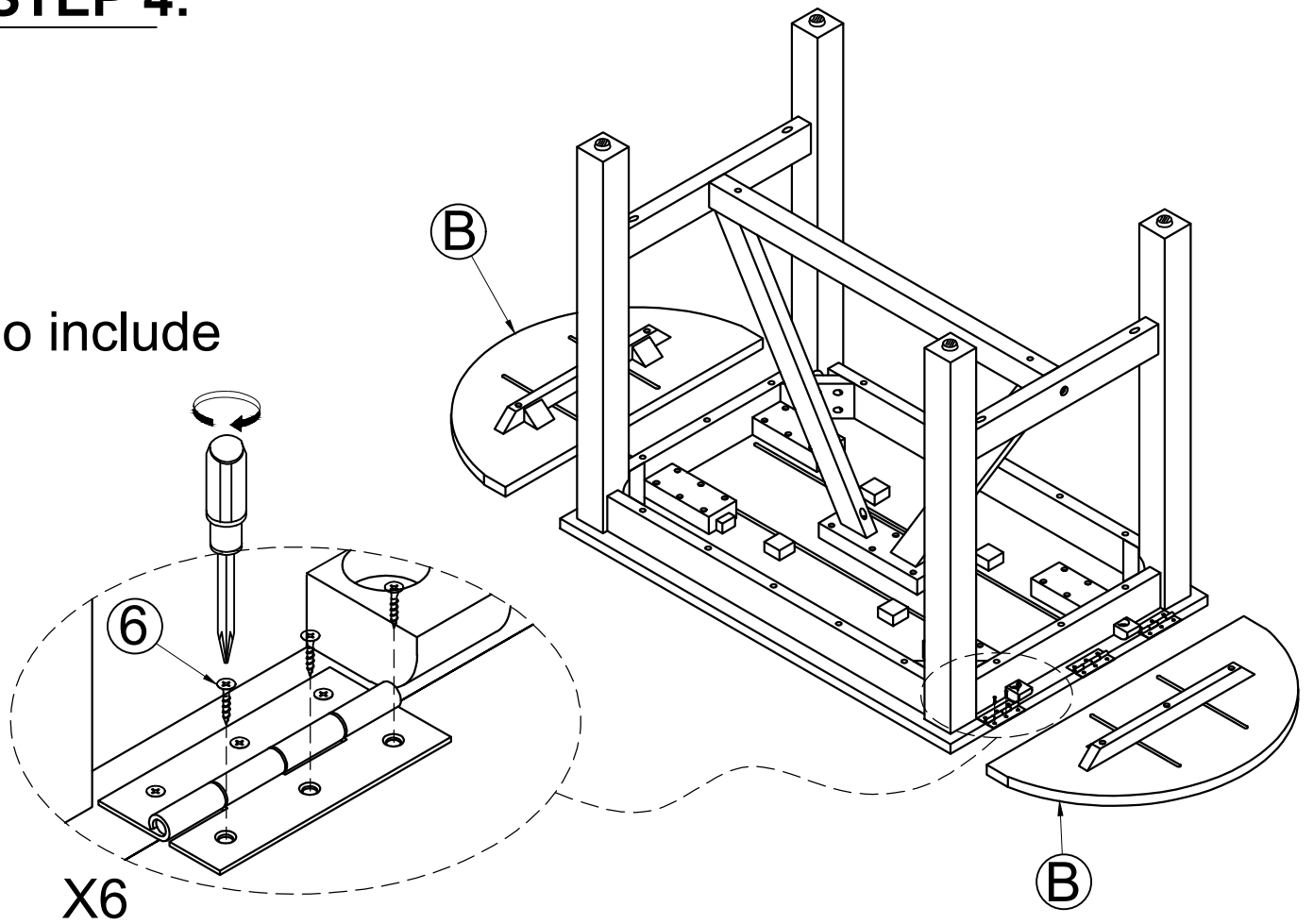

**STEP 5:**

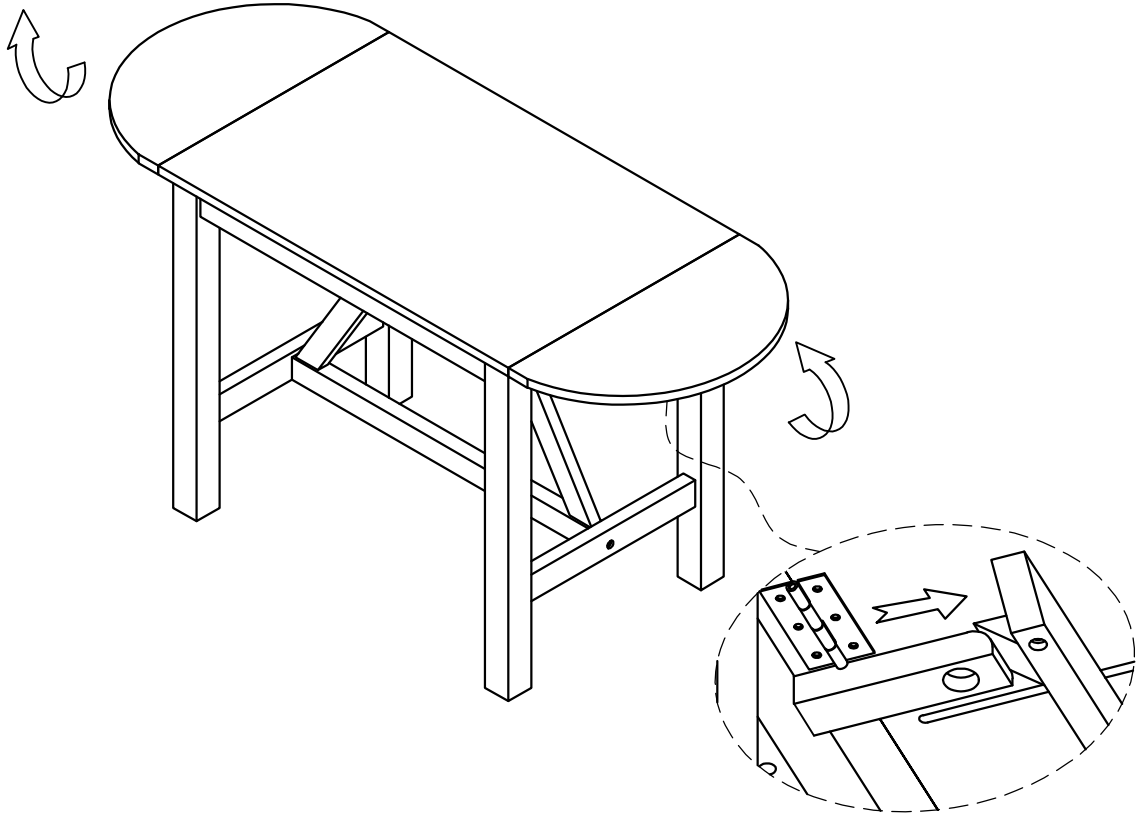

**STEP 6:**

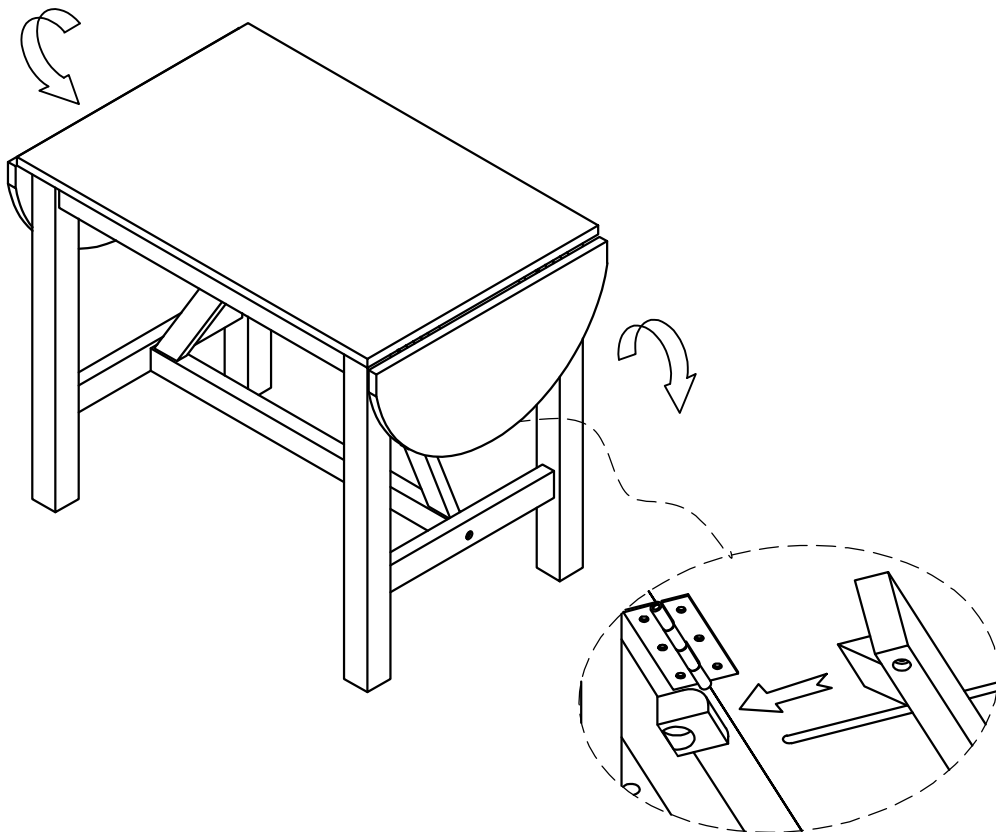

# ASSEMBLY INSTRUCTIONS

ITEM NO. WF309785 - DINING CHAIR

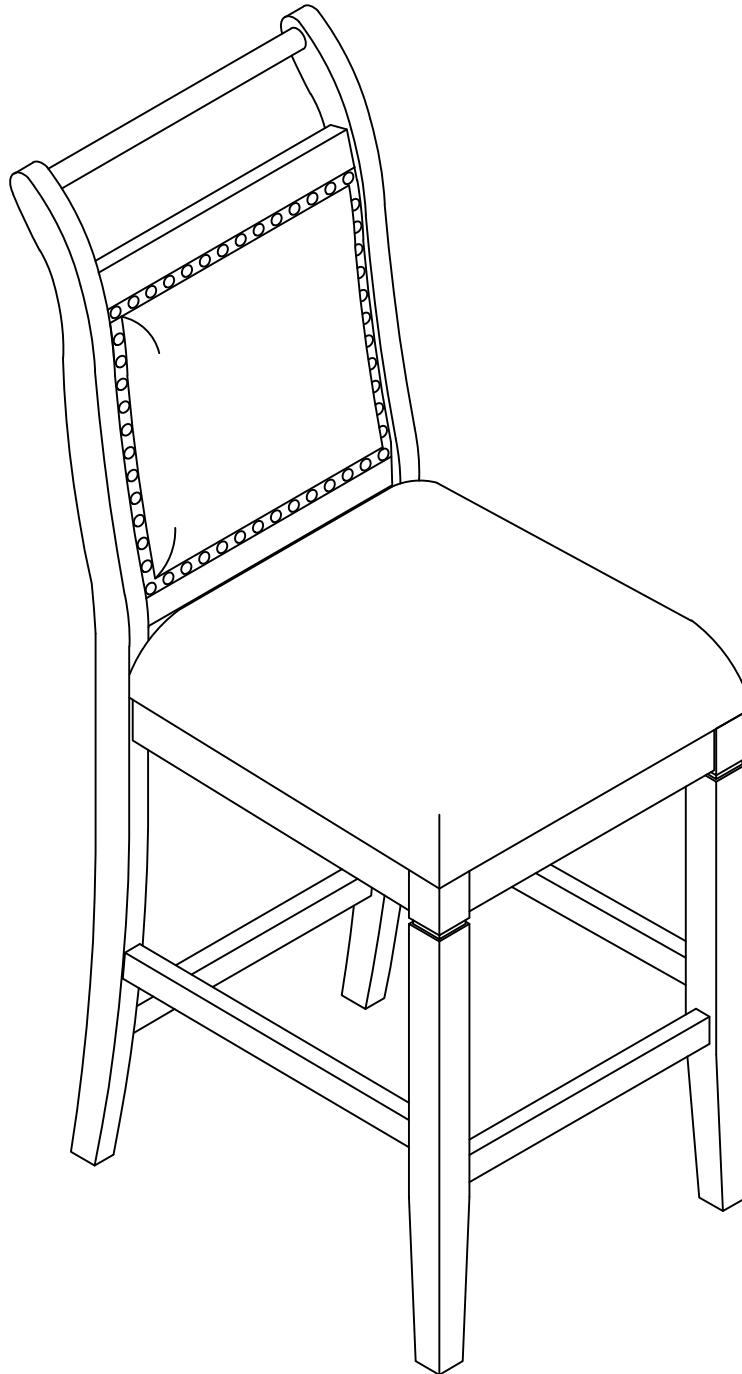

## IMPORTANT NOTE:



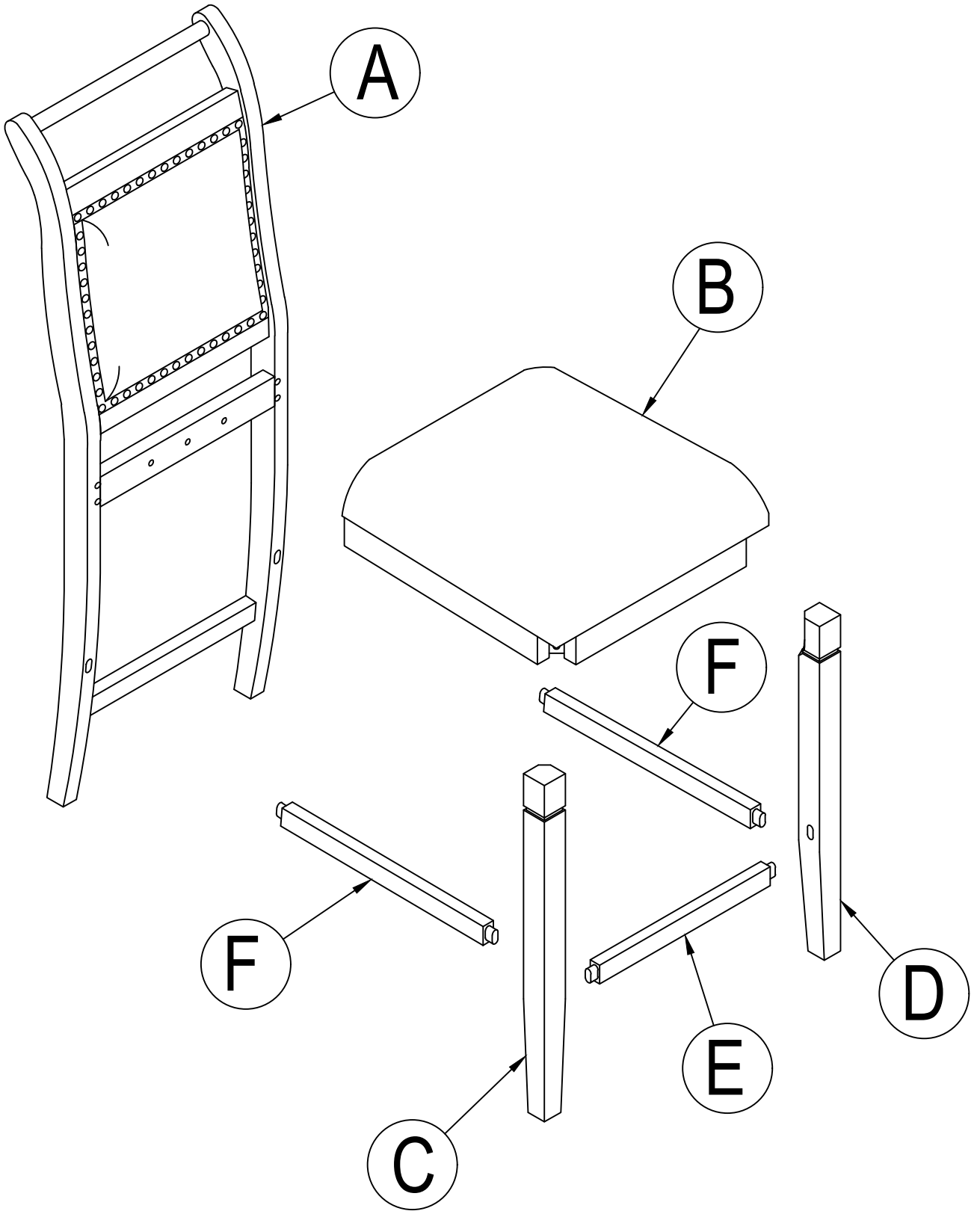

- ① PLACE ALL PARTS ON A CLEAN AND SMOOTH SURF ACE SUCH AS A RUG OR CARPET TO AVOID THE PARTS FROM BEING SCRATCHED.
- ② BEFORE TOU BEGIN, KINDLKY FOLLOW THE ASSEBLY INSTRUCTIONS STEP BY.
- ③ DO NOT TIGHTEN ALL SCREWS AND BOLTS UNTIL THE CHAIR IS FULLY SET-UP.



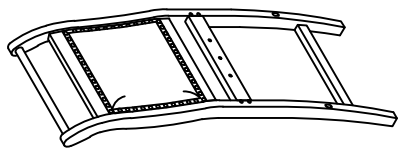
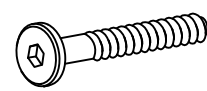
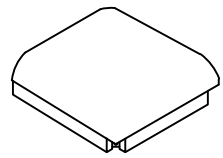
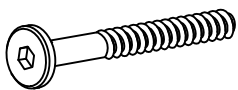
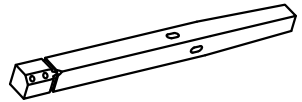
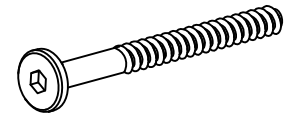
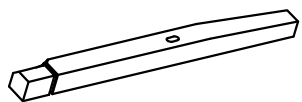

# Part List For One

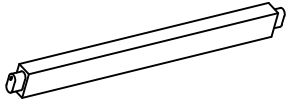
# Hardware List For One

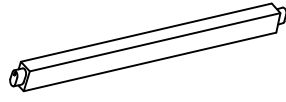
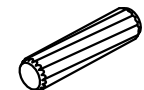
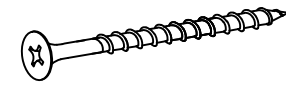
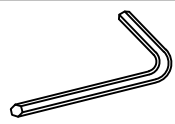
<p>(A)</p>  <p>CHAIR BACK (1 PC)</p>	<p>(1)</p>  <p>Ø 1/4" x 40mm BOLT ( 2 pcs)</p>
<p>(B)</p>  <p>CUSHION SEAT (1 PC)</p>	<p>(2)</p>  <p>Ø 1/4" x 60mm BOLT ( 4 pcs)</p>
<p>(C)</p>  <p>FRONT LEFT LEG (1 PC)</p>	<p>(3)</p>  <p>Ø 1/4" x 85mm BOLT ( 4 pcs)</p>
<p>(D)</p>  <p>FRONT RIGHT LEG (1 PC)</p>	<p>(4)</p>  <p>Ø 1/4" x 13mm FLAT WASHER ( 10 pcs)</p>
<p>(E)</p>  <p>FRONT STRETCHER (1 PC)</p>	<p>(5)</p>  <p>Ø 1/4" x 19mm LOCK WASHER ( 10 pcs)</p>
<p>(F)</p>  <p>SIDE STRETCHER (2 PCS)</p>	<p>(6)</p>  <p>Ø 10 x 30mm WOOD DOWEL ( 1 pc)</p>
	<p>(7)</p>  <p>M4 x 40mm SCREW ( 6 pcs)</p>
	<p>(8)</p>  <p>4mm ALLEN KEY ( 1 pc)</p>

# STEP 1:

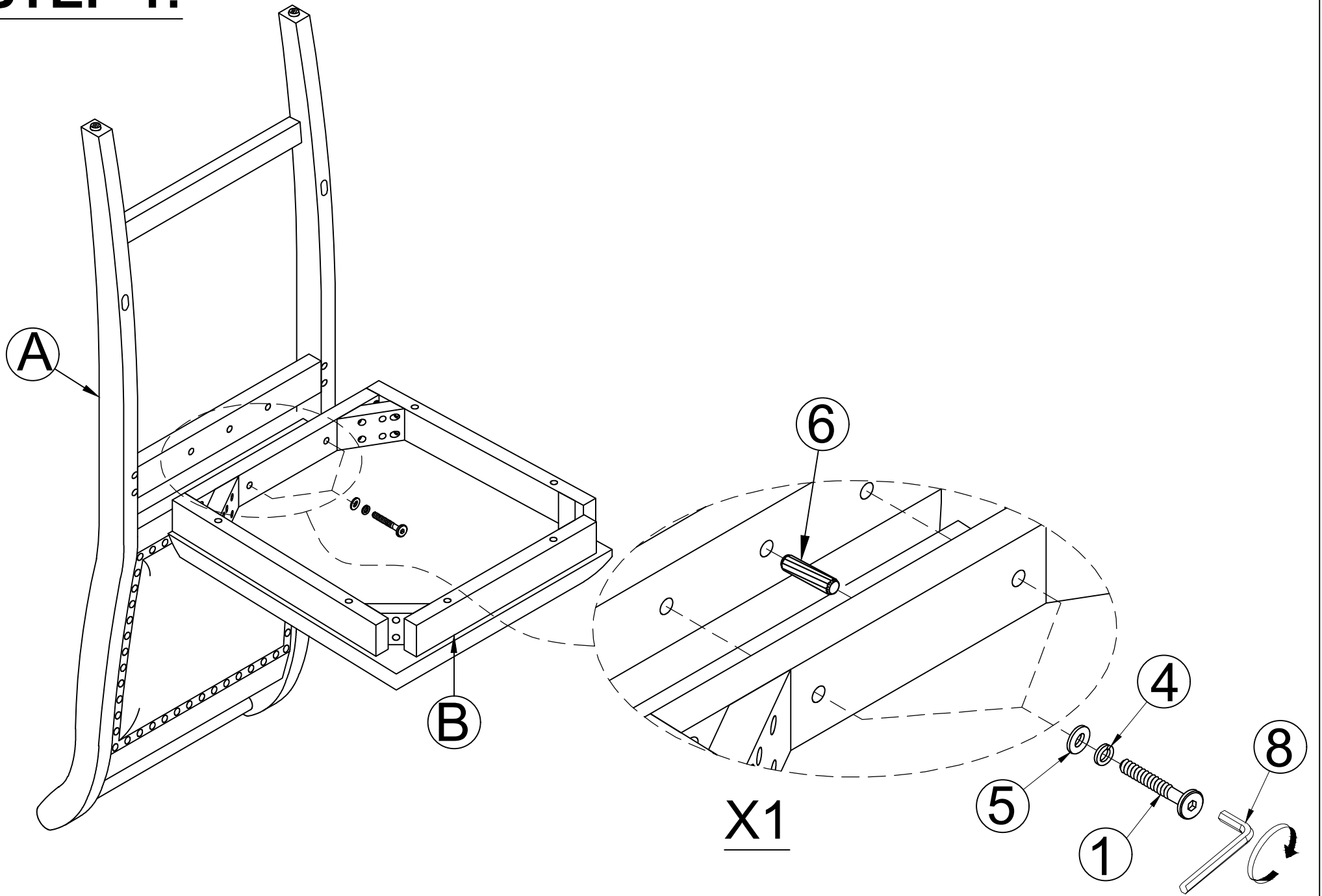

# STEP 2:

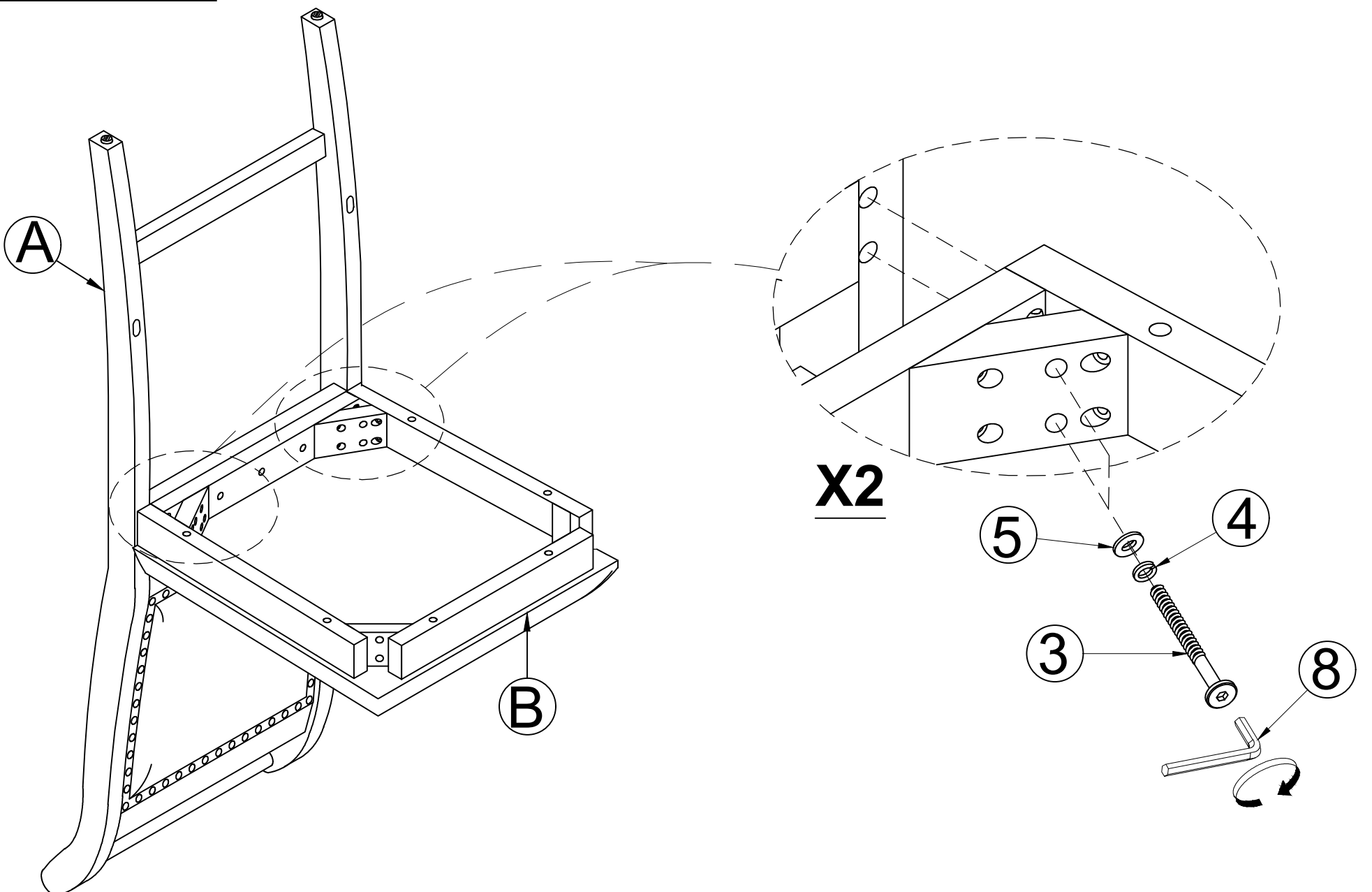

**STEP 3:**

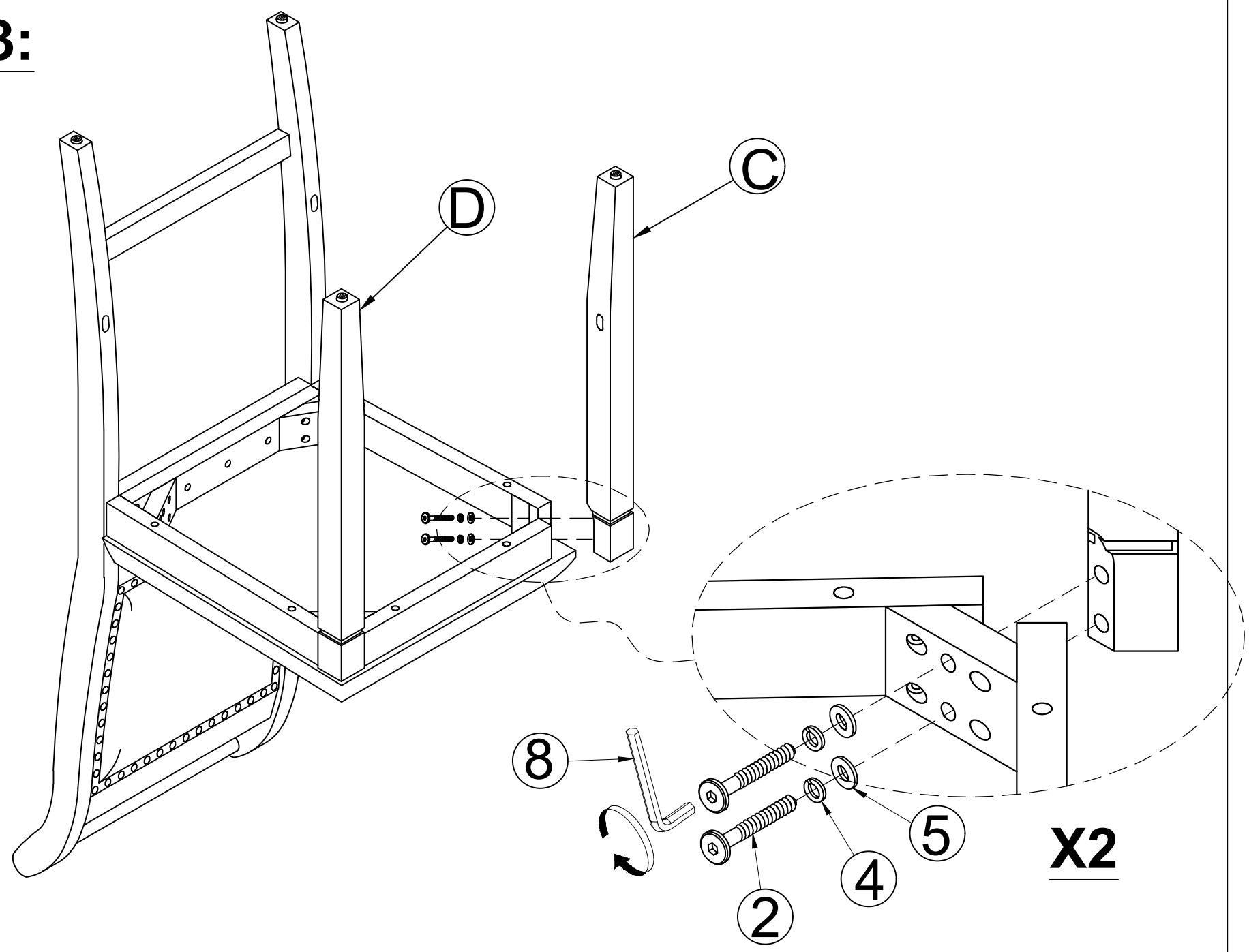

**STEP 4:**

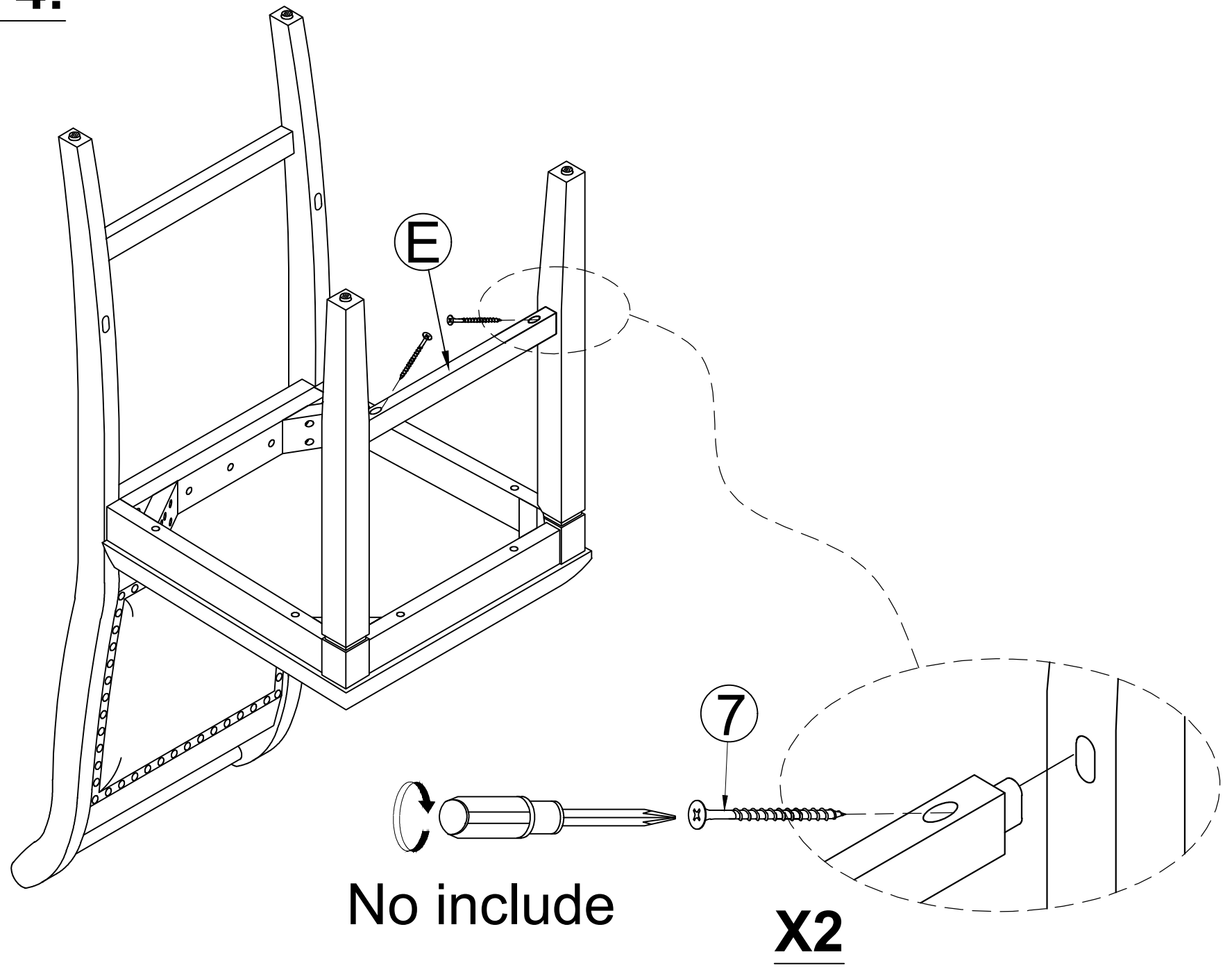

## STEP 5:

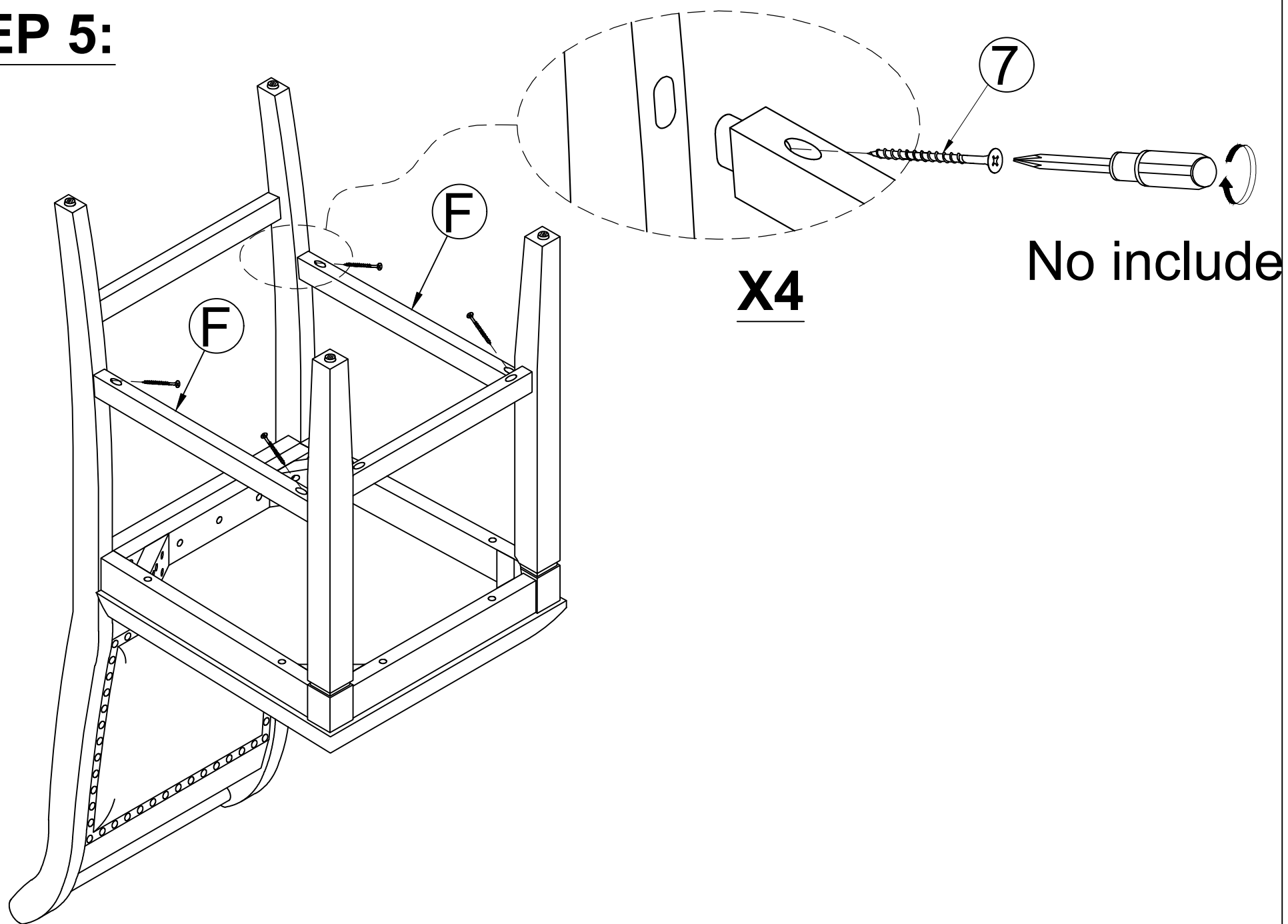

## STEP 6:

