

ASSEMBLY INSTRUCTIONS

ITEM NO.WF312053

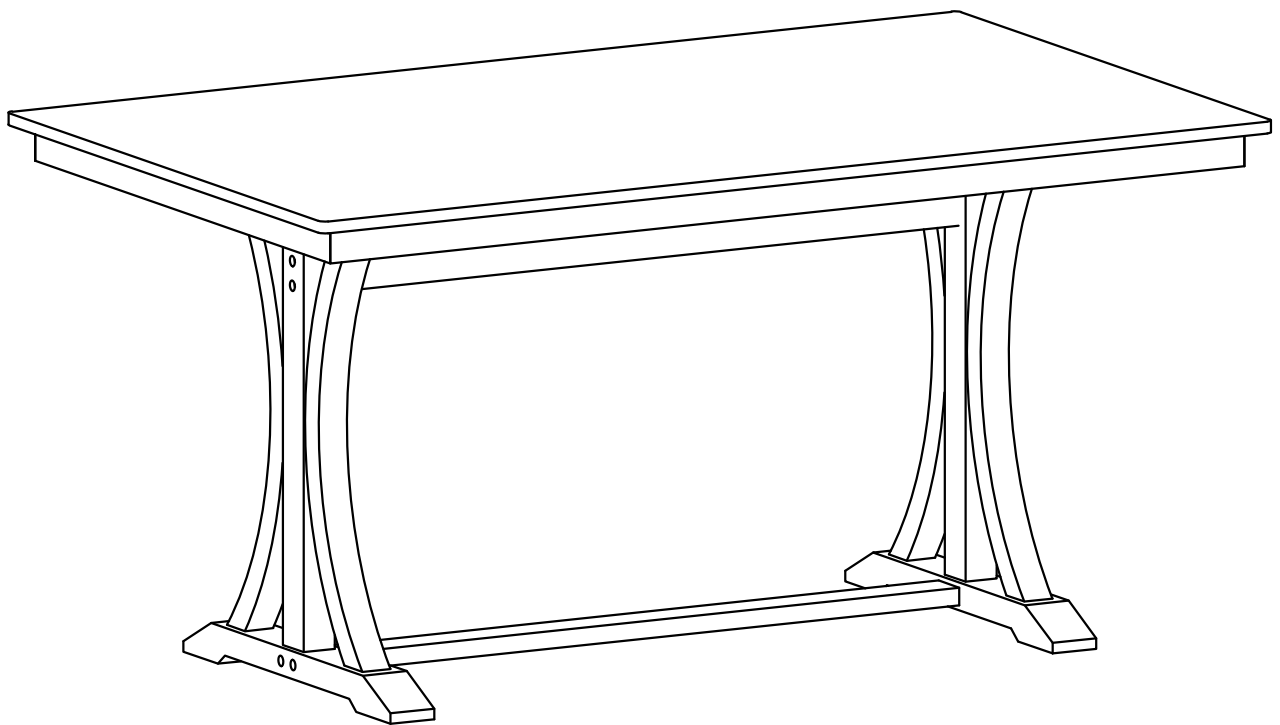



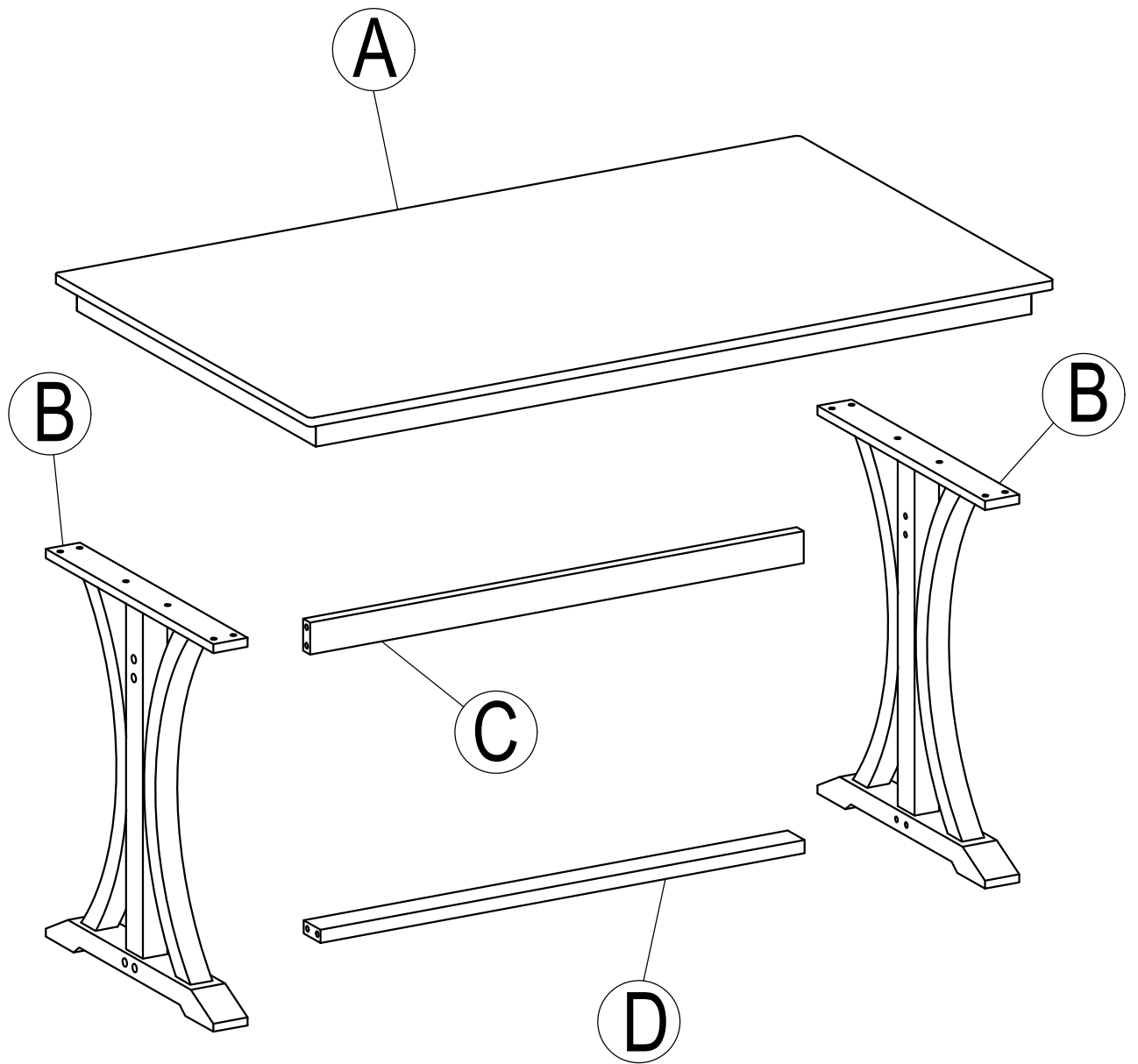

IMPORTANT NOTE :

- ① PLACE ALL PARTS ON A CLEAN AND SMOOTH SURFACE SUCH AS A RUG OR CARPET TO AVOID THE PARTS FROM BEING SCRATCHED.
- ② BEFORE YOU BEGIN,KINDLY FOLLOW THE ASSEMBLY INSTRUCTIONS STEP BY STEP.
- ③ DO NOT TIGHTEN ALL SCREWS AND BOLTS UNTIL THE TABLE IS FULLY SET-UP.

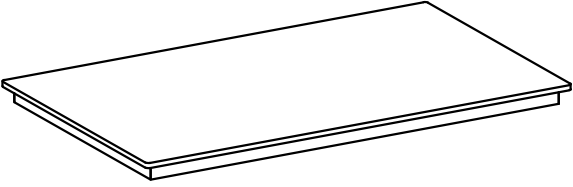
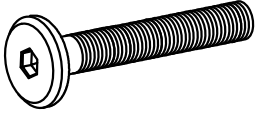
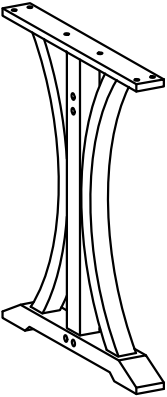
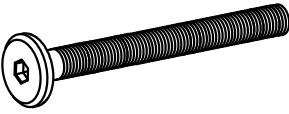
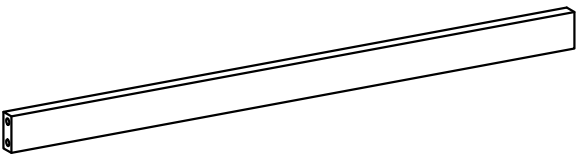

Part List

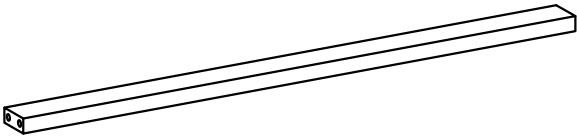
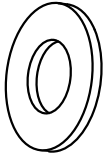
Hardware List

<p>(A)</p> 	<p>(1)</p>  <p>Ø 5/16" x 35 mm</p>
<p>TABLE TOP(1 pc)</p>	<p>BOLT (12 pcs)</p>
<p>(B)</p> 	<p>(2)</p>  <p>Ø 5/16" x 65 mm</p>
<p>TABLE LEG (2 pcs)</p>	<p>BOLT (8 pcs)</p>
<p>(C)</p> 	<p>(3)</p>  <p>Ø5/16" x 13 mm</p>
<p>TOP STRETCHER (1 pc)</p>	<p>FLAT WASHER (20 pcs)</p>
<p>(D)</p> 	<p>(4)</p>  <p>Ø5/16" x 19 mm</p>
<p>BOTTOM STRETCHER (1 pc)</p>	<p>(5)</p>  <p>4 mm</p>
<p>BOTTOM STRETCHER (1 pc)</p>	<p>(6)</p>  <p>WOOD PLUG (8 pcs)</p>

STEP 1:

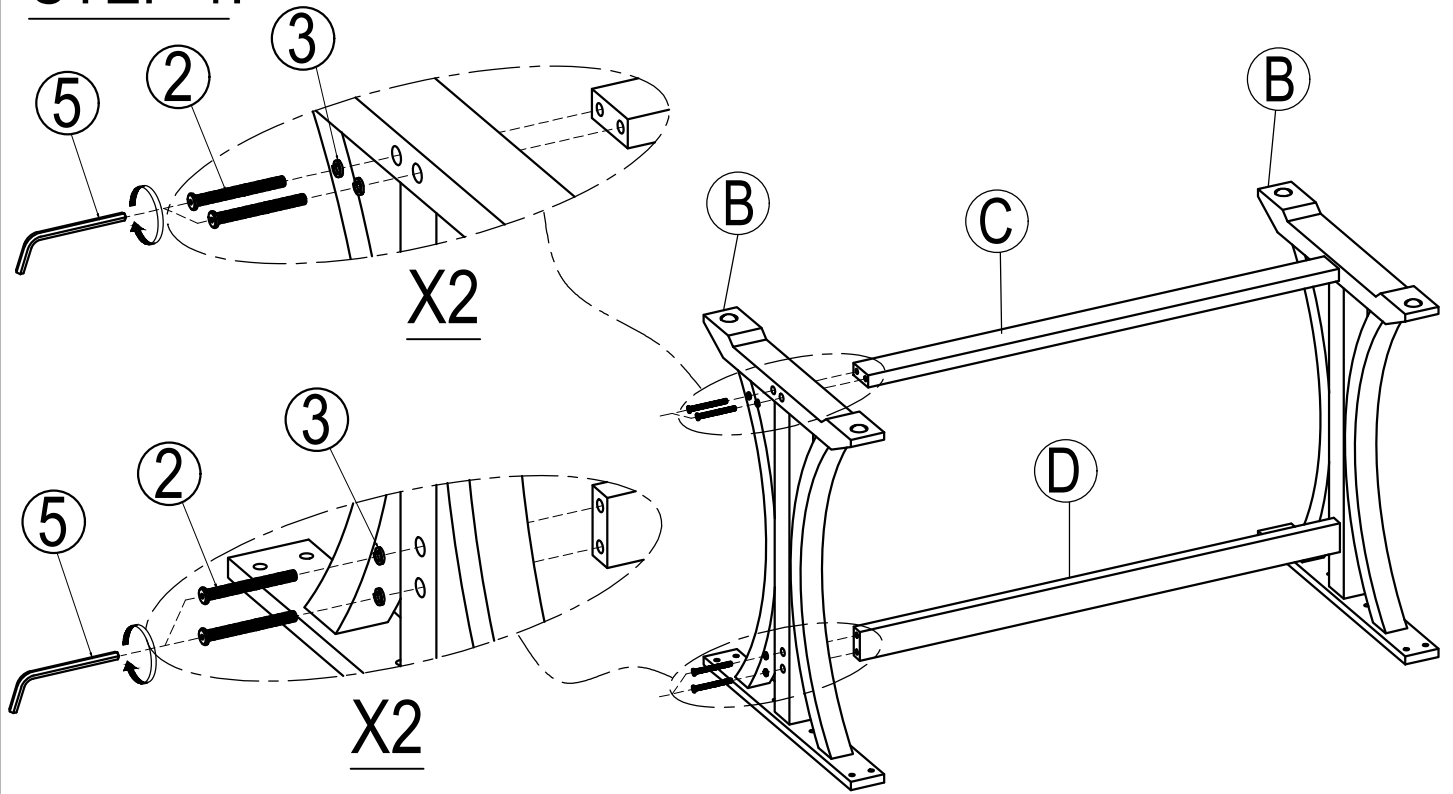

STEP 2:

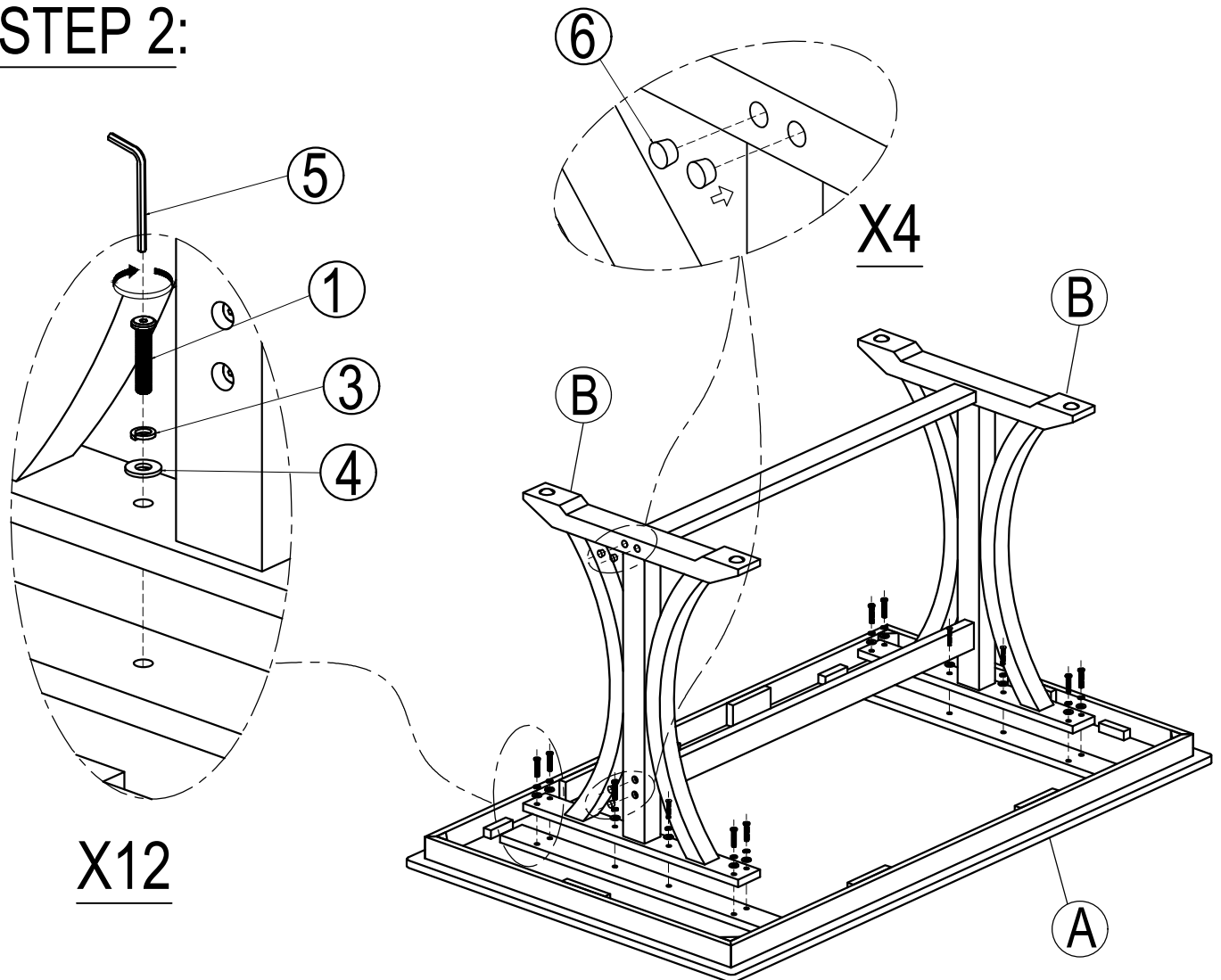

ASSEMBLY INSTRUCTIONS

ITEM NO.WF312054

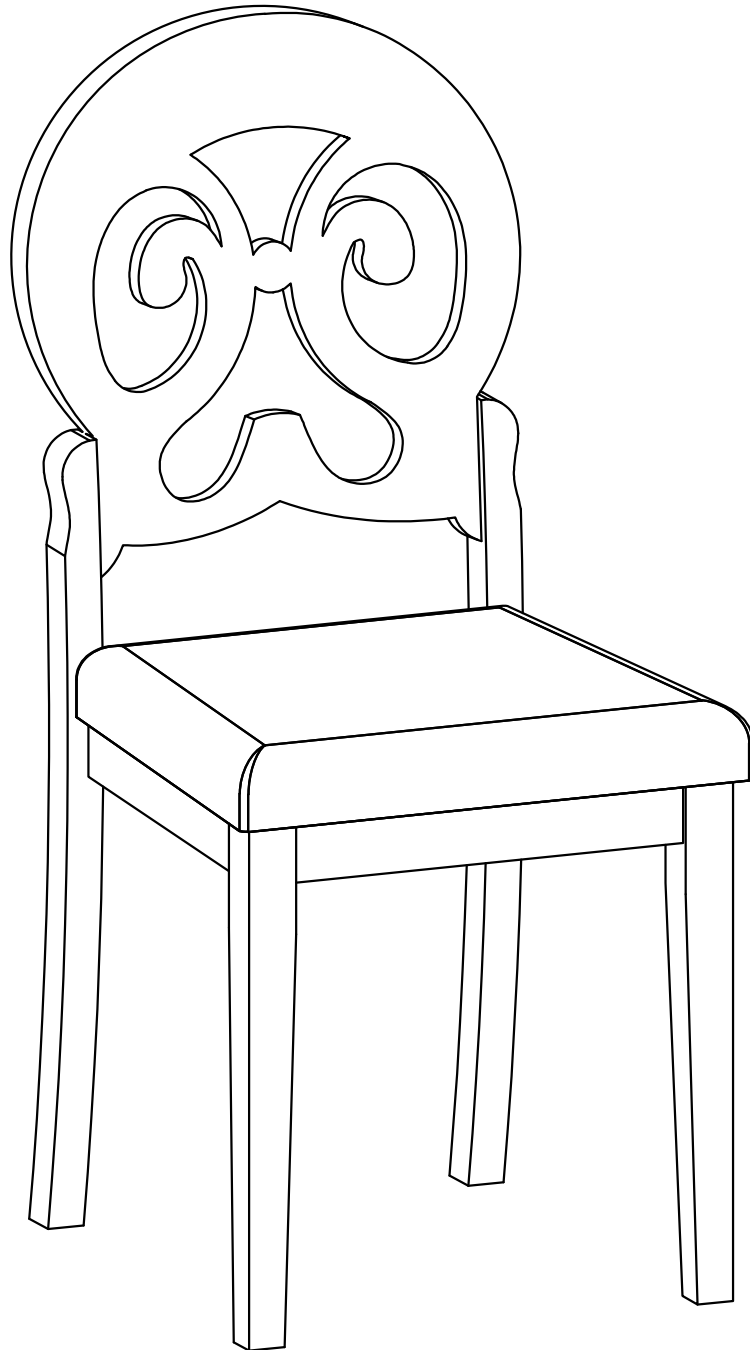



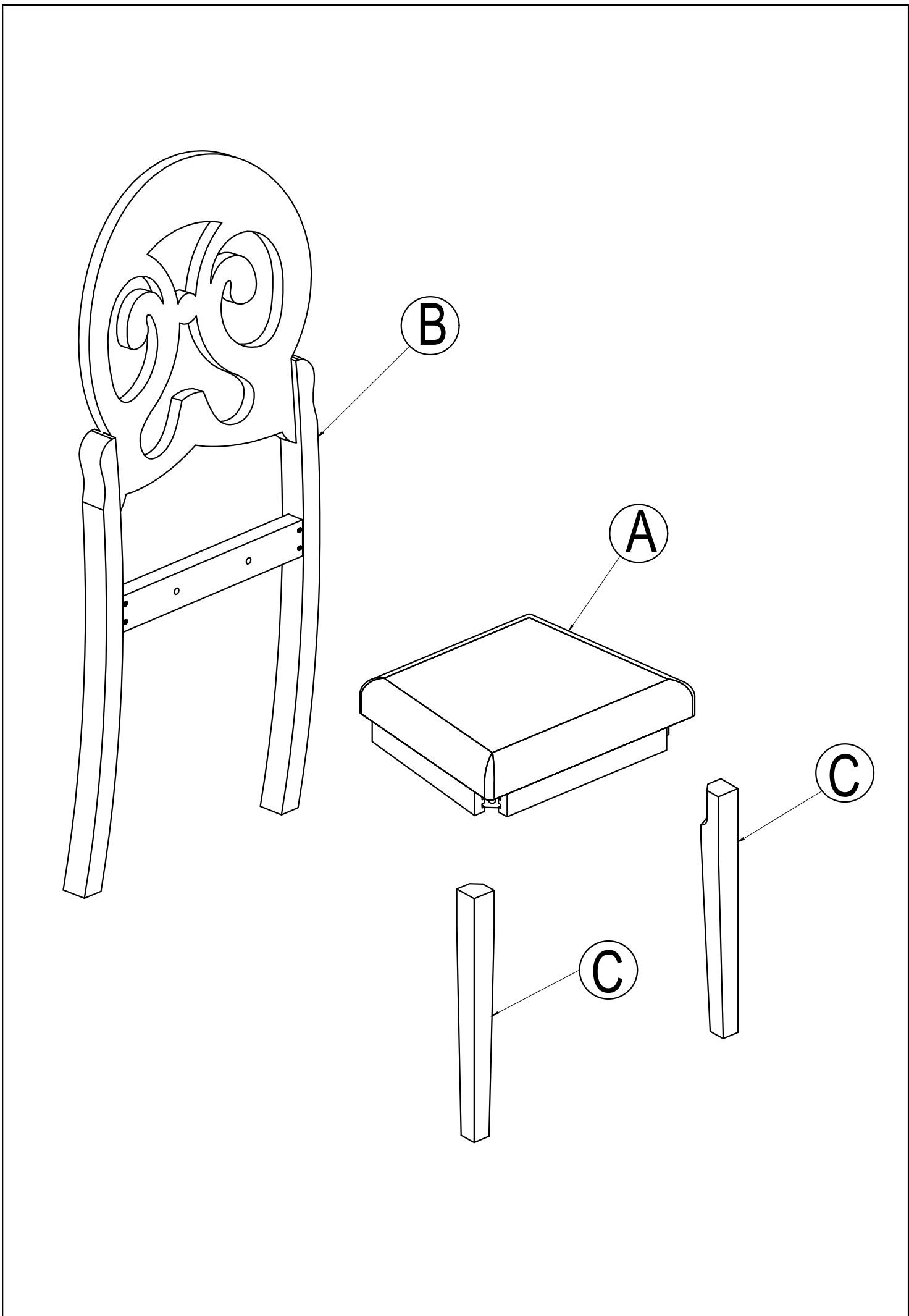

IMPORTANT NOTE :

- ① PLACE ALL PARTS ON A CLEAN AND SMOOTH SURFACE SUCH AS A RUG OR CARPET TO AVOID THE PARTS FROM BEING SCRATCHED.
- ② BEFORE YOU BEGIN,KINDLY FOLLOW THE ASSEMBLY INSTRUCTIONS STEP BY STEP.
- ③ DO NOT TIGHTEN ALL SCREWS AND BOLTS UNTIL THE CHAIR IS FULLY SET-UP.

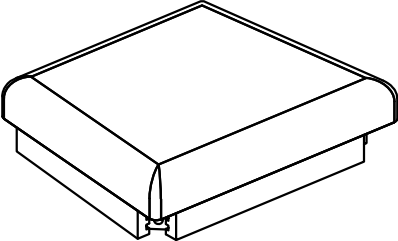
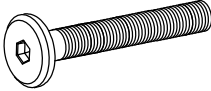
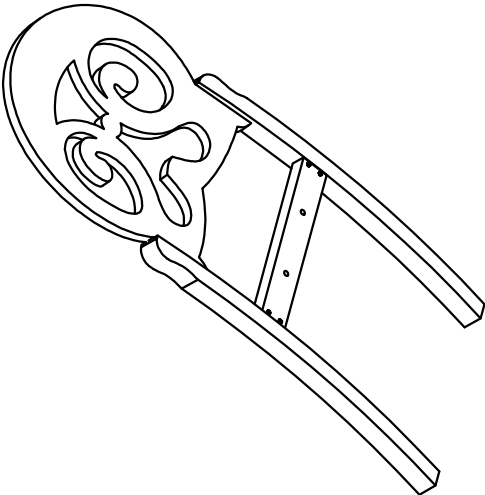
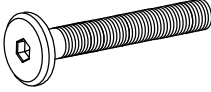
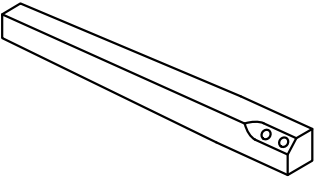
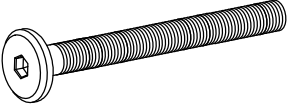

Part List

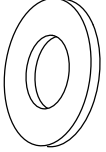
Hardware List

<p>A</p> 	<p>1</p>  <p>Ø 1/4" x 40 mm</p>
<p>CUSHION SEAT (4 pcs)</p>	<p>BOLT (8 pcs)</p>
<p>B</p> 	<p>2</p>  <p>Ø 1/4" x 55 mm</p>
<p>CHAIR BACK (4 pcs)</p>	<p>BOLT (16 pcs)</p>
<p>C</p> 	<p>3</p>  <p>Ø 1/4" x 75 mm</p>
<p>FRONT LEGS (8 pcs)</p>	<p>BOLT (16 pcs)</p>
	<p>4</p>  <p>Ø5/16" x 13 mm</p>
	<p>FLAT WASHER (40 pcs)</p>
	<p>5</p>  <p>Ø5/16" x 19 mm</p>
	<p>LOCK WASHER (40 pcs)</p>
	<p>6</p>  <p>4 mm</p>
	<p>ALLEN KEY (1 pc)</p>

STEP 1:

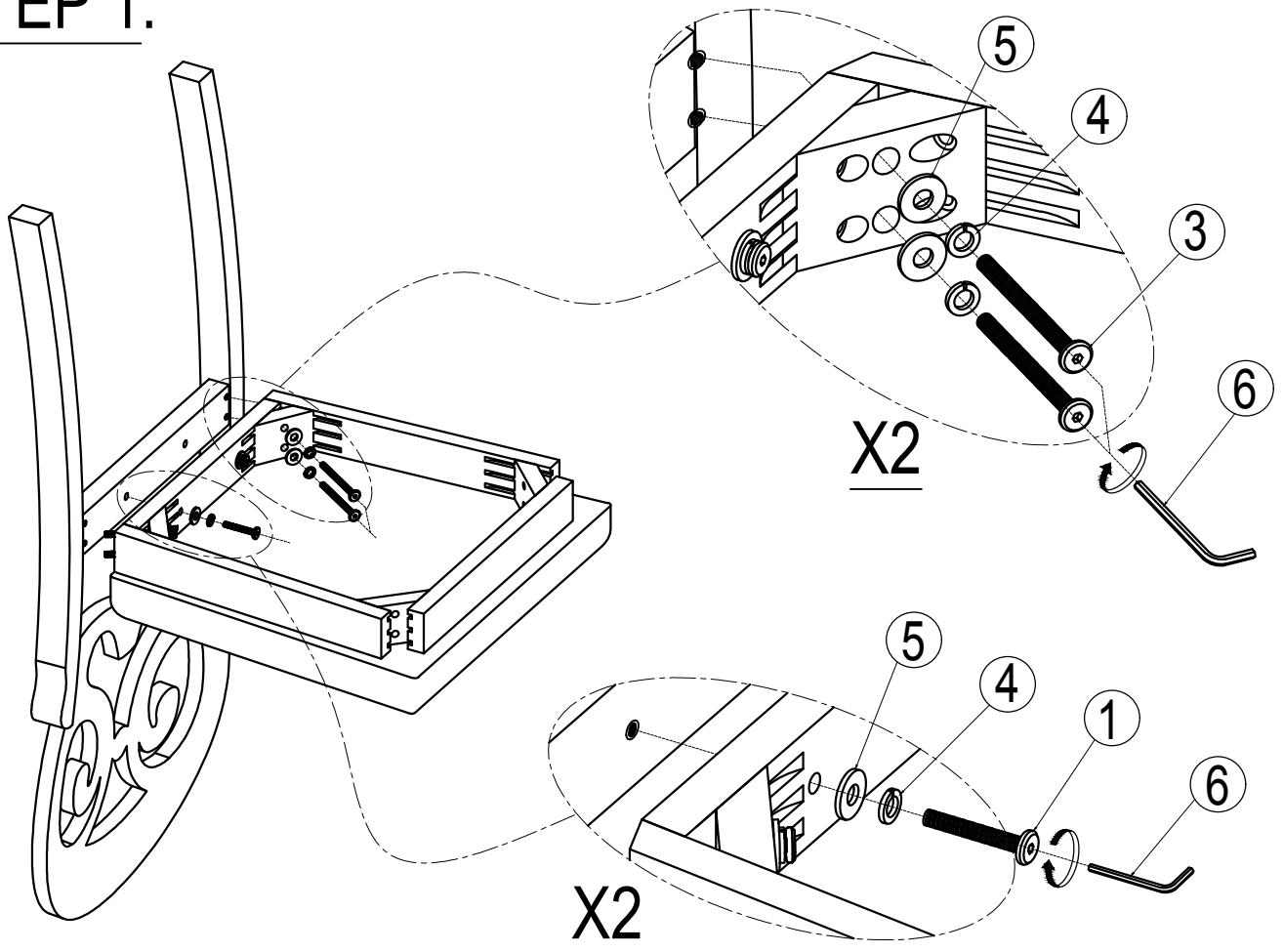

STEP 2:

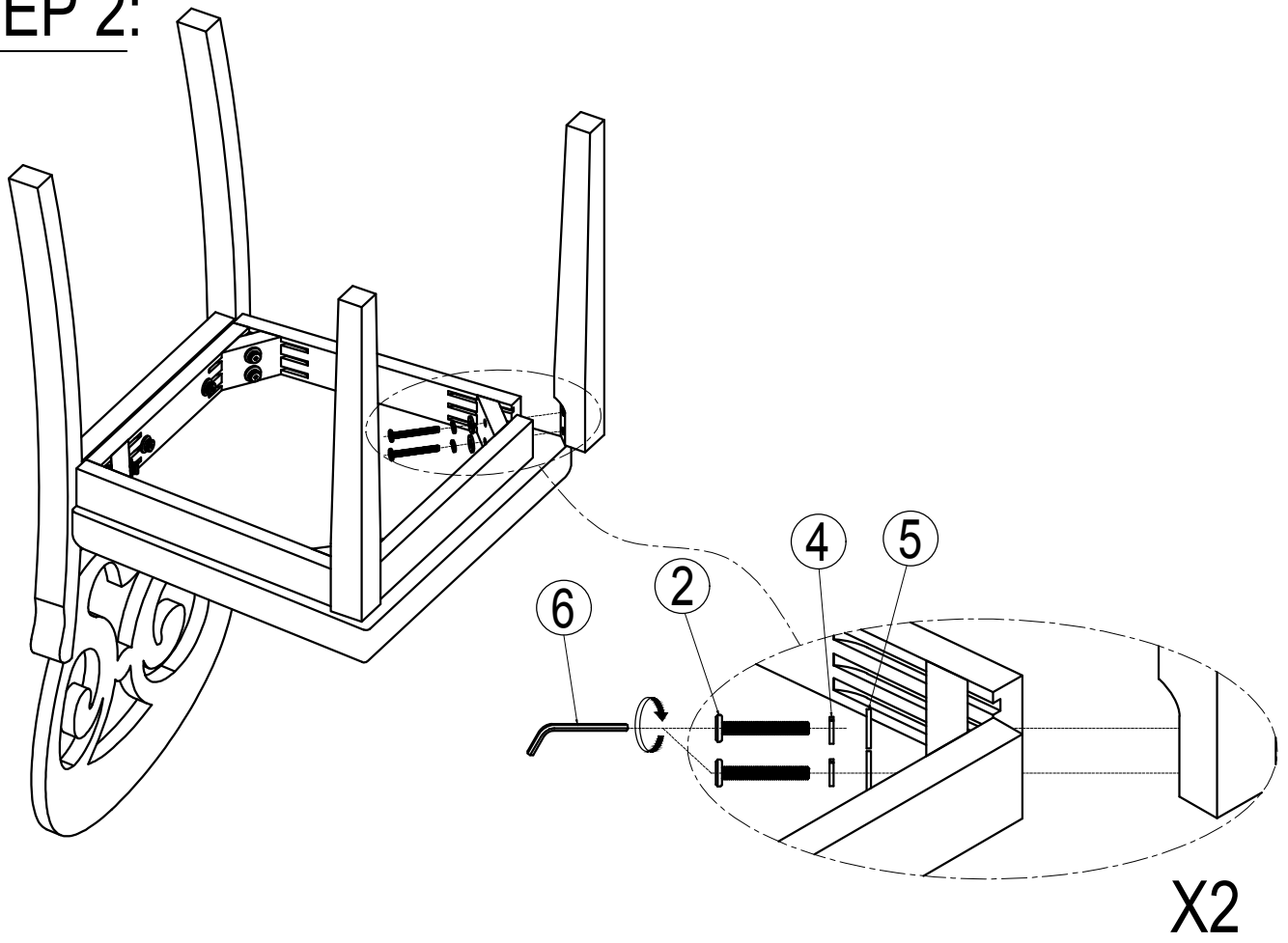

ASSEMBLY INSTRUCTIONS

ITEM NO.WF312054

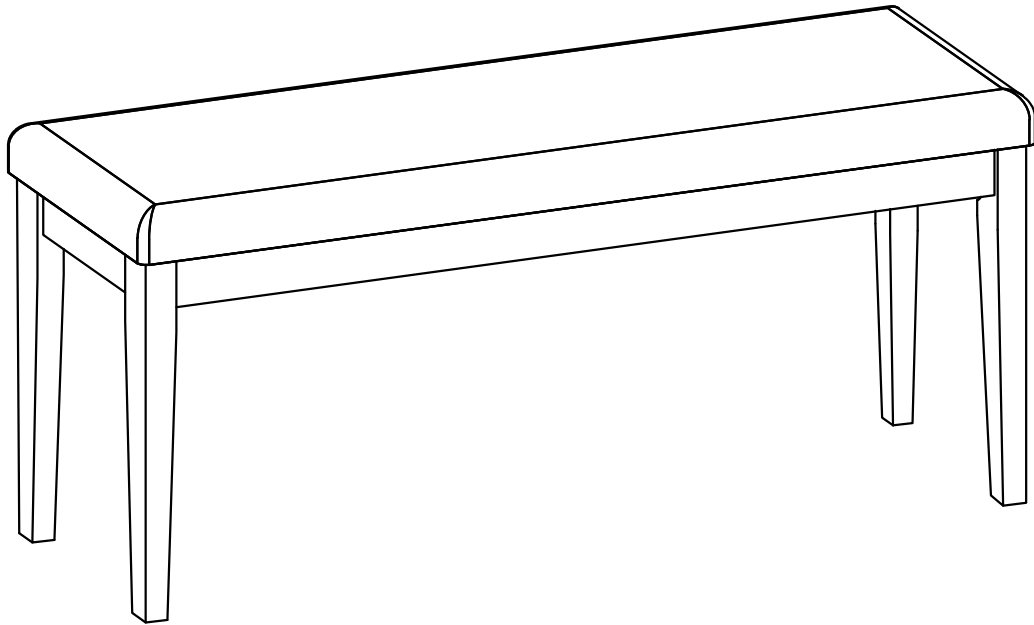





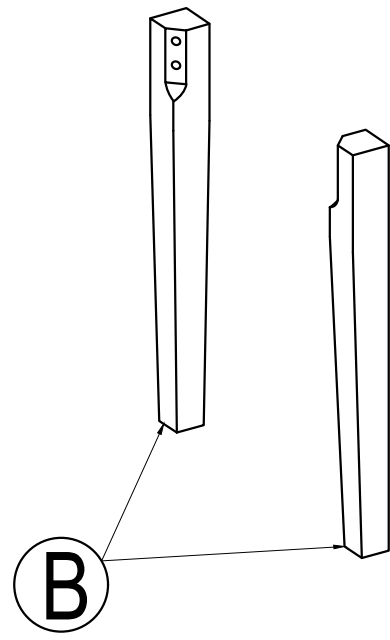
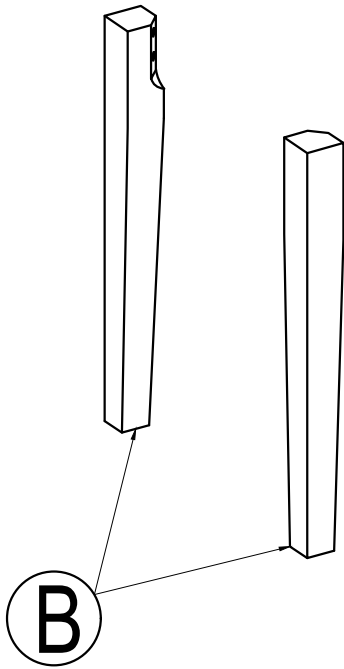
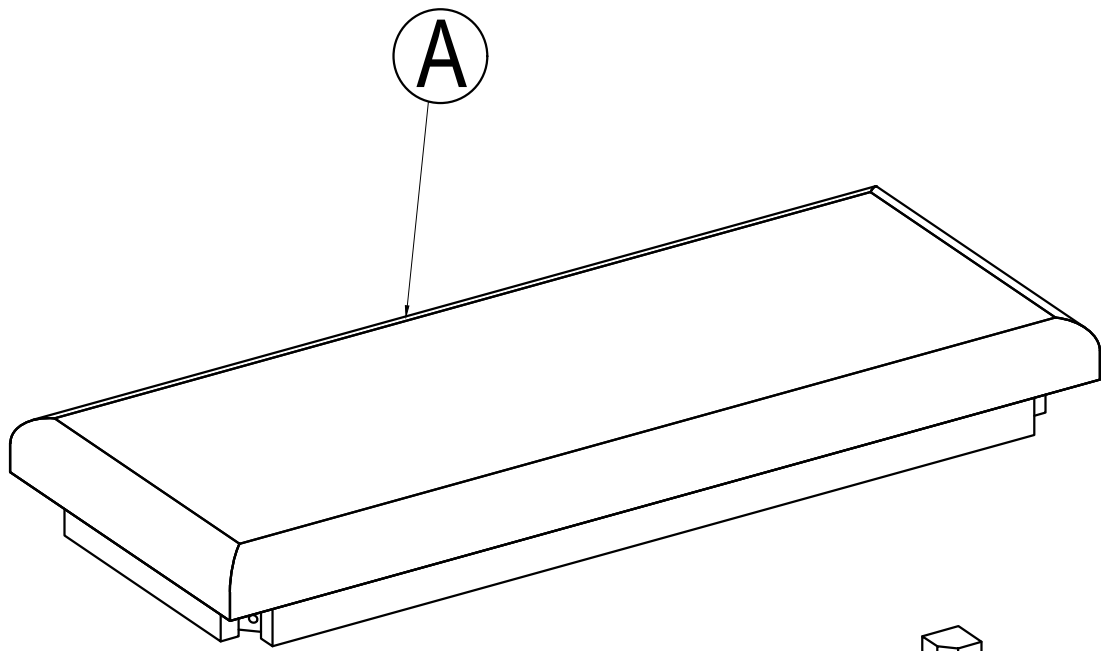

IMPORTANT NOTE :

- ① PLACE ALL PARTS ON A CLEAN AND SMOOTH SURFACE SUCH AS A RUG OR CARPET TO AVOID THE PARTS FROM BEING SCRATCHED.
- ② BEFORE YOU BEGIN,KINDLY FOLLOW THE ASSEMBLY INSTRUCTIONS STEP BY STEP.
- ③ DO NOT TIGHTEN ALL SCREWS AND BOLTS UNTIL THE BENCH IS FULLY SET-UP.

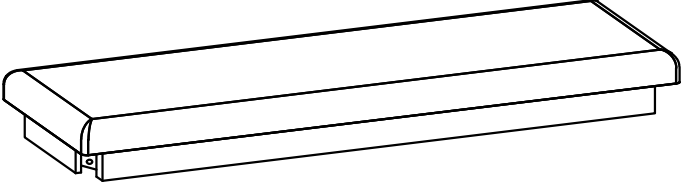

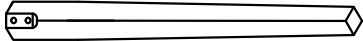
Part List

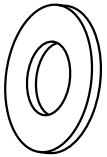
Hardware List

<p>Ⓐ</p> 	<p>①</p>  <p>Ø 1/4" x 50mm</p>
<p>CUSHION SEAT (1pcs)</p>	<p>BOLT (8pcs)</p>
<p>Ⓑ</p> 	<p>②</p>  <p>Ø5/16" x 13mm</p>
<p>LEG (4pcs)</p>	<p>FLAT WASHER (8pcs)</p>
	<p>③</p>  <p>Ø5/16" x 19mm</p>
	<p>LOCK WASHER (8pcs)</p>
	<p>④</p>  <p>4mm</p> <p>ALLEN KEY (1pc)</p>

STEP 1:

