

# ASSEMBLY INSTRUCTIONS

## DINING TABLE



**WF310411**

### **IMPORTANT NOTE:**

- PLACE ALL PARTS ON A CLEAN AND SMOOTH SURFACE SUCH AS A RUG OR CARPET TO AVOID THE PARTS FROM BEING SCRATCHED.
- BEFORE YOU BEGIN, KINDLY FOLLOW THE ASSEMBLY INSTRUCTIONS STEP BY STEP.
- DO NOT TIGHTEN ALL SCREWS AND BOLTS UNTIL THE TABLE IS FULLY SET-UP.

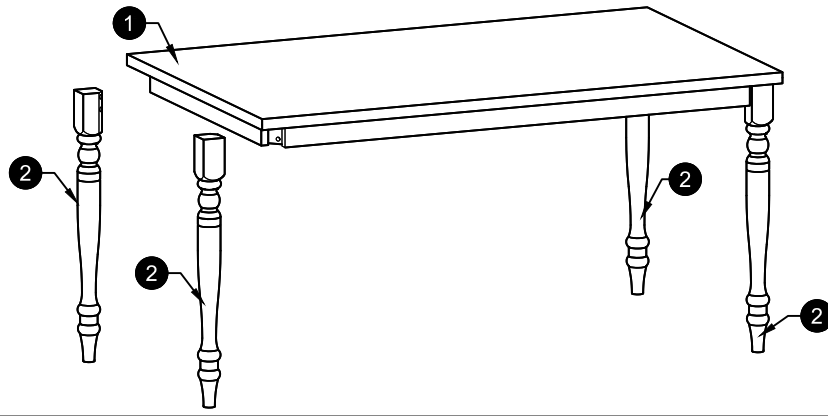

**CARTON CONTENT:**

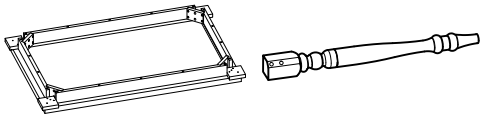

WF310411 :





1 x 1

2 x 4

**TABLE PART LISTS**

NO.	DESCRIPTION	SKETCH	QTY
1	TABLE TOP		1 PC
2	TABLE LEG		4 PCS

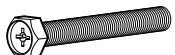
**TABLE HARDWARE LISTS**

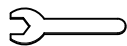
NO.	DESCRIPTION	SKETCH	QTY
A	HEX COMB 5/16 x 2 1/2"		8 PCS
B	SPRING WASHER 5/16"		8 PCS
C	FLAT WASHER 5/16"		8 PCS
D	SPANNER 1.28		1 PC

**STEP 1**

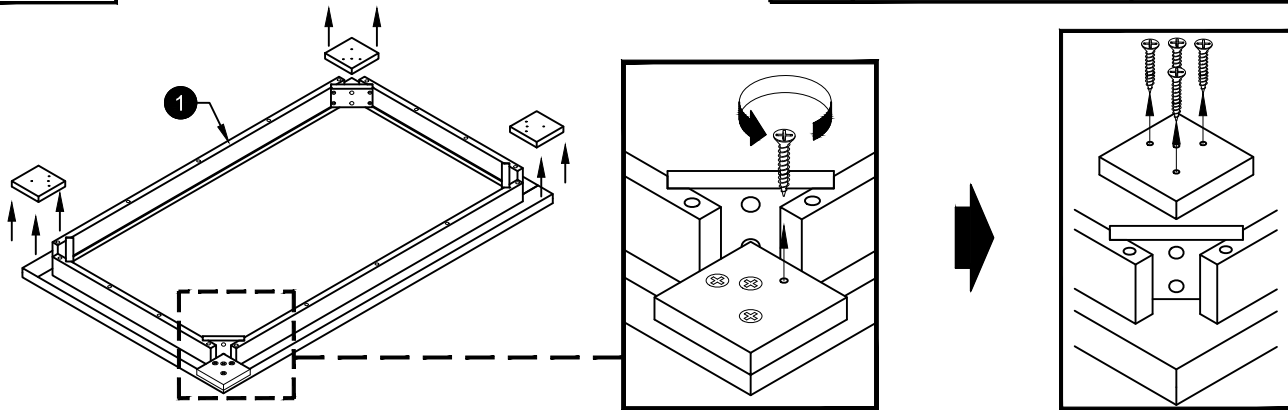

**STEP 2**

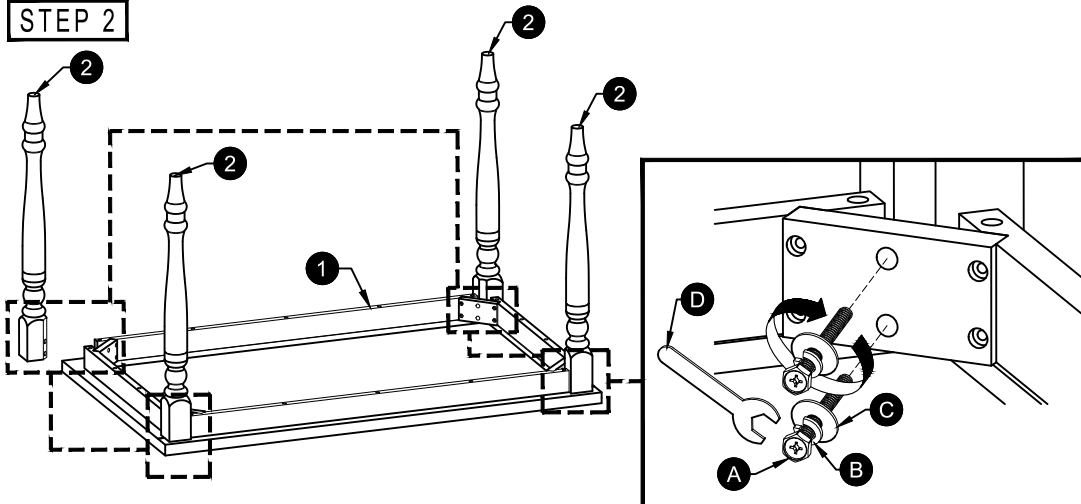

**ASSEMBLY COMPLETE !**



# ASSEMBLY INSTRUCTIONS

## DINING CHAIR

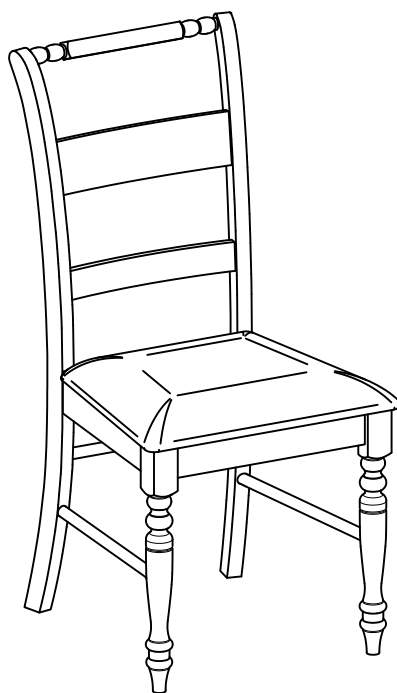

**WF310412**

### **IMPORTANT NOTE:**

- PLACE ALL PARTS ON A CLEAN AND SMOOTH SURFACE SUCH AS A RUG OR CARPET TO AVOID THE PARTS FROM BEING SCRATCHED.
- BEFORE YOU BEGIN, KINDLY FOLLOW THE ASSEMBLY INSTRUCTIONS STEP BY STEP.
- DO NOT TIGHTEN ALL SCREWS AND BOLTS UNTIL THE CHAIR IS FULLY SET-UP.

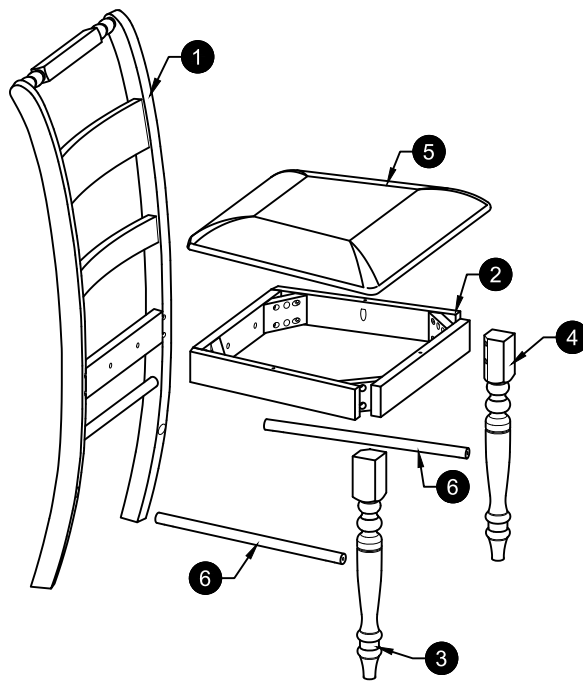

**CARTON CONTENT:**

WF310412 :

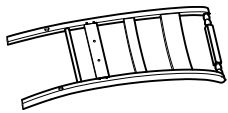

1 x 4

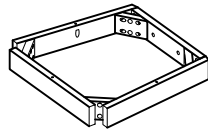

2 x 4



3 x 4

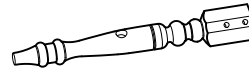

4 x 4

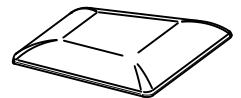

5 x 4



6 x 8

**CHAIR PART LISTS**

NO.	DESCRIPTION	SKETCH	QTY
1	BACK LEG		4 PCS
2	BOX SEAT		4 PCS
3	FRONT LEG ( L )		4 PCS
4	FRONT LEG ( R )		4 PCS
5	SEAT		4 PCS
6	STRETCHER		8 PCS

**CHAIR HARDWARE LISTS**

NO.	DESCRIPTION	SKETCH	QTY
A	JCBC BOLT M6 x 35mm		8 PCS
B	JCBC BOLT M6 x 60mm		16 PCS
C	JCBC BOLT M6 x 80mm		16 PCS
D	SPRING WASHER 1/4"		40 PCS
E	FLAT WASHER 1/4"		40 PCS
F	ALLEN KEY M4		1 PC
G	C/B SCREW M4 x 30mm		12 PCS
H	C/B SCREW M4 x 45mm		16 PCS

STEP 1

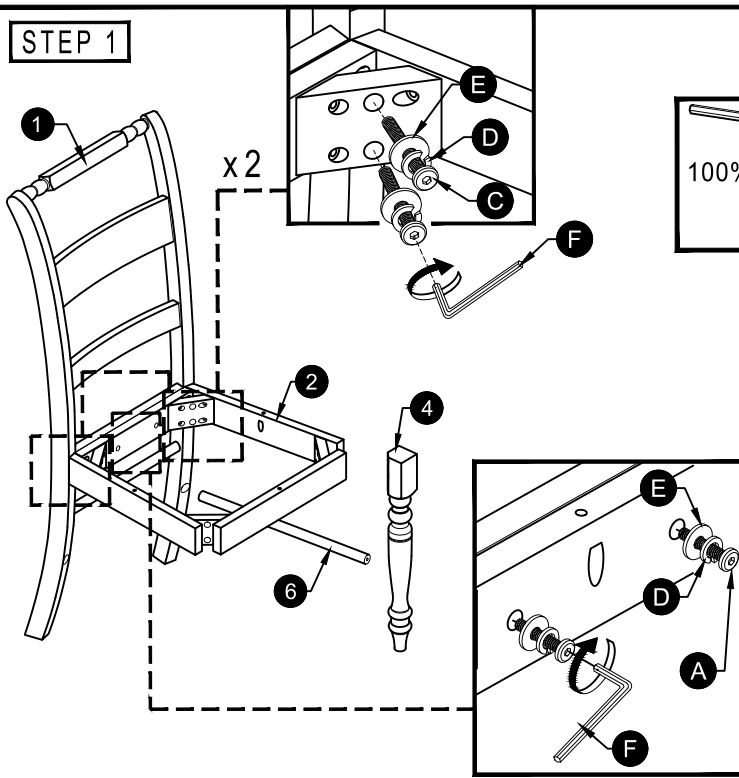

STEP 2

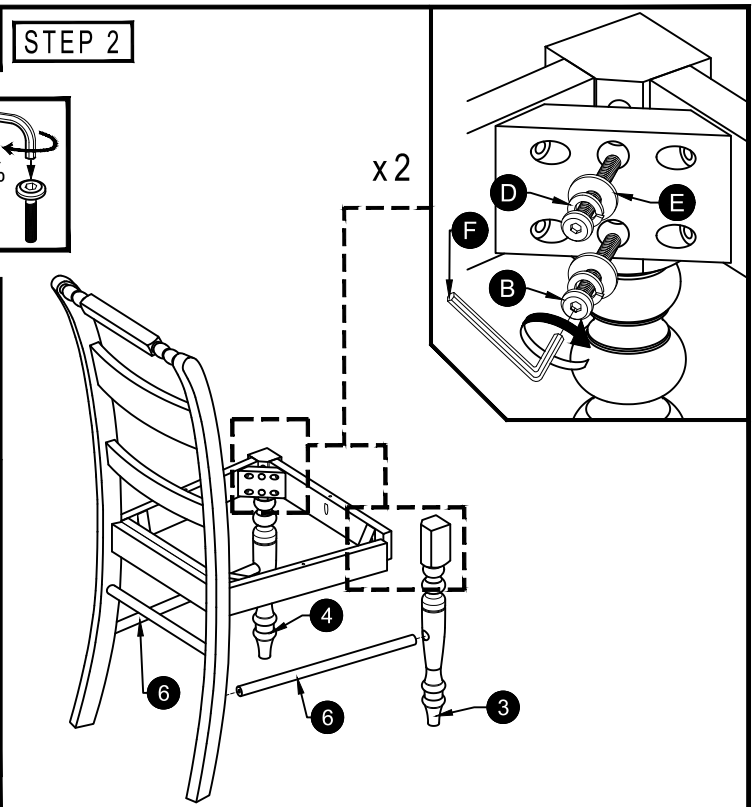

STEP 3

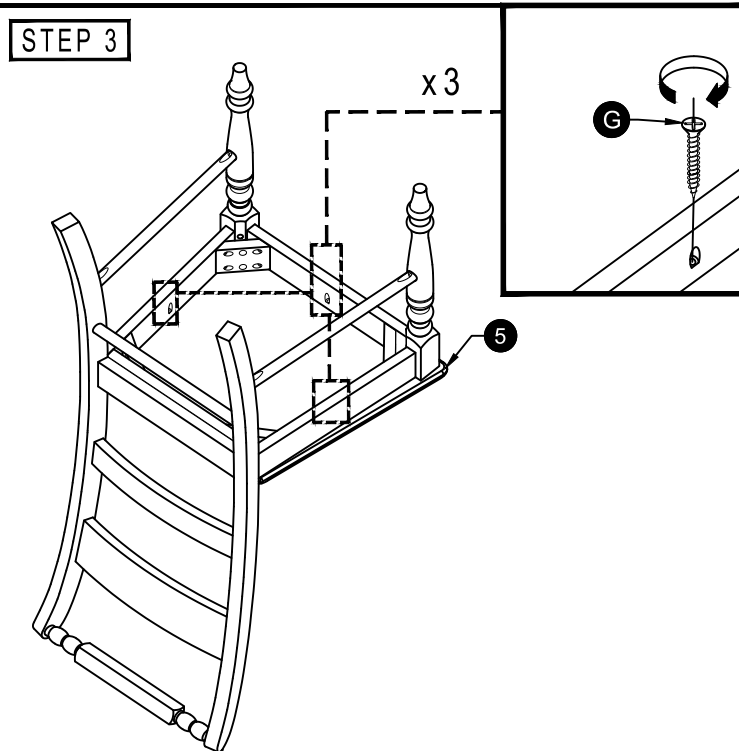

STEP 4

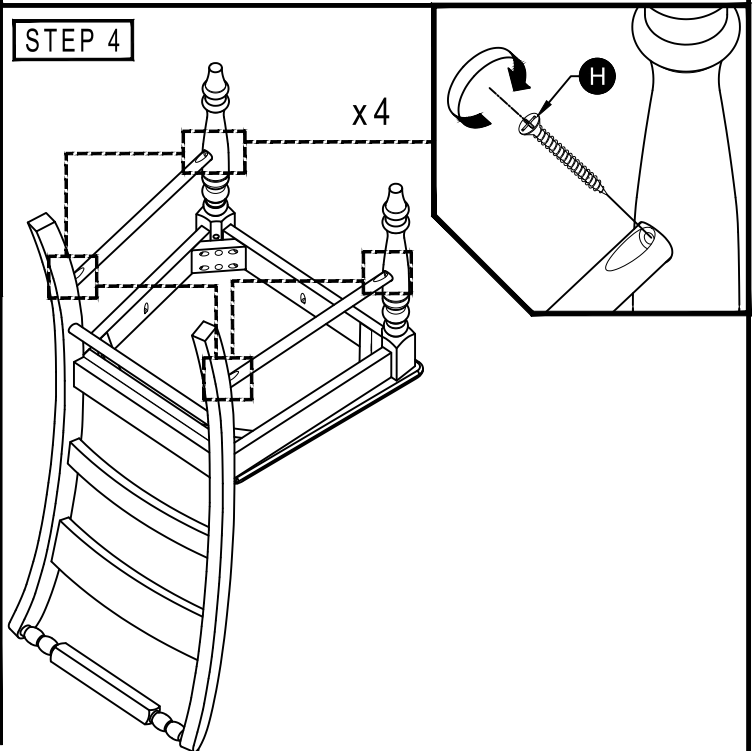

ASSEMBLY COMPLETE !

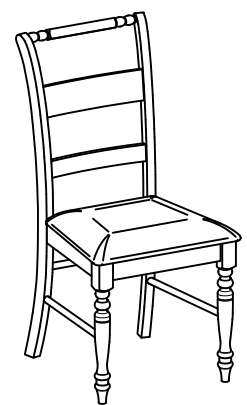

# ASSEMBLY INSTRUCTIONS

## DINING BENCH

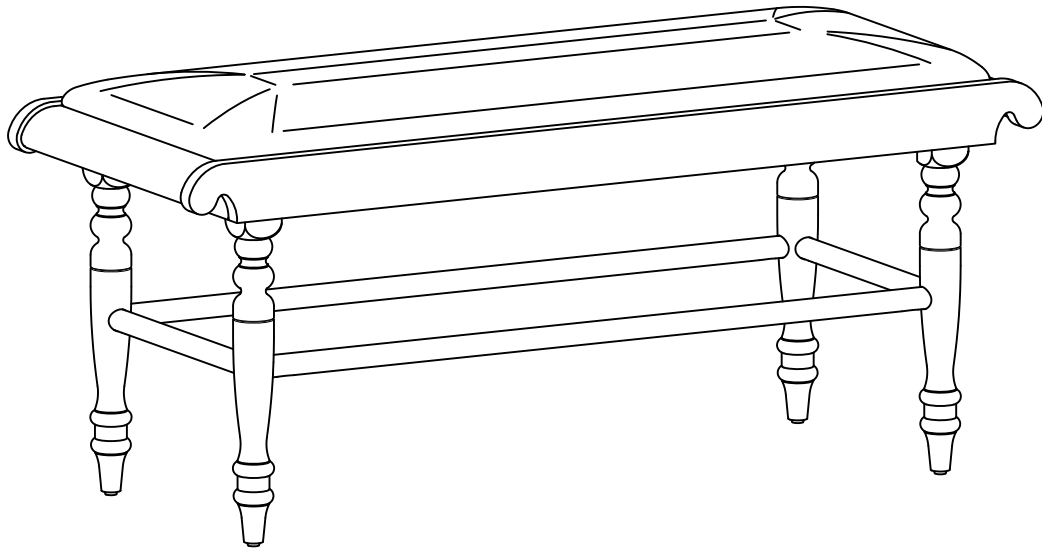

**WF310412**

### **IMPORTANT NOTE:**

- PLACE ALL PARTS ON A CLEAN AND SMOOTH SURFACE SUCH AS A RUG OR CARPET TO AVOID THE PARTS FROM BEING SCRATCHED.
- BEFORE YOU BEGIN, KINDLY FOLLOW THE ASSEMBLY INSTRUCTIONS STEP BY STEP.
- DO NOT TIGHTEN ALL SCREWS AND BOLTS UNTIL THE BENCH IS FULLY SET-UP.

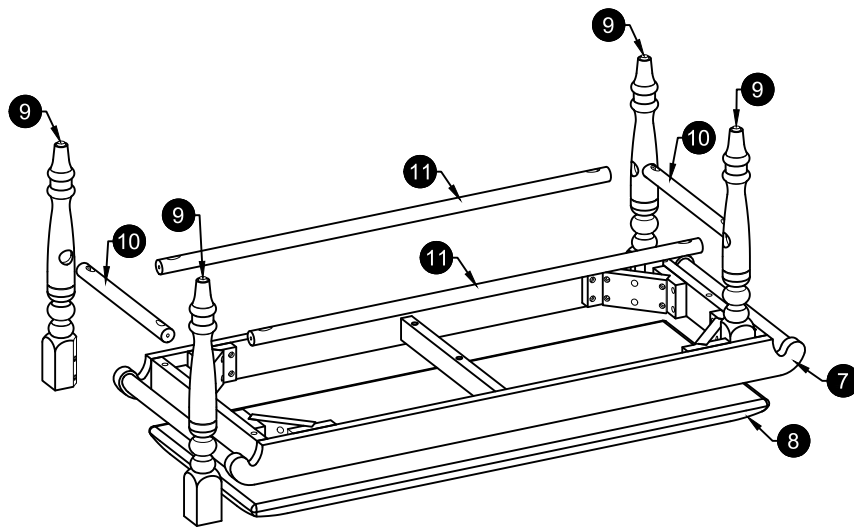

**CARTON CONTENT:**

WF310412 :

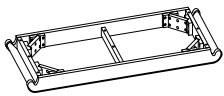

7 x 1



8 x 1



9 x 4

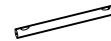

10 x 2



11 x 2

**BENCH PART LISTS**

NO.	DESCRIPTION	SKETCH	QTY
7	BOX SEAT		1 PC
8	SEAT		1 PC
9	LEG		4 PCS
10	STRETCHER (S)		2 PCS
11	STRETCHER (L)		2 PCS

**BENCH HARDWARE LISTS**

NO.	DESCRIPTION	SKETCH	QTY
I	C/B SCREW M4 x 45mm		17 PCS
J	JCBC BOLT M6 x 60mm		8 PCS
K	SPRING WASHER 1/4"		8 PCS
L	FLAT WASHER 1/4"		8 PCS
M	ALLEN KEY M4		1 PC

**STEP 1**

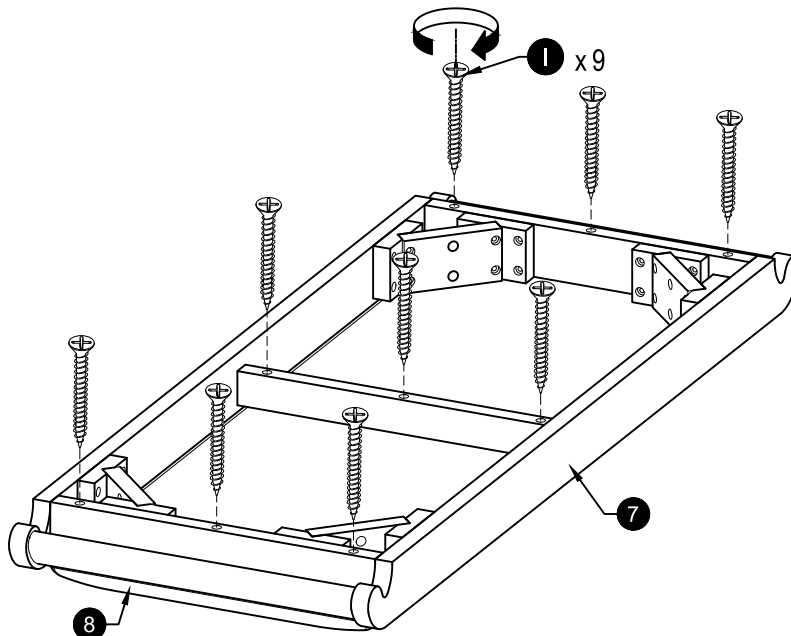

STEP 2

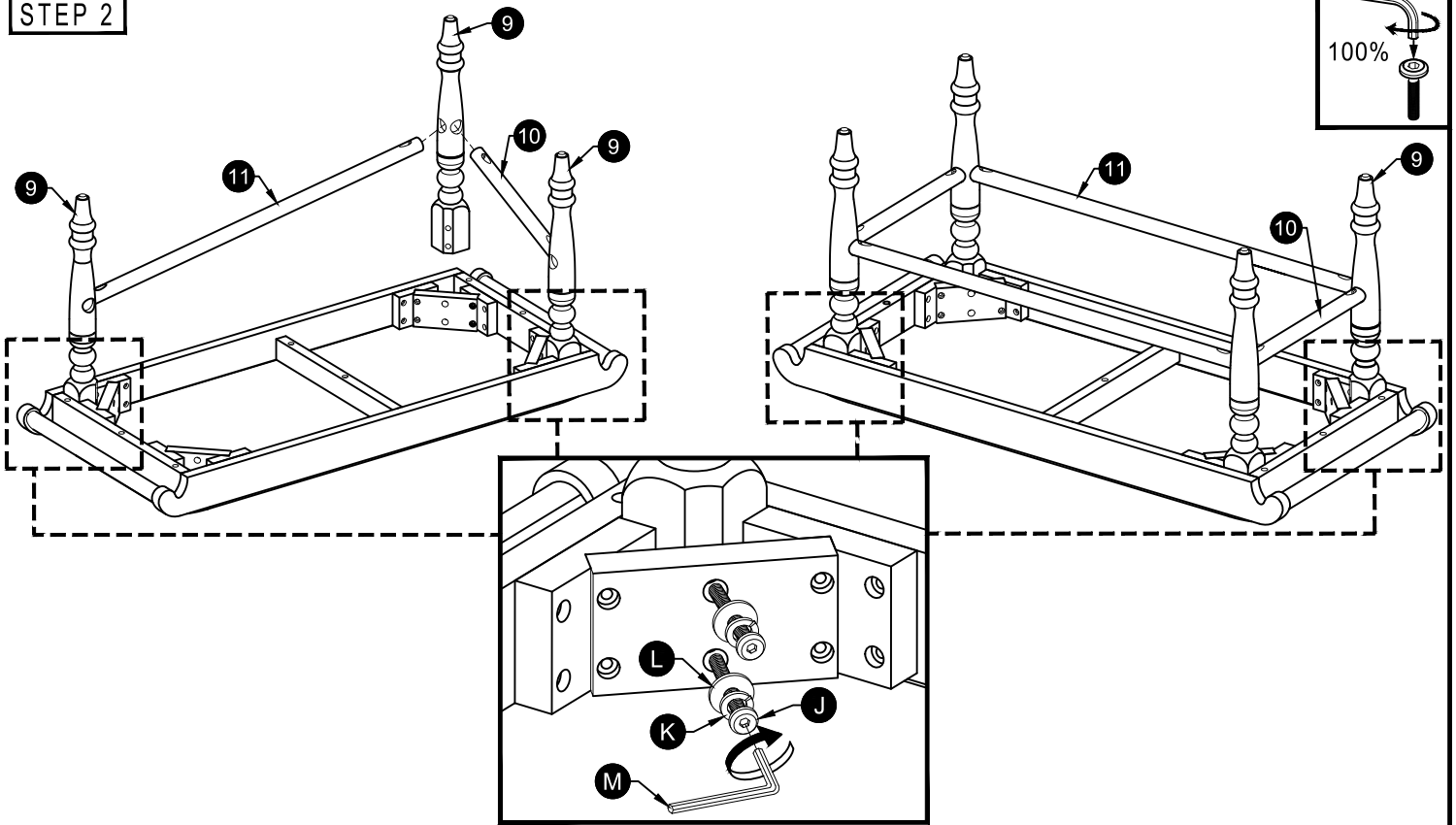

STEP 3

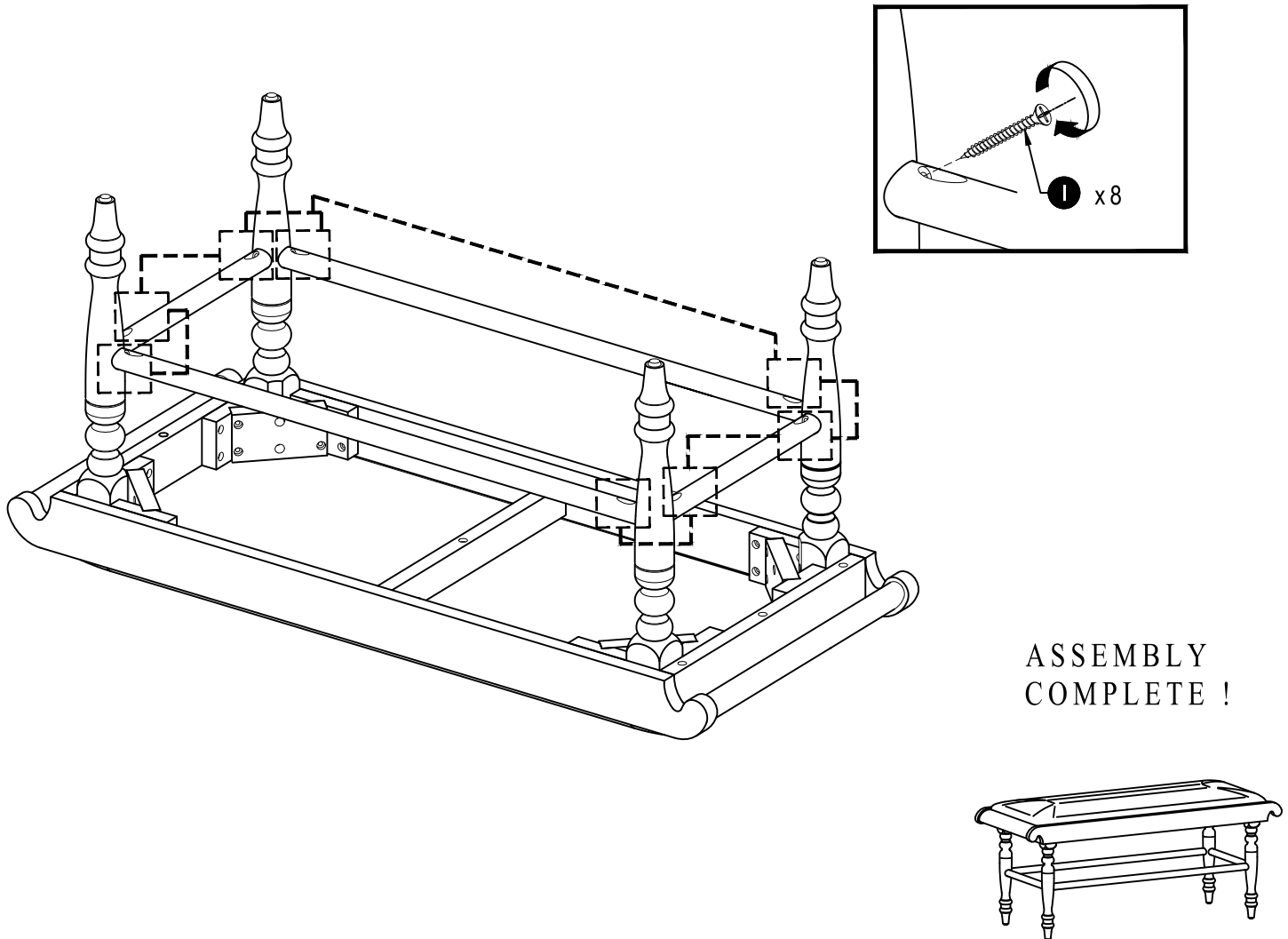

ASSEMBLY COMPLETE !

