

ASSEMBLY INSTRUCTION

ITEM:WF309923/24/25 DINING TABLE SET

Important note:

1. Place all wooden parts on a clean and smooth surface such as a rug or carpet to avoid scratching the parts.
2. Kindly follow the assembly instructions step by step.
3. Do not tighten all screws and bolts until the table is fully assembled.
4. Unscrew the protective plastique supports from the metal insert of the table legs before assembly.



ASSEMBLY INSTRUCTION

ITEM:WF309923/WF309924

Important note:

1. Place all wooden parts on a clean and smooth surface such as a rug or carpet to avoid scratching the parts.
2. Kindly follow the assembly instructions step by step.
3. Do not tighten all screws and bolts until the table is fully assembled.
4. Unscrew the protective plastique supports from the metal insert of the table legs before assembly.

PARTS IDENTIFICATION

A Table Top

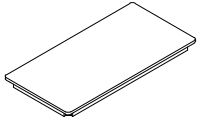

1pc

B Table Leg

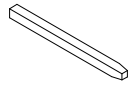

1pc

C Table Leg

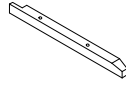

1pc

D Table Leg

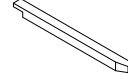

1pc

E Table Leg

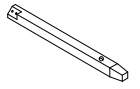

1pc

F Short stretcher

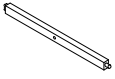

1pc

G Long stretcher

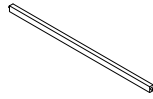

1pc

H Cabinet

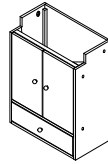

1pc

I Sheft

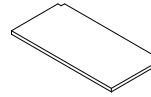

1pc

HARDWARE IDENTIFICATION

1 Long Bolt

Ø5/16"x65mm



8pcs

2 Spring Washer

Ø5/16"x13mm



8pcs

3 Flat Washer

Ø5/16"x19mm



8pcs

4 Bolt

Ø1/4"x38mm



6pcs

5 Spring Washer

Ø1/4"x11mm



6pcs

6 Flat Washer

Ø1/4"x19mm



6pcs

7 Allen Key

M4

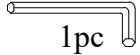

1pc

8 T Metal Bracket



1pc

9 L Metal Bracket



1pc

10 Wood screw

#8x38mm

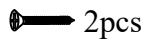

2pcs

11 Wood screw

#6x15mm



6pcs

12 Shelves



4pcs

STEP 1

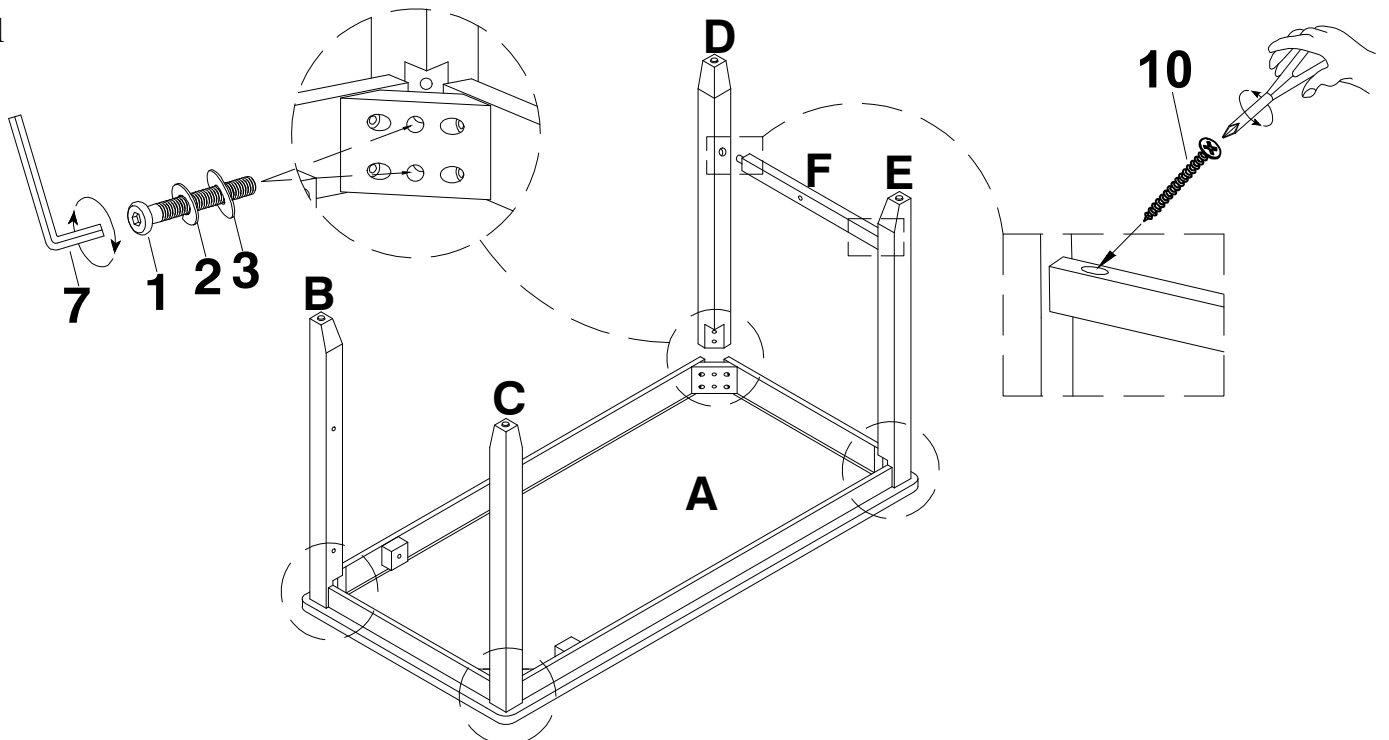

ASSEMBLY INSTRUCTION
ITEM:WF309923/WF309924

STEP 2

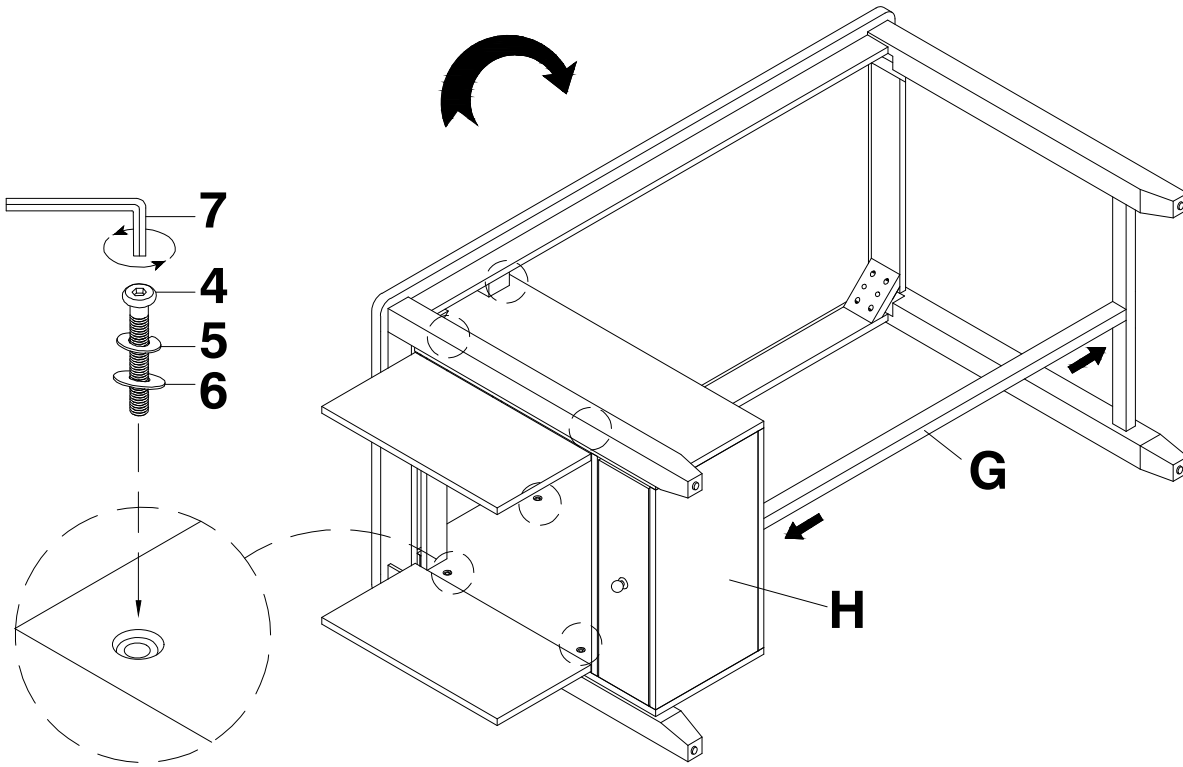

STEP 3

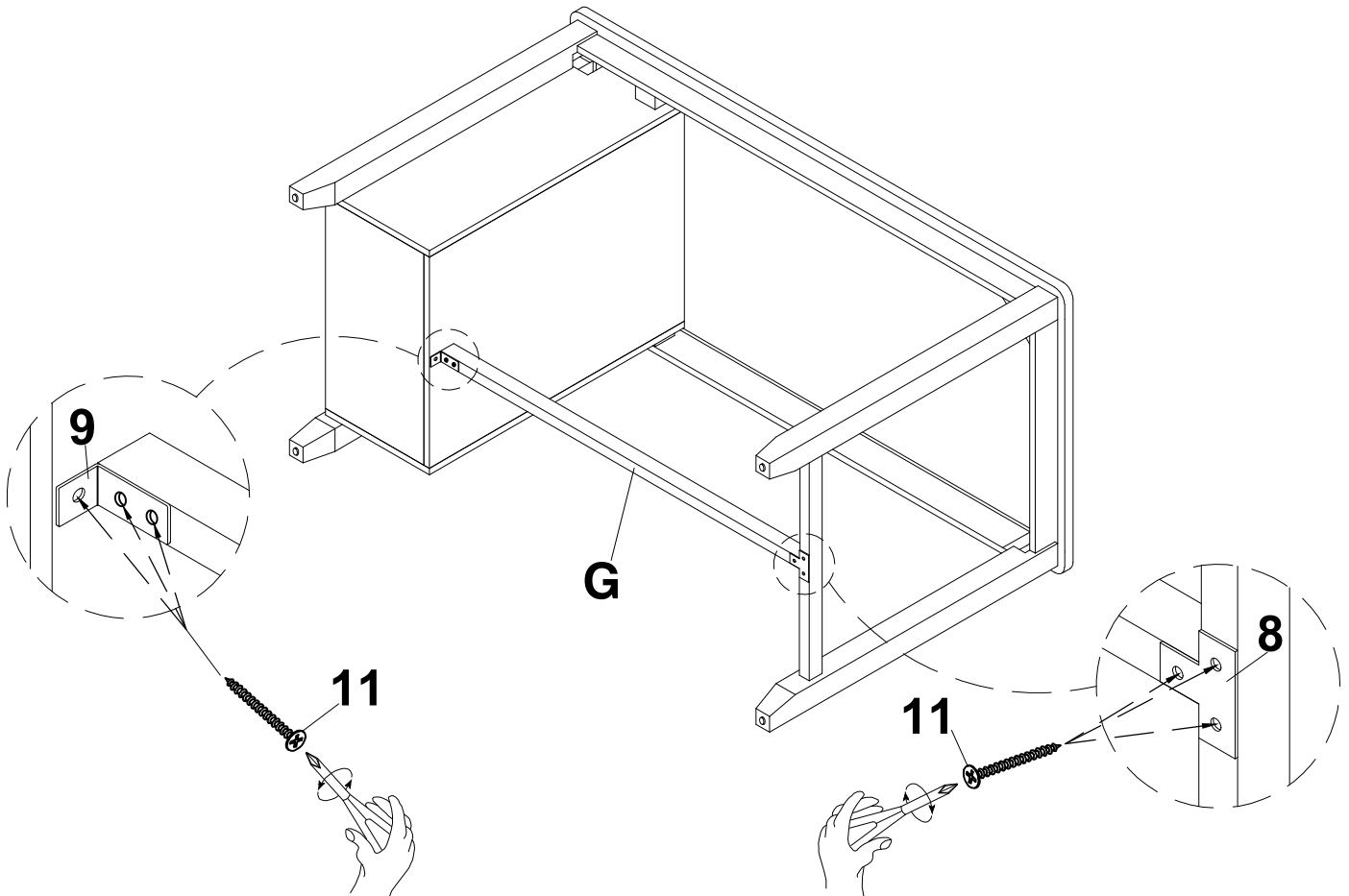

ASSEMBLY INSTRUCTION
ITEM:WF309923/WF309924

STEP 4

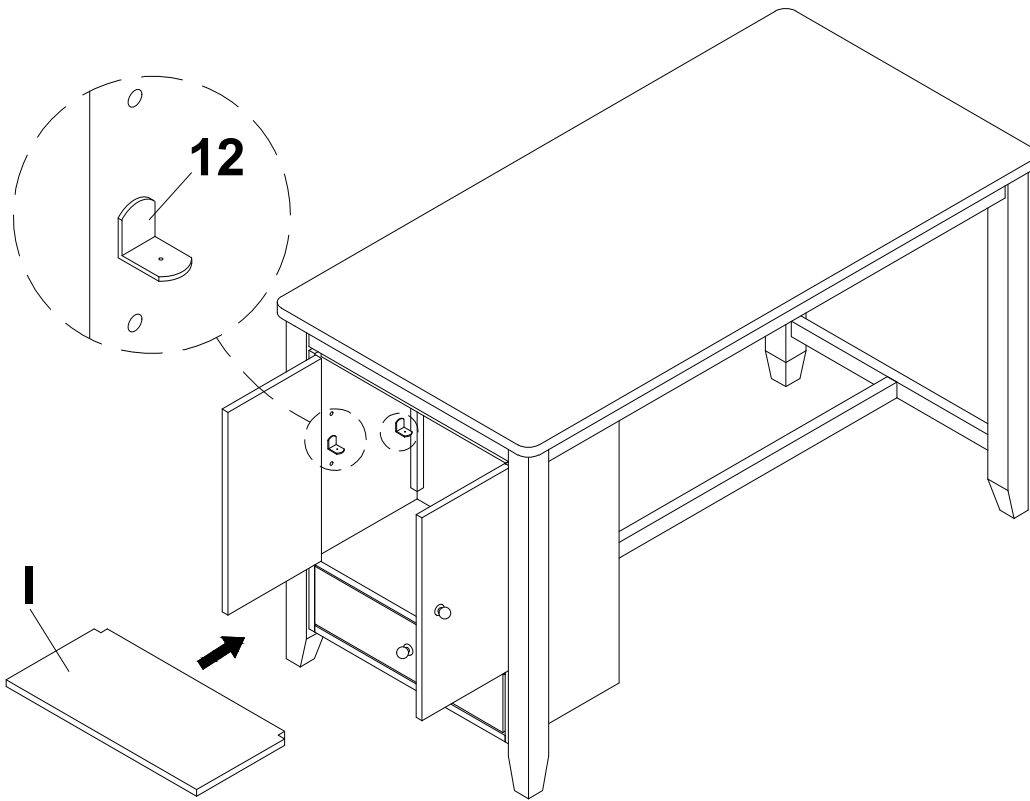

COMPLETE

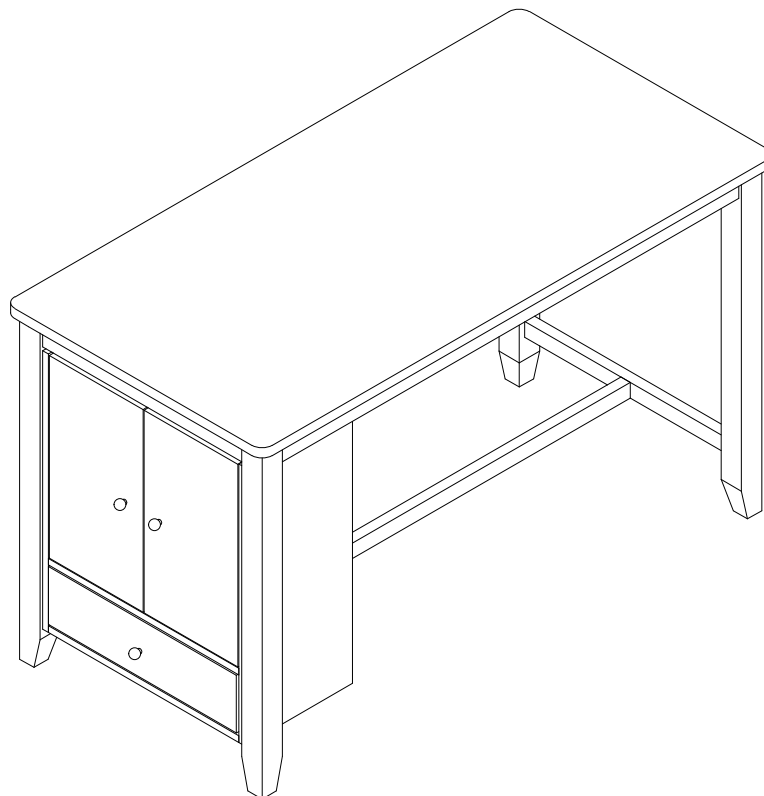

ASSEMBLY INSTRUCTION

ITEM:WF309925

Important note:

1. Place all wooden parts on a clean and smooth surface such as a rug or carpet to avoid scratching the parts.
2. Kindly follow the assembly instructions step by step.
3. Do not tighten all screws and bolts until the table is fully assembled.
4. Unscrew the protective plastique supports from the metal insert of the table legs before assembly.

PARTS IDENTIFICATION

A Chair Back

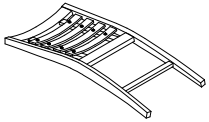

1pc

B Wooden Seat

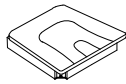

1pc

C Left Leg

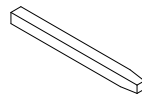

1pc

D Right Leg

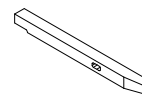

1pc

E Left Stretcher

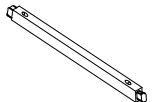

1pc

F Right Stretcher

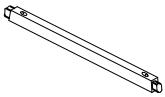

1pc

G Front Stretcher

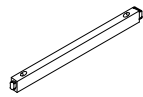

1pc

HARDWARE IDENTIFICATION

1 Bolt
Ø1/4"x38mm



2pcs

2 Bolt
Ø1/4"x60mm



4pcs

3 Long Bolt
Ø1/4"x80mm



4pcs

4 Spring Washer
Ø1/4"x11mm

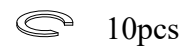

10pcs

5 Flat Washer
Ø1/4"x19mm

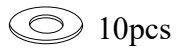

10pcs

6 Wood screw
#8x38mm

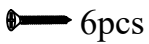

6pcs

7 Allen Key
M4

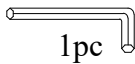

1pc

STEP 1

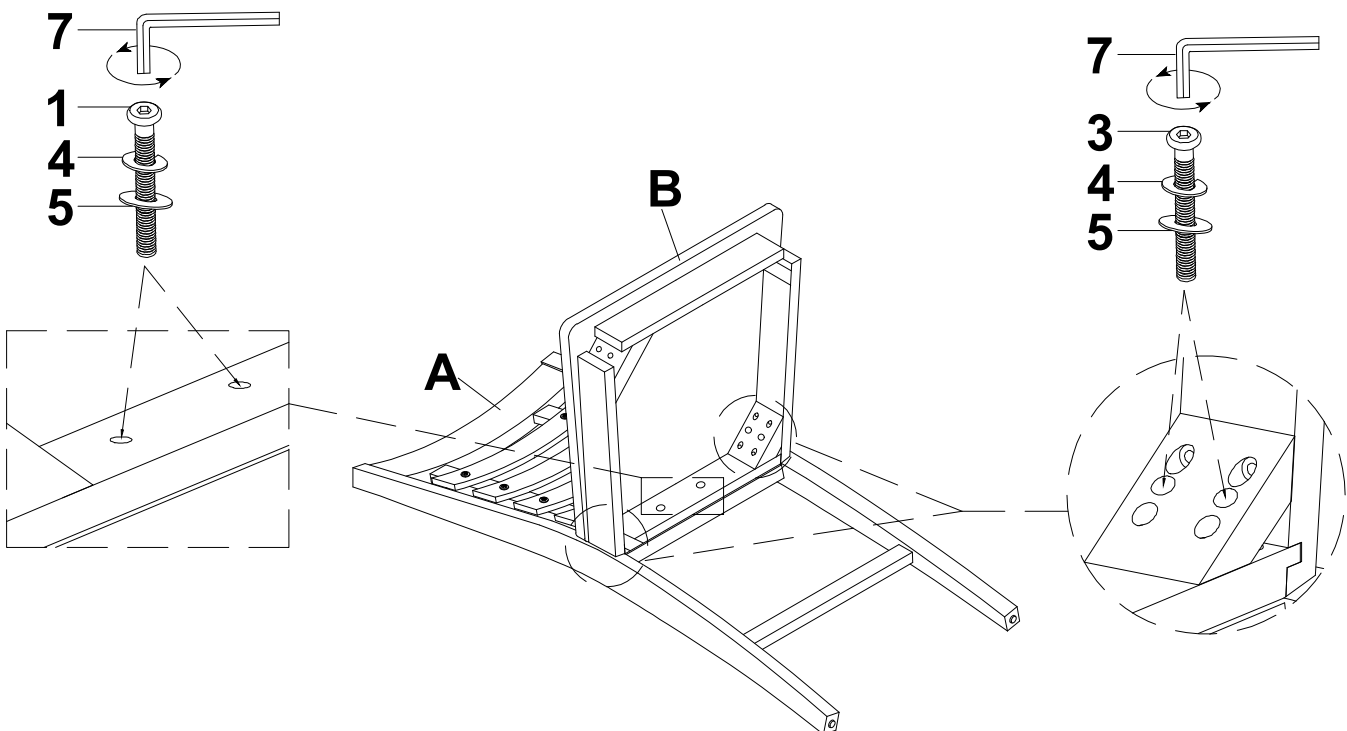

ASSEMBLY INSTRUCTION
ITEM:WF309925

STEP 2

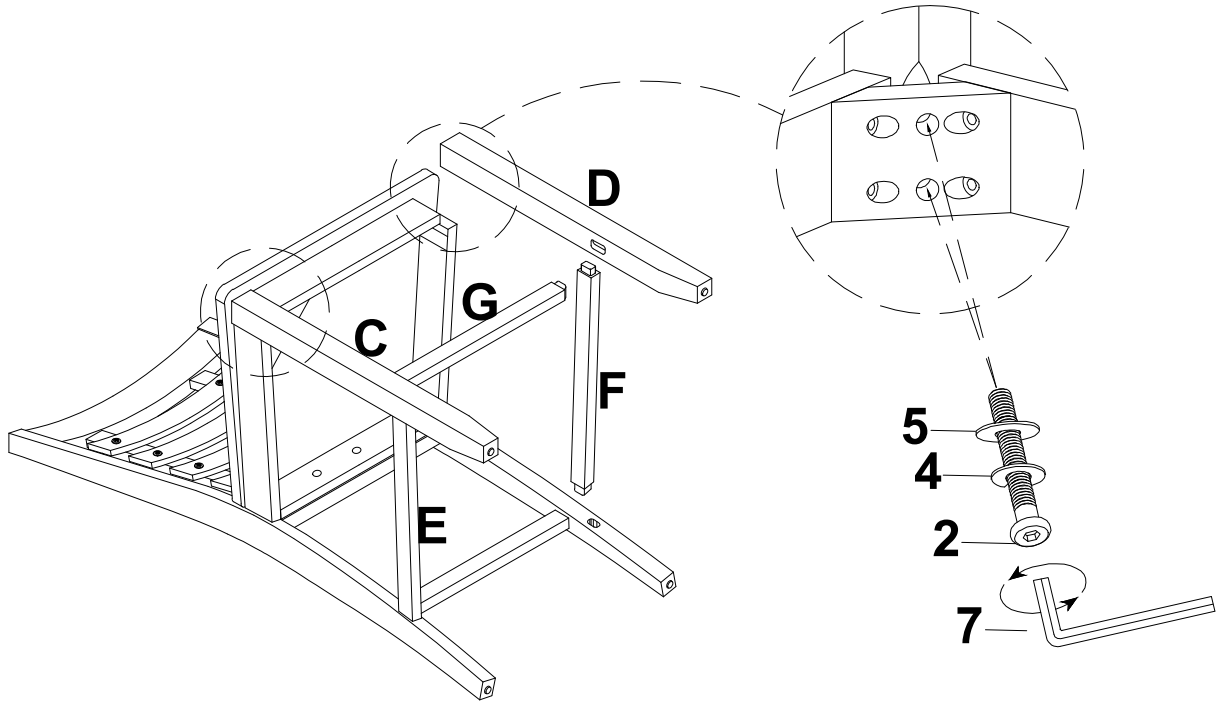

STEP 3

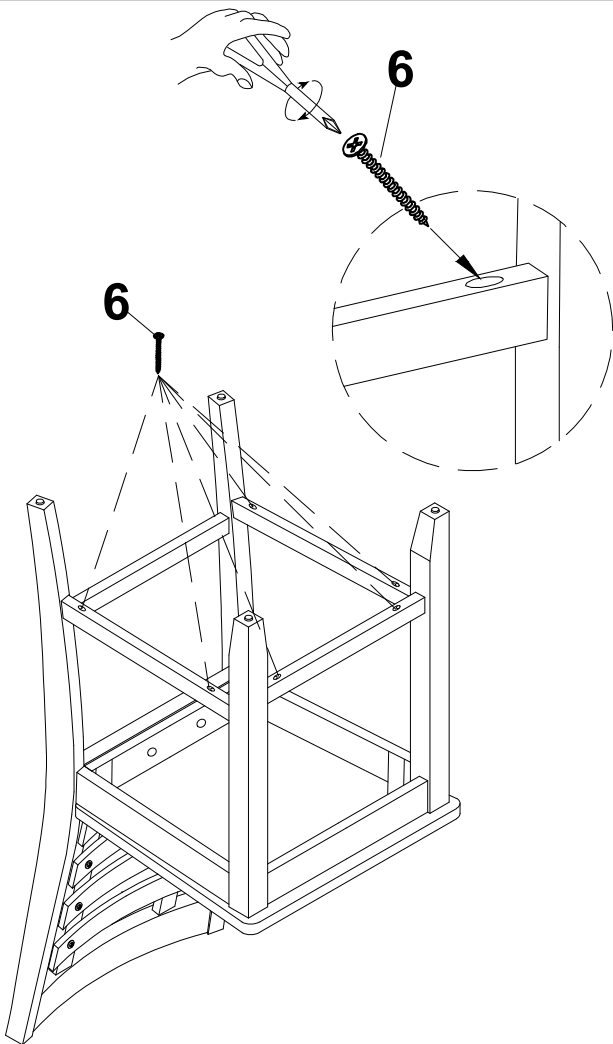

COMPLETE

