

# ASSEMBLY INSTRUCTIONS

## DINING TABLE

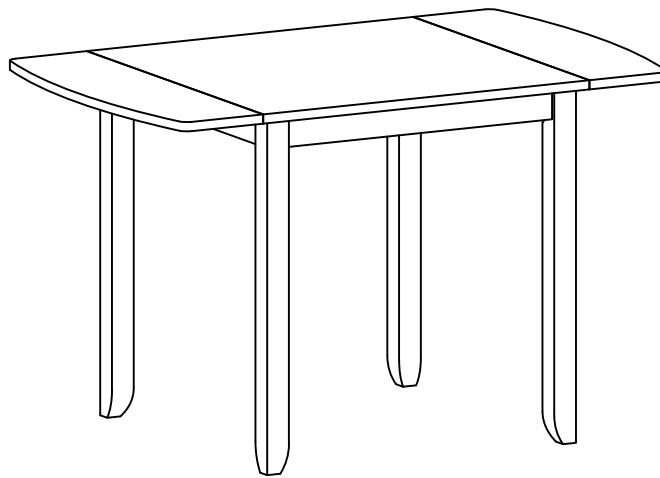

**WF308166**

### **IMPORTANT NOTE:**

- PLACE ALL PARTS ON A CLEAN AND SMOOTH SURFACE SUCH AS A RUG OR CARPET TO AVOID THE PARTS FROM BEING SCRATCHED.
- BEFORE YOU BEGIN, KINDLY FOLLOW THE ASSEMBLY INSTRUCTIONS STEP BY STEP.
- DO NOT TIGHTEN ALL SCREWS AND BOLTS UNTIL THE TABLE IS FULLY SET-UP.

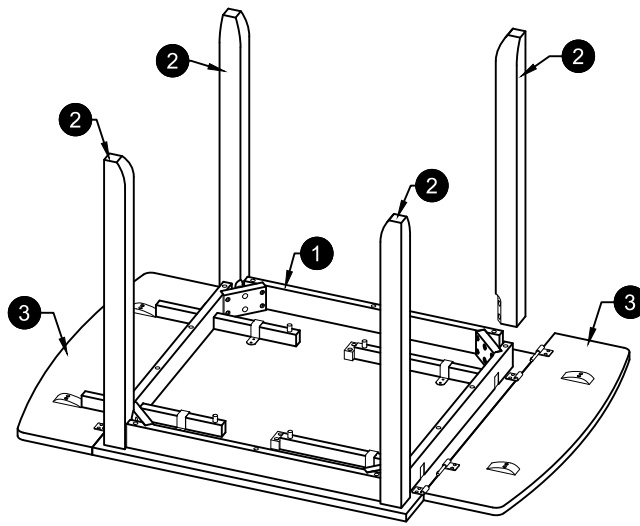

**CARTON CONTENT:**

WF308166 :

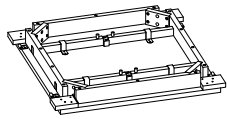

1 x 1



2 x 4



3 x 2

**TABLE PART LISTS**

NO.	DESCRIPTION	SKETCH	QTY
1	TABLE TOP		1 PC
2	TABLE LEG		4 PCS
3	LEAF		2 PCS

**TABLE HARDWARE LISTS**

NO.	DESCRIPTION	SKETCH	QTY
A	HEX COMB 5/16 x 2 1/2"		8 PCS
B	SPRING WASHER 5/16"		8 PCS
C	FLAT WASHER 5/16"		8 PCS
D	SPANNER 1.28		1 PC

**STEP 1**

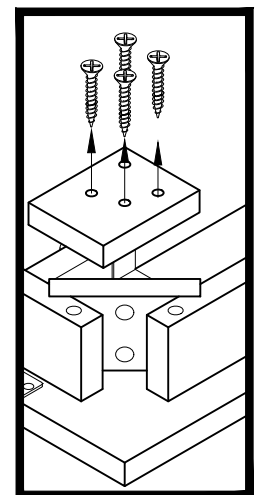
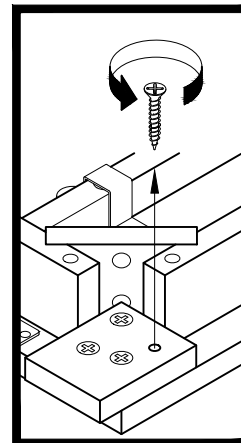
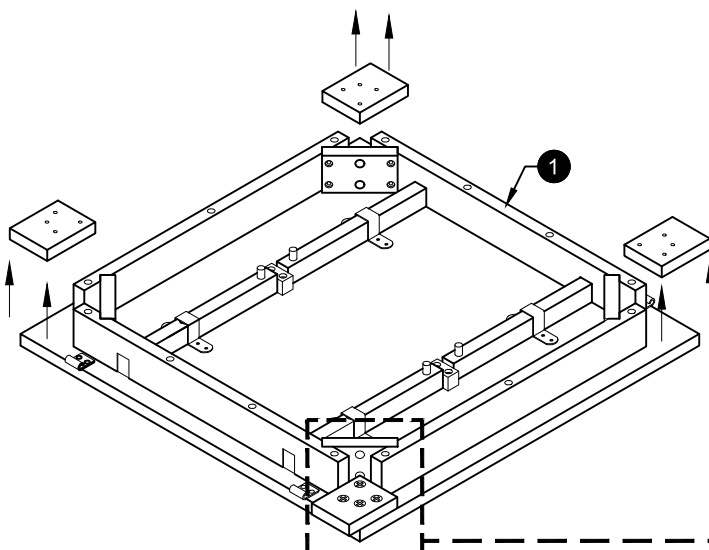

STEP 2

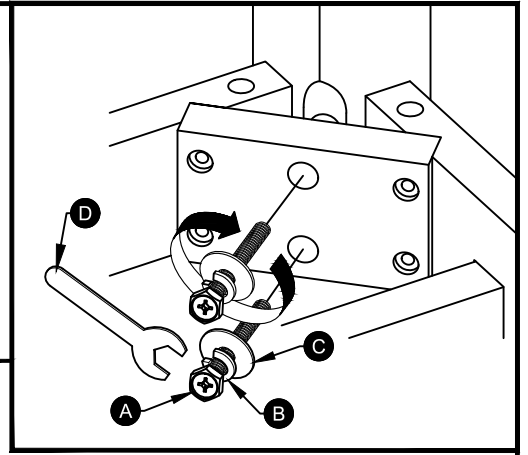
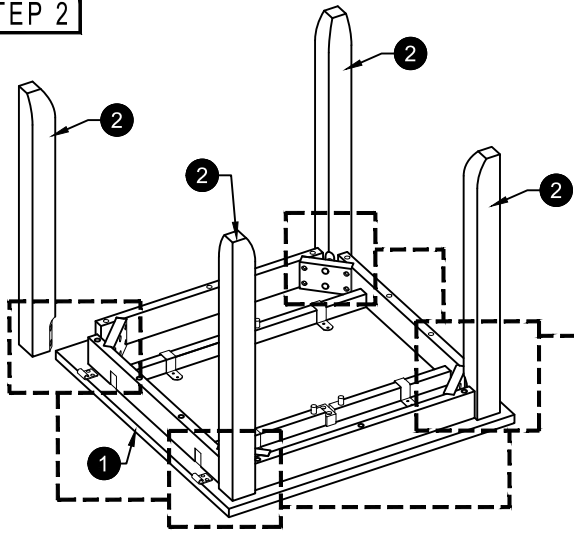

STEP 3

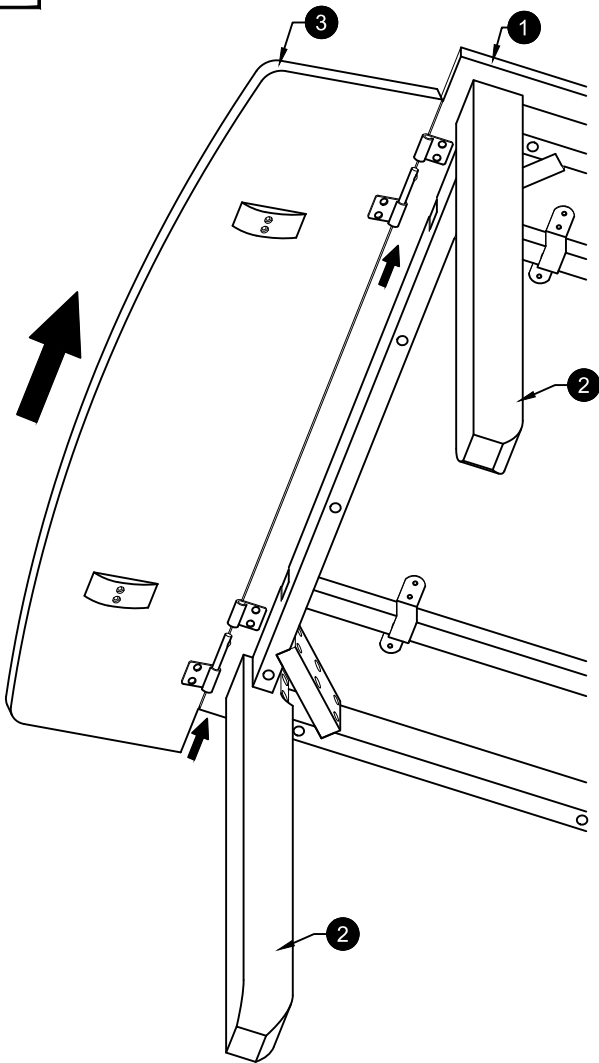

STEP 4

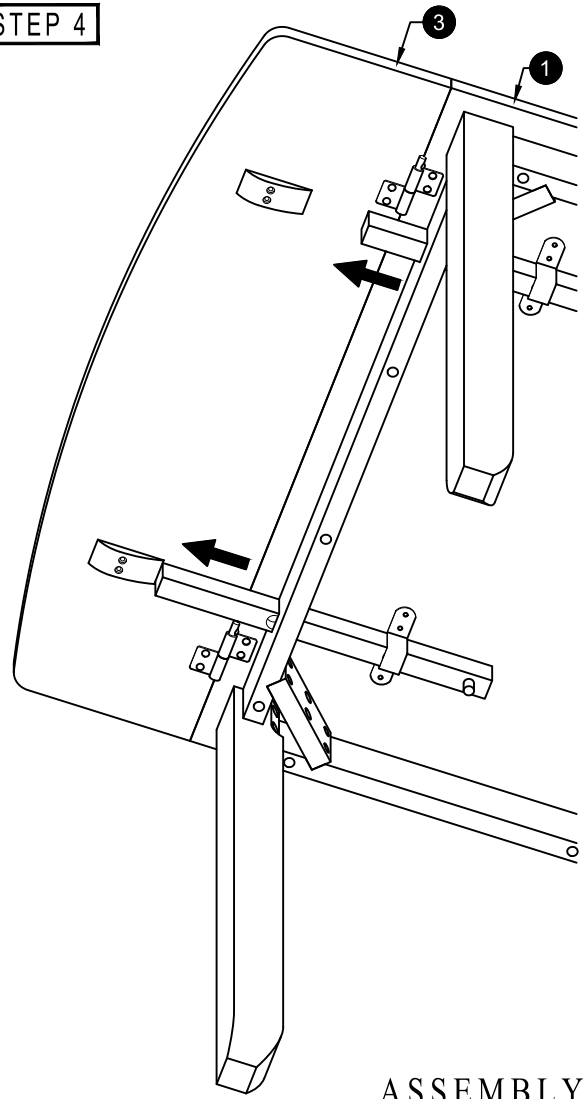

ASSEMBLY  
COMPLETE !

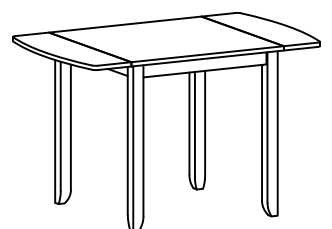

# ASSEMBLY INSTRUCTIONS

## DINING CHAIR

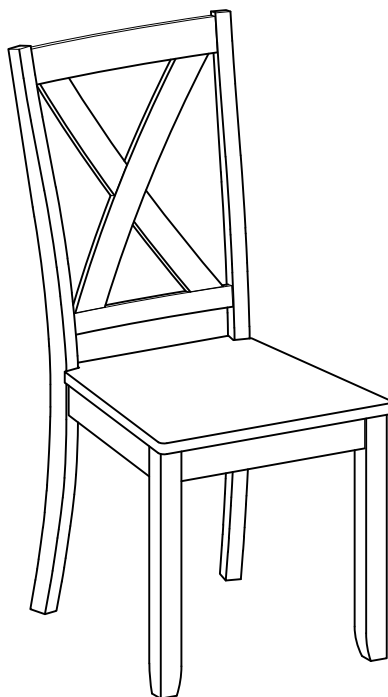

**WF308167**

### **IMPORTANT NOTE:**

- PLACE ALL PARTS ON A CLEAN AND SMOOTH SURFACE SUCH AS A RUG OR CARPET TO AVOID THE PARTS FROM BEING SCRATCHED.
- BEFORE YOU BEGIN, KINDLY FOLLOW THE ASSEMBLY INSTRUCTIONS STEP BY STEP.
- DO NOT TIGHTEN ALL SCREWS AND BOLTS UNTIL THE CHAIR IS FULLY SET-UP.

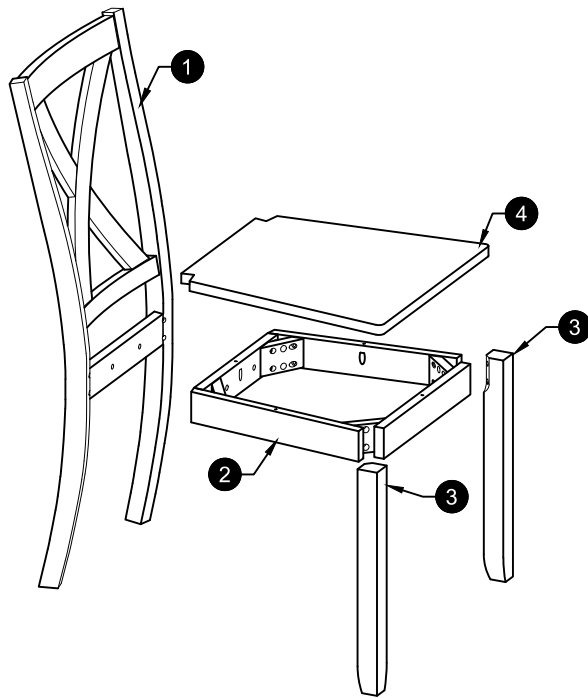

**CARTON CONTENT:**

WF308167 :

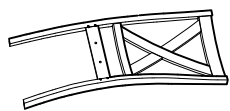

1 x 4

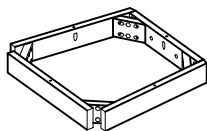

2 x 4

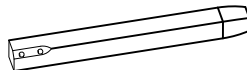

3 x 8

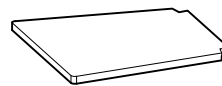

4 x 4

**CHAIR PART LISTS**

NO.	DESCRIPTION	SKETCH	QTY
1	BACK LEG		4 PCS
2	BOX SEAT		4 PCS
3	FRONT LEG		8 PCS
4	SEAT		4 PCS

**CHAIR HARDWARE LISTS**

NO.	DESCRIPTION	SKETCH	QTY
A	JCBC BOLT M6 x 35mm		8 PCS
B	JCBC BOLT M6 x 60mm		16 PCS
C	JCBC BOLT M6 x 80mm		16 PCS
D	SPRING WASHER 1/4"		40 PCS
E	FLAT WASHER 1/4"		40 PCS
F	ALLEN KEY M4		1 PC
G	C/B SCREW M4 x 30mm		16 PCS

STEP 1

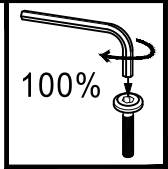
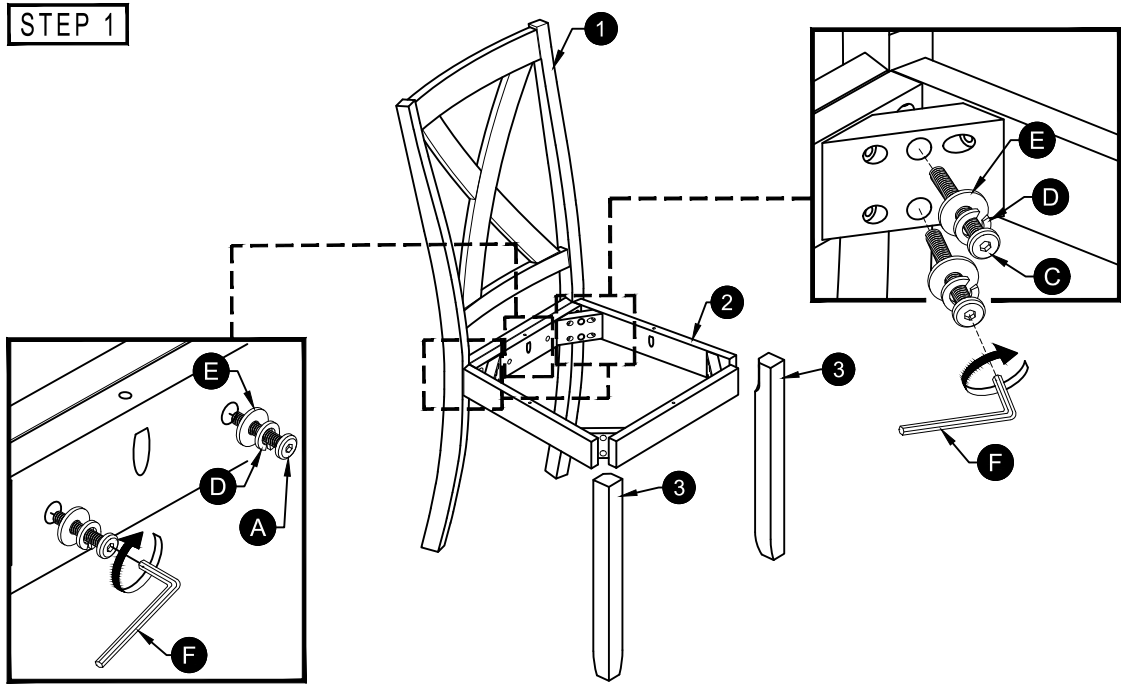

STEP 2

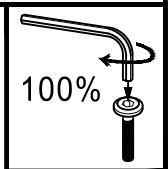
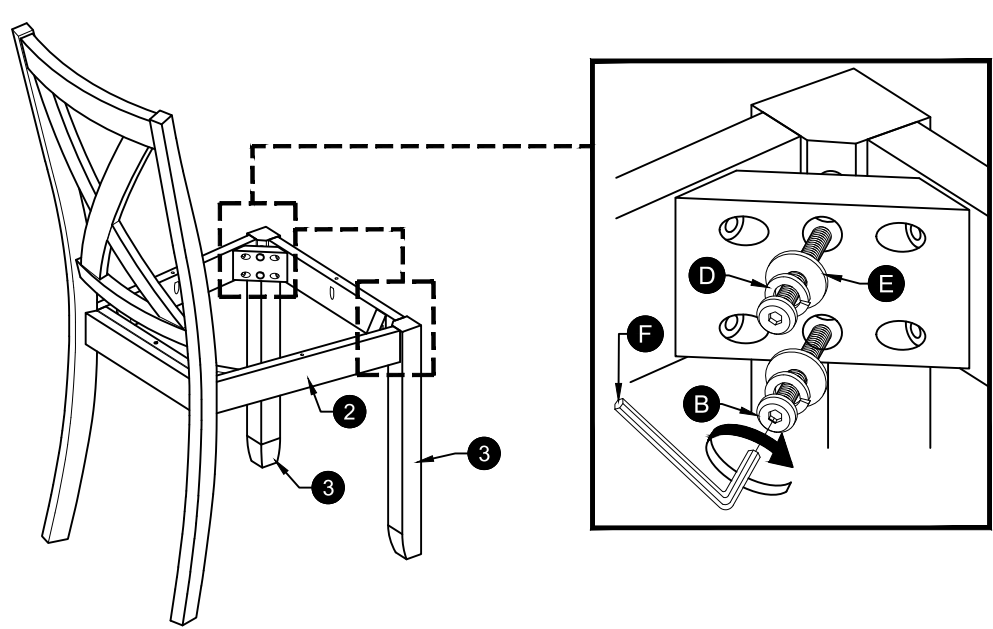

STEP 3

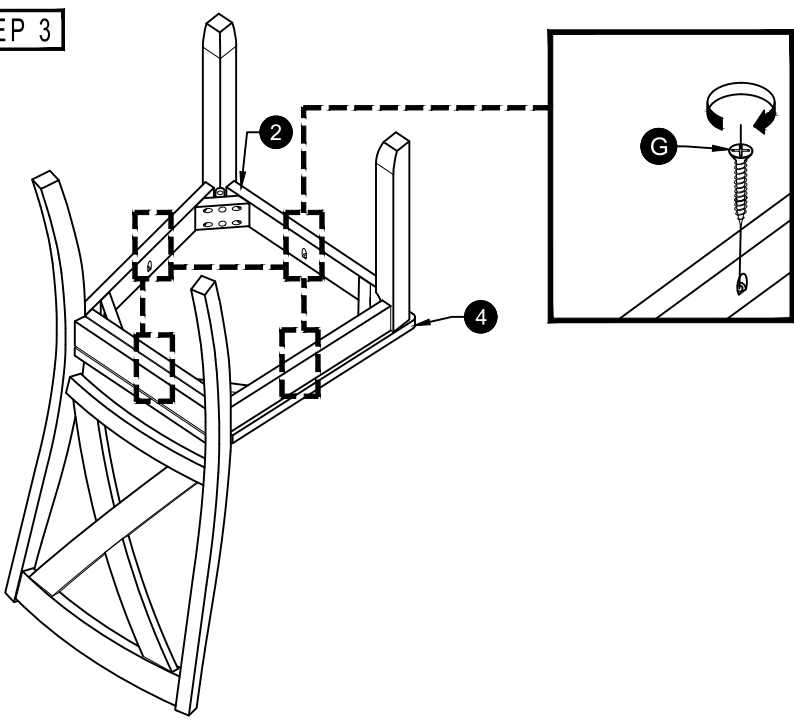

ASSEMBLY COMPLETE !

