

ASSEMBLY INSTRUCTION

9PCS Patio Dining Set

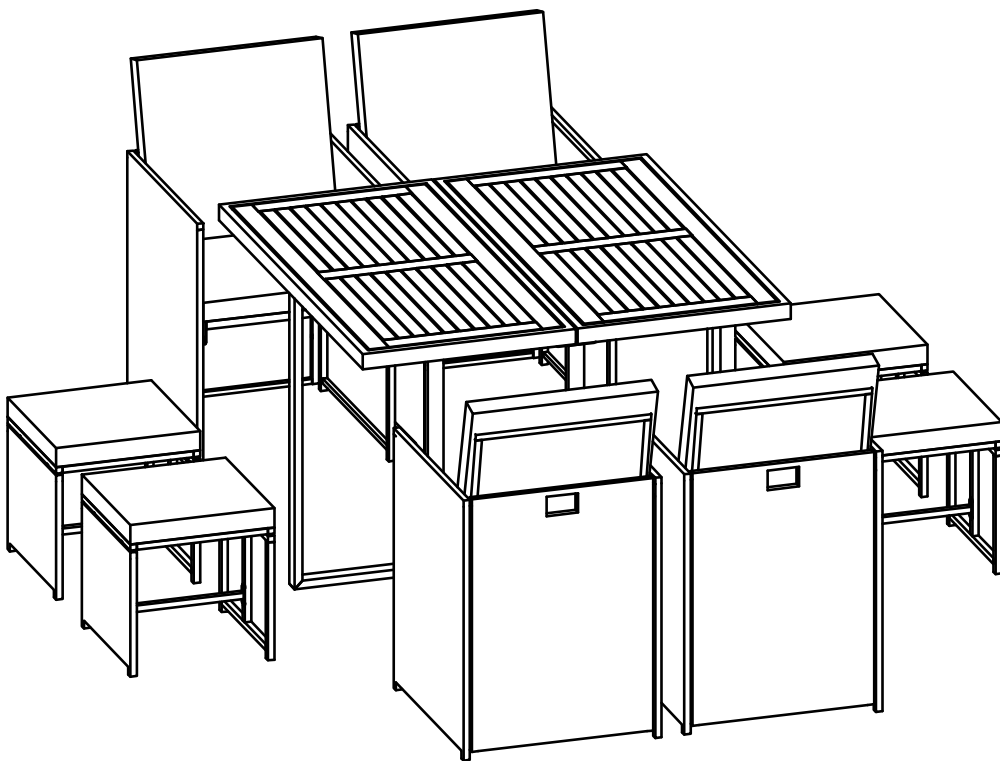

WF300001, WF300002

X1

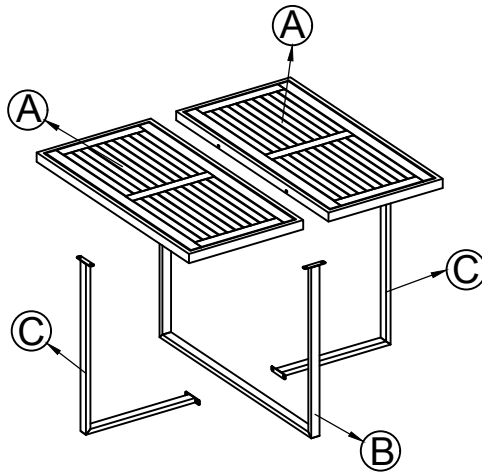

X4

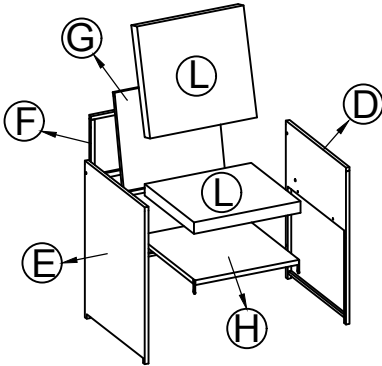

X4

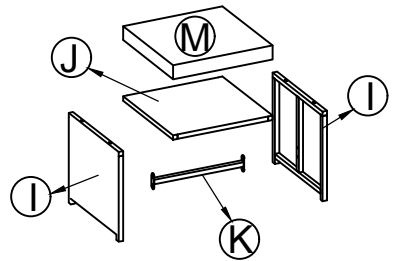

Note:

1. 50% Tighten before fixing all screws, Allen wrench is recommended instead of an electric drill.
2. Place the item on a flat ground to adjust and make sure it remains stable.
3. Tighten up all screw with tools gradually.
4. If screw are not aligned with holes during assembly, please loosen all the other screws to 50% and continue the assembly process.
5. If the item is not stable, please loosen all screws, adjust it on a flat ground and tighten up all screws again.
6. Note: If one or some screws are fully tighten during assembly, chances are the others will not be aligned with holes. In addition, all the holes are designed to be relatively larger to provide more space for the adjustment of the screws.

CARTON CONTENT:

WF300001

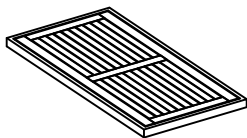

Ⓐ x2



Ⓑ x1

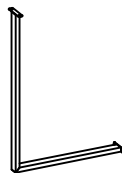

Ⓒ x2

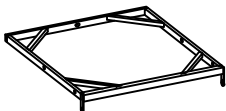

Ⓗ x4

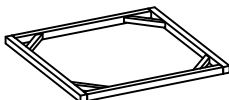

Ⓙ x4

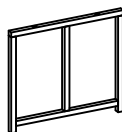

Ⓛ x4



Ⓚ x4

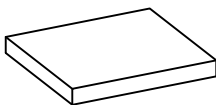

Ⓛ x8

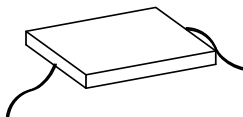

Ⓜ x4

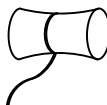

Hardware

WF300002

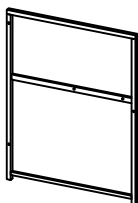

Ⓓ x4

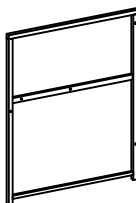

Ⓔ x4

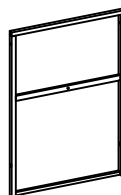

Ⓕ x4

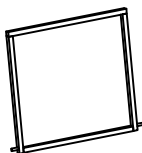



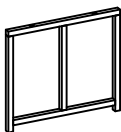





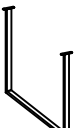

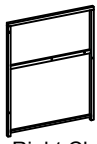
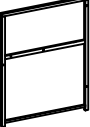
Ⓖ x4







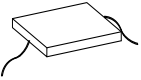



Ⓛ x4

Part List:

<p>(A)x2</p>  <p>Top Table</p>	<p>(B)x1</p>  <p>Leg Table</p>	<p>(C)x2</p>  <p>Side Leg Table</p>	<p>(D)x4</p>  <p>Arm Right Chair</p>
<p>(E)x4</p>  <p>Arm Left Chair</p>	<p>(F)x4</p>  <p>Behind Chair</p>	<p>(G)x4</p>  <p>Back Chair</p>	<p>(H)x4</p>  <p>Seat Chair</p>
<p>(I)x8</p>  <p>Leg Stool</p>	<p>(J)x4</p>  <p>Seat Stool</p>	<p>(K)x4</p>  <p>Support Stool</p>	<p>(L)x8</p>  <p>Chair Cushion</p>
<p>(M)x4</p>  <p>Seat Stool Cushion</p>			

Hardware List:

<p>① x 36 pcs Extra 2 pcs</p>  <p>BOLT M6 x 20MM</p>	<p>② x 16 pcs Extra 2 pcs</p>  <p>BOLT M6 x 30MM</p>	<p>③ x 36 pcs Extra 2 pcs</p>  <p>BOLT M6 x 40MM</p>	<p>④ x 2 pcs Extra 1 pcs</p>  <p>BOLT M6 x 55MM</p>
<p>⑤ x 100 pcs</p>  <p>WASHER M6</p>	<p>⑥ x 2 pcs</p>  <p>Nut M6</p>	<p>⑦ x 2 pcs</p>  <p>ALLEN KEY</p>	<p>⑧ x 1 pcs</p>  <p>KEY</p>

STEP 1

- F** x 1
- E** x 1
- 3** x 2
- 5** x 2

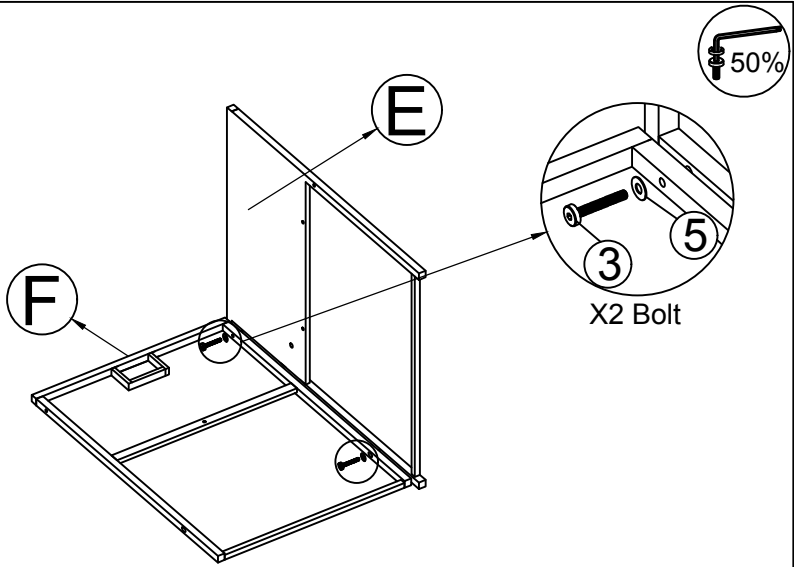

Connect The Arm Right Chair (E) & Behind Chair (F), tighten Bolt (3), Flat Washer (5) with Allen Key (7).

STEP 2

- G** x 1

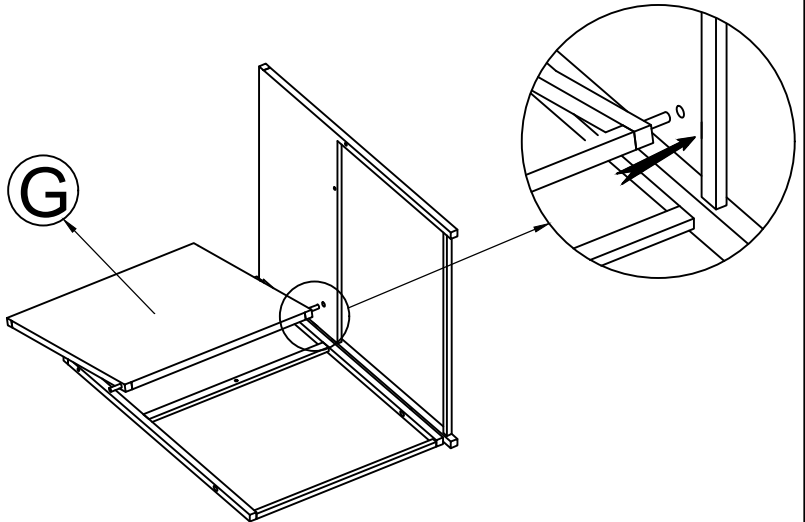

Connect The Part from STEP 1 & Back Chair (G).

STEP 3

- ⓓ x 1
- ③ x 2
- ⑤ x 2

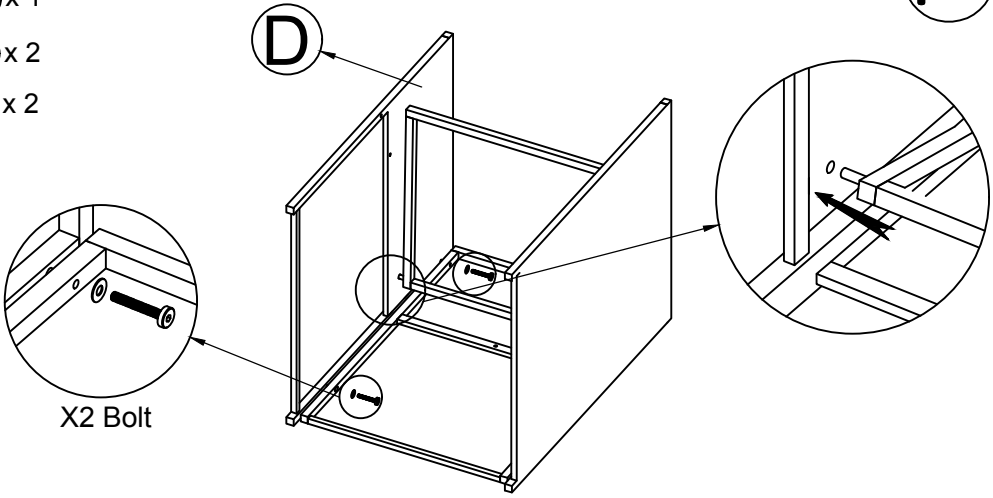

X2 Bolt

Connect The Part from STEP 2 & Arm Right Chair (D), tighten Bolt (3), Flat Washer (5) with Allen Key (7).

STEP 4

- ⓓ x 1
- ① x 2
- ③ x 5
- ⑤ x 7

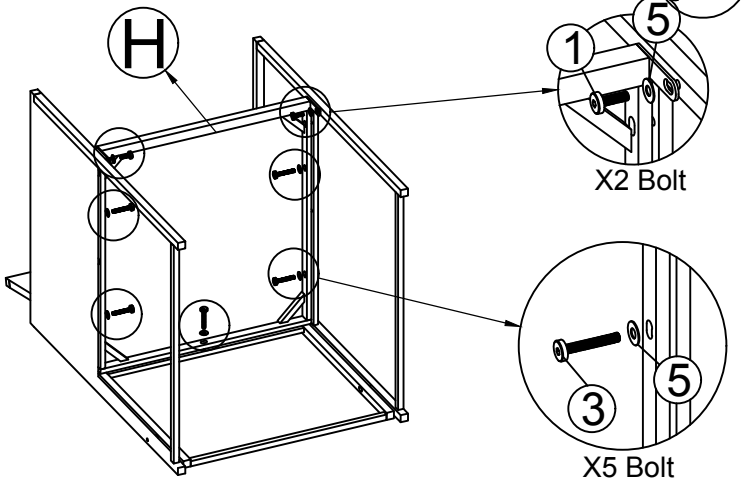

X2 Bolt

X5 Bolt

Connect The Part from STEP 3 & Seat Chair (H), tighten Bolt (1),(3), Flat Washer (5) with Allen Key (7).

STEP 5

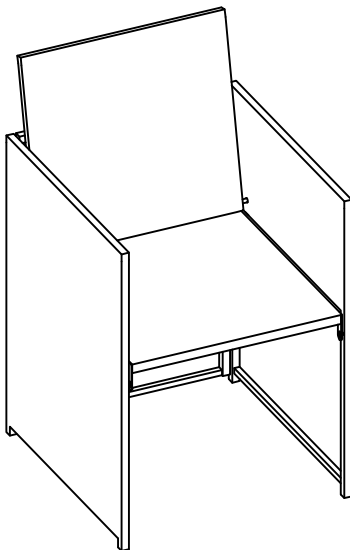

Put the Chair upright and make sure all legs are level, then firmly tighten Bolts with Allen Key (7)

STEP 6

Ⓛ x 2

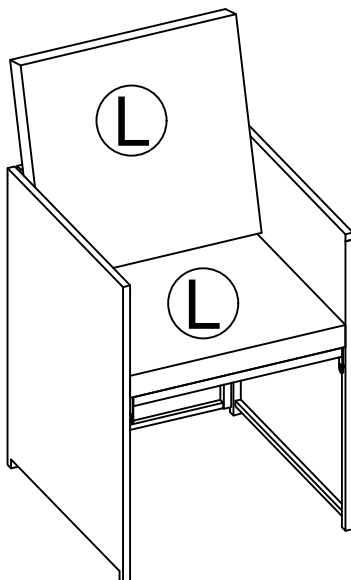

Put on Chair Cushion (L) to finish Chair.

STEP 7

- (J) x 1
- (I) x 1
- (2) x 4
- (5) x 4

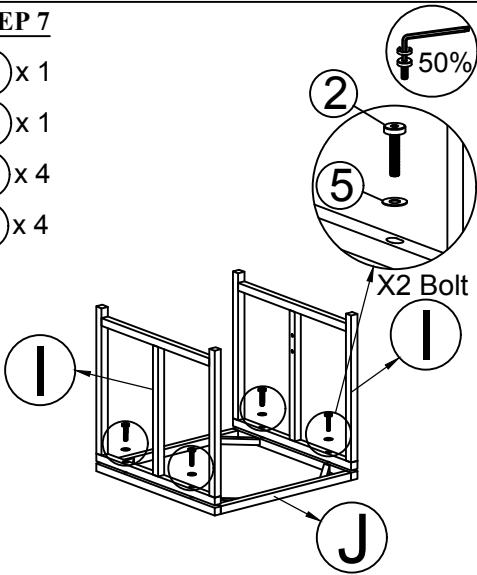

STEP 8

- (K) x 1
- (1) x 4
- (5) x 4

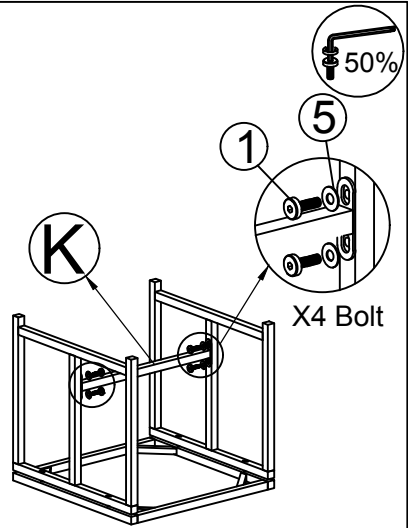

Connect The Seat Stool (J) & Leg Stool (I), tighten Bolt (2), Flat Washer (5) with Allen Key (7)

Connect The Part from STEP 7 & Support Stool (K), tighten Bolt (1), Flat Washer (5) with Allen Key (7).

STEP 9

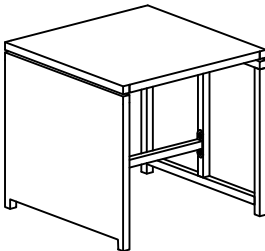

STEP 10

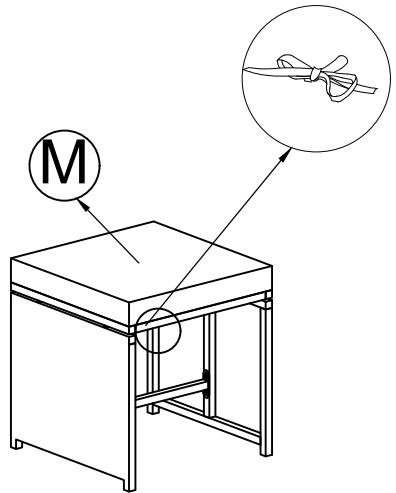

Put the Stool upright and make sure all legs are level, then firmly tighten Bolts with Allen Key (7)

Put on Seat Stool Cushion (M) & to finish Stool.

STEP 11

- Ⓐ x 2
- ④ x 2
- ⑤ x 4
- ⑥ x 2

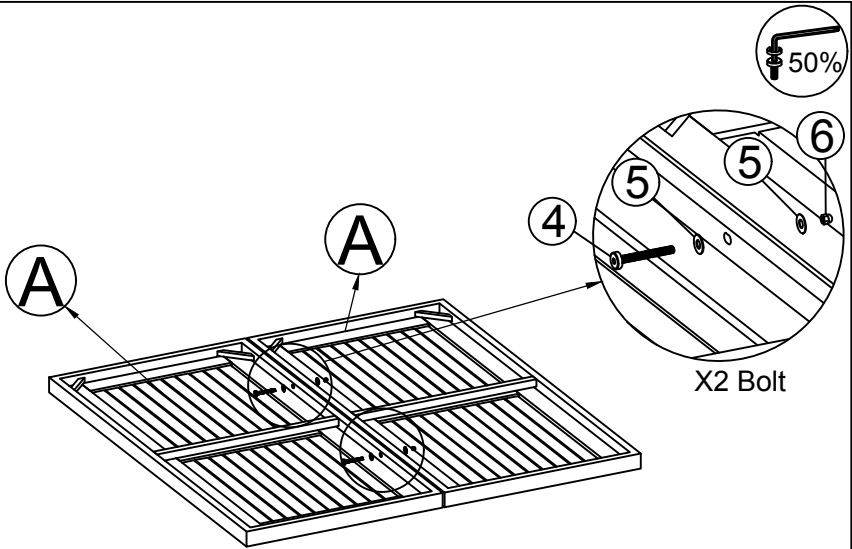

Connect The two Top Table (A), tighten Bolt (5), Flat Washer (5), Nut (6) with Allen Key (7), Key (8).

STEP 12

- Ⓑ x 1
- ① x 4
- ⑤ x 4

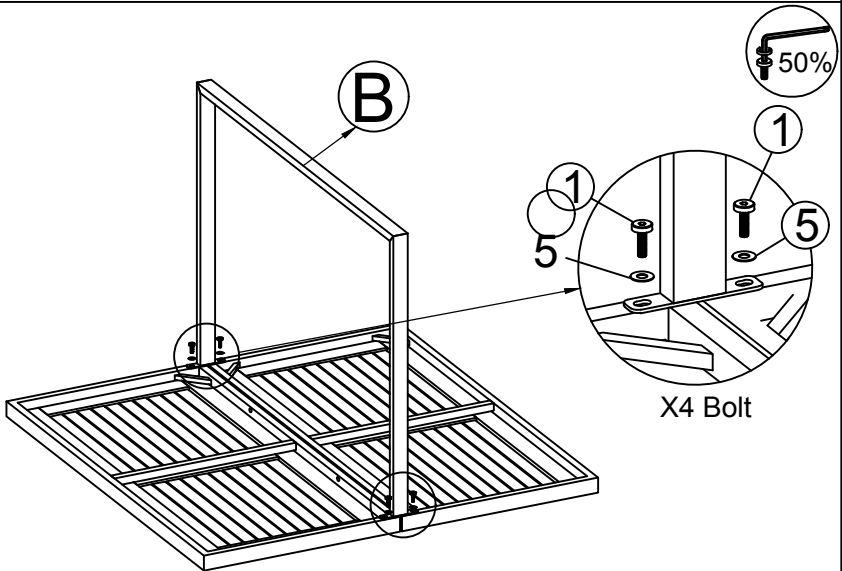

Connect The Part from STEP 11 & Leg Table (B), tighten Bolt (1), Flat Washer (5) with Allen Key (7).

STEP 13

- C** x 1
- 1** x 4
- 5** x 4

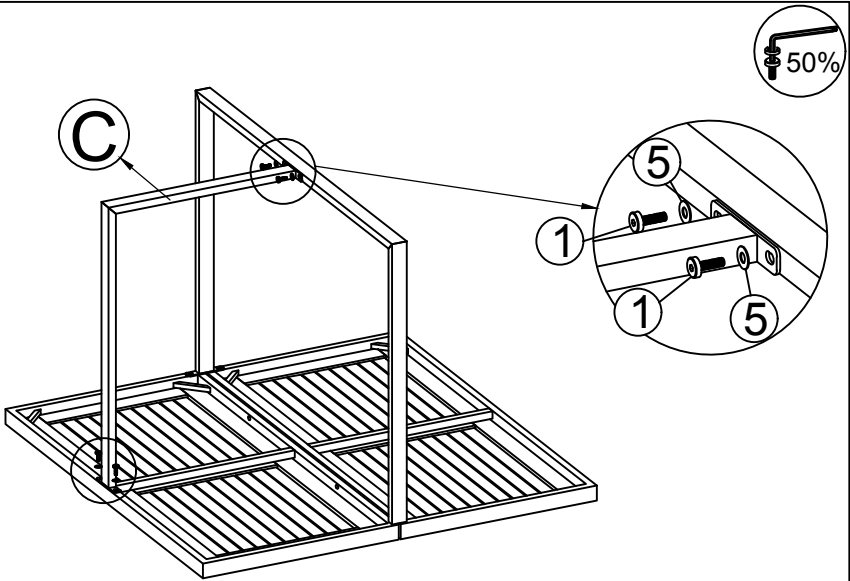

Connect The Part from Step 12 & Side leg Table (C), tighten Bolt (1), Flat Washer (5) with Allen Key (7).

STEP 14

- C** x 1
- 1** x 4
- 5** x 4

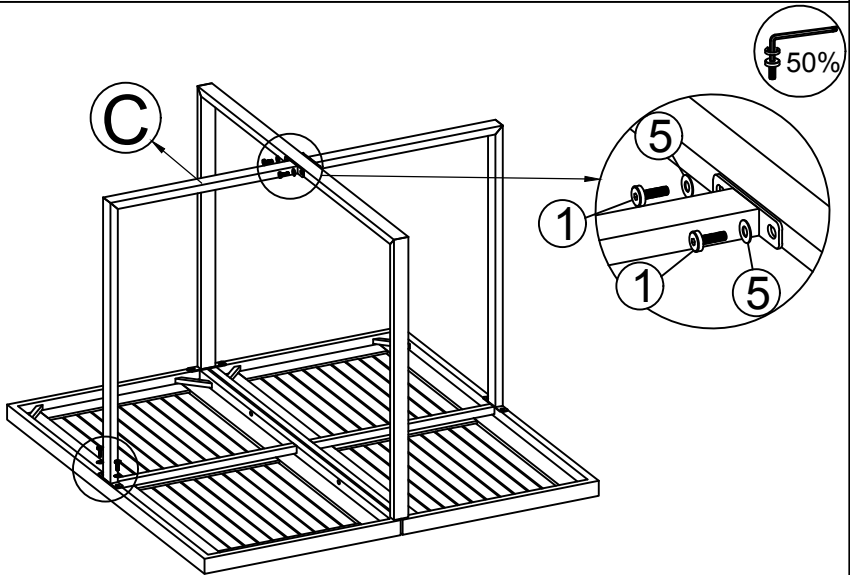

Connect The Part from STEP 13 & Side Leg Table (C), tighten Bolt (1), Flat Washer (5) with Allen Key (7).

STEP 15

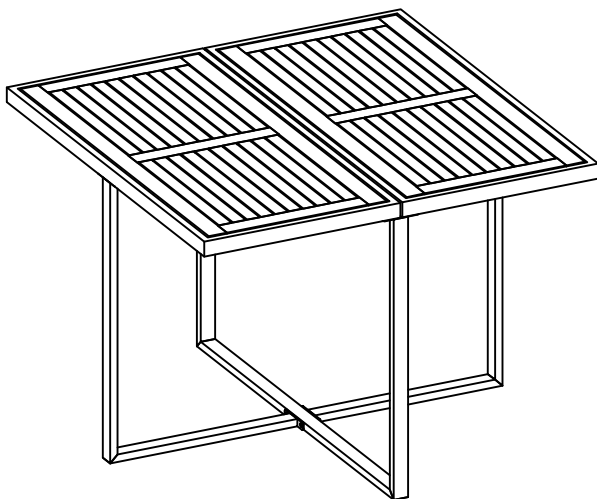

Put the Table upright and make sure all legs are level, then firmly tighten Bolts with Allen Key (7)

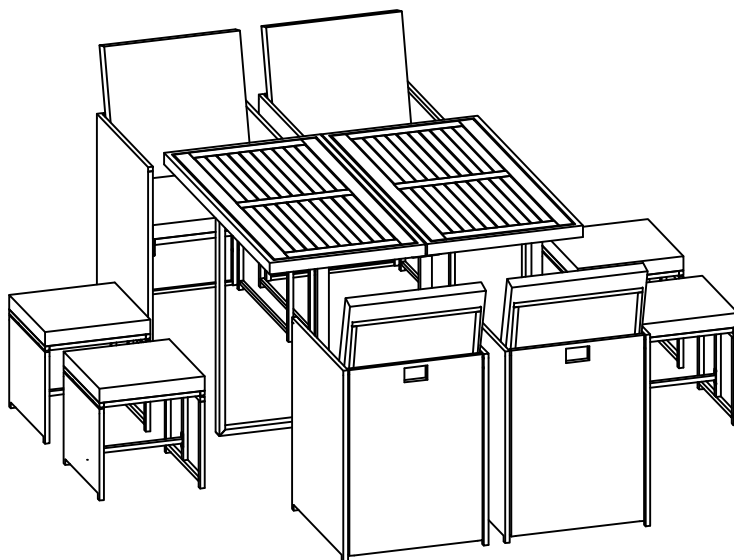

Finish