

ASSEMBLY INSTRUCTIONS

ITEM NOTE : WF297130
DINING TABLE

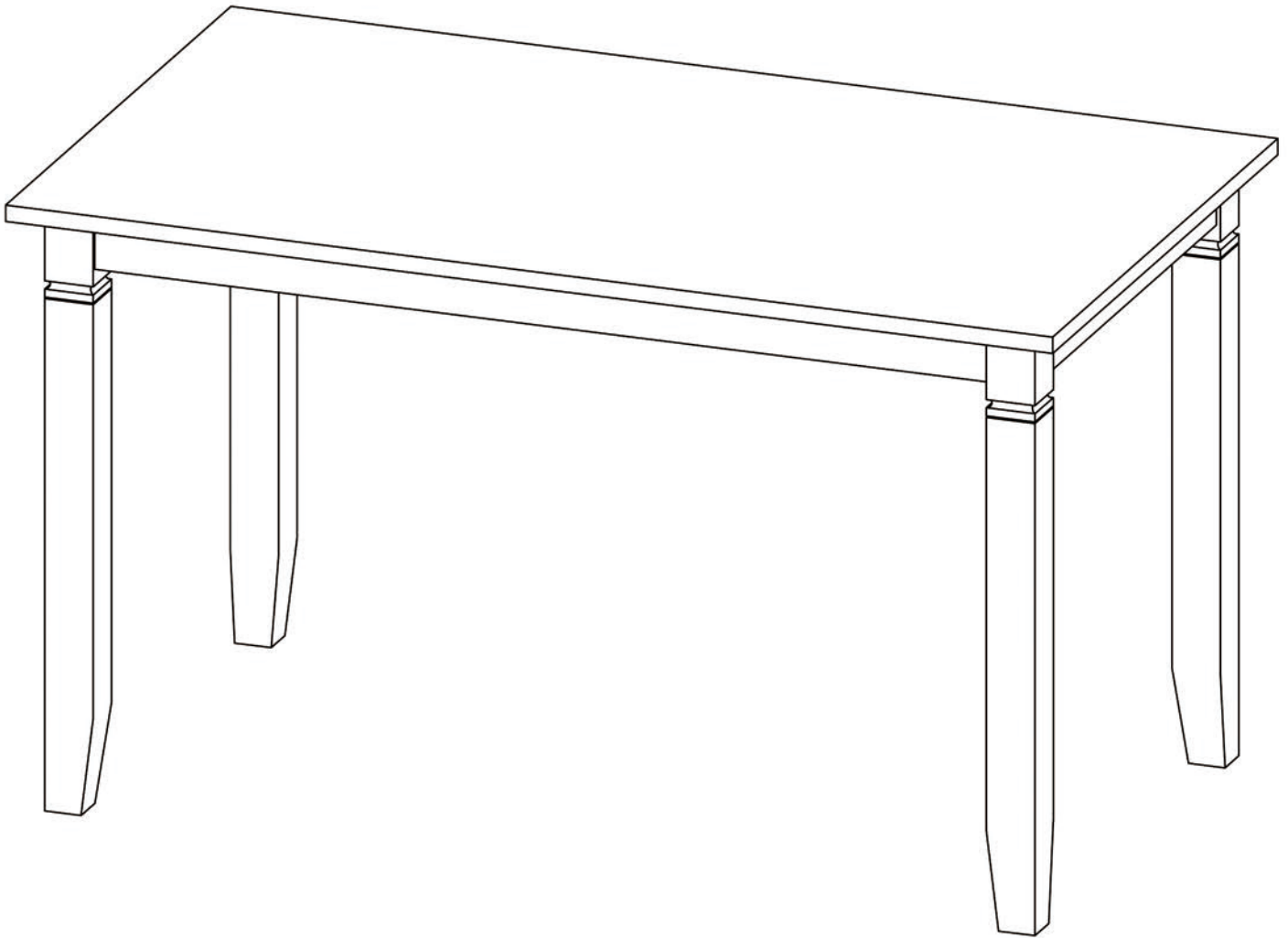





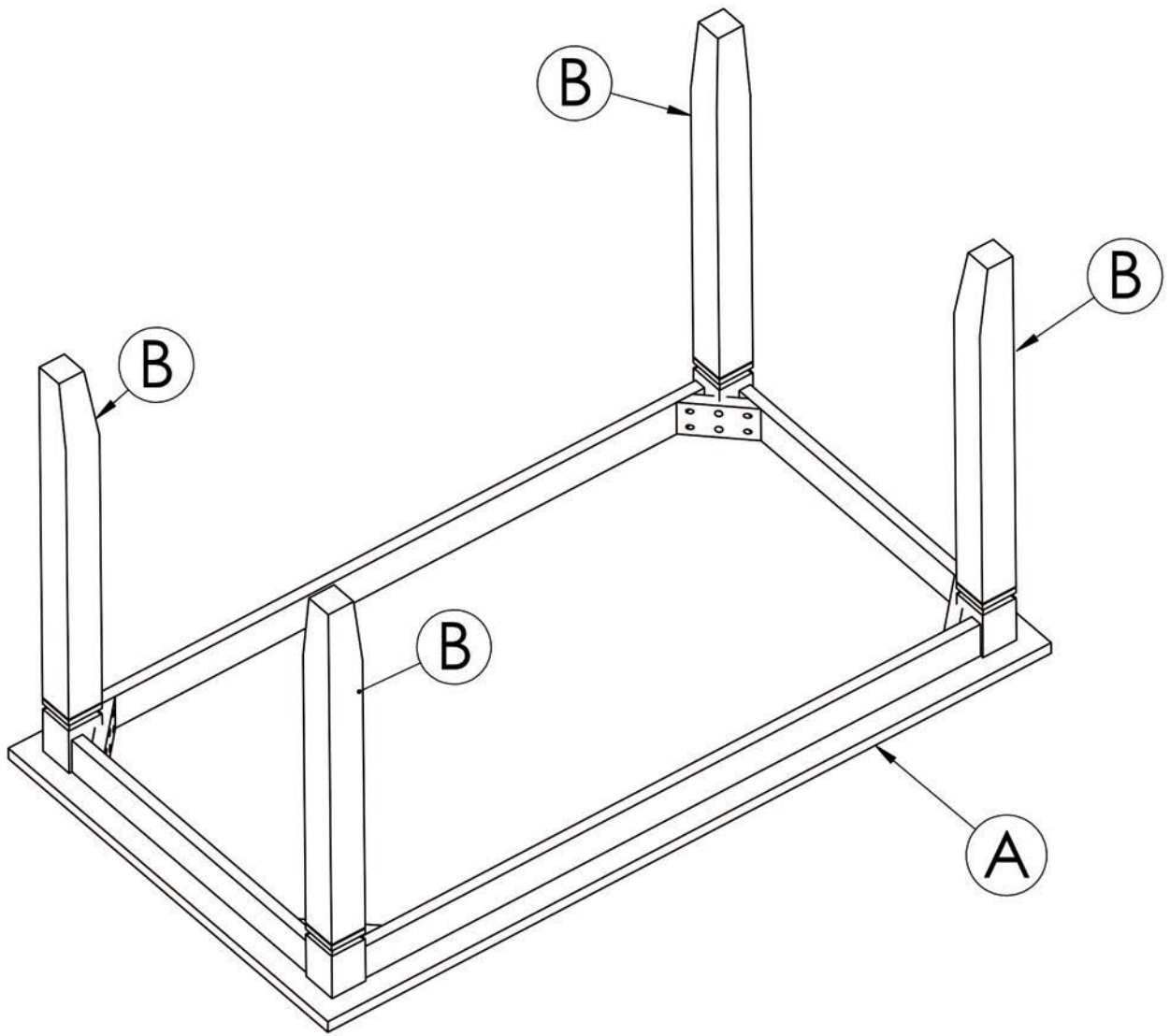

IMPORTANT NOTE :

- ① PLACE ALL PARTS ON A CLEAN AND SMOOTH SURFACE SUCH AS A RUG OR CARPET TO AVOID THE PARTS FROM BEING SCARTCHED .
- ② BEFORE YOU BEGIN , KINDLY FOLLOW THE ASSEMBLY INSTRUCTIONS STEP BY STEP
- ③ DO NOT TIGHTEN ALL SCREWS AND BOLTS UNTILL THE TABLE FULLY SET-UP

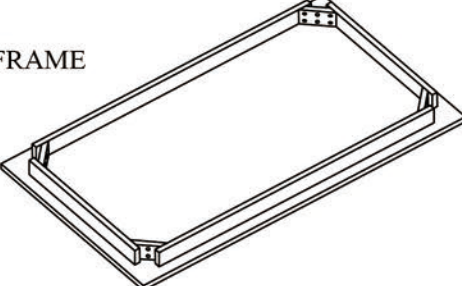

Part List For One

Hardware List For One

NO.	Part Description	Q'ty	NO.	Hardware Description	Q'ty
A	 TOP FRAME	1pc	1	Bolt 5/16 * 70 mm 	8pcs
			2	Spring Washer 5/16 * 13mm * 1.5 mm 	8pcs
B	 LEGS	4pcs	3	Flat Washer 5/16 * 16mm * 1.5 mm 	8pcs
			4	Allen Key 4mm * 60 mm 	1pc

STEP 1

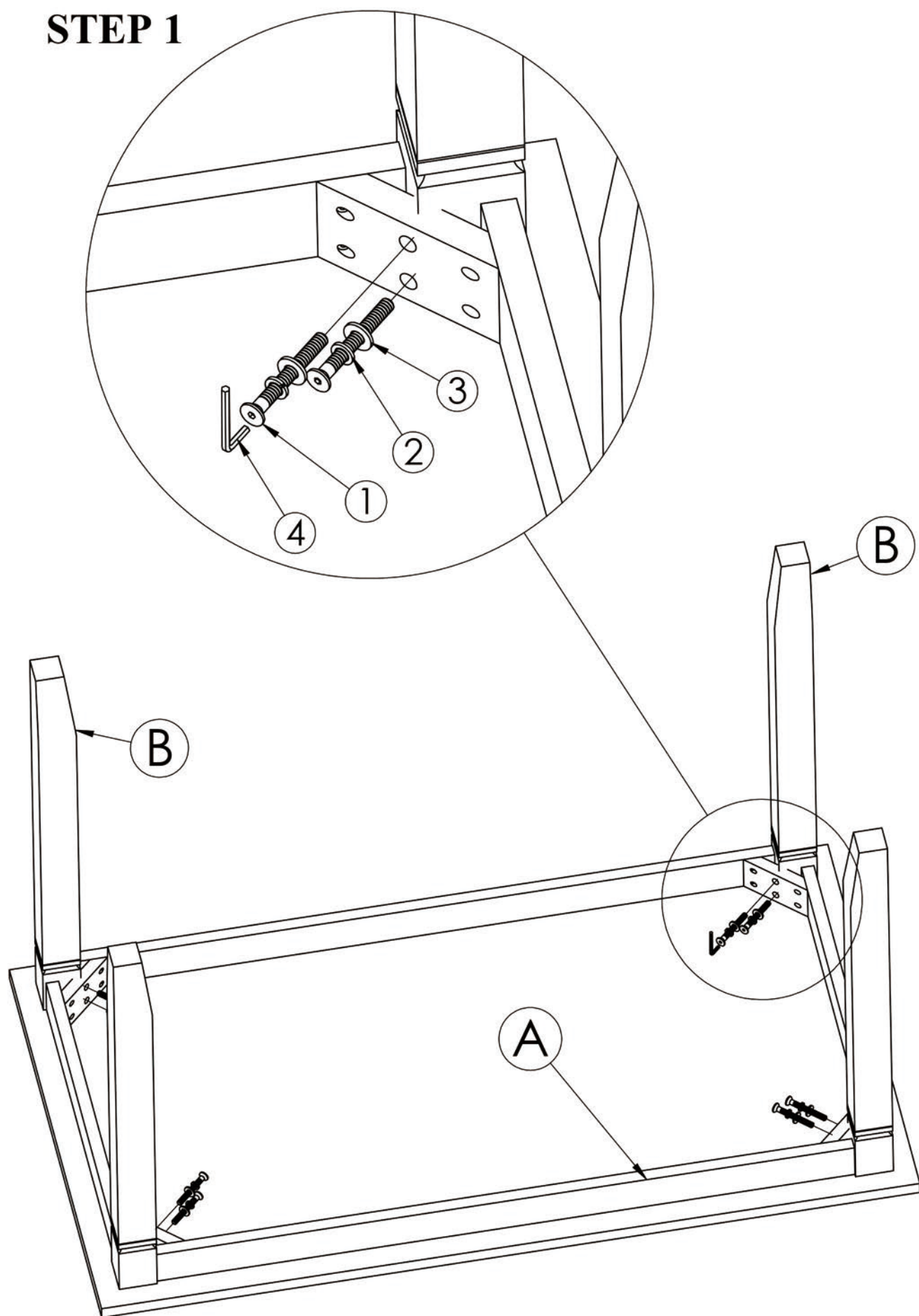

ASSEMBLY INSTRUCTIONS

ITEM NOTE : WF297131
DINING CHAIR

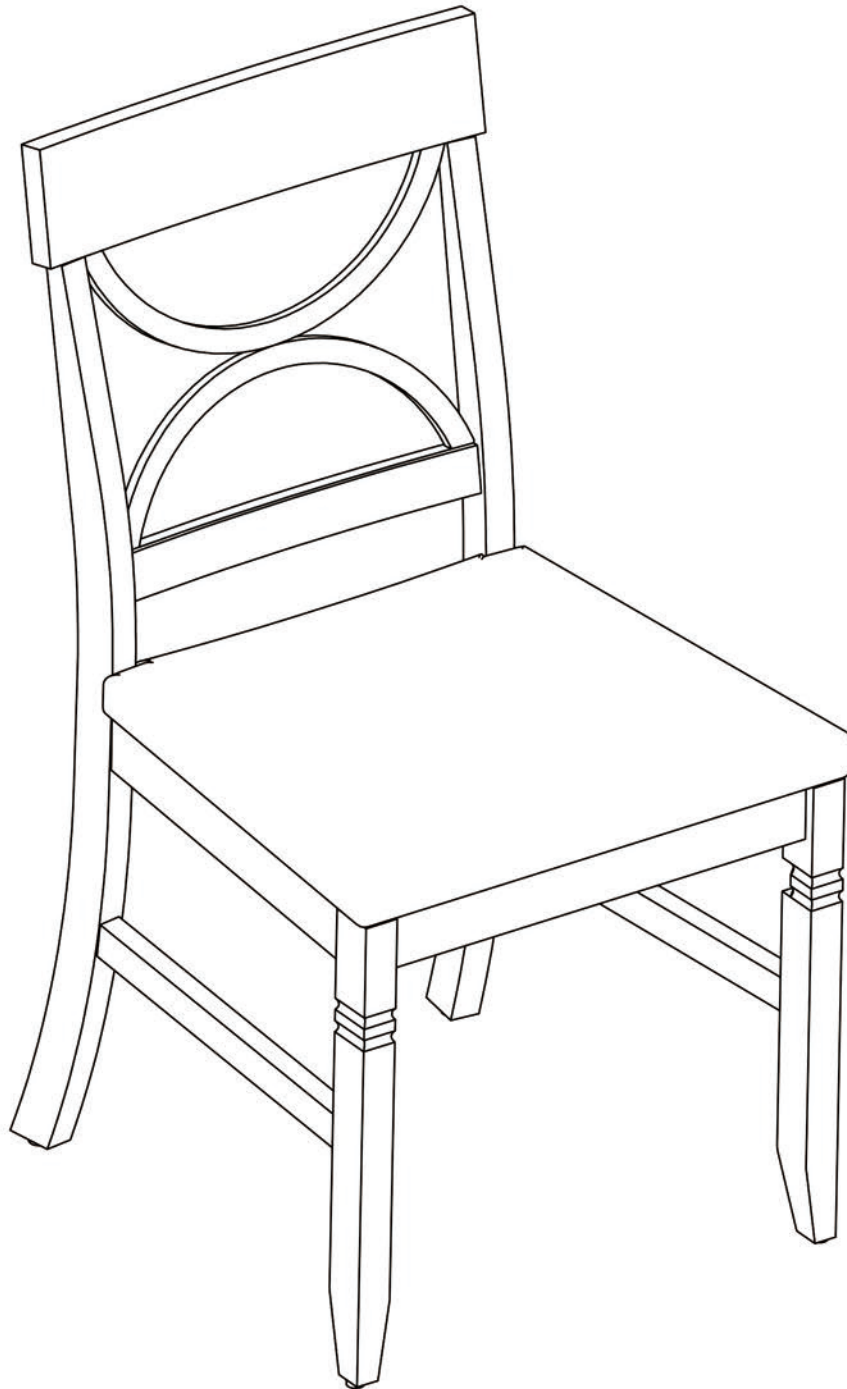





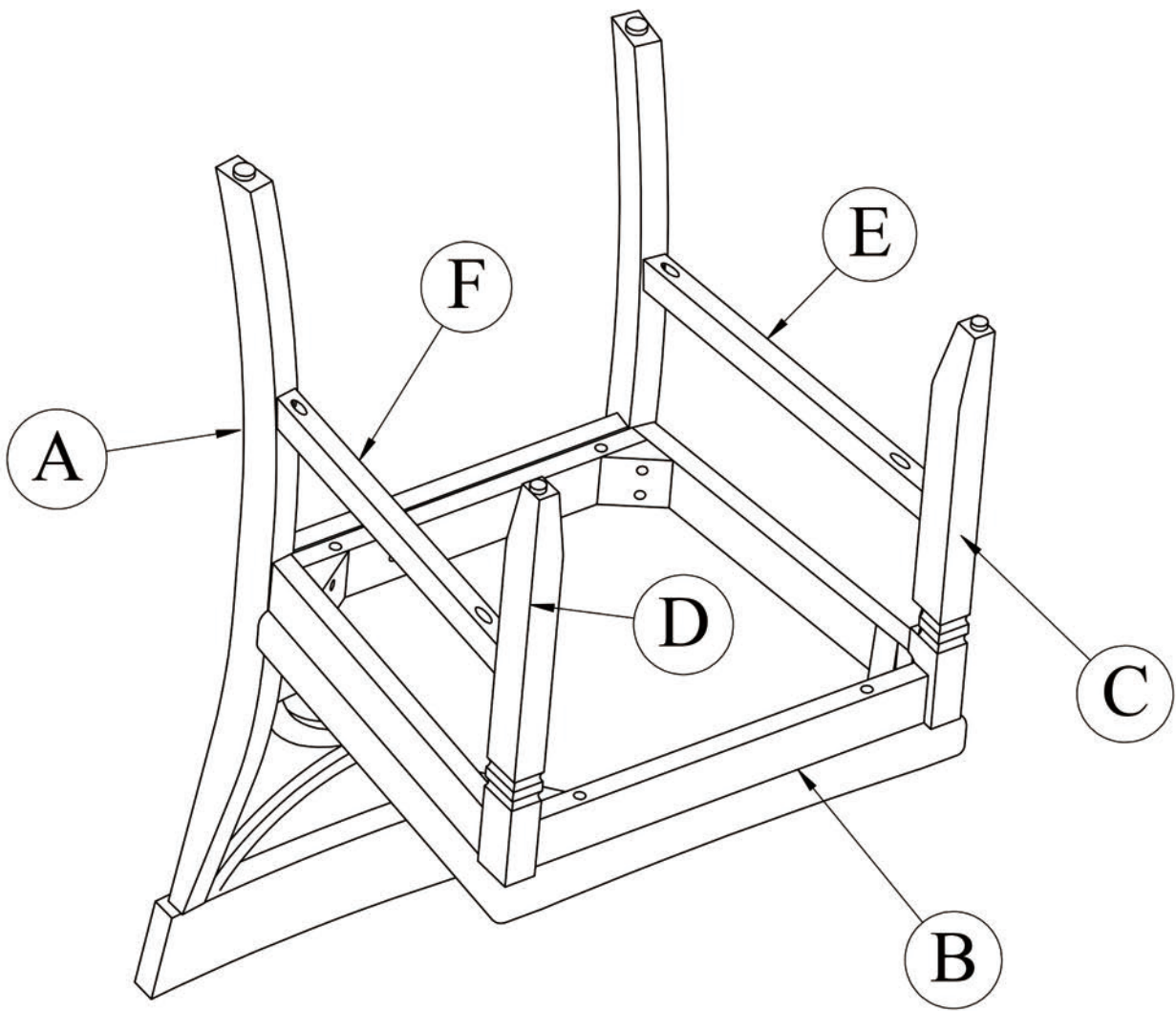





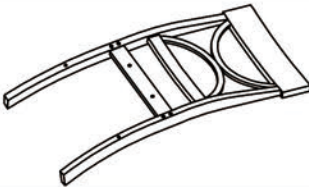

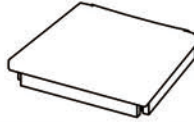
IMPORTANT NOTE :

- ① PLACE ALL PARTS ON A CLEAN AND SMOOTH SURFACE SUCH AS A RUG OR CARPET TO AVOID THE PARTS FROM BEING SCARTCHED .
- ② BEFORE YOU BEGIN , KINDLY FOLLOW THE ASSEMBLY INSTRUCTIONS STEP BY STEP
- ③ DO NOT TIGHTEN ALL SCREWS AND BOLTS UNTILL THE CHAIR FULLY SET-UP



Part List For One

Hardware List For One

NO.	Part Description	Q'ty	NO.	Hardware Description	Q'ty
A	BACK FRAME 	1pc	1	Bolt 1/4 * 35 mm 	2pcs
			2	Bolt 1/4 * 70 mm 	4pcs
B	SEAT FRAME 	1pc	3	Bolt 1/4 * 50 mm 	4pcs
			4	Spring Washer 1/4 * 11mm * 1.5 mm 	10pcs
C	FRONT LEFT LEG 	1pc	5	Flat Washer 1/4 * 16mm * 1.5 mm 	10pcs
D	FRONT RIGHT LEG 	1pc	6	Screws 4mm * 38 mm 	4pcs
E	SIDE LEFT STRETCHER 	1pc	7	Allen Key 4mm * 60 mm 	1pc
F	SIDE RIGHT STRETCHER 	1pc			

ASSEMBLY TOOLS REQUIRED (NOT INCLUDED)



STEP 1

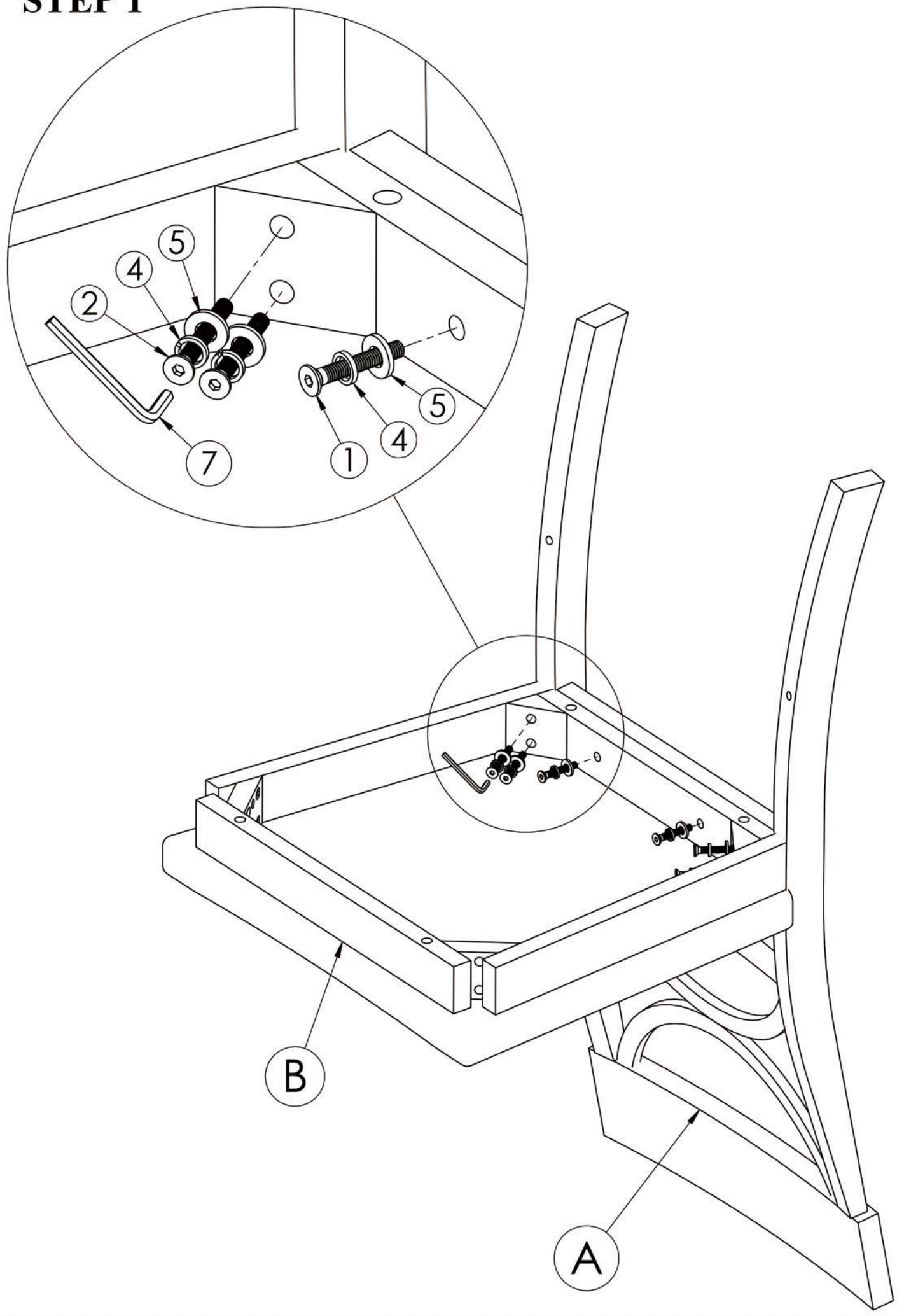

STEP 2

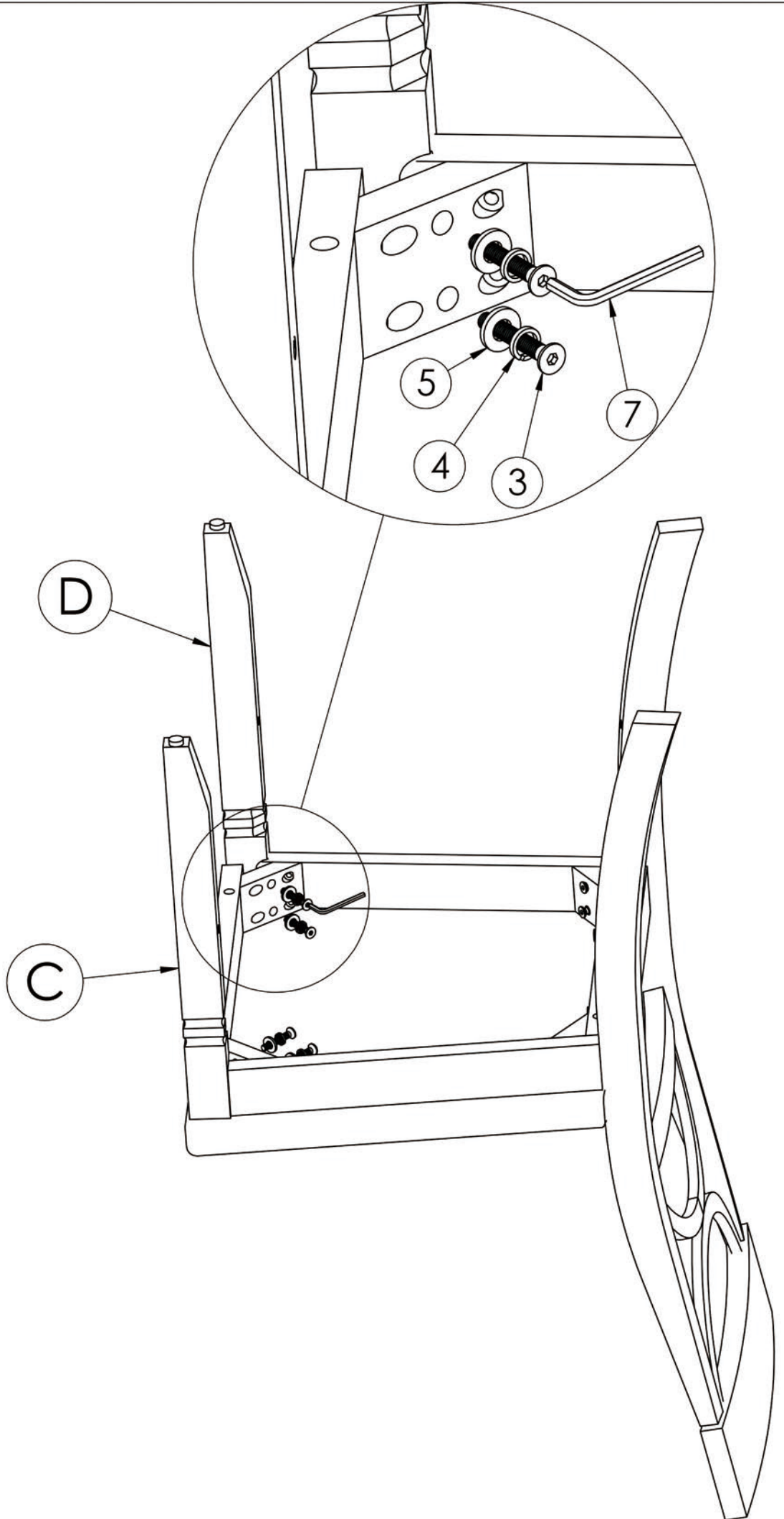

STEP 3

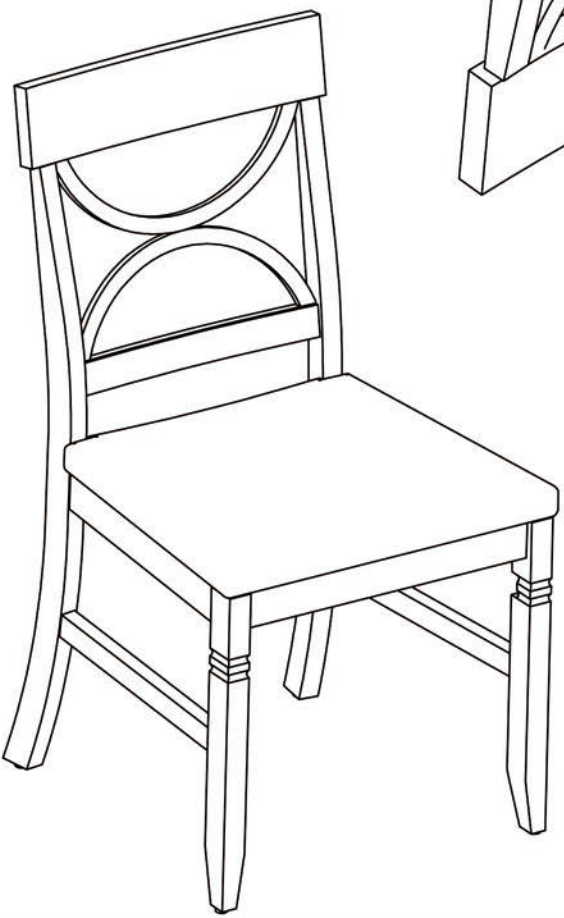
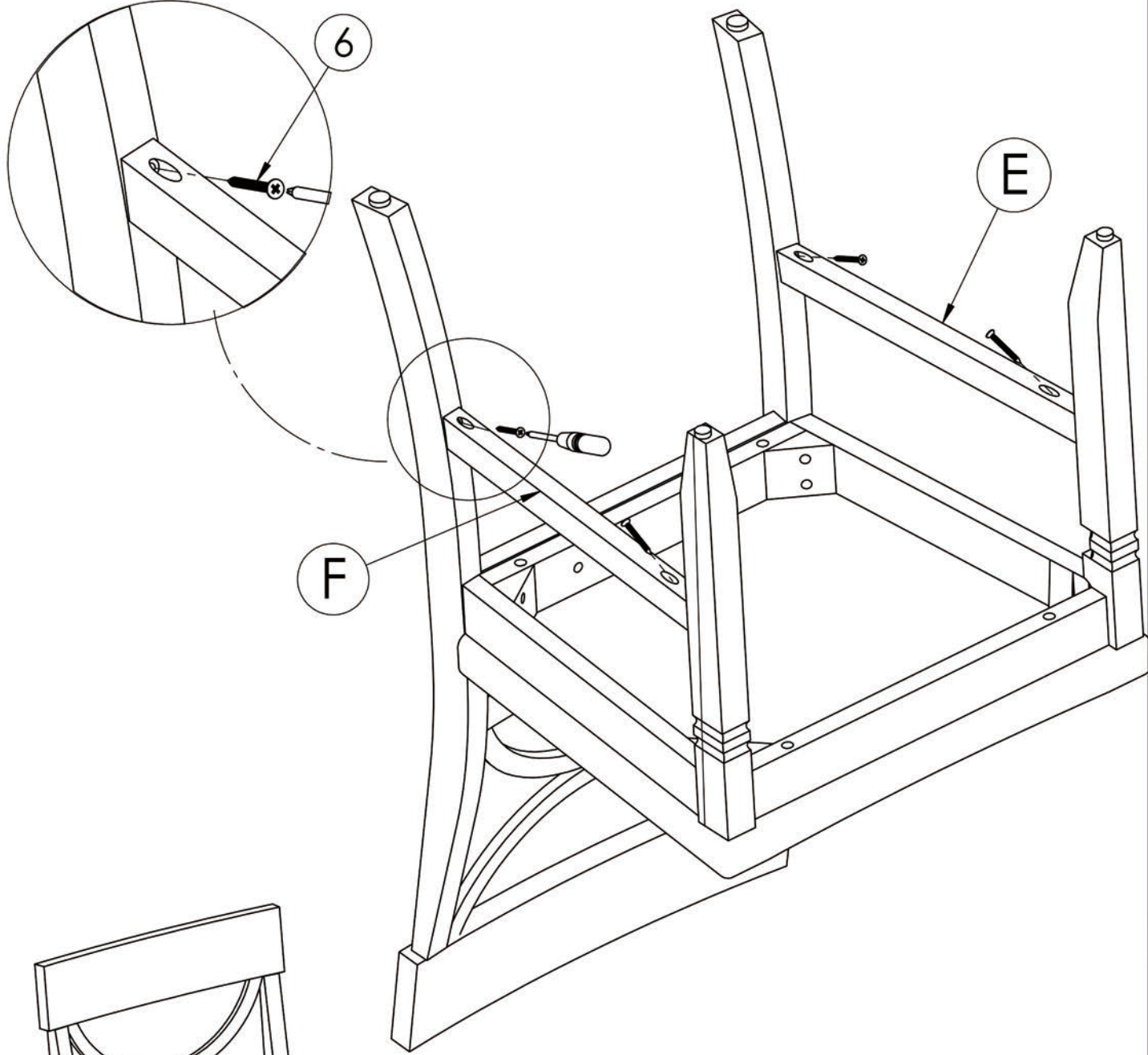

ASSEMBLY INSTRUCTIONS

ITEM NOTE : WF297131
BENCH

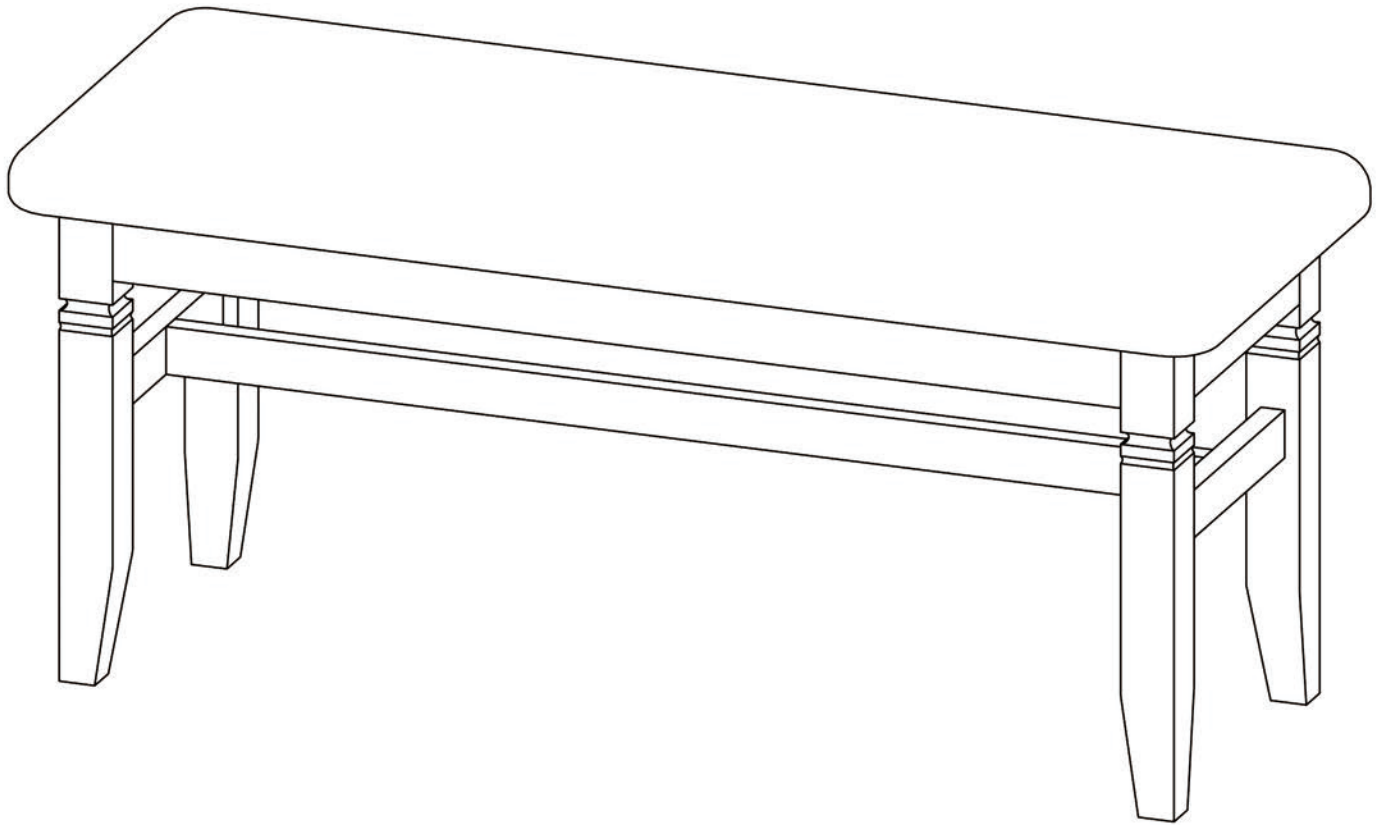





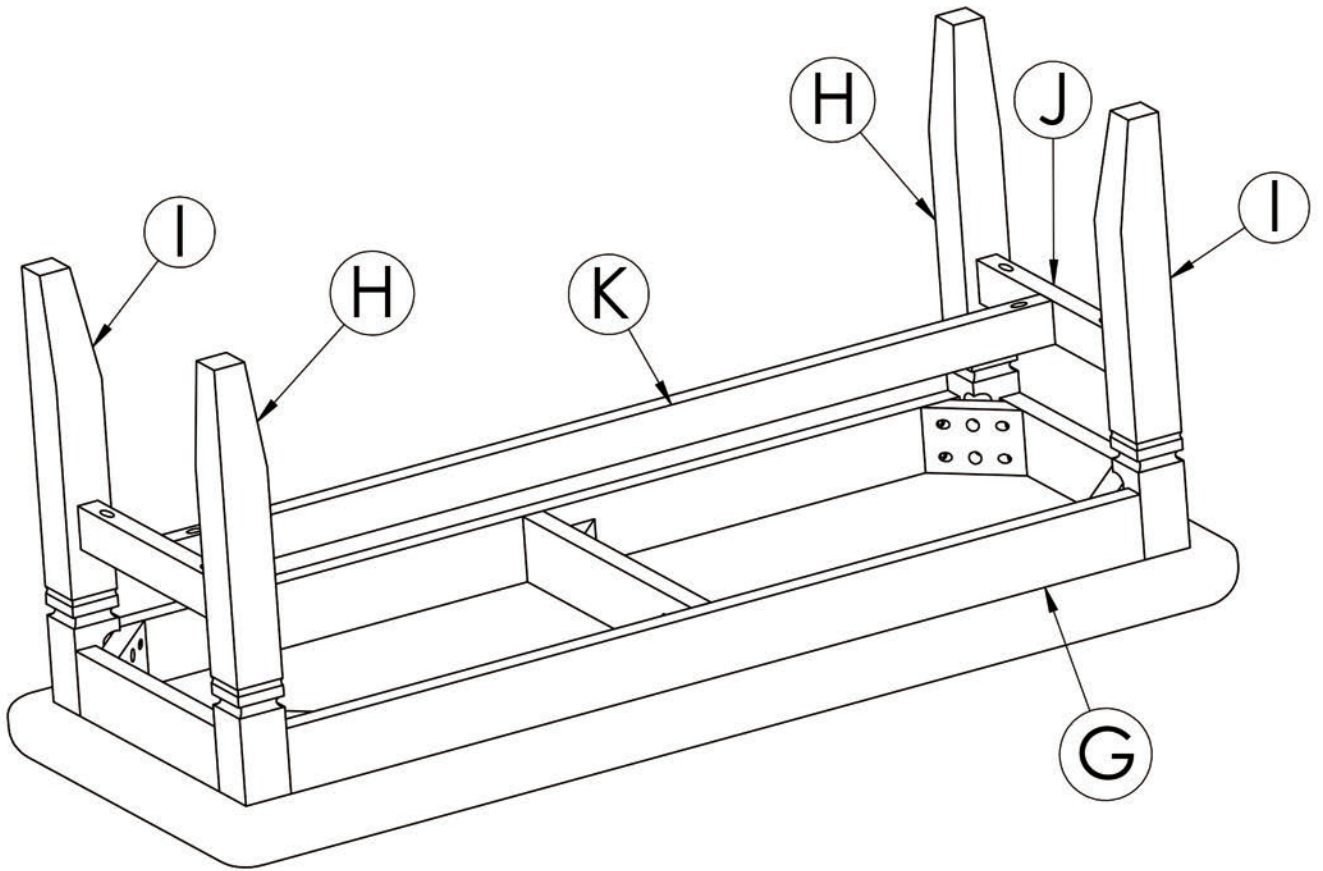

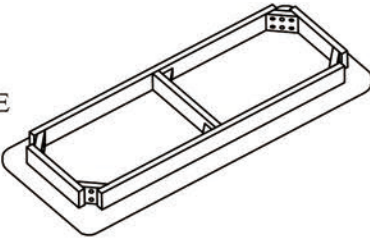

IMPORTANT NOTE :

- ① PLACE ALL PARTS ON A CLEAN AND SMOOTH SURFACE SUCH AS A RUG OR CAPET TO AVOID THE PARTS FORM BEING SCARTCHED .
- ② BEFORE YOU BEGIN , KINDLY FOLLOW THE ASSEMBLY INSTRUCTIONS STEP BY STEP
- ③ DO NOT TIGHTEN ALL SCREWS AND BOLTS UNTILL THE BENCH FULLY SET-UP

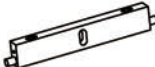

Part List

Hardware List

NO.	Part Description	Q'ty	NO.	Hardware Description	Q'ty
G	 TOP FRAME	1pc	1	Bolt 1/4 * 50 mm 	8pcs
			2	Spring Washer 1/4 * 11mm * 1.5 mm 	8pcs
H	 LEGS 1	2pcs	3	Flat Washer 1/4 * 16mm * 1.5 mm 	8pcs
I	 LEGS 2	2pcs	4	Screwa 4mm * 38 mm 	6pcs
J	 SIDE STRETCHER	2pcs	5	Allen Key 4mm * 60 mm 	1pc
K	 HORIZONTAL STRETCHER	1pc			

ASSEMBLY TOOLS REQUIRED (NOT INCLUDED)



STEP 1

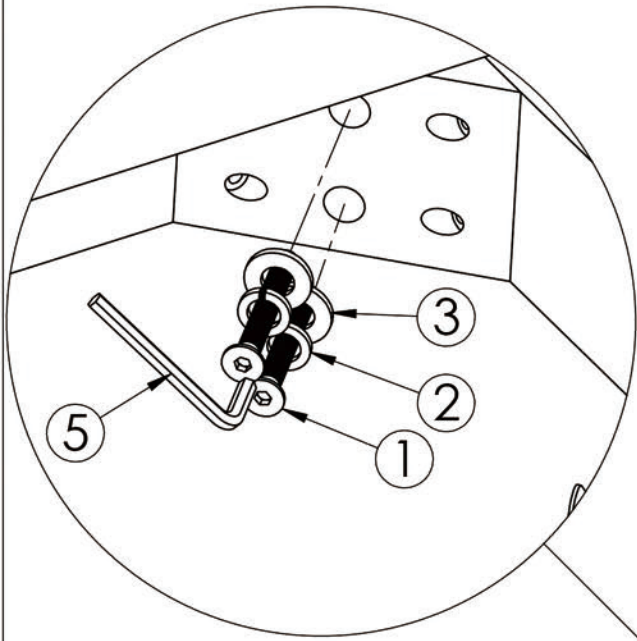

STEP 2

